

RoHS  
Compliant

## Specification

General tolerances : ±0.2mm

## Diagram

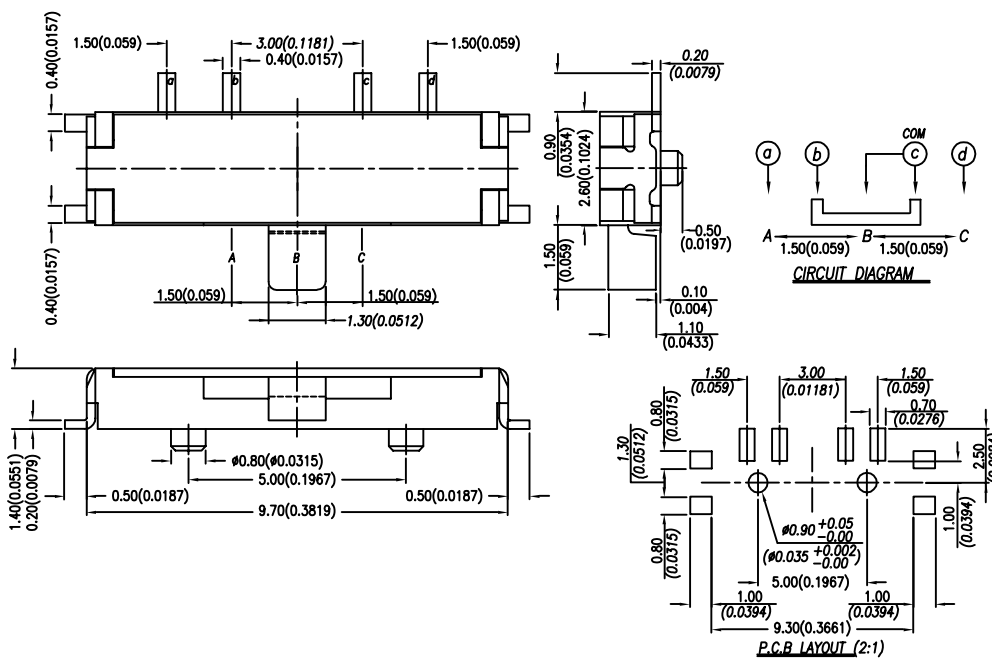

Dimensions : Millimetres (Inches)

Item	Description	Q'ty	Materials	Treatment
1	Cover	1	Nickel Silver	--
2	Stem		High-Temp Thermoplastic Nylon L 94V - 0	Molded Black
3	Contact		Alloy Copper	Gold Plated
4	Spring Plate		Stainless Steel	--
5	Base		High-Temp Thermoplastic LCP	Molded Black
6	Terminal		Brass	Gold Plated

# Tactile Switch

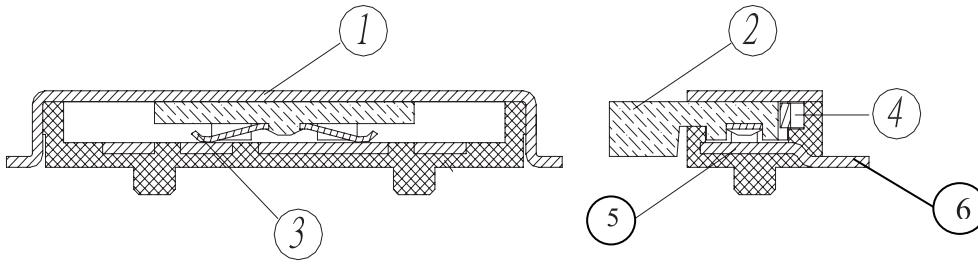

## 1. Style

This specification describes “DUAL IN-LINE PACKAGE SWITCHES” mainly used as signal switch of electric devices with the general requirements of mechanical and electrical characteristics.

1.1 Operating Temperature Range: -20°C+70°C

1.2 Storage Temperature Range : -40°C+85°C

1.3 The shelf life of product is within 6 months.

## 2. Current Range:

2.1 Non-Switching : 300mA, 4V DC

2.2 Switching : 25mA , 24V DC

3. **Type of Actuation:** Actuated by sliding

## 4. Test Sequence:

Item	Description	Test Conditions	Requirements
<b>Electric Performance</b>			
1	Visual Examination	By visual examination check without any out pressure & testing.	There shall be no defects that affect the serviceability of the product.
2	Contact Resistance	1. To be measured between the two terminals associated with each switch pole. 2. Measurements shall be made with a 1kHz shall current contact resistance meter.	The first contact resistance is max 70mΩ.
3	Insulation Resistance	100V DC, 1 minute ± 5 sec.	100MΩ Min.
4	Dielectric Withstanding Voltage	100V AC (50Hz or 60 Hz) shall be applied between all the adjacent terminals and between the terminal and the frame for 1 minute.	There shall be no breakdown or flashover
5	Capacitance	1 MHz ±10 kHz	5 pF max.
<b>Mechanical Performance</b>			
6	Operation Force	Applied in the direction of operation. 	A→B 150±100gf(1.47N±0.98N)
			B→C 200±150gf(1.96N±1.47N)
			C→B 150±100gf(1.47N±0.98N)
			B→A 200±150gf(1.96N±1.47N)

# Tactile Switch

7	Stop Strength	1. Operating direction: 1kgf static loading on the actuator for 15 sec. 2. Non-operating direction: 0.3kgf static loading on the actuator for 15 sec.	There shall be no sign of electrical function out of order or damage.
8	Soldering Heat Resistance	Soldering Temperature : TEMP            TIME 260°C±5°C    3±1 sec. 2.Duration of Solder Immersion: 5±1 sec. 3.Frequency of Soldering Process: 2 times max. (PCB is 1.6mm in thickness.)	As shown in item 2~6 Specification Requirements after test. (The max. temperature of IR reflow is 260°C, referred to the temperature profile.)
9	Vibration	Shall be vibrated in accordance with Method 201A of MIL-STD-202F 1. Frequency: 10-55-10 Hz 1 min/cycle. 2. Direction: 3 vertical directions including the direction of operation. 3. Test Time: 2 hours each direction.	As shown in item 2~6
10	Shock	Shall be shocked in accordance with Method 213B condition A of MIL-STD-202F 1) Acceleration: 50G 2) Action time:11±1m seconds 3) Testing Direction: 6 sides 4) Test Cycle: 3 times in each direction	As shown in item 2~6
11	Solderability	1. MPMSS4-V-T/R Soldering Temperature: 245±3°C Lead-Free solder: M705E JIS Z 3282 Class A (Tin 96.5%, Silver 3%, Copper 0.5%) 2. Flux: 5-10 seconds. 3. Duration of solder Immersion: 5±1 sec.	No anti-soldering and the coverage of dipping into solder must more than 75% was requested.
<b>Durability</b>			
12	Operating Life	Measurements shall be made following the test forth below: 1. 25 mA, 24V DC resistive load 2. Rate of Operation: 15~20 cycles/ minute 3. Cycle of Operation: 10000 cycles.	1. As shown in item 3,4 2. Contact Resistance: 130mΩ max. (final-after test) 3. The operation force after life test should be within ±30% of the specs.
<b>Weather-Proof</b>			
13	Resistance Low Temperature	Following the test set forth below the sample shall be left in normal temperature and humidity conditions for an hour before the measurements are made: 1)Temperature: -40±3°C 2)Time: 96 hours	As shown in item 2~6
14	Resistance High Temperature	Following the test set forth below the sample shall be left in normal temperature and humidity conditions for an hour before the measurements are made: 1. Temperature:85±2°C 2. Time:96 hours	1.As shown in item 3~6 2.Contact Resistance: 100mΩ max.

15	Resistance Humidity	Following the test set forth below the sample shall be left in normal temperature and humidity conditions for an hour before the measurements are made: 1. Temperature:40±2°C 2. Relative Humidity:90~95% 3. Time:96 hours	1. As shown in item 4~6 2. Contact Resistance: 100mΩ Max 3. Insulation Resistance: 10MΩ Min
----	------------------------	---	---

## Soldering Conditions

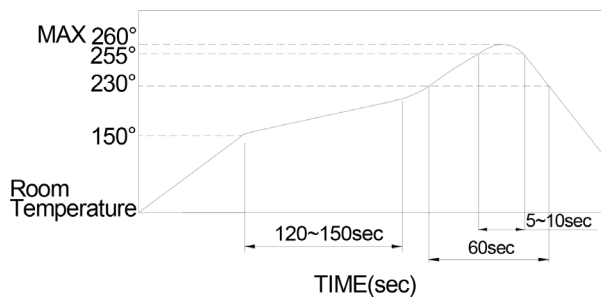

- The condition mentioned above is the temperature on the Cu foil of the PCB surface. There are cases where board's temperature greatly differs from switch's surface temperature depending on board's material, size, thickness, etc. Care, therefore, should be used not to allow switch's surface temperature to exceed 260°C.
- Manual Soldering
 

Soldering Temperature	Max.350°C
Continuous Soldering Time	Max. 5 seconds

## Part Number Table

Description	Part Number
Slide Switch, 1P3T, SMT	MPMSS4-V-T/R

**Important Notice :** This data sheet and its contents (the "Information") belong to the members of the AVNET group of companies (the "Group") or are licensed to it. No licence is granted for the use of it other than for information purposes in connection with the products to which it relates. No licence of any intellectual property rights is granted. The Information is subject to change without notice and replaces all data sheets previously supplied. The Information supplied is believed to be accurate but the Group assumes no responsibility for its accuracy or completeness, any error in or omission from it or for any use made of it. Users of this data sheet should check for themselves the Information and the suitability of the products for their purpose and not make any assumptions based on information included or omitted. Liability for loss or damage resulting from any reliance on the Information or use of it (including liability resulting from negligence or where the Group was aware of the possibility of such loss or damage arising) is excluded. This will not operate to limit or restrict the Group's liability for death or personal injury resulting from its negligence. Multicomp Pro is the registered trademark of Premier Farnell Limited 2019.