

San Ace 40L 9LG type

Long Life Fan

Features

High Static Pressure, High Airflow, and Long Life

This fan delivers a maximum static pressure of 1780 Pa and a maximum airflow of 0.93 m³/min.⁽¹⁾ Compared with our current model,⁽²⁾ the maximum static pressure has increased by 8.6 times and maximum airflow has increased by 1.8 times. This fan offers greatly improved static pressure and airflow while maintaining the long service life of the current model.

Low Noise and Energy Saving

The PWM control enables the control of fan speed, contributing to lowering noise and improving energy efficiency of devices.

(1) For models 9LG0412P3G001 and 9LG0424P3G001.

(2) Current model: 40 x 40 x 28 mm San Ace 40L 9L type Long Life Fan (model: 9L0412J301).



40 x 40 x 28 mm

Specifications

The models listed below **have a pulse sensor with PWM control.**

Model no.	Rated voltage [V]	Operating voltage range [V]	PWM duty cycle* [%]	Rated current [A]	Rated input [W]	Rated speed [min ⁻¹]	Max. airflow [m ³ /min] [CFM]	Max. static pressure [Pa] [inchH ₂ O]	SPL [dB(A)]	Operating temperature [°C]	Expected life [h]
9LG0412P3G001	12	10.2 to 13.8	100	1.9	22.8	33500	0.93 32.9	1780 7.15	68	-20 to +70	80000/60°C (115000/40°C)
			20	0.09	1.08	7500	0.2 7.07	89 0.36	33		
9LG0412P3S001			100	1.23	14.8	28000	0.77 27.2	1290 5.18	65		
			20	0.07	0.84	5700	0.15 5.3	53 0.21	28		
9LG0412P3H001			100	0.69	8.28	22500	0.62 21.9	830 3.33	62		
			20	0.07	0.84	5700	0.15 5.3	53 0.21	28		
9LG0424P3G001	24	21.6 to 26.4	100	0.95	22.8	33500	0.93 32.9	1780 7.15	68	-20 to +70	80000/60°C (115000/40°C)
			20	0.07	1.68	6800	0.18 6.36	73 0.29	32		
9LG0424P3S001			100	0.61	14.6	28000	0.77 27.2	1290 5.18	65		
			20	0.05	1.2	5000	0.13 4.59	41 0.16	27		
9LG0424P3H001			100	0.34	8.16	22500	0.62 21.9	830 3.33	62		
			20	0.05	1.2	5000	0.13 4.59	41 0.16	27		

* PWM frequency is 25 kHz. Models without ratings for 0% PWM duty cycle have zero speed at 0%. When control terminal is open, speed is the same as at 100% duty cycle.

Models with the following sensor specifications are also available as options: **Without sensor** **Lock sensor**

Common Specifications

- Material Frame: Aluminum (Black coating), Impeller: Plastic (Flammability: UL 94V-0)
- Expected life Refer to specifications
(L10 life: 90% survival rate for continuous operation in free air at 60°C, rated voltage)
Expected life at 40°C is for reference only.
- Motor protection function Locked rotor burnout protection, Reverse polarity protection
- Dielectric strength 50/60 Hz, 500 VAC, for 1 minute (between lead wire conductors and frame)
- Insulation resistance 10 MΩ min. at 500 VDC (between lead wire conductors and frame)
- Sound pressure level (SPL) A-weighted sound pressure level (SPL) at 1 m away from the air inlet.
- Operating temperature Refer to specifications (Non-condensing)
- Storage temperature -30 to +70°C (Non-condensing)
- Lead wire ⊕ Red ⊖ Black **Sensor** Yellow **Control** Brown
- Mass 60 g

Airflow - Static Pressure Characteristics

PWM duty cycle

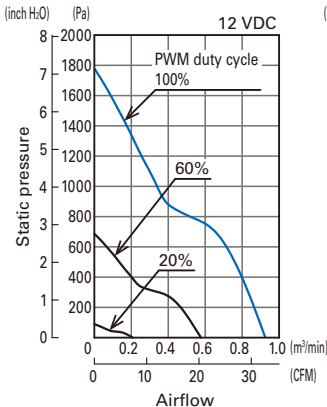

9LG0412P3G001

Operating voltage range

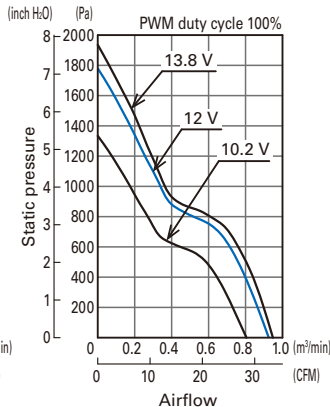

9LG0412P3G001

PWM duty cycle

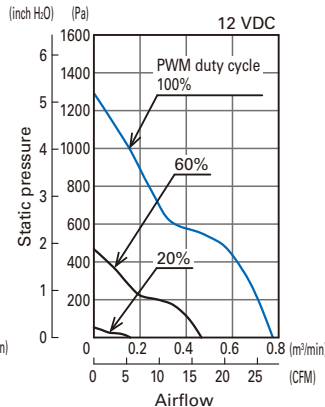

9LG0412P3S001

Operating voltage range

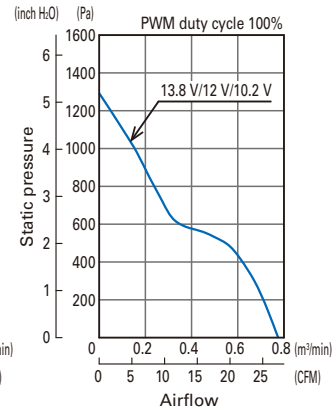

9LG0412P3S001

PWM duty cycle

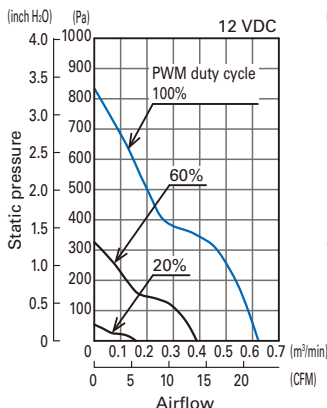

9LG0412P3H001

Operating voltage range

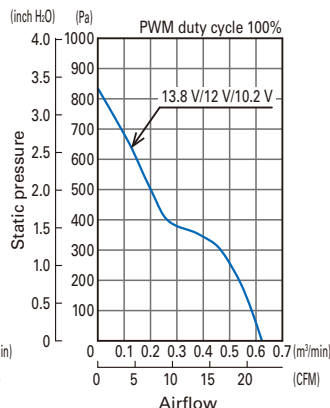

9LG0412P3H001

PWM duty cycle

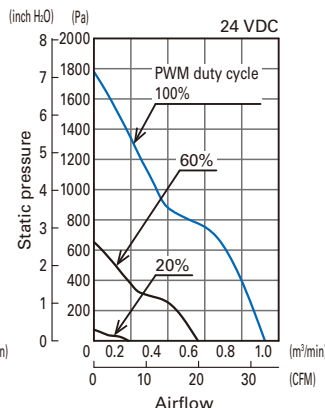

9LG0424P3G001

Operating voltage range

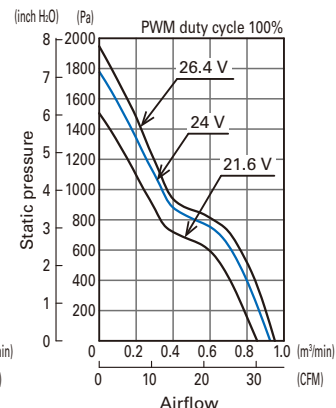

9LG0424P3G001

PWM duty cycle

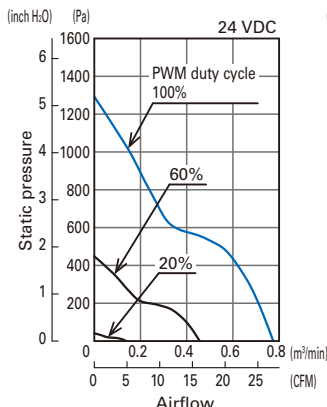

9LG0424P3S001

Operating voltage range

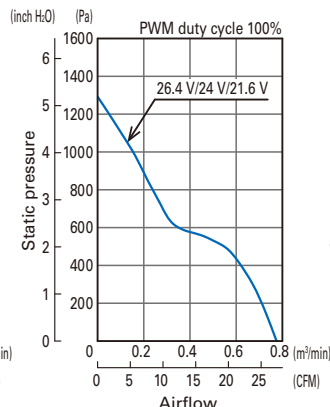

9LG0424P3S001

PWM duty cycle

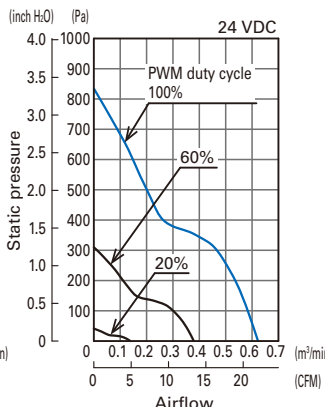

9LG0424P3H001

Operating voltage range

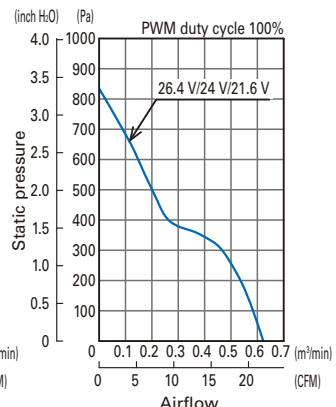

9LG0424P3H001

PWM Duty - Speed Characteristics Example

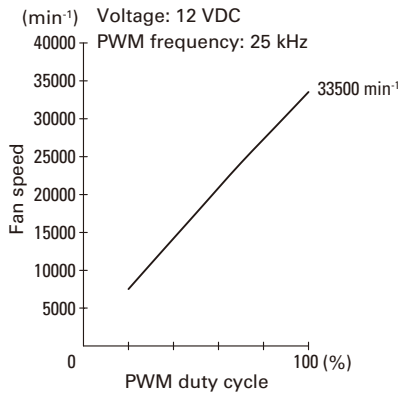

9LG0412P3G001

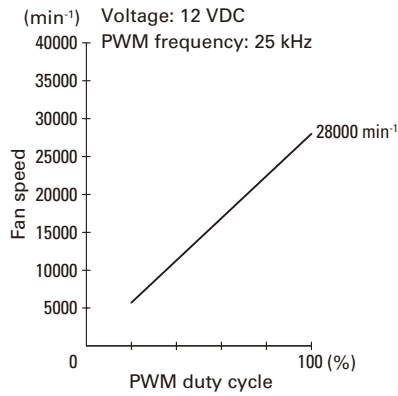

9LG0412P3S001

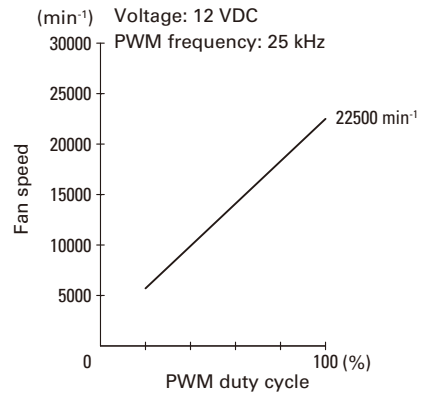

9LG0412P3H001

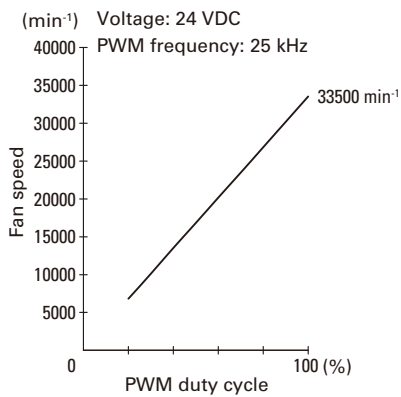

9LG0424P3G001

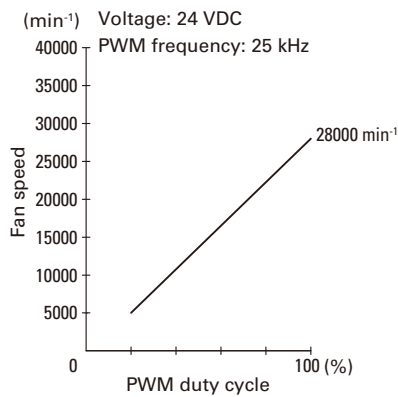

9LG0424P3S001

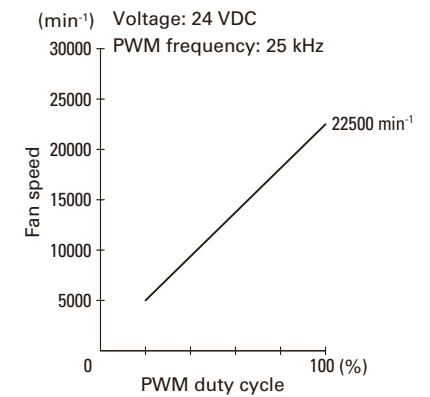

9LG0424P3H001

PWM Input Signal Example

Input signal waveform

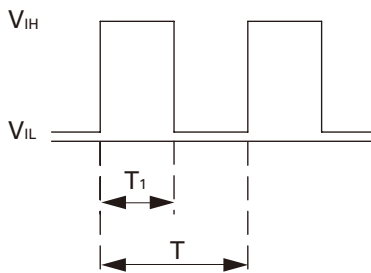

$V_{IH} = 4.75 \text{ to } 5.25 \text{ V}$ $V_{IL} = 0 \text{ to } 0.4 \text{ V}$

PWM duty cycle (%) = $\frac{T_1}{T} \times 100$ PWM frequency 25 (kHz) = $\frac{1}{T}$

Current source (I_{source}) = 1.0 mA max. (when control voltage is 0 V)

Current sink (I_{sink}) = 1.0 mA max. (when control voltage is 5.25 V)

Control terminal voltage = 5.25 V max. (when control terminal is open)

When the PWM control terminal is open,

the fan speed is the same as the speed at 100% PWM duty cycle.

Either a TTL input or open collector/drain input can be used for the PWM input signal.

Example of Connection Schematic

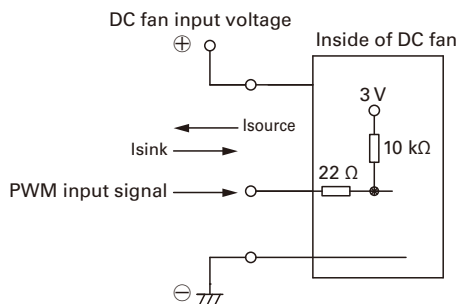

Specifications for Pulse Sensors

Output circuit: Open collector

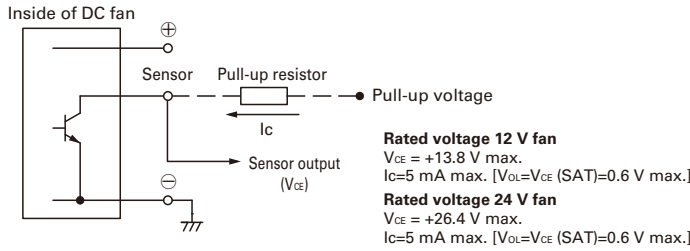

Output waveform (Need pull-up resistor)

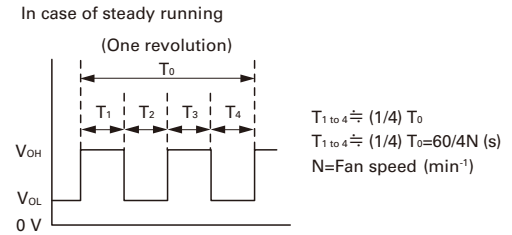

Dimensions (unit: mm)

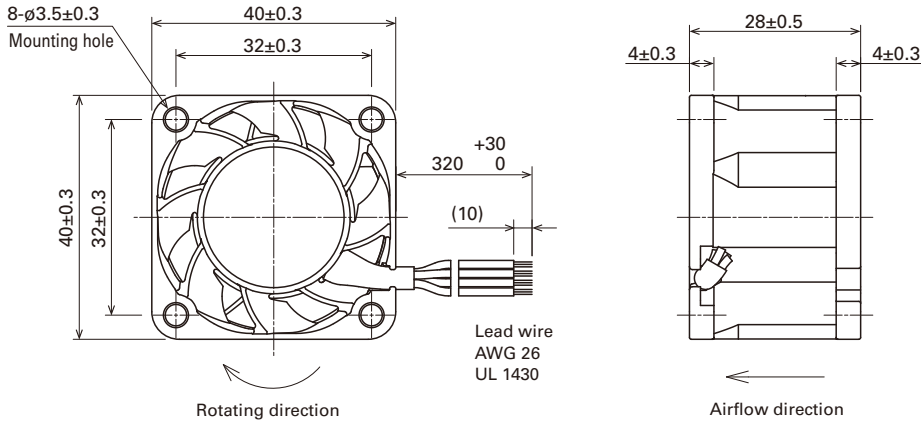

Reference Dimensions of Mounting Holes and Vent Opening (unit: mm)

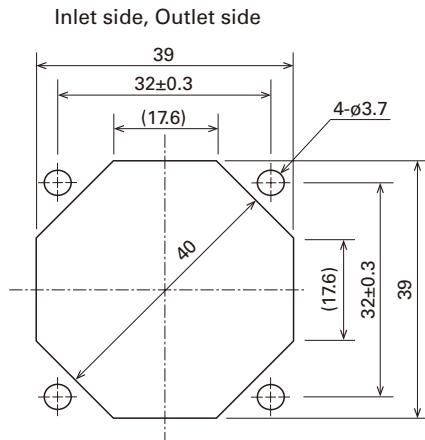

Options

Finger guards

Model no.: 109-059, 109-059H

Notice

- Please read the "Safety Precautions" on our website before using the product.
- The products shown in this catalog are subject to Japanese Export Control Law. Diversion contrary to the law of exporting country is prohibited.
- For protecting fan bearings against electrolytic corrosion near strong electromagnetic noise sources, we provide effective countermeasures such as Electrolytic Corrosion Proof Fans and EMC guards. Contact us for details.

SANYO DENKI CO., LTD. 3-33-1 Minami-Otsuka, Toshima-ku, Tokyo 170-8451, Japan TEL: +81 3 5927 1020

<https://www.sanyodenki.com/>

The names of companies and/or their products specified in this document are the trade names, and/or trademarks and/or registered trademarks of such respective companies. San Ace, SANUPS, and SANMOTION are registered trademarks of SANYO DENKI CO., LTD.

Specifications are subject to change without notice.

CATALOG No. C1139B001 '23.5