

THIS IS ISSUED IN STRICT CONFIDENCE THAT IT IS NOT USED AS A BASIS FOR MANUFACTURE OR SALE AND THAT IT IS NOT COPIED, REPRINTED OR DISCLOSED TO A THIRD PARTY EITHER WHOLLY OR IN PART WITHOUT THE PRIOR WRITTEN CONSENT OF CAL TEST ELECTRONICS, INC.

REVISIONS			
REV.	DESCRIPTION	DATE	APPROVED
A	CLASS A RELEASED	10/19/2023	B. HANSEN

NOTES:

- ALL SPECIFICATIONS SUBJECT TO CHANGE WITHOUT NOTICE.
- MATERIAL:
 - BNC MALE CONNECTOR -
 - BODY & COUPLING NUT: BRASS, NICKEL PLATED.
 - DIELECTIC: PTFE
 - CENTER CONTACT: BRASS, GOLD PLATED.
 - MOLDED BOOT: PVC, BLACK.
 - RG58C/U COAX CABLE -
 - JACKET: PVC, BLACK; ϕ 4.95 O.D.
 - DIELECTIC: PE
 - CENTER CONDUCTOR: 22 AWG (19X34) TINNED COPPER, STRANDED.
 - BREAKOUT: PVC, BLACK
 - 4mm STACKING BANANA PLUGS -
 - BODY: BRASS, NICKEL PLATED.
 - INSULATOR (BODY): PP, COLOR SAME AS WIRE.
 - CONTACT: BECU, NICKEL PLATED
- ELECTRICAL:
 - IMPEDANCE:
 - ASSEMBLY: NON-CONSTANT
 - BNC & RG58C/U: 50 Ω
 - VOLTAGE -
 - 30 VRMS / 60 VDC (HANDHELD)
 - 500 VRMS (HANDS FREE)
 - DO NOT USE ON CIRCUITS SUBJECT TO TRANSIENT OVERVOLTAGES.
 - CURRENT: 3 A MAX.
- MECHANICAL:
 - OPERATING TEMPERATURE: 0°C TO +50°C
 - CABLE BEND RADIUS:
 - REPEATED MIN. - 49.8 mm
 - ONE-TIME MIN. - 25 mm
- CE MARK:
 - ROHS 2 COMPLIANT.
 - UKCA COMPLIANT.

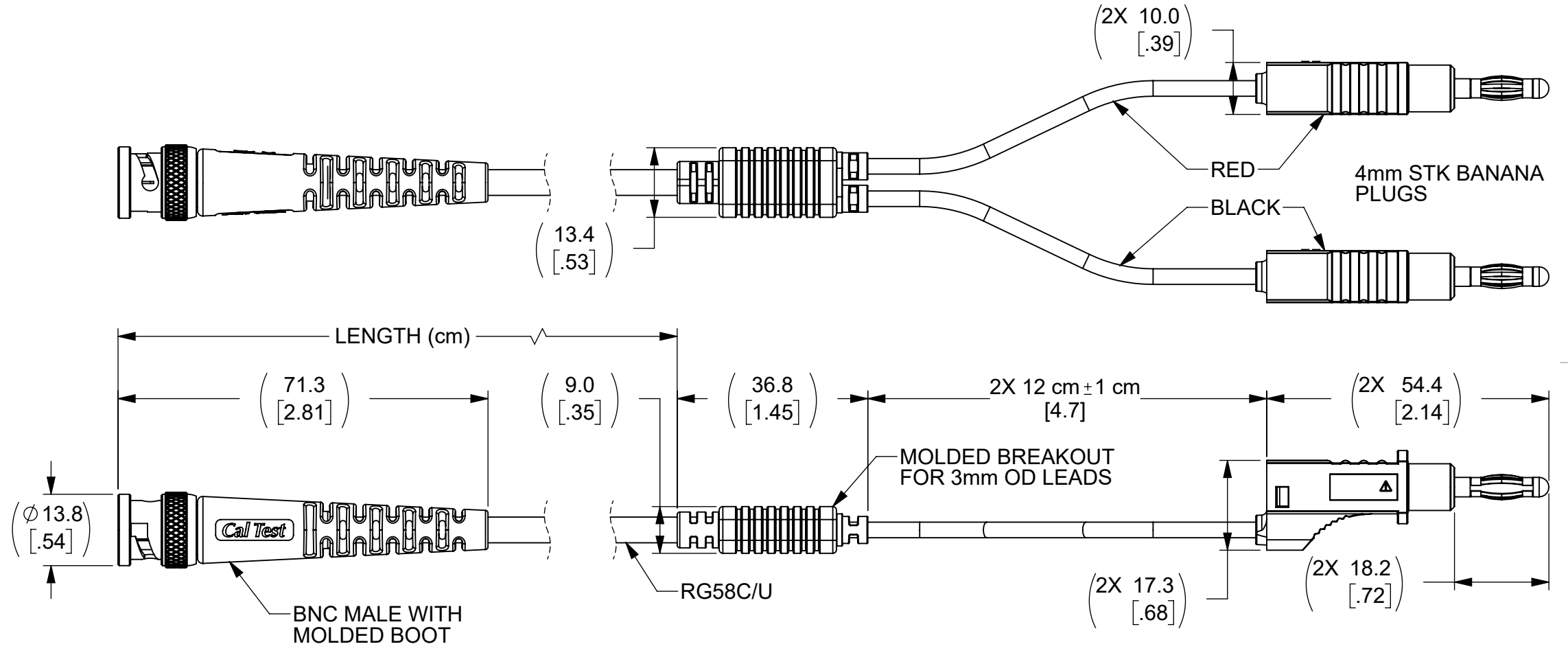
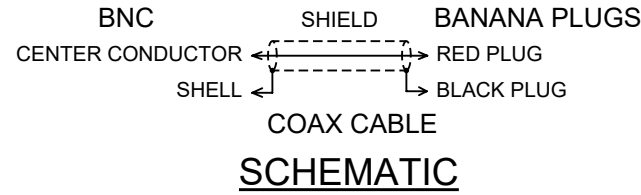

CT4452-100	100 ±1.5	-100
MODEL NUMBER	LENGTH & TOLERANCE (cm)	MODEL NUMBER -XXX EXTENSION

MODEL NUMBER TABLE			
THIRD ANGLE PROJECTION	UNLESS OTHERWISE SPECIFIED DIMENSIONS ARE IN MILLIMETERS TOLERANCES ARE: X.X = ±0.5 X.X* = ±0.5* X.XX = ±0.25 X.XXX = ±0.125 DO NOT SCALE DRAWING	PROJECT NO. A660(b)	METRIC 22820 Savi Ranch Prky. Yorba Linda, CA 92887 USA
	MATERIAL SEE NOTES	APPROVALS	TITLE CABLE ASSEMBLY, BNC MALE TO 4mm STK BANANA PLUG BREAKOUTS, RG58C/U
REFERENCE	TREATMENT NONE	DATE 10/17/2023	SIZE B
	FINISH SEE NOTES	ENGR. B. Hansen	CAGE CODE 43F45
		DESIGN ACTIVITY	SCALE 1:1
			DWG. NO. CT4452
			REV. A
			SHEET 1 OF 1

4

3

2

1

D

D

C

C

B

B

A

A

4

3

2

1