

Stainless Steel Low Profile Vandal Resistant - Latching

FRONT PANEL MOUNTING



MPL031
Sealed to IP66

- Front Panel Sealed to IP66
- 21.5mm diameter
- 2A, 50V a.c./d.c.
- Single pole push to make
- Latching switch

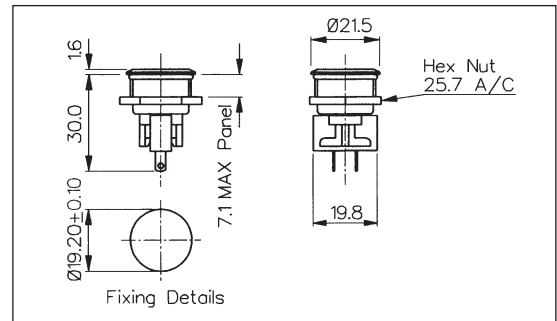

REAR PANEL MOUNTING

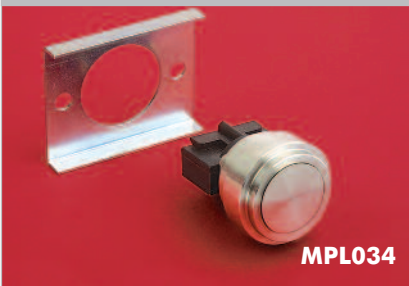

MPL034

- Rear Panel Mounting
- Flush with Panel
- 19mm diameter
- 2A, 50V
- Single pole push to make
- Latching switch

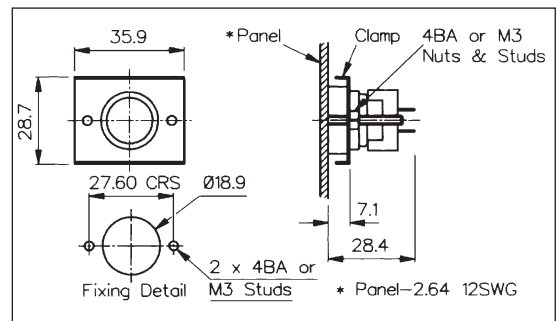

Specification	MPL031	MPL034
Terminations:	Solder Tags	Solder Tags
Switching:	S.P.M.B. - Latching	S.P.M.B. - Latching
Max. Rating:	2A, 50V a.c./d.c.	2A, 50V
Contact Resistance:	<10mΩ	<10mΩ
Insulation Resistance:	>10 ³ MΩ	>10 ³ MΩ
Dielectric Strength:	>2.0kV a.c.	>2.0kV a.c.
Operating Temp. Range:	-20°C to +70°C	-20°C to +70°C
Sealing (Front of panel only):	Protection Classification: IP66 EN60529 1992 (Switch not sealed)	
Operations		
Mechanical:	8,000 (min)	8,000 (min)
Electrical:	8,000 (min)	8,000 (min)
Operating Pressure:	5.5N (typ)	5.5N (typ)
Rear Nut Fixing Torque:	0.57Nm	-
Materials		
Mouldings:	Glass Filled Nylon	Glass Filled Nylon
Tags/Terminations:	Brass, Tin Plated	Brass, Tin Plated
Switch Body & Button:	Stainless Steel	Stainless Steel
Contacts:	Fine Silver	Fine Silver
Variants:	Engraved Button details on request	Engraved Button details on request
RoHS	Compliant	Compliant