

PRELIMINARY

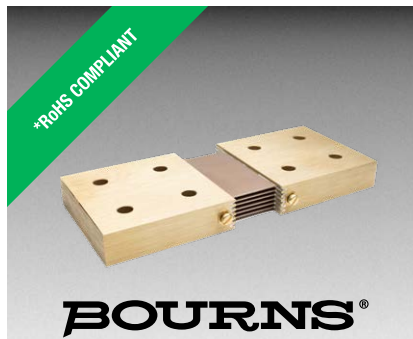

Features

- Formerly a Riedon™ product
- Current rating: 1500 to 6000 A
- Standard tolerance $\pm 0.25\%$
- 0.025 to 0.067 mΩ resistance
- Non-inductive metal element
- 50 mV & 100 mV Outputs
- RoHS compliant*

Applications

- Industrial power supplies
- UPS systems
- Inverters

RSJ Series – Riedon™ DC Ammeter Shunts / Busbar Shunts by Bourns

Electrical Characteristics

Model	Rated Current (A)	Operating Current (A)	Resistance (mΩ) ¹	
			50 mV Output	100 mV Output
RSJ-1500	1500	1000	0.033	0.067
RSJ-2000	2000	1333.3	0.025	0.05
RSJ-2500	2500	1667	0.020	0.040
RSJ-3000	3000	2000	0.016	0.33
RSJ-4000	4000	2667	0.012	0.025
RSJ-5000	5000	3333	0.010	0.020
RSJ-6000	6000	4000	0.0083	0.016

¹ Please contact Bourns for additional options.

TCR Curve

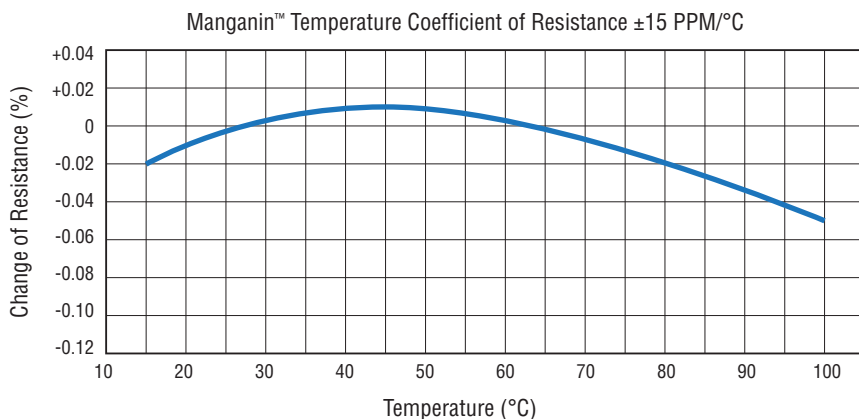

Note: Applies to resistance element only

Typical Part Marking

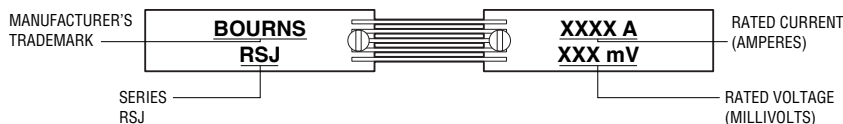

Additional Information

Click these links for more information:



General Specifications

Rated Output 50 mV, 100 mV, Custom
 Voltage Tolerance $\pm 0.25\%$ Standard
 Operating Temperature
 -40 °C to +100 °C
 Storage Temperature
 -55 °C to +125 °C
 Maximum Blade Temperature +145 °C

Materials

Construction Flame resistant all-metal
 Resistance Element Manganin
 Terminal Block Brass

How to Order

RSJ - 1500 - 50

Model _____
 Rated Current (see table) _____
 Voltage Output (mV) _____
 50 = 50 mV
 100 = 100 mV

Operating Current Derating

For continuous operation, it is recommended that shunts are not operated at more than two thirds (2/3) the rated current under normal conditions per IEEE standards for DC instrument shunts. At ambient temperatures above 40 °C, the current must be further derated to prevent damage.

Packaging Specifications

Bulk, packaged in cellulose paper.



WARNING Cancer and Reproductive Harm
www.P65Warnings.ca.gov

*RoHS Directive 2015/863, Mar 31, 2015 and Annex.

Specifications are subject to change without notice. Users should verify actual device performance in their specific applications. The products described herein and this document are subject to specific legal disclaimers as set forth on the last page of this document, and at www.bourns.com/docs/legal/disclaimer.pdf.

“Bourns” is a registered trademark of Bourns, Inc. in the United States and other countries.

In April 2023, BE Services Company, Inc., a subsidiary of Bourns, Inc., purchased certain assets of Riedon, Inc., including its logo and trademarks and the right to continue to manufacture former Riedon™ products.

“Riedon Logo” is a registered trademark of BE Services Company, Inc., in the United States.

“Riedon” is a trademark of BE Services Company, Inc.

“Manganin” is a trademark of Isabellenhütte Heusler GmbH & Co.

RSJ Series – Riedon™ DC Ammeter Shunts / Busbar Shunts by Bourns



Product Dimensions

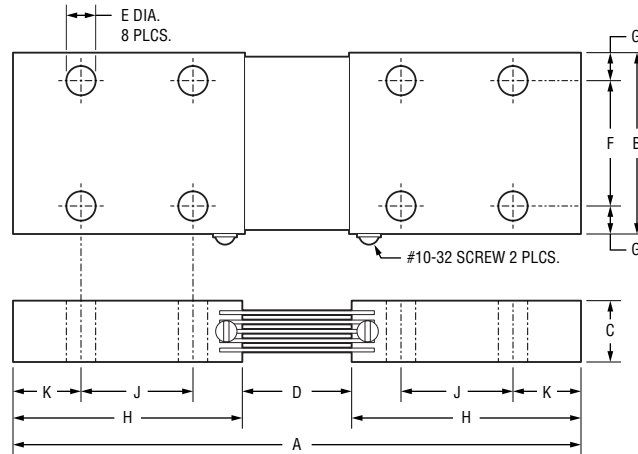

50 mV Output Models

Model	A	B	C	D	E	F	G	H	J	K
RSJ-1500-50	244.3 (9.62)	76.2 (3.0)	25.4 (1.0)	92 (3.62)	11 (.434)	50.8 (2.0)	12.7 (0.5)	101.6 (4.00)	50.8 (2.0)	25.4 (1.0)
RSJ-2000-50		101.6 (4.0)	31.8 (1.25)		14.3 (.563)		63.5 (2.5)			
RSJ-2500-50						127 (5.0)				
RSJ-3000-50		38.1 (1.5)	63.5 (2.5)		31.8 (1.25)					
RSJ-4000-50						50.8 (2.0)				
RSJ-5000-50		50.8 (2.0)								
RSJ-6000-50										

DIMENSIONS: $\frac{\text{MM}}{\text{(INCHES)}}$

Dimension tolerances: ± 0.381 mm (± 0.015 in.) for hole diameters.
All other dimensions have a ± 0.762 mm (± 0.030 in.) tolerance.

Specifications are subject to change without notice.

Users should verify actual device performance in their specific applications.

The products described herein and this document are subject to specific legal disclaimers as set forth on the last page of this document, and at www.bourns.com/docs/legal/disclaimer.pdf.

RSJ Series – Riedon™ DC Ammeter Shunts / Busbar Shunts by Bourns

BOURNS®

Product Dimensions (continued)

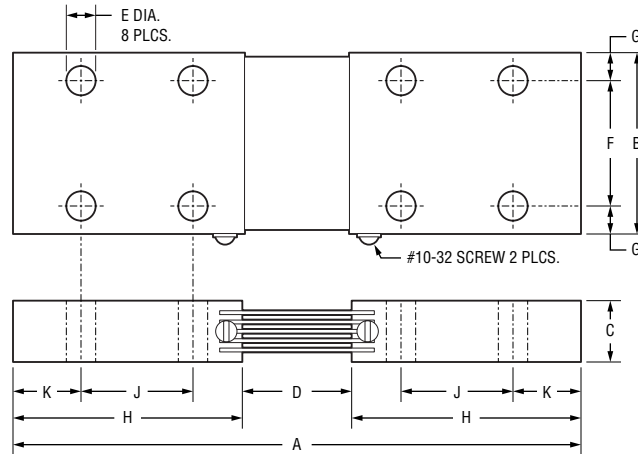

100 mV Output Models

Model	A	B	C	D	E	F	G	H	J	K
RSJ-1500-100	286 (11.25)	76.2 (3.0)	25.4 (1.0)	133.4 (5.25)	11 (.434)	50.8 (2.0)	12.7 (0.5)	101.6 (4.00)	50.8 (2.0)	25.4 (1.0)
RSJ-2000-100		101.6 (4.0)	31.8 (1.25)		14.3 (.563)		63.5 (2.5)			
RSJ-2500-100						127 (5.0)				
RSJ-3000-100		38.1 (1.5)	63.5 (2.5)		31.8 (1.25)					
RSJ-4000-100						50.8 (2.0)				
RSJ-5000-100		50.8 (2.0)								
RSJ-6000-100										

DIMENSIONS: $\frac{\text{MM}}{\text{(INCHES)}}$

Dimension tolerances: ± 0.381 mm (± 0.015 in.) for hole diameters.
All other dimensions have a ± 0.762 mm (± 0.030 in.) tolerance.

Specifications are subject to change without notice.

Users should verify actual device performance in their specific applications.

The products described herein and this document are subject to specific legal disclaimers as set forth on the last page of this document, and at www.bourns.com/docs/legal/disclaimer.pdf.

Technical Notes

Mounting: Shunts should be mounted with manganin resistive blades in a vertical position in order to promote the free convective flow of air. If vertical mounting is not practical, forced air cooling or adding heat sinks to the blocks can reduce the operating temperature. The manganin blades must never exceed +140 °C, otherwise permanent resistance change may occur.

When current of 100 A or greater is passing through the shunt, the major portion of heat generated is dissipated by conduction through the shunt terminal blocks into the connecting busbar or cable. Therefore, it is necessary to ensure that good contact is made between the shunt terminal blocks and the conductor terminals and that the conductors have adequate cross section to keep the temperature of the shunt from exceeding 140 °C (125 °C recommended).

If the shunt is mounted in an enclosure, care must be taken to ensure adequate cooling. If the power density is greater than 1/4 watt per square inch of the enclosure surface for all enclosed devices, additional cooling must be supplied in the form of air vents or fans.

Shunts also must be installed in a way that protects them from thermal expansion forces produced from busbar or short-circuit forces. Flexible wiring may be required in high pulse current, high vibration, or high temperature applications.

Where possible, all shunts should be mounted on the ground side of the circuit. For circuits above 750 VDC, RS shunts **must** be mounted on the ground side due to the dielectric strength of the shunt base.

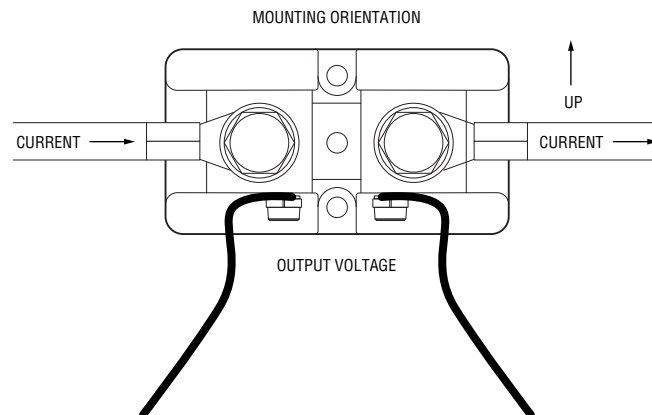

Operating Current Derating: For continuous operation, it is recommended that shunts are not operated at more than two thirds (2/3) the rated current under normal conditions per IEEE standards for DC instrument shunts. At ambient temperatures above 40 °C, the current must be further derated to prevent damage.

Pulse Operation: Shunts that do not need continuous operation and are only exposed to intermittent pulses can be operated at levels above their rated current for short periods of times. Pulses are limited to the maximum temperature of the blades not exceeding 140 °C (125 °C recommended). Many variables such as ambient temperature, cross section of the current carrying conductors, and pulse duration make calculating exact values difficult. Shunt size will need to be validated by customer for pulse current and duty cycle on a case-by-case basis.

BOURNS®

Americas: Tel: +1 951-781-5500 • Email: americus@bourns.com

Mexico: Tel: +52-614-478-0400 • Email: mexicus@bourns.com

Asia: Tel: +886-2-2562-4117 • Email: asiacus@bourns.com

EMEA: Tel: +36 88 885 877 • Email: eurocus@bourns.com

www.bourns.com

REV. 07/24

Specifications are subject to change without notice.

Users should verify actual device performance in their specific applications.

The products described herein and this document are subject to specific legal disclaimers as set forth on the last page of this document, and at www.bourns.com/docs/legal/disclaimer.pdf.

Shunt FAQs

Question: What is a shunt?

Answer: A shunt is simply a very precise resistor with its general operation adhering to Ohm's law.

Question: What is a Current Shunt Resistor?

Answer: Current shunt resistors are a low resistance precision resistor used to measure AC or DC electrical currents by the voltage drop those currents create across the resistance. These are also sometimes called ammeter shunts, which are a type of current sensor.

Question: What is the best way to mount a shunt?

Answer: Ideally, shunts should be mounted such that the resistive elements are oriented in a vertical plane to promote better cooling of the elements. This means that our shunts that include a base should be mounted to a panel or wall and not a floor or ceiling.

Question: What is the current lead time for your shunts?

Answer: Many of our shunts and fuse blocks are available from stock. If the device you are seeking is not in stock, our current manufacturing lead time for new orders is four to five weeks, often sooner.

Question: What is the accuracy of Bourns® shunts?

Answer: We offer a standard tolerance of $\pm 0.25\%$, however, we may be able to provide shunts with a tolerance as tight as $\pm 0.1\%$ on request.

Question: What voltage output options are offered for your shunts?

Answer: Our shunts are offered with either 50 mV or 100 mV outputs as standard. However, we can support nearly any voltage output on request including 60 mV and 75 mV.

Question: Are your shunts MIL spec?

Answer: The MK series of shunts are built to meet the standards of CID (commercial item description) A-A-55524, which superseded MIL STD 91586.

Question: What does rated current mean in regards to your shunts?

Answer: Our shunts are offered in many standard current ratings. This rating, often referred to as full scale, when applied to the shunt will result in the selected voltage output. For continuous use, we recommend that the shunt be operated at no more than 2/3 rated or full-scale current.

Question: Why do you recommend de-rating your shunts by rated or full-scale current?

Answer: We recommend not exceeding 2/3 rated or full-scale current in order to limit thermal heating of the resistive element.

Question: What is the power rating for your shunts?

Answer: The power rating of a shunt will always adhere to Ohm's law and may be calculated using the formula $P=I^2R$, where I is the rated current and V is the chosen milli-volt output of the shunt.

Question: Can shunts be used to measure short duration pulses?

Answer: Yes, a shunt can be used to measure pulses. There is an important thing to keep in mind, however. It is permissible to exceed the rated current of a shunt for a short period of time. The length of time will depend entirely on thermal concerns. It is important that the resistance element of the shunt not exceed 140 °C or the resistance value will forever be altered and the shunt ruined. In order to provide an additional safety factor, we recommend that the temperature of the resistance element not exceed 125 °C. Keep in mind that the voltage output of the shunt will be proportional to the input current, so it is necessary to ensure that the input of any monitoring equipment not be exceeded.

Question: Can shunts be used to measure AC currents as well as DC currents?

Answer: Bourns shunts may be used to measure low frequency AC currents. There is the possibility of electrical noise at higher frequencies, however, experience shows that the shunt will behave very well at frequencies up to about 1 kHz.

Question: I'd like to monitor a 500-watt source, will your shunts do this?

Answer: Probably! Remember that the shunt is not measuring the power of the source, only the current it provides to the load. Determine the expected current draw and then divide the expected current draw by 2/3 or 0.666 to determine the full scale or rated current you will need. You will also need to decide if you would prefer a 50 mV or 100 mV output.

Question: What is the operating temperature range of your shunts?

Answer: Our shunts will be most accurate when operated at temperatures between 30 °C and 60 °C. Below that temperature the shunt will not sustain any damage, but its accuracy will not be as precise. The absolute maximum temperature of the resistive element is 140 °C. Any temperature above that will permanently damage the shunt. We recommend not exceeding 125 °C to allow for a margin of safety.

Shunt FAQs (continued)**Question: Do you offer customization services for your shunts?**

Answer: Absolutely! We have helped design and have manufactured a number of application specific models for use in everything from electric vehicles to aerospace. We welcome both customer specific drawings as well as modifications to our standard shunts.

Question: What are the recommended wiring guidelines for your current sensing shunts?

Answer: Shunts should be wired into the circuit to be monitored in the ground or return line as close as practical to the power source. This will limit the voltage differential between the terminals of the shunt and ground, thus providing a degree of safety against electrical shock. In addition, placing the shunt near the power source will ensure that all of the loads are accounted for.

Question: Is ± 0.25 % the best tolerance you offer for your shunts?

Answer: ± 0.25 % is our standard tolerance, however, a large portion of our shunts are available with tolerances as tight as ± 0.1 %. Please send us an inquiry and we will confirm availability of the tighter tolerance.

Question: What is the TCR (temperature coefficient of resistance) of your shunts?

Answer: Our shunts utilize a manganin resistive element that features a very stable TCR of 15 ppm to 20 ppm in a temperature range of 30 °C to 60 °C.

Question: How do I help to limit the temperature rise of a shunt?

Answer: Above 100 amps, a vast majority of the heat generated by a shunt is dissipated into the current carrying bus bars or wires. In addition, it will help to mount the shunt in such a way that the resistive elements are vertical. Finally, it can be beneficial to have adequate air flow around the shunt to help remove excess heat.

Question: Do you offer crosses to Empro Shunts?

Answer: Yes, we have direct replacements for the following Empro series: HA, MLA, MLB, MLC, Type A, Type B, and Type E. We may be able to offer other alternatives of Empro Shunts as well, please send us an inquiry.

Question: Do you offer crosses to Canadian Shunts?

Answer: Yes, we have direct replacements for the following Canadian Shunt series: Type A, Type C, Type G, Type H, Type LA, Type LB, Type LC, and Type V. These Canadian Shunts can be customized to your specific needs to offer other alternatives as well, please send us an inquiry.

Question: What resistance material do you use for your shunts?

Answer: We utilize a material called Manganin. Manganin is a precision resistance alloy, with moderate resistivity, low temperature coefficient of resistance and low thermal EMF versus Copper. With high stability of electrical resistance, good working properties and very good weldability, Manganin is specially dedicated to precision resistors, electrical shunts which control and measure the current through devices such as electricity meters or DC ammeters.

This legal disclaimer applies to purchasers and users of Bourns® products manufactured by or on behalf of Bourns, Inc. and its affiliates (collectively, "Bourns").

Unless otherwise expressly indicated in writing, Bourns® products and data sheets relating thereto are subject to change without notice. Users should check for and obtain the latest relevant information and verify that such information is current and complete before placing orders for Bourns® products.

The characteristics and parameters of a Bourns® product set forth in its data sheet are based on laboratory conditions, and statements regarding the suitability of products for certain types of applications are based on Bourns' knowledge of typical requirements in generic applications. The characteristics and parameters of a Bourns® product in a user application may vary from the data sheet characteristics and parameters due to (i) the combination of the Bourns® product with other components in the user's application, or (ii) the environment of the user application itself. The characteristics and parameters of a Bourns® product also can and do vary in different applications and actual performance may vary over time. Users should always verify the actual performance of the Bourns® product in their specific devices and applications, and make their own independent judgments regarding the amount of additional test margin to design into their device or application to compensate for differences between laboratory and real world conditions.

Unless Bourns has explicitly designated an individual Bourns® product as meeting the requirements of a particular industry standard (e.g., IATF 16949) or a particular qualification (e.g., UL listed or recognized), Bourns is not responsible for any failure of an individual Bourns® product to meet the requirements of such industry standard or particular qualification. Users of Bourns® products are responsible for ensuring compliance with safety-related requirements and standards applicable to their devices or applications.

Bourns® products are not recommended, authorized or intended for use in nuclear, lifesaving, life-critical or life-sustaining applications, nor in any other applications where failure or malfunction may result in personal injury, death, or severe property or environmental damage. Unless expressly and specifically approved in writing by two authorized Bourns representatives on a case-by-case basis, use of any Bourns® products in such unauthorized applications might not be safe and thus is at the user's sole risk. Life-critical applications include devices identified by the U.S. Food and Drug Administration as Class III devices and generally equivalent classifications outside of the United States.

Bourns expressly identifies those Bourns® standard products that are suitable for use in automotive applications on such products' data sheets in the section entitled "Applications." Unless expressly and specifically approved in writing by two authorized Bourns representatives on a case-by-case basis, use of any other Bourns® standard products in an automotive application might not be safe and thus is not recommended, authorized or intended and is at the user's sole risk. If Bourns expressly identifies a sub-category of automotive application in the data sheet for its standard products (such as infotainment or lighting), such identification means that Bourns has reviewed its standard product and has determined that if such Bourns® standard product is considered for potential use in automotive applications, it should only be used in such sub-category of automotive applications. Any reference to Bourns® standard product in the data sheet as compliant with the AEC-Q standard or "automotive grade" does not by itself mean that Bourns has approved such product for use in an automotive application.

Bourns® standard products are not tested to comply with United States Federal Aviation Administration standards generally or any other generally equivalent governmental organization standard applicable to products designed or manufactured for use in aircraft or space applications. Bourns expressly identifies Bourns® standard products that are suitable for use in aircraft or space applications on such products' data sheets in the section entitled "Applications." Unless expressly and specifically approved in writing by two authorized Bourns representatives on a case-by-case basis, use of any other Bourns® standard product in an aircraft or space application might not be safe and thus is not recommended, authorized or intended and is at the user's sole risk.

The use and level of testing applicable to Bourns® custom products shall be negotiated on a case-by-case basis by Bourns and the user for which such Bourns® custom products are specially designed. Absent a written agreement between Bourns and the user regarding the use and level of such testing, the above provisions applicable to Bourns® standard products shall also apply to such Bourns® custom products.

Users shall not sell, transfer, export or re-export any Bourns® products or technology for use in activities which involve the design, development, production, use or stockpiling of nuclear, chemical or biological weapons or missiles, nor shall they use Bourns® products or technology in any facility which engages in activities relating to such devices. The foregoing restrictions apply to all uses and applications that violate national or international prohibitions, including embargos or international regulations. Further, Bourns® products and Bourns technology and technical data may not under any circumstance be exported or re-exported to countries subject to international sanctions or embargoes. Bourns® products may not, without prior authorization from Bourns and/or the U.S. Government, be resold, transferred, or re-exported to any party not eligible to receive U.S. commodities, software, and technical data.

To the maximum extent permitted by applicable law, Bourns disclaims (i) any and all liability for special, punitive, consequential, incidental or indirect damages or lost revenues or lost profits, and (ii) any and all implied warranties, including implied warranties of fitness for particular purpose, non-infringement and merchantability.

For your convenience, copies of this Legal Disclaimer Notice with German, Spanish, Japanese, Traditional Chinese and Simplified Chinese bilingual versions are available at:

Web Page: <http://www.bourns.com/legal/disclaimers-terms-and-policies>

PDF: <http://www.bourns.com/docs/Legal/disclaimer.pdf>