

Wire Bondable Vertical Silicon Capacitor WBSC / WLSC

0202 100pF BV150



Rev.2.10

General description

WBSC / WLSC Capacitors targets power supplies decoupling and filtering of active devices. They are based on PICS Integrated Passive technology.

This product is a single 100pF capacitor array in a 0202 package size. Other capacitance values and other package size are available as a single die or capacitor array; please feel free to contact us.

WBSC / WLSC capacitors are directly mounted on the PCB application using die bonding or wire bonding processes. Standard FR4 PCB can be used. The bottom electrode is in TiNiAu and the top electrode is in TiWAu. Other top finishings such as Aluminum are available on request.

Key features

- Compatible with MLCC footprint
- Ultra-high stability of capacitance value:
 - Temperature 70ppm/K (-55 °C to +150 °C)
 - Voltage <0.02%/Volt
- Negligible capacitance loss through ageing
- Low profile 250µm or 100µm
- Small size 0.5 x 0.5 mm (0202 format)
- Break down voltage : 150V
- Low leakage current
- High reliability
- High operating temperature (up to 150 °C)
- Compatible with high temperature cycling during manufacturing operations (exceeding 300 °C)
- Compatible with EIA 0202 footprint
- Applicable for standard wire bonding assembly (ball and wedge)

Key applications

- Any demanding applications, such as medical, aerospace, automotive industrial...
- Supply decoupling / filtering of active device
- High reliability applications
- High temperature applications
- High volumetric efficiency (*i.e. capacitance per unit volume*)



Functional diagram

The next figure provides implementation set-up diagram.



Figure 1 Block Diagram

Electrical performances

Symbol	Parameter	Conditions	Min.	Typ.	Max.	Unit
C	Capacitance value	@+25°C	-	100	-	pF
ΔC_P	Capacitance tolerance ⁽¹⁾	@+25°C	-15	-	+15	%
T _{OP}	Operating temperature		-55	20	150	°C
T _{STG}	Storage temperature ⁽²⁾		-70	-	165	°C
ΔC_T	Capacitance temperature variation	-55°C to +150°C		70		ppm/K
RV _{DC}	Rated voltage ⁽³⁾		-	50	68 ⁽⁴⁾ 61 ⁽⁵⁾	V _{DC}
BV	Breakdown voltage	@+25°C	150	-	-	V _{DC}
ΔC_{RVDC}	DC Capacitance voltage variation	From 0V to RV _{DC} , @25°C	-	-	0.02	%/V _{DC}
IR	Insulation resistance	@ RV _{DC} , +25°C, 120s	-	10	-	GΩ
ESR	Equivalent Series Resistance	@+25°C, shunt mode	-	10	-	mΩ
ESL	Equivalent Series Inductance	@+25°C, SRF shunt mode	-	10	-	pH
ESD	HBM stress ⁽⁶⁾	JS-001-2017	500	-	-	V

Table 1 - Electrical performances

- (1): other tolerance available upon request
- (2): without packaging
- (3): Lifetime is voltage and temperature dependent, please refer to application note 'Lifetime of 3D capacitors'
- (4): 10 years of intrinsic life time prediction at 100°C continuous operation
- (5): 10 years of intrinsic life time prediction at 150°C continuous operation
- (6): please refer to application note 'ESD Challenge in 3D Murata Integrated Passive technology'

For extended frequency range (up to 26GHz), see Ultra large band Wire bonding vertical Silicon Capacitor (UWSC).



Pinning definition

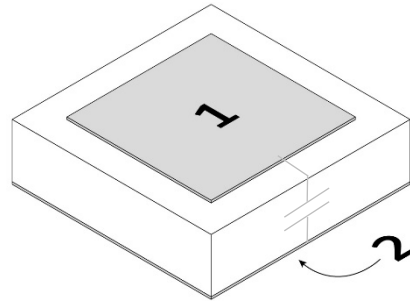

Figure 2 Pinning definition

pin #	Symbol	Coordinates X / Y
1	Signal	0.0 / 0.0
2	GND	Backside

Table 2 - Pinning description. Reference (0,0) located at the centre of the die.

Ordering Information

Regardless of packaging, Murata Integrated Passive Devices delivers products with AQL level II (0.65).

Type number	Package		
	Packaging	Finishing	Description
935142521310-F1T	6" FFC ⁽¹⁾	Au ⁽²⁾	WBSC 100pF/0202 1 bondpad – 0.50 x 0.50mm x 0.25mm ⁽³⁾
935142521310-F2T	8" FFC ⁽¹⁾	Au ⁽²⁾	
935142521310-E1T	6" expander grip ring ⁽¹⁾	Au ⁽²⁾	
935142521310-T3T	T&R 1Kunits ⁽⁴⁾	Au ⁽²⁾	
935142521310-W0T	Waffle pack 400units	Au ⁽²⁾	
935146521310-F1T	6" FFC ⁽¹⁾	Au ⁽²⁾	WLSC 100pF/0202 1 bondpad – 0.50 x 0.50mm x 0.10mm ⁽³⁾
935146521310-F2T	8" FFC ⁽¹⁾	Au ⁽²⁾	
935146521310-E1T	6" expander grip ring ⁽¹⁾	Au ⁽²⁾	
935146521310-T3T	T&R 1Kunits ⁽⁴⁾	Au ⁽²⁾	
935146521310-W0T	Waffle pack 400units	Au ⁽²⁾	

(1) Other film frame carrier are possible on request
 (2) Au = TiWAu (0.3µm) / Au (3µm)
 (3) Refer to Figure 7
 (4) missing capacitors can reach 0.5%

Table 3 - Packaging and ordering information

Product Name	Die Name	Description
WBSC521.310	WO0202310	WBSC 100pF/0202/BV150– 1 bondpad – 0.50 x 0.50mm x 0.25mm
WLSC521.310	WO0202310	WLSC 100pF/0202/BV150– 1 bondpad – 0.50 x 0.50mm x 0.10mm

Table 4 - Die information



Pad Metallization

The wire bondable capacitor like WBSC / WLSC is delivered as standard with the bottom electrode in TiNiAu (Ti=0.1 μ m; Ni=0.3 μ m; Au=0.2 μ m) and top electrode in TiWAu (0.3 μ m) / Au (3 μ m).

Other Metallization, such as Thick Gold or Aluminum pads are possible on request.

WBSC / WLSC capacitors are directly mounted on the PCB application using die bonding and wire bonding. It is applicable for standard wire bonding assembly (ball and wedge).

Silicon dies are not sensitive to humidity, please refer to applications notes 'Assembly Notes' section 'Handling precautions and storage'.

For further information, please see our mounting application note.

Material regulation

This product is RoHS compliant at the time of publication. For further information about regulation compliancy, please ask your sales representative.

Package outline

The product is delivered as a bare silicon die.

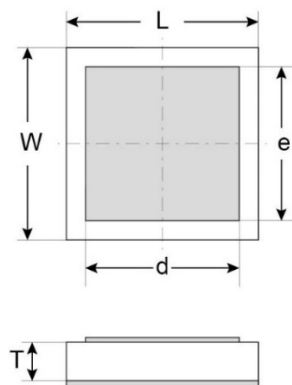

Figure 3 - Package outline drawing

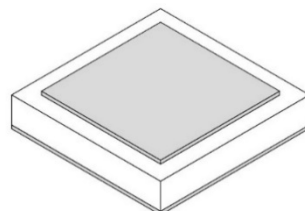

Figure 4 - Package isometric view



L (mm)	W (mm)	T (mm)	d (mm)	e (mm)
0.50 ±0.03	0.50 ±0.03	0.25 or 0.10 ±0.015	0.4	0.4

Table 5 - Dimensions and tolerances

Assembly

The attachment techniques recommended by Murata on the customer’s substrates are fully detailed in specific documents available on our website. To assure the correct use and proper functioning of Murata capacitors **please download the assembly instructions on <https://www.murata.com/en-us/products/capacitor/siliconcapacitors> and read them carefully.**



Figure 5 Scan this QR Code to access the Murata Silicon Capacitor web page

Packaging format

Please refer to application note ‘Products Storage Conditions and Shelf Life’.

Tape and Reel:

Die orientation (No flip) within the case related to T&R orientation)

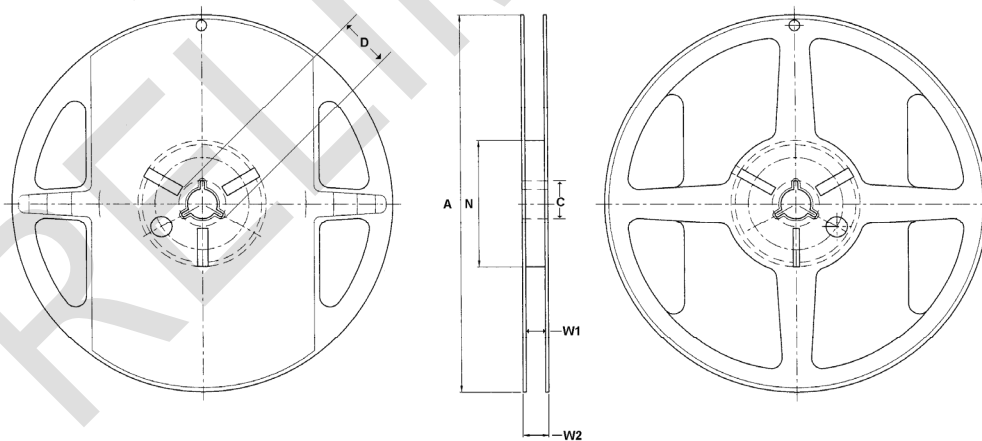

Figure 6 - Reel drawing

Tape Width	Diameter A	C	D	Hub N	W1	W2
8	178 (7 inches)	13.5	20.2	60	9.3	11.5



Table 6 – Reel dimensions (mm)

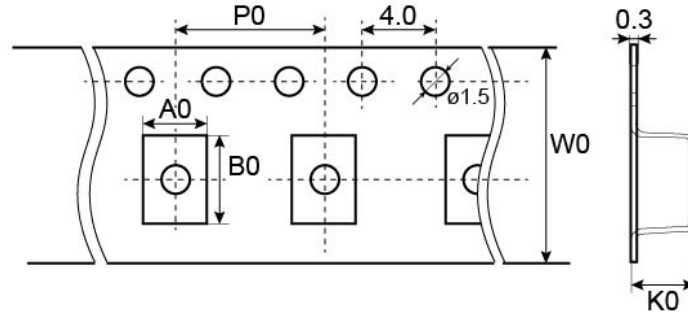

Figure 7 - Tape drawing

Cavity dimensions			Carrier tape width W0	Carrier tape pitch P0	Reel Capacity
Ao	Bo	Ko			
0.56	0.56	0.31	8 mm	4mm	1000

Table 7 - Tape dimensions (mm)



Waffle pack:

Please refer to application note 'Waffle Pack Chip Carrier Handling & Opening Procedure'. Dies are not flipped in the waffle pack cavity (wire bond pad up).

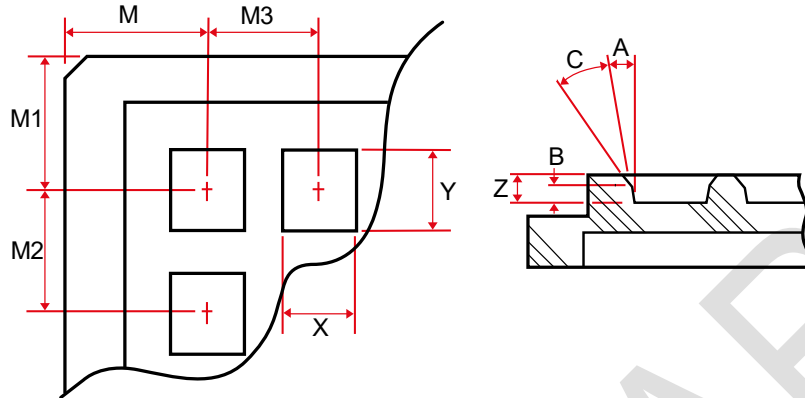

Table 8 - Waffle pack drawing

External dimensions	Max. capacity	Pocket length X	Pocket width Y	Pocket depth Z
2 inches	20 x 20	0.64 ±0.05	0.64 ±0.05	0.36 ±0.05

Table 9 - Waffle pack dimensions (mm) for 250µm thick product

M	M1	M2	M3	A
4.65 ±0.08	4.65 ±0.08	2.18 ±0.05	2.18 ±0.05	15° ±1/2°

Table 10 - Waffle pack dimensions (mm) for 250µm thick product

External dimensions	Max. capacity	Pocket length X	Pocket width Y	Pocket depth Z
2 inches	20 x 20	0.58 ±0.05	0.58 ±0.05	0.28 ±0.05

Table 11 : Waffle pack dimensions (mm) for 100µm thick product

M	M1	M2	M3	A
4.89 ±0.08	4.89 ±0.08	2.16 ±0.05	2.16 ±0.05	18° ±1/2°

Table 12 : Waffle pack dimensions (mm) for 100µm thick product



Film Frame Carrier:

With UV curable dicing tape (UV performed).

Good dies are identified using the SINF electronic mapping format. No ink is added on wafer to label other dies.

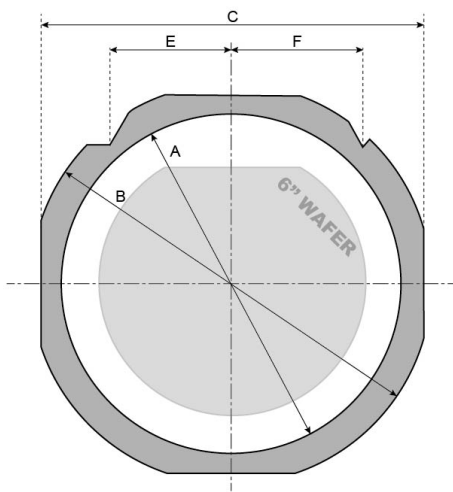

Figure 8 FF070 Frame with a 6" wafer

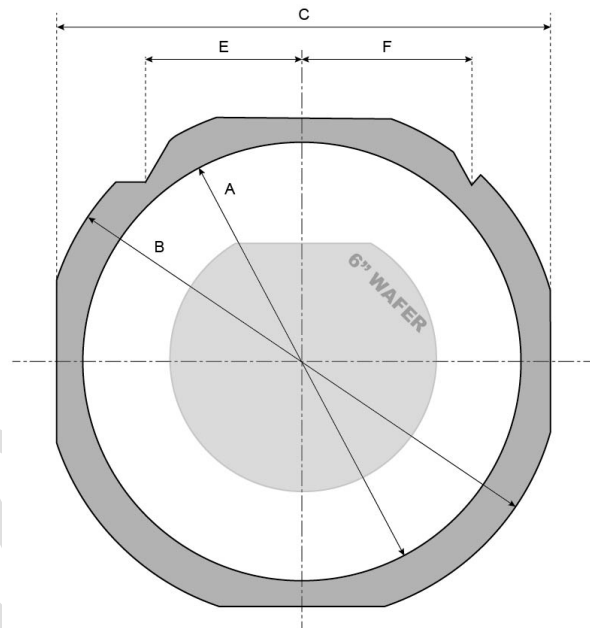

Figure 9 FF108 Frame with a 6" wafer

Frame Reference	Frame Style	Inside diameter A	Outside diameter B	Width C	Thickness	Pin location E	Pin location F
FF070 (1)	DTF-2-6-1	7.638"	8.976"	8.346"	0.048"	2.370"	2.5"
FF108 (1)	DTF-2-8-1	9.842"	11.653"	10.866"	0.048"	2.381"	2.5"

Table 13 - Frame dimensions (inches)

(1) or equivalent



Expander grip ring 6" diameter:

With UV curable dicing tape (UV performed)

Good dies are identified using the SINF electronic mapping format. No ink is added on wafer to label other dies.

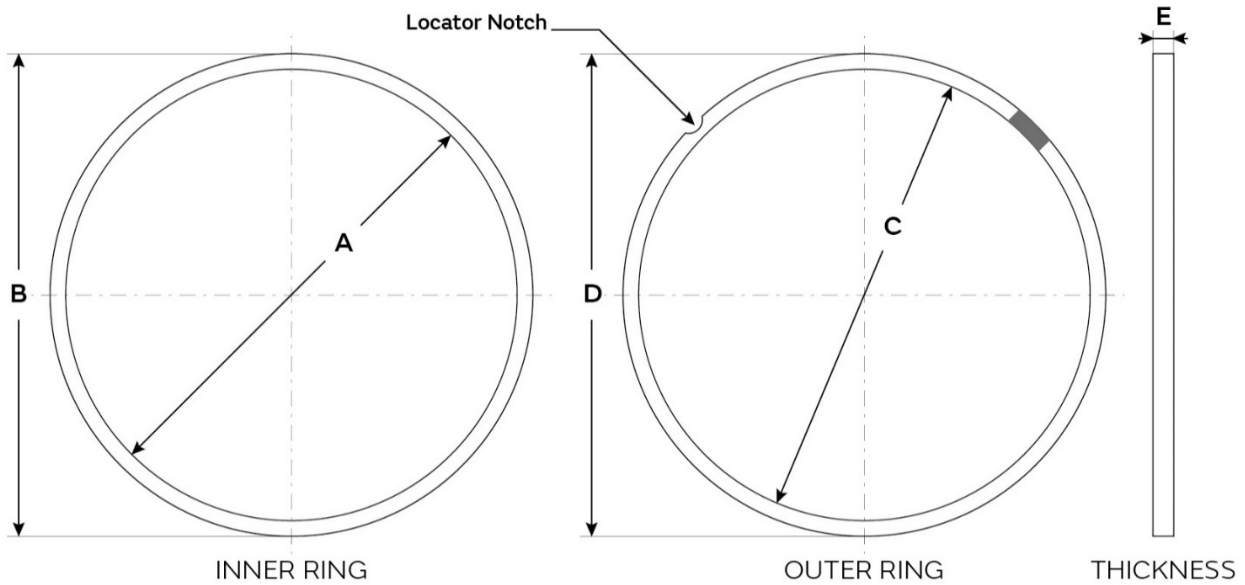

Figure 10 – Grip Ring drawing

Grip Ring Style	A	B	C	D	E	Locator Notch
GRP-2620-6 ⁽¹⁾	7.670"	7.973"	7.975"	8.280"	0.236"	None

Table 14 - Frame dimensions (inches)

(1) or equivalent

PRELIMINARY



Definitions

Data sheet status

Objective specification: This data sheet contains target or goal specifications for product development.

Preliminary specification: This data sheet contains preliminary data; supplementary data may be published later.

Product specification: This data sheet contains final product specifications.

Limiting values

Stress above one or more of the limiting values may cause permanent damage to the device. These are stress ratings only and operation of the device at these or any other conditions above those given in the Electrical performances sections of this specification is not implied. Exposure to limiting values for extended periods may affect device reliability.

Application information

Where application information is given, it is advisory and does not form part of the specification.

Revision history

Revision	Date	Description	Author
Rev 1.00	2014 May 12 th	Creation	OGA
Rev 2.01	2021 Feb 23 rd	Content and Layout update	LLE / CGU / OGA / SCA
Rev 2.02	2021 April 2 nd	Minor update	LLE / CGU / OGA / SCA
Rev 2.10	2022 Feb 9 th	ESD performance update	SCA

Disclaimer / Life support applications

These products are not designed for use in life support appliances, devices, or systems where malfunction of these products can reasonably be expected to result in personal injury. Murata customers using or selling these products for use in such applications do so at their own risk and agree to fully indemnify Murata for any damages resulting from such improper use or sale.

Reproduction in whole or in part is prohibited without the prior written consent of the copyright owner. The information presented in this document does not form part of any quotation or contract, is believed to be accurate and reliable and may be changed without notice. No liability will be accepted by the publisher for any consequence of its use. Publication thereof does not convey nor imply any license under patent or other industrial or intellectual property rights.

Murata Integrated Passive Solutions S.A. makes no representation that the use of its products in the circuits described herein, or the use of other technical information contained herein, will not infringe upon existing or future patent rights. The descriptions contained herein do not imply the granting of licenses to make, use, or sell equipment constructed in accordance therewith. Specifications are subject to change without notice.



www.murata.com

mis@murata.com