

Ultra-Large band Silicon Capacitor ULSC 0201 47nF BV11



Rev. 3.06

General description

ULSC Capacitor targets Optical communication system such as ROSA/TOSA, SONET and all optoelectronics as well as High speed data system or products.

The ULSC is suitable for DC blocking, feedback, coupling and bypassing applications in all broadband optoelectronics and High-speed data system.

The unique technology of integrated passive device in silicon, developed by Murata Integrated Passive Solutions, offers unique performances with low insertion loss, low reflection and phase stability from 34 KHz to 28+ GHz.

These capacitors in ultra-deep trenches in silicon have been developed in a semiconductor process, in order to integrate trench MOS capacitor providing high capacitance value of 47 nF (for kHz–MHz range) and high frequency MIM capacitors for low capacitance value for GHz range), combined in a 0201 [0.8x0.6mm] case.

ULSC capacitors have an extended operating temperature ranging from -55 to 150°C, with very low capacitance change over temperature, well as a very high reliability.

Assembly: Suitable for surface mounted application on rigid PCB, ceramic substrate, FR4 (laminated) or flex platforms.

Bump finishing: ENIG

Copper pads optional for embedding version and SAC305 type 6 for pre-bumping version, as an optional finishing.

Key features

- Ultra-Large band performance up to 28 GHz
- Resonance free
- Phase stability
- Insertion loss < 0.2dB Typ. up to 28 GHz
- Ultra-high stability of capacitance value:
 - Temperature 70ppm/K (-55 °C to +150 °C)
 - Voltage < -0.1%/Volt
 - Negligible capacitance loss through ageing
- Low profile: 400µm, 100 µm on request
- Break down voltage: 11V
- Low leakage current
- High reliability
- High operating temperature (up to 150 °C)
- Compatible with high temperature cycling during manufacturing operations (exceeding 300 °C)
- Compatible with EIA 0201 footprint

Key applications

- ROSA/TOSA
- SONET
- High speed digital logic
- Microwave/millimetre system
- High volumetric efficiency (i.e. capacitance per unit volume)
- Broadband test equipment



Functional diagram

The next figure provides implementation set-up diagram.



Figure 1 Block Diagram

Electrical performances

Symbol	Parameter	Conditions	Min.	Typ.	Max.	Unit
C	Capacitance value	@+25°C	-	47	-	nF
ΔC_P	Capacitance tolerance ⁽¹⁾	@+25°C	-15	-	+15	%
T _{OP}	Operating temperature		-55	20	150	°C
T _{STG}	Storage temperature ⁽²⁾		-70	-	165	°C
ΔC_T	Capacitance temperature variation	-55 °C to 150 °C	-	70	-	ppm/K
RV _{DC}	Rated voltage ⁽³⁾		-	-	3.8 ⁽⁴⁾ 3.4 ⁽⁵⁾	V _{DC}
BV	Break down voltage	@+25°C	11	-	-	V
ΔC_{RVDC}	Capacitance voltage variation	From 0 V to RV _{DC} , @+25°C	-	-	- 0.1	%/V _{DC}
IR	Insulation resistor	@RV _{DC} , +25°C, 120s	-	10	-	GΩ
ESL	Equivalent Serial Inductance	@+25°C, SRF shunt mode	-	20	-	pH
ESR	Equivalent Serial Resistance	@+25°C, shunt mode	-	220	-	mOhm
F _{C-3dB}	Cut-off frequency at 3dB	@+25°C	-	34	40	kHz
IL	Insertion loss	@ 28 GHz, +25°C	-	0.2	-	dB
RL	Return loss	Up to 28 GHz, +25°C	26	-	-	dB
ESD	HBM stress ⁽⁶⁾	JS-001-2017	2	-	-	kV

Table 1 - Electrical performances

⁽¹⁾: other tolerance available upon request.

⁽²⁾: without packaging.

⁽³⁾: Lifetime is voltage and temperature dependent, please refer to application note 'Lifetime of 3D capacitors'.

⁽⁴⁾: 10 years of intrinsic lifetime prediction at 100°C continuous operation.

⁽⁵⁾: 10 years of intrinsic lifetime prediction at 150°C continuous operation.

⁽⁶⁾: please refer to application note 'ESD Challenge in 3D Murata Integrated Passive technology'.

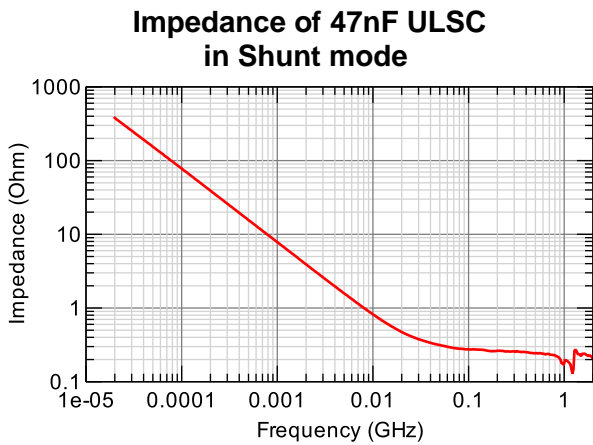

Figure 2 - 47nF ULSC Measured results (module of Z-parameters)

Module of S-parameters of 47nF ULSC in transmission mode

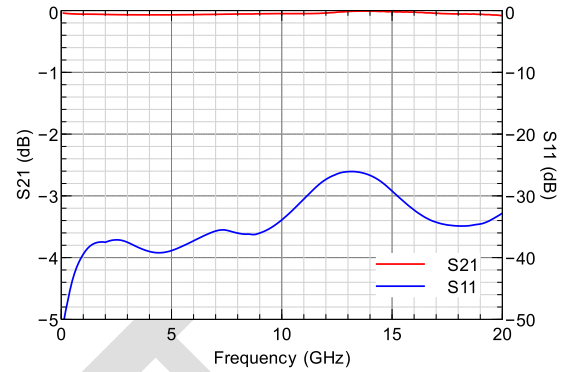
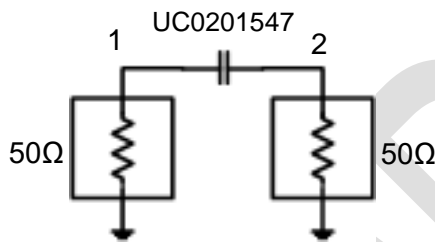

Figure 3 - 47nF ULSC Measured results (module of S-parameters)

Schematic of 47nF ULSC in transmission mode



6.6-mil Rogers 4350B.

Microstrip mode – line width = 0.400mm and gap = 0.300 mm. (nominal 50-ohm characteristic impedance).

Figure 4 - 47nF ULSC measurement schematic

Example of 0201 surface mounted

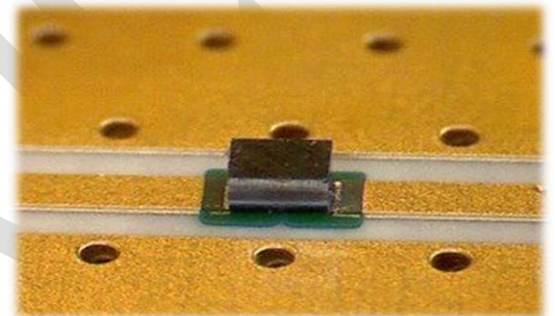

Figure 5 – micro picture of ULSC mounted on board in coplanar mode



Pinning definition

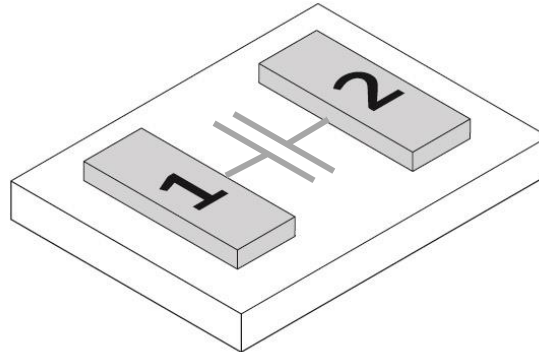

Figure 6 Pin configuration

pin #	Symbol	Coordinates X / Y
1	Signal	-225.0 / 0.0
2	Signal	225.0 / 0.0

Table 2 - Pining description. Reference (0,0) located at the centre of the die.

Ordering Information for ULSC493.547

Regardless of packaging, Murata Integrated Passive Devices delivers products with AQL level II (0.65).

Type number	Package		
	Packaging	Finishing	Description
935155493547-T3N	T&R 1 000units ⁽³⁾	ENIG ⁽²⁾	ULSC 0201 - 47nF – 2 pads – 0.8 x 0.6 mm x 0.40mm ⁽⁴⁾
935156493547-T3N	T&R 1 000units ⁽³⁾	ENIG ⁽²⁾	ULSC 0201 - 47nF – 2 pads – 0.8 x 0.6 mm x 0.10mm ⁽⁴⁾
935156493547-T5N	T&R 5 000units ⁽³⁾	ENIG ⁽²⁾	ULSC 0201 - 47nF – 2 pads – 0.8 x 0.6 mm x 0.10mm ⁽⁴⁾
935156493547-T3S	T&R 1 000units ⁽³⁾	ENIG ⁽²⁾ + SAC	ULSC 0201 - 47nF – 2 pads – 0.8 x 0.6 mm x 0.10mm ⁽⁴⁾
935156493547-T5S	T&R 5 000units ⁽³⁾	ENIG ⁽²⁾ + SAC	ULSC 0201 - 47nF – 2 pads – 0.8 x 0.6 mm x 0.10mm ⁽⁴⁾

(1) Other film frame carrier are possible on request

(2) With N = ENIG = 0.1µm Au / 5µm Ni

(3) missing capacitors can reach 0.5%

(4) refer to Figure 10

& with S = SAC305 type6 re-bumping

Table 3 - Packaging and ordering information

Product Name	Die Name	Description
ULSC493.547	UC0201547	ULSC 47nF/0201/BV11 – 2 pads – 0.8 x 0.6 mm x 0.40mm
ULSC493.547	UC0201547	ULSC 47nF/0201/BV11 – 2 pads – 0.8 x 0.6 mm x 0.10mm

Table 4 - Die information



Pad Metallization

The Surface Mounted Capacitor is delivered as standard with NiAu finishing [ENIG (0.1µm Au / 5µm Ni)] (Refer to Figure7).

Other Metallization, such as SAC305 type6 (Refer to Figure8). Copper, thick Gold or Aluminum pads are possible on request.

Silicon dies are not sensitive to humidity, please refer to applications notes 'Assembly Notes' section 'Handling precautions and storage'.

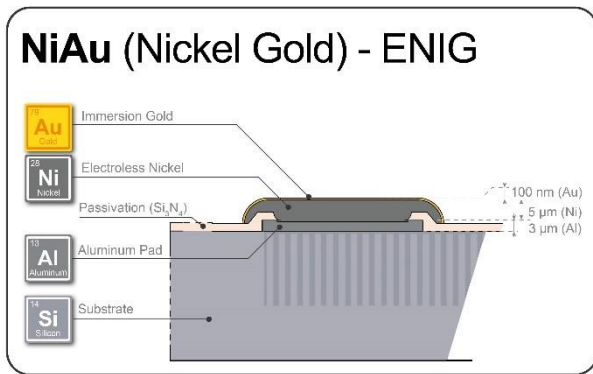

Figure 7 – Top electrode description of ENIG finishing version

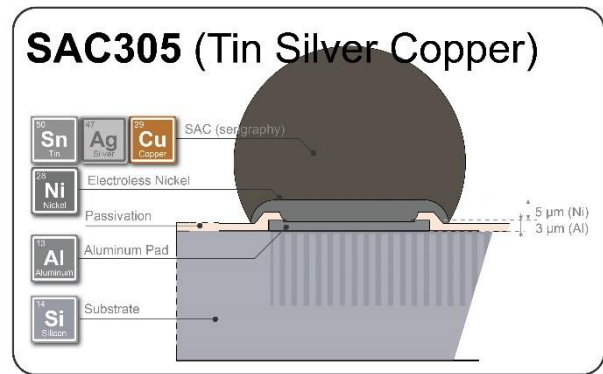

Figure 8 – Top electrode description of SAC305 pre-bumped version

Material regulation

This product is RoHS compliant at the time of publication. For further information about regulation compliancy, please ask your sales representative.



Package outline

The product is delivered as a bare silicon die.

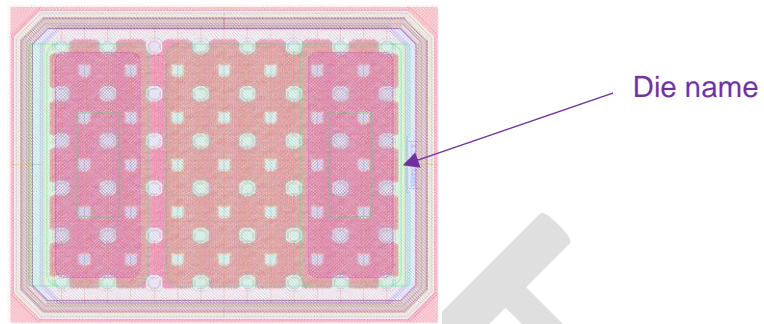

Figure 9 – Layout view

L (mm)	W (mm)	T (mm)	a (mm)	P (mm)	b (mm)	t (mm)
0.80 ±0.04	0.60 ±0.04	0.40 or 0.10 ±0.02	0.15	0.30	0.40	0.005±0.002 ⁽¹⁾ or 0.04 ⁽²⁾ 0.065 ⁽³⁾

- (1) Only in case of ENIG finishing
- (2) Solder joint height after reflow on board in case of SAC305 pre-bumping with mirror pads on board
- (3) Solder bump height before assembly

Table 5 - Dimensions and tolerances

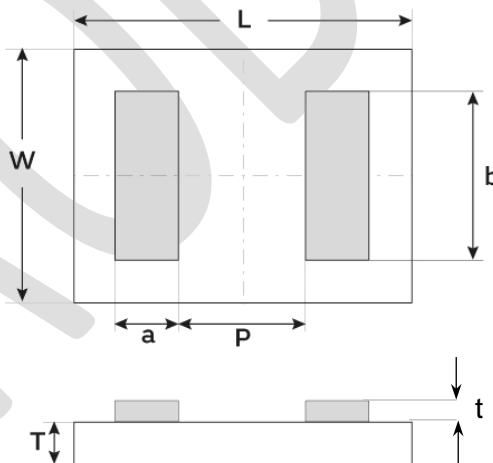

Figure 10 - Package outline drawing

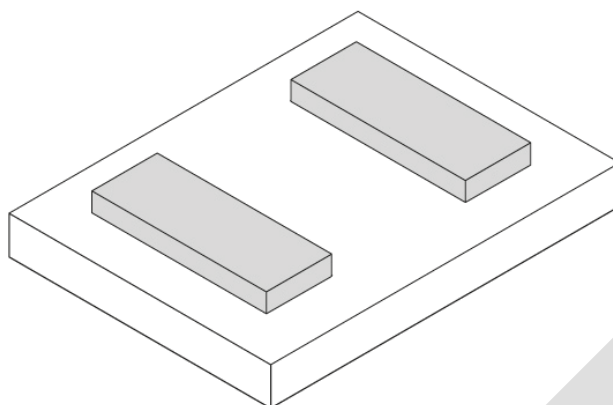

Figure 11 - Package isometric view

PRODUCT



Assembly

ULSC series is compatible with standard reflow technology.

It is recommended to design mirror pads on the PCB.

For further information, please see our mounting application note.

The attachment techniques recommended by Murata on the customer's substrates are fully detailed in specific documents available on our website. To assure the correct use and proper functioning of Murata capacitors **please download the assembly instructions on <https://www.murata.com/en-us/products/capacitor/siliconcapacitors> and read them carefully.**



Figure 12 Scan this QR Code to access the Murata Silicon Capacitor web page

Packaging format

Please refer to application note 'Products Storage Conditions and Shelf Life'.

Tape and Reel: Dies are flipped in the tape cavity (bump down) with die ID located near the driving holes of the tape.

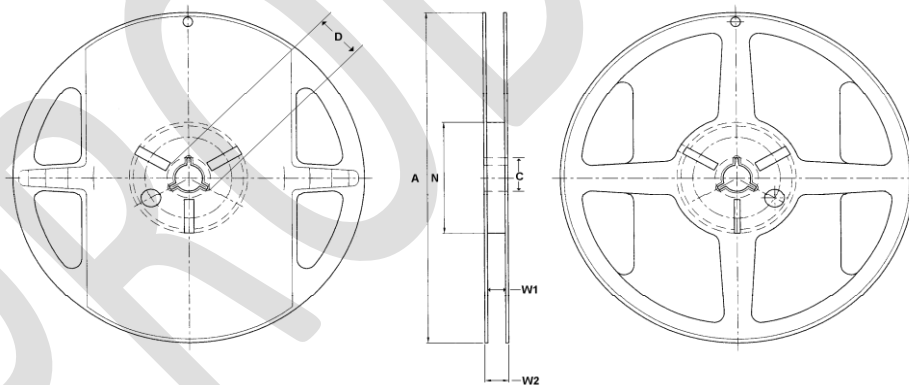

Figure 13 - Reel drawing

Tape Width	Diameter A	C	D	Hub N	W1	W2
8	178 (7 inches)	13.5	20.2	60	9.3	11.5

Table 6 - Reel dimensions (mm)

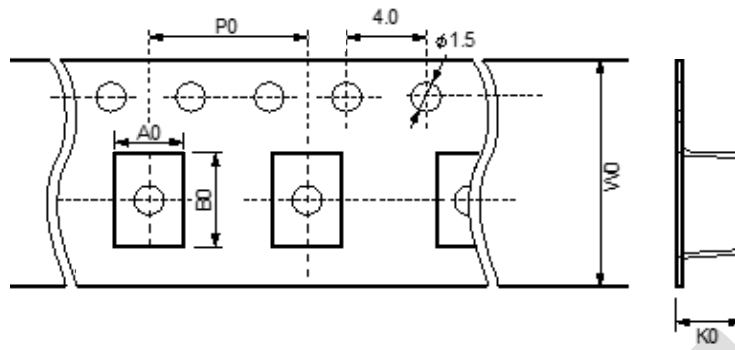

Figure 14 – Tape drawing (not to scale)

Cavity dimensions			Carrier tape width W0	Carrier tape pitch P0	Quantity per reel	Die thickness
A0	B0	K0				T(mm)
0.76	0.96	0.22	8	2	1 000	100µm
tbd	tbd	tbd	8	2	5 000	100µm
0.74	0.94	0.57	8	4	1 000	400µm

Table 7 - Tape dimensions (mm)



Definitions

Data sheet status

Objective specification: This data sheet contains target or goal specifications for product development.

Preliminary specification: This data sheet contains preliminary data; supplementary data may be published later.

Product specification: This data sheet contains final product specifications.

Limiting values

Stress above one or more of the limiting values may cause permanent damage to the device. These are stress ratings only and operation of the device at these or any other conditions above those given in the Electrical performances sections of this specification is not implied. Exposure to limiting values for extended periods may affect device reliability.

Application information

Where application information is given, it is advisory and does not form part of the specification.

Revision history

Revision	Date	Description	Author
Release 1.00	2016 November 07th	Objective specification	OGA
Release 1.05	2021 March 16th	Minor update	OGA
Release 2.00	2021 April 21th	Minor update	OGA
Release 3.00	2021 June 25th	Product release	OGA, LLR, CGU, SCA, DDE, DY0, SY0
Release 3.01	2022 Jan 25th	Typo on the reference	OGA
Release 3.02	2022 Feb 16th	Typo on the thickness tolerance + PN with 5Kpcs / reel	OGA
Release 3.03	2023 May 10th	Bump cross section adding	OGA
Release 3.04	2023 July 06th	Typo update	OGA
Release 3.06	2023 Sept 20th	Extension of max. frequency guaranteed	OGA

Disclaimer / Life support applications

These products are not designed for use in life support appliances, devices, or systems where malfunction of these products can reasonably be expected to result in personal injury. Murata customers using or selling these products for use in such applications do so at their own risk and agree to fully indemnify Murata for any damages resulting from such improper use or sale.

Reproduction in whole or in part is prohibited without the prior written consent of the copyright owner. The information presented in this document does not form part of any quotation or contract, is believed to be accurate and reliable and may be changed without notice. No liability will be accepted by the publisher for any consequence of its use. Publication thereof does not convey nor imply any license under patent or other industrial or intellectual property rights.

Murata Integrated Passive Solutions S.A. makes no representation that the use of its products in the circuits described herein, or the use of other technical information contained herein, will not infringe upon existing or future patent rights. The descriptions contained herein do not imply the granting of licenses to make, use, or sell equipment constructed in accordance therewith. Specifications are subject to change without notice.



www.murata.com

mis@murata.com