

Evaluating the ADRF5030 Silicon SPDT Switch, Non-Reflective, 100 MHz to 20 GHz

FEATURES

- ▶ Full-featured evaluation board for the [ADRF5030](#)
- ▶ Easy connection to the test equipment
- ▶ Thru line for calibration

EVALUATION KIT CONTENTS

- ▶ ADRF5030-EVALZ evaluation board

EQUIPMENT NEEDED

- ▶ DC power supplies
- ▶ Network analyzer

DOCUMENTS NEEDED

- ▶ ADRF5030 data sheet

GENERAL DESCRIPTION

The ADRF5030 is a single-pole, double-throw (SPDT) switch manufactured in the silicon process.

This user guide describes the ADRF5030-EVALZ evaluation board, designed to evaluate the features and performance of the ADRF5030. [Figure 1](#) shows a photograph of the evaluation board.

Full specifications on the ADRF5030 are available in the ADRF5030 data sheet from Analog Devices. Consult it with this user guide when using the ADRF5030-EVALZ evaluation board.

EVALUATION BOARD PHOTOGRAPH

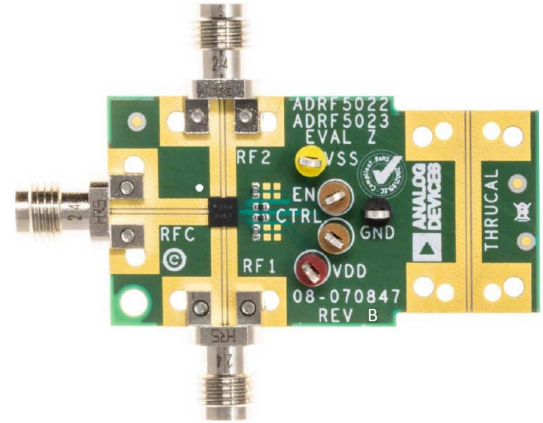

Figure 1. ADRF5030-EVALZ Evaluation Board Photograph

001

TABLE OF CONTENTS

Features.....	1	Power-Supply and Control Inputs.....	3
Evaluation Kit Contents.....	1	RF Inputs and Outputs	3
Equipment Needed.....	1	Test Procedure.....	5
Documents Needed.....	1	Biasing Sequence.....	5
General Description.....	1	Evaluation Board Schematic and Assembly	
Evaluation Board Photograph.....	1	Diagram.....	6
Evaluation Board Hardware.....	3	Ordering Information.....	7
Overview.....	3	Bill of Materials.....	7
Board Layout.....	3		

REVISION HISTORY**7/2024—Revision 0: Initial Version**

EVALUATION BOARD HARDWARE

OVERVIEW

The ADRF5030-EVALZ is a connectorized board, assembled with the ADRF5030 and its application circuitry. All components are placed on the primary side of the ADRF5030-EVALZ evaluation board. Figure 6 shows an assembly drawing for the ADRF5030-EVALZ and Figure 5 shows an evaluation board schematic.

BOARD LAYOUT

The ADRF5030-EVALZ evaluation board is designed using RF circuit design techniques on a four-layer printed circuit board (PCB). Figure 2 shows the PCB stack-up.

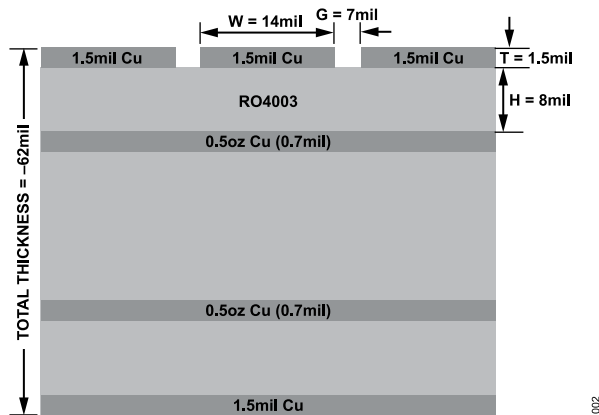

Figure 2. Evaluation Board Stack-Up

The outer copper layers are 1.5 mil thick and the inner layers are 0.7 mil thick.

All RF and DC traces are routed on the top copper layer, whereas the inner and bottom layers are grounded planes that provide a solid ground for the RF transmission lines. The top dielectric material is 8 mil Rogers RO4003, offering optimal high-frequency performance. The middle and bottom dielectric materials provide mechanical strength. The total board thickness is 62 mil, which allows 2.4 mm RF edge launch connectors to be placed at the board edges.

The RF transmission lines are designed using a coplanar waveguide (CPWG) model with a width of 14 mil and ground spacing of 7 mil to have a characteristic impedance of 50 Ω. Ground via fences is arranged on both sides of a CPWG to improve isolation between nearby RF lines and other signal lines.

POWER-SUPPLY AND CONTROL INPUTS

The ADRF5030-EVALZ evaluation board has two power-supply inputs, two control inputs, and a ground, as shown in Table 1. The DC test points are populated on V_{DD}, V_{SS}, CTRL, and GND. A 3.3 V supply is connected to the DC test points on V_{DD}, and a -3.3 V supply is connected to the DC test points on V_{SS}. Ground reference can be connected to GND. Connect the control input, CTRL, to 3.3 V or 0 V. The typical total current consumption for the ADRF5030 is 670 μA.

The V_{DD} and V_{SS} supply pins of the ADRF5030 are decoupled with 100 pF capacitors.

Table 1. Power-Supply and Control Inputs

Test Points	Description
V _{DD}	Positive supply voltage
V _{SS}	Negative supply voltage
CTRL	CONTROL input voltage
EN	EN input voltage
GND	Ground

RF INPUTS AND OUTPUTS

The ADRF5030-EVALZ evaluation board has five edge-mounted, 2.4 mm connectors for the RF inputs and outputs, as shown in Table 2.

Table 2. RF Inputs and Outputs

2.4 mm Connectors	Description
RFC	RF common port
RF1	RF Throw Port 1
RF2	RF Throw Port 2
THRU1	Thru line input and output
THRU2	Thru line input and output

The through calibration line, connecting the THRU1 and THRU2 RF connectors, calibrates out the board loss effects from the measurements of the ADRF5030-EVALZ evaluation board to determine the device performance at the pins of the IC. Figure 3 shows the typical board loss for the ADRF5030-EVALZ evaluation board at room temperature, as well as the embedded and de-embedded insertion loss for the ADRF5030.

EVALUATION BOARD HARDWARE

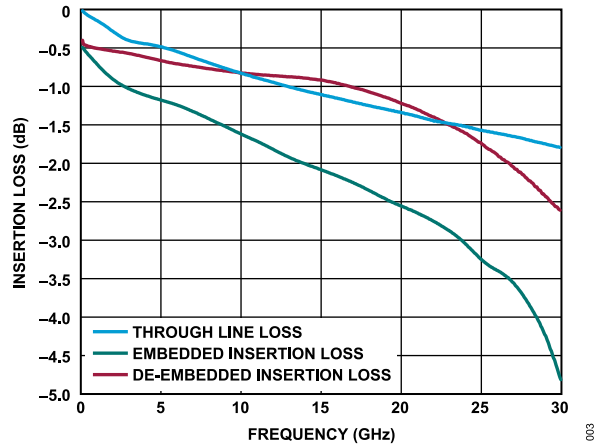

Figure 3. Insertion Loss vs. Frequency

TEST PROCEDURE

BIASING SEQUENCE

To bias up the ADRF5030-EVALZ evaluation board, follow these steps:

1. Ground the GND test point.
2. Bias up the V_{DD} test point.
3. Bias up the V_{SS} test point.
4. Bias up the CTRL test point.
5. Bias up the EN test point.
6. Apply an RF input signal.

The ADRF5030-EVALZ evaluation board is shipped fully assembled and tested. Figure 4 provides a basic test setup diagram to evaluate the s-parameters using a network analyzer. Follow these steps to complete the test setup and verify the operation of the ADRF5030-EVALZ evaluation board:

1. Connect the GND test point to the ground terminal of the power supply.
2. Connect the V_{DD} test point to the voltage-output terminal of the 3.3 V supply.
3. Connect the V_{SS} test point to the voltage-output terminal of the -3.3 V supply.
4. Connect the CTRL test point to the voltage-output terminal of the 3.3 V supply. The ADRF5030 can be configured in different modes by connecting the CTRL test point to 3.3 V or 0 V, as shown in Table 3.
5. Connect the EN test point to the voltage-output terminal of the 3.3 V supply. The ADRF5030 can be configured in different modes by connecting the EN test point to 3.3 V or 0 V, as shown in Table 3.
6. Connect a calibrated network analyzer to the RFC, RF1, and RF2 2.4 mm connectors. If the network analyzer port count is not enough, terminate unused RF ports with 50 Ω . Sweep the frequency from 10 MHz to 30 GHz and set the power to -10 dBm.

Additional test equipment is needed to fully evaluate the device's functions and performance.

For third-order intercept point evaluation, use two signal generators and a spectrum analyzer. A high-isolation power combiner is also recommended.

For power compression and power handling evaluations, use a two-channel power meter and a signal generator. A high enough power amplifier is also recommended at the input. Test accessories, such as couplers and attenuators, must have enough power handling.

Note that the measurements performed at the 2.4 mm connectors of the ADRF5030-EVALZ evaluation board include the losses of the 2.4 mm connectors and the PCB. The thru line must be measured to calibrate out the effects on the ADRF5030-EVALZ evaluation board. The thru line is the summation of an RF input line and an RF output line connected to the device and equal in length.

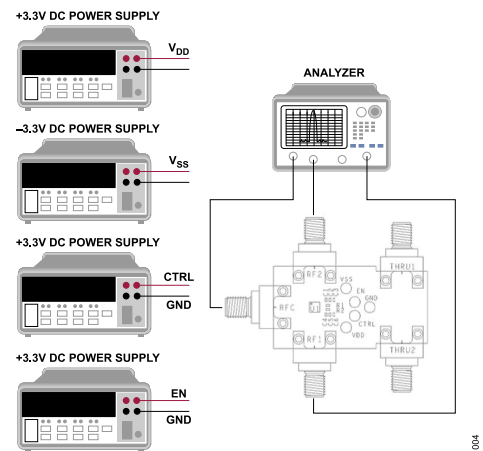

Figure 4. Test Setup Diagram

Table 3. Control Voltage Truth Table

Digital Control Inputs		RF Paths	
EN	CTRL	RF1 to RFC	RF2 to RFC
Low	Low	Isolation (off)	Insertion loss (on)
Low	High	Insertion loss (on)	Isolation (off)
High	Low	Isolation (off)	Isolation (off)
High	High	Isolation (off)	Isolation (off)

EVALUATION BOARD SCHEMATIC AND ASSEMBLY DIAGRAM

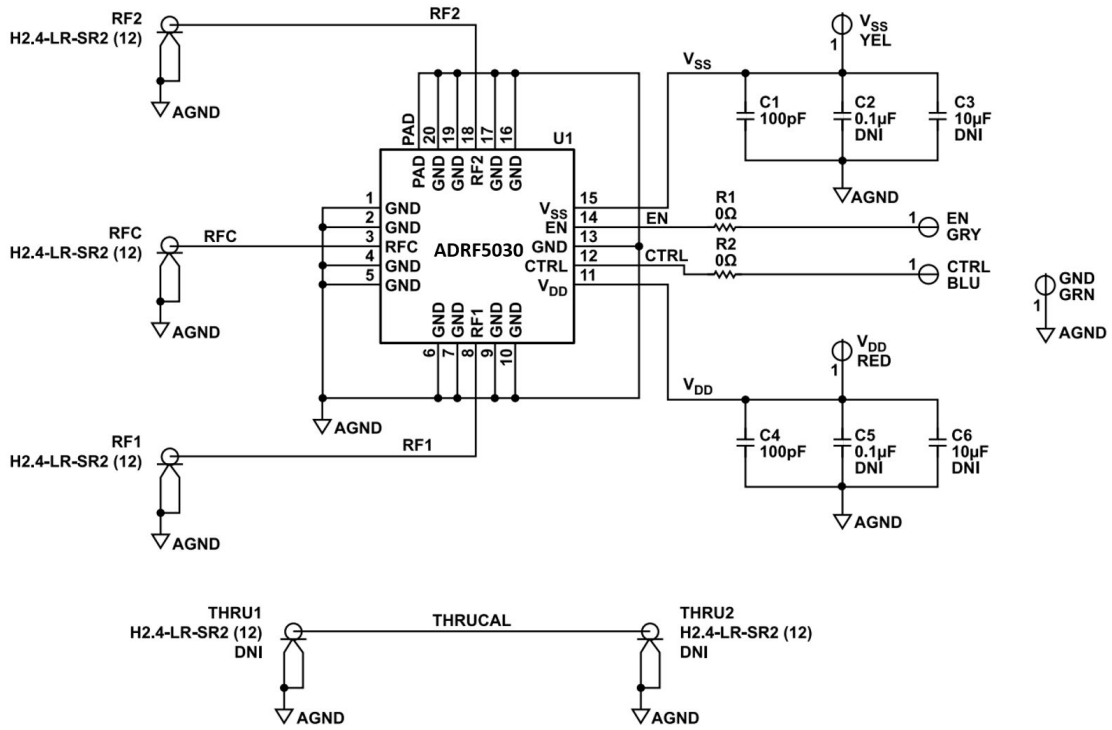

Figure 5. ADRF5030-EVALZ Evaluation Board Schematic

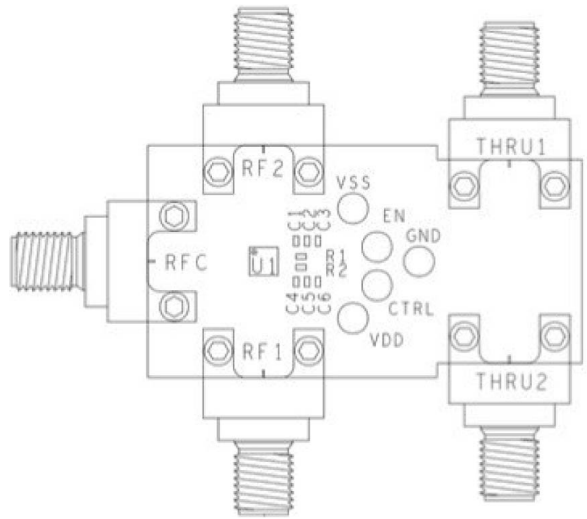

Figure 6. ADRF5030-EVALZ Evaluation Board Assembly Diagram

ORDERING INFORMATION

BILL OF MATERIALS

Table 4. Bill of Materials for ADRF5030-EVALZ

Quantity	Reference Designator	Description	Manufacturer	Part Number
2	C1, C4	Capacitors, 100 pF, 50 V, C0402 package	TDK	C1005NP01H101J050BA
2	C2, C5	Capacitors, 0.1 μF, 16 V, C0402 package, do not insert (DNI)	Samsung	CL05B104K05NNNC
2	C3, C6	Capacitors, 10 μF, 10 V, C0402 package (DNI)	Samsung	CL05A106MP5NUNC
2	R1, R2	Resistors, 0 Ω, 0.1 W, 0402 package	Panasonic	ERJ-2GE0R00X
5	RFC, RF1, RF2, THRU1, and THRU2	Edge-mount 2.4 mm connectors	Hirose Electric CO.	H2.4-LR-SR2(12)
5	GND, CTRL, EN, V _{DD} , and V _{SS}	Surface-mount test points	Components Corporation	TP104-01
1	U1	Silicon SPDT switch, 100 MHz to 20 GHz	Analog Devices, Inc.	ADRF5030BCCZN
1	PCB	ADRF5030-EVALZ	Analog Devices, Inc.	BR-083554



ESD Caution

ESD (electrostatic discharge) sensitive device. Charged devices and circuit boards can discharge without detection. Although this product features patented or proprietary protection circuitry, damage may occur on devices subjected to high energy ESD. Therefore, proper ESD precautions should be taken to avoid performance degradation or loss of functionality.

Legal Terms and Conditions

By using the evaluation board discussed herein (together with any tools, components documentation or support materials, the "Evaluation Board"), you are agreeing to be bound by the terms and conditions set forth below ("Agreement") unless you have purchased the Evaluation Board, in which case the Analog Devices Standard Terms and Conditions of Sale shall govern. Do not use the Evaluation Board until you have read and agreed to the Agreement. Your use of the Evaluation Board shall signify your acceptance of the Agreement. This Agreement is made by and between you ("Customer") and Analog Devices, Inc. ("ADI"), with its principal place of business at Subject to the terms and conditions of the Agreement, ADI hereby grants to Customer a free, limited, personal, temporary, non-exclusive, non-sublicensable, non-transferable license to use the Evaluation Board FOR EVALUATION PURPOSES ONLY. Customer understands and agrees that the Evaluation Board is provided for the sole and exclusive purpose referenced above, and agrees not to use the Evaluation Board for any other purpose. Furthermore, the license granted is expressly made subject to the following additional limitations: Customer shall not (i) rent, lease, display, sell, transfer, assign, sublicense, or distribute the Evaluation Board; and (ii) permit any Third Party to access the Evaluation Board. As used herein, the term "Third Party" includes any entity other than ADI, Customer, their employees, affiliates and in-house consultants. The Evaluation Board is NOT sold to Customer; all rights not expressly granted herein, including ownership of the Evaluation Board, are reserved by ADI. CONFIDENTIALITY. This Agreement and the Evaluation Board shall all be considered the confidential and proprietary information of ADI. Customer may not disclose or transfer any portion of the Evaluation Board to any other party for any reason. Upon discontinuation of use of the Evaluation Board or termination of this Agreement, Customer agrees to promptly return the Evaluation Board to ADI. ADDITIONAL RESTRICTIONS. Customer may not disassemble, decompile or reverse engineer chips on the Evaluation Board. Customer shall inform ADI of any occurred damages or any modifications or alterations it makes to the Evaluation Board, including but not limited to soldering or any other activity that affects the material content of the Evaluation Board. Modifications to the Evaluation Board must comply with applicable law, including but not limited to the RoHS Directive. TERMINATION. ADI may terminate this Agreement at any time upon giving written notice to Customer. Customer agrees to return to ADI the Evaluation Board at that time. LIMITATION OF LIABILITY. THE EVALUATION BOARD PROVIDED HEREUNDER IS PROVIDED "AS IS" AND ADI MAKES NO WARRANTIES OR REPRESENTATIONS OF ANY KIND WITH RESPECT TO IT. ADI SPECIFICALLY DISCLAIMS ANY REPRESENTATIONS, ENDORSEMENTS, GUARANTEES, OR WARRANTIES, EXPRESS OR IMPLIED, RELATED TO THE EVALUATION BOARD INCLUDING, BUT NOT LIMITED TO, THE IMPLIED WARRANTY OF MERCHANTABILITY, TITLE, FITNESS FOR A PARTICULAR PURPOSE OR NON-INFRINGEMENT OF INTELLECTUAL PROPERTY RIGHTS. IN NO EVENT WILL ADI AND ITS LICENSORS BE LIABLE FOR ANY INCIDENTAL, SPECIAL, INDIRECT, OR CONSEQUENTIAL DAMAGES RESULTING FROM CUSTOMER'S POSSESSION OR USE OF THE EVALUATION BOARD, INCLUDING BUT NOT LIMITED TO LOST PROFITS, DELAY COSTS, LABOR COSTS OR LOSS OF GOODWILL. ADI'S TOTAL LIABILITY FROM ANY AND ALL CAUSES SHALL BE LIMITED TO THE AMOUNT OF ONE HUNDRED US DOLLARS (\$100.00). EXPORT. Customer agrees that it will not directly or indirectly export the Evaluation Board to another country, and that it will comply with all applicable United States federal laws and regulations relating to exports. GOVERNING LAW. This Agreement shall be governed by and construed in accordance with the substantive laws of the Commonwealth of Massachusetts (excluding conflict of law rules). Any legal action regarding this Agreement will be heard in the state or federal courts having jurisdiction in Suffolk County, Massachusetts, and Customer hereby submits to the personal jurisdiction and venue of such courts. The United Nations Convention on Contracts for the International Sale of Goods shall not apply to this Agreement and is expressly disclaimed.

