

L6480 Discovery: development tool to explore L6480 motor controller

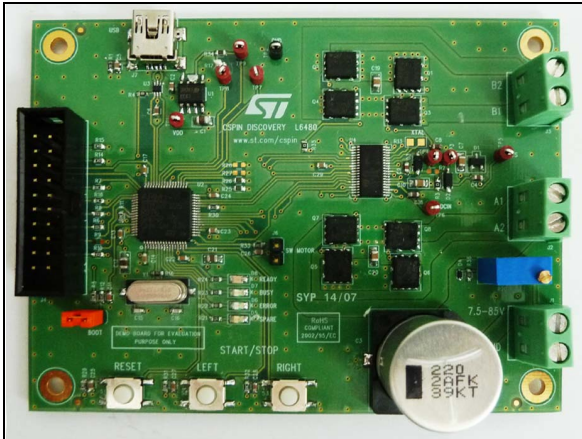

Data brief

Features

- Voltage range from 10.5 V to 85 V
- Phase current up to 7.8 A_{r.m.s}
- Footprint for external resonator or crystal
- Switch motor input control
- Keys start/left - stop/right - reset
- Ready, busy, error LED indicators
- Spare LED indicators for specific design
- Sensorless stall detection
- Compatible with SPIN family evaluation tool
- Autonomous board due to an embedded firmware
- Up to 1/128 microstepping
- Programmable non dissipative overcurrent
- Overtemperature protection

Description

The L6480 Discovery is a low cost development tool to explore the L6480 motor controller.

The EVAL6480H-DISC is an ideal starter kit for both beginners and experienced users, it is autonomous and can be used with a software interface, or it can be used with custom firmware thanks to the embedded microcontroller.

Through the available GUI a user can easily set the full configuration of application parameters. The “Plug and Play” tool offers high motor control flexibility thanks to the wide operating voltage range from 10.5 V to 85 V and the current capability up to 7.8 A_{r.m.s}. It is equipped with LED indicators for a specific ready, busy, and error warning.

Board description

Table 1. Electrical specifications

Parameter	Value
Supply voltage (V_S)	10.5 to 85 V
Maximum output current (each phase)	7.8 A _{r.m.s}
Internal voltage regulator (V_{SREG})	10.5 to 85 V
Gate driver supply voltage (V_{CC})	7.5 or 15 V
Logic and supply interface voltage ($V_{DD} - V_{REG}$)	3.3 V
Low level logic inputs voltage	0 V
High level logic input voltage	V_{DD}
Stepping	Up to 1/128 microstepping
Operating temperature	0 to 85 °C

Figure 1. Jumpers and connectors location

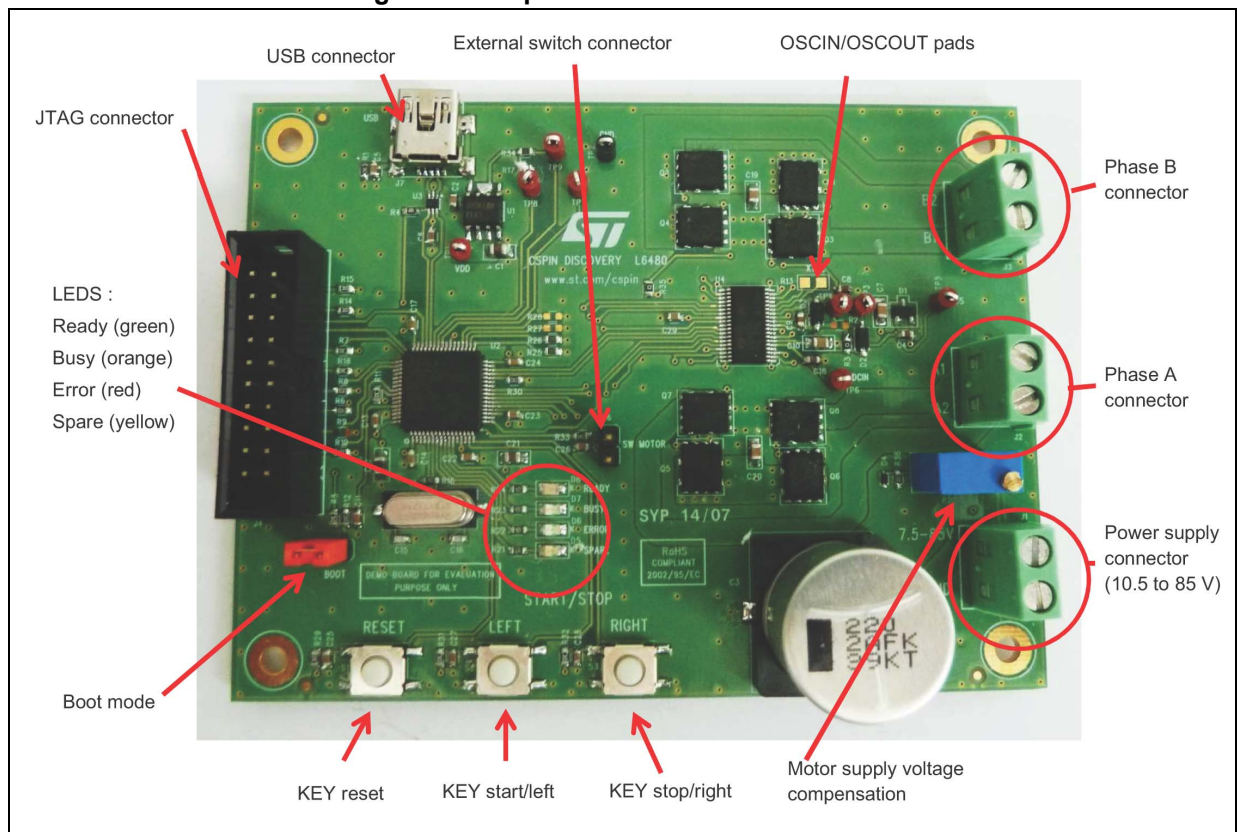

Table 2. Jumpers and connectors

Name	Function
J1	Motor supply voltage
J2	Bridge A output
J3	Bridge B output
J4	Debug JTAG function
J5	Boot mode
J6	External switch input
J7	USB function
R13	OSCIN and OUSCOUT pins
TP1	V _{DD} - logic supply voltage
TP2	GND - ground test point
TP3	V _{SREG} driver supply
TP4	V _{CC} driver supply
TP5	V _S - motor supply voltage
TP6	Motor supply voltage compensation
TP7	UART CK - debug test point
TP8	UART RX - debug test point
TP9	UART TX - debug test point

Table 3. JTAG connector pinout (J4)

Name	Type	Function
1 - 2	Supply	EXT_VDD
3	Digital I/O	External RESET
5	Digital I/O	INPUT (TDI)
7	Digital I/O	Mode select (TMS)
9	Digital I/O	Clock (TCK)
13	Digital I/O	OUTPUT (TDO)
15	Digital I/O	Internal RESET
11 - 17 - 19	Digital I/O	Pull down
4 - 6 - 8 - 10 - 12 - 14 - 16 - 18 - 20	Ground	Ground

Figure 2. Schematic (microcontroller control part)

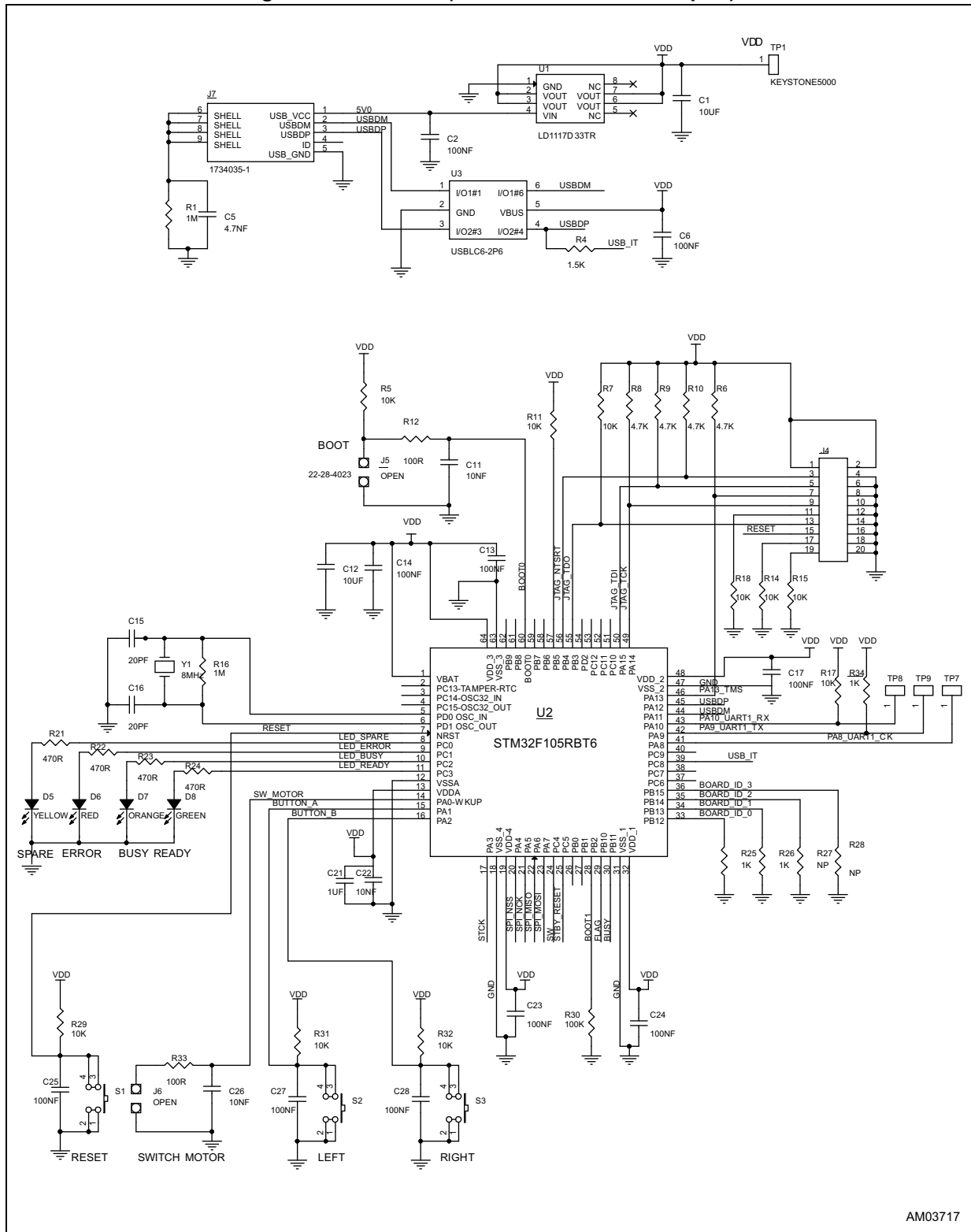

AM03717



Figure 3. Schematic (motion control part)

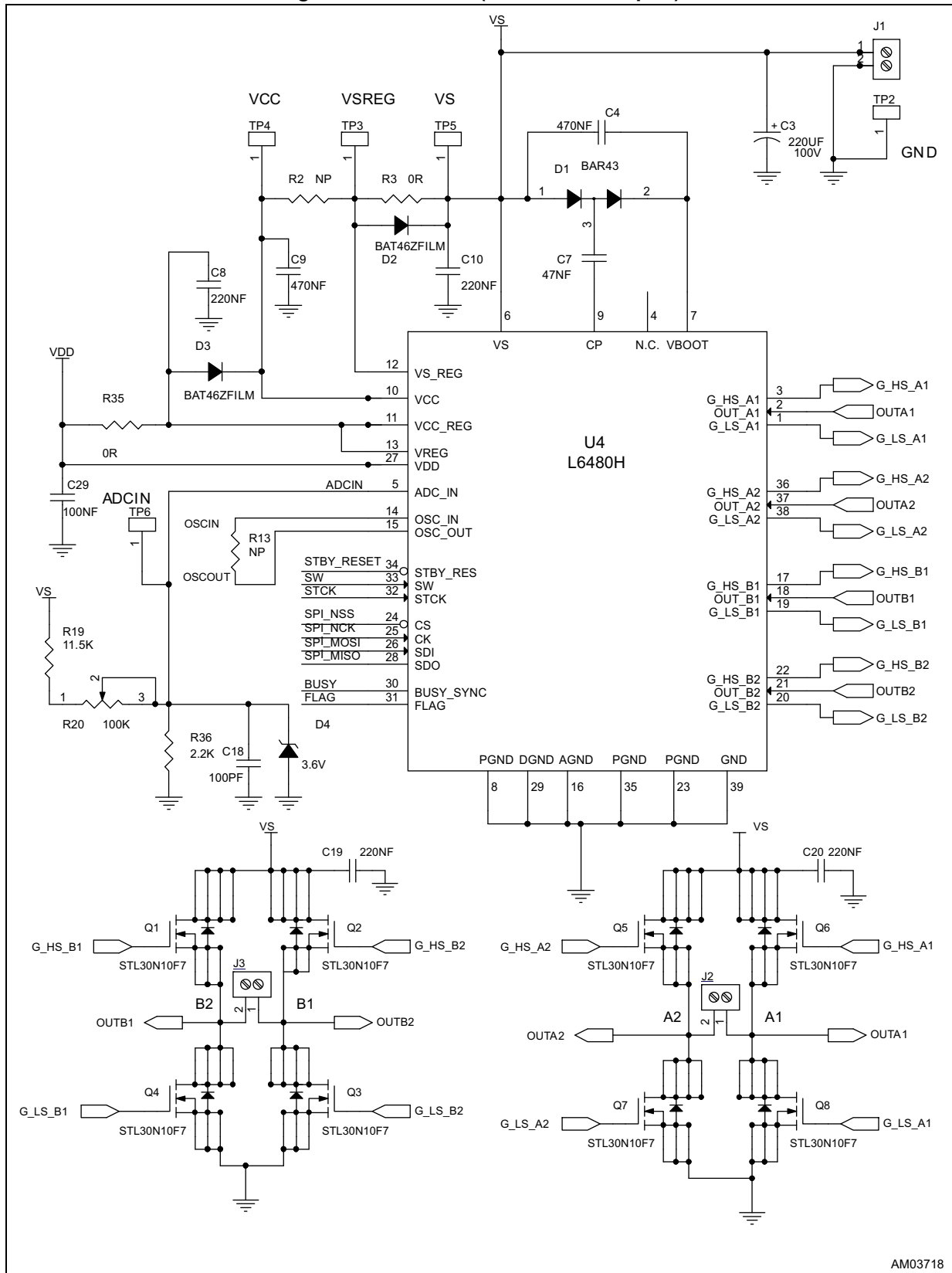

Table 4. Bill of material

Item	Qty.	Reference	Value	Package
C1, C12	2	CAP. CER. 10 μ F 10 V X7R 0805	10 μ F	0805
C2, C6, C13, C14, C17, C23-C25, C27-C29	11	CAP. CER. 100 nF 50 V X7R 0603	100 nF	0603
C3	1	CAP. ELEC. 220 μ F 100 V	220 μ F	CAPES-R18H17
C4, C9	2	CAP. CER. 470 nF 25 V X7R 0603	470 nF	0603
C5	1	CAP. CER. 4.7nF 50 V X7R 0603	4.7 nF	0603
C7	1	CAP. CER. 47 nF 100 V X7R/X7S 0805	47 nF	0805
C8	1	CAP. CER. 220 nF 35 V X7R 0603	220 nF	0603
C10, C19, C20	3	CAP. CER. 220 nF 100 V X7R 0805	220 nF	0805
C11, C22, C26	3	CAP. CER. 10 nF 50 V X7R 0603	10 nF	0603
C15, C16	2	CAP. CER. 20 pF 50 V COG 0603	20 pF	0603
C18	1	CAP. CER. 100 pF 50 V COG 0603	100 pF	0603
C21	1	CAP. CER. 1 μ F 10 V X7R 0805	1 μ F	0805
D1	1	Double diode - high speed switching diode	BAR43	SOT23
D2, D3	2	Diode Schottky 150 MA	BAT46ZFILM	SOD 123
D4	1	Zener regulator	3.6 V	SOD 523
D5	1	LED yellow - 0805 -6 mcd - 588 nm	Yellow	0805
D6	1	LED red - 0805 -2 mcd - 621 nm	Red	0805
D7	1	LED orange - 0805 -2 mcd - 602 nm	Orange	0805
D8	1	LED green - 0805 -6 mcd - 569 nm	Green	0805
FIX1 - FIX4	4	Hole		Diam. 3 mn
J1 - J3	3	Screw connector 2 poles MKDSN 1.5/2-5.08	MKDSN1.5/2-5.08	MKDSN1.5/2-5.08
J4	1	JTAG con. - straight- 10 x 2 - 180 M	CON. - STRAIGHT - 10 x 2 - 180 M	CON. - FLAT - 10 x 2 - 180 M
J5 J6	2	JUMP254P-M-2	OPEN	2.54 mn
J7	1	USB_B_MINI_AMP_1734035-1	CN-USB	CMS mini USB
MIRE1 - MIRE3	3	OPTICAL_TARGET	OPTICAL_TARGET	Diam. 1 mn
Q1 - Q8	8	N-channel 100 V, 27 m Ω , 8 A STripFET™ VII DeepGATE™ Power MOSFET in PowerFLAT™ 5 x 6 package	STL30N10F7	PowerFLAT 5 x 6
R1, R16	2	Res. 1 M Ω M 1/10 W 5% 0603 SMD	1 M Ω	0603
R2, R27, R28	3	Res. NP 0603	NP	0603
R3, R35	2	Res. 0.0 Ω 5% 1/1 0W 0603	0 Ω	0603

Table 4. Bill of material (continued)

Item	Qty.	Reference	Value	Package
R4	1	Res. 1.5 K Ω 1/10 W 5% 0603 SMD	1.5 K Ω	0603
R5, R7, R11, R14, R15, R17, R18, R29, R31, R32	10	Res. 10 K Ω 5% 1/10 W 0603 SMD	10 K Ω	0603
R6, R8 - R10	4	Res. 4.7 K Ω 5% 1/10 W 0603 SMD	4.7 K Ω	0603
R12, R33	2	Res. 100 Ω 5% 1/10 W	100 Ω	0603
R13	1	Res. NP 0805	NP	0805
R19	1	Res. 11.5 K Ω 1% 1/10 W 0603	11.5 K Ω	0603
R20	1	Trimmer 100 K Ω 100 x 50 x 110 64 W	100 K Ω	Trimm. 100 x 50 x 110
R21 - R24	4	Res. 470 Ω 5% 1/10 W 0603	470 Ω	0603
R25, R26, R34	3	Res. 1 K Ω 5% 1/10 W 0603 SMD	1 K Ω	0603
R30	1	Res. 100 K Ω 5% 1/10 W 0603 SMD	100 K Ω	0603
R36	1	Res. 2.2 K Ω 1/10 W 5% 0603 SMD	2.2 K Ω	0603
S1 - S3	3	Switch button SMD	EVQQ2D03W	CMS 6.5 x 6 x 3.1
TP1, TP3 - TP9	8	Test point red	KEYSTONE-5000	TH
TP2	1	Test point black	KEYSTONE-5001	TH
U1	1	IC reg. 1300MA LN 3.3 V	LD1117D33TR	SO8
U2	1	IC, MCU, RISC, 72 MHz, 3.6 V, 32-bit, 64-pin, LQFP	STM32F105RBT6	LQFP64 10 x 10
U3	1	USBLC6-2P6 - TVS USB2	USBLC6-2P6	SOT 666
U4	1	L6480 motor controller	L6480H	HTSSOP38
Y1	1	XTAL 8 MHz-30 PPM-20 pF	8 MHz	HC49/US-SM

Figure 4. Layout (top layer)

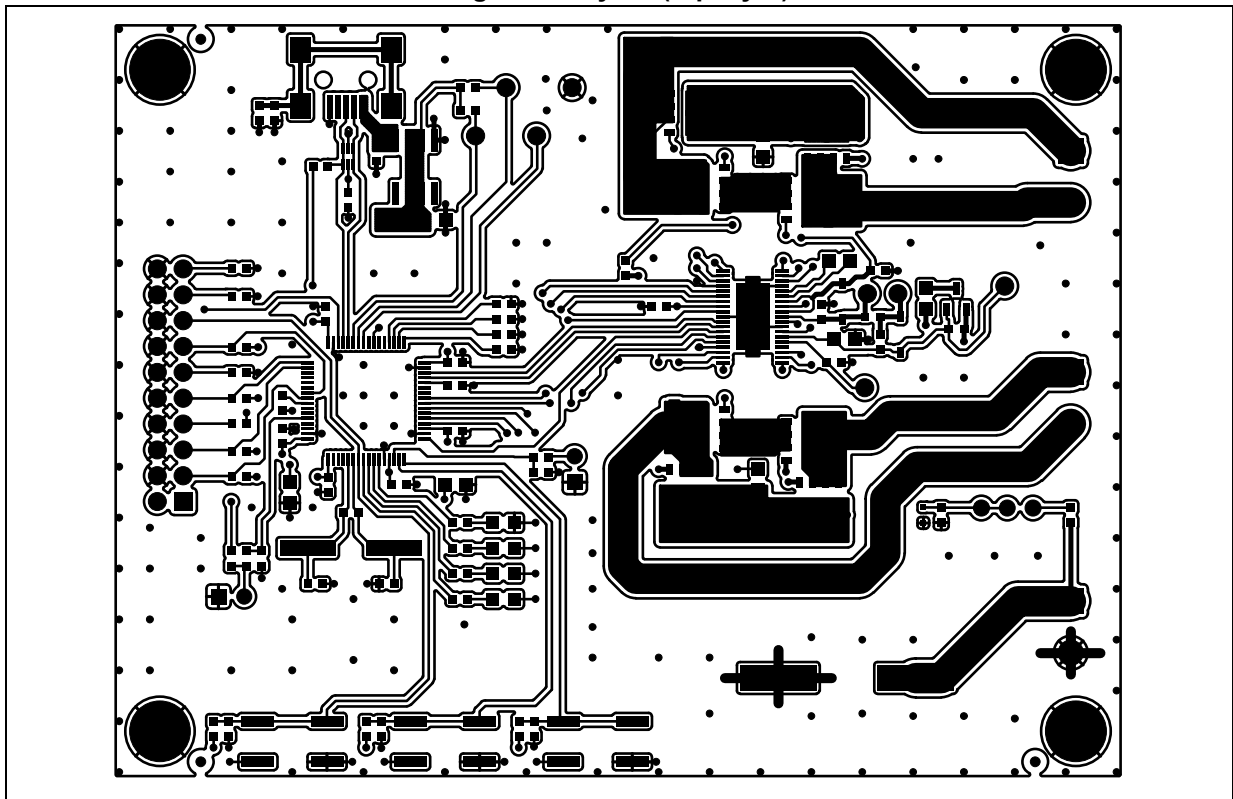
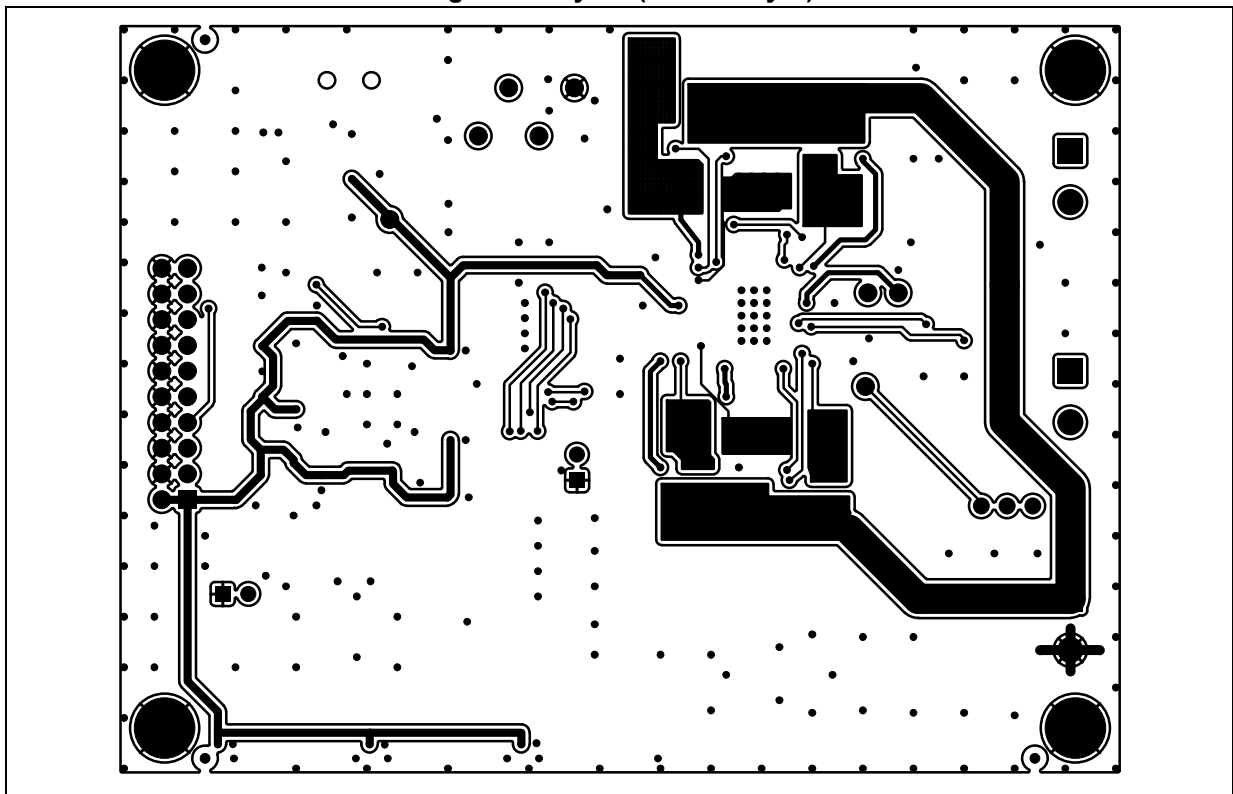

Figure 5. Layout (bottom layer)



Revision history

Table 5. Document revision history

Date	Revision	Changes
23-Apr-2014	1	Initial release.
05-Mar-2015	2	Updated main title <i>on page 1</i> , <i>Section : Description on page 1</i> and <i>Table 4 on page 6</i> [replaced cSPIN by L6480 (motor controller)]. Removed Figure 4. Layout (silk screen) from page 8.

IMPORTANT NOTICE – PLEASE READ CAREFULLY

STMicroelectronics NV and its subsidiaries ("ST") reserve the right to make changes, corrections, enhancements, modifications, and improvements to ST products and/or to this document at any time without notice. Purchasers should obtain the latest relevant information on ST products before placing orders. ST products are sold pursuant to ST's terms and conditions of sale in place at the time of order acknowledgement.

Purchasers are solely responsible for the choice, selection, and use of ST products and ST assumes no liability for application assistance or the design of Purchasers' products.

No license, express or implied, to any intellectual property right is granted by ST herein.

Resale of ST products with provisions different from the information set forth herein shall void any warranty granted by ST for such product.

ST and the ST logo are trademarks of ST. All other product or service names are the property of their respective owners.

Information in this document supersedes and replaces information previously supplied in any prior versions of this document.

© 2015 STMicroelectronics – All rights reserved