

Battery management system module based on on the L9963E and L9963T

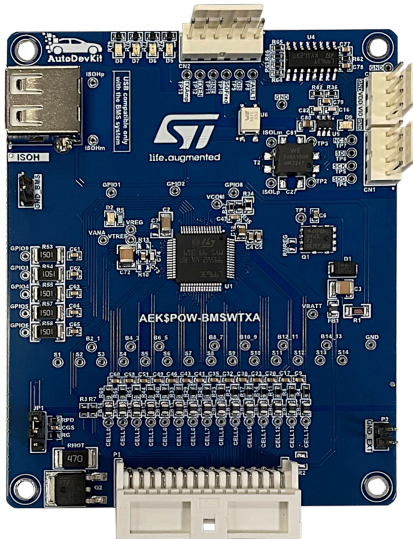

Features

- Hosts the L9963E AEC-Q100 qualified automotive multicell battery monitoring and balancing IC
- Hosts the L9963T AEC-Q100 qualified automotive general purpose SPI to isolated SPI bidirectional transceiver
- Voltage monitoring of every single cell and of the entire battery node
- Current sensing of the entire battery node
- 5 GPIOs to connect temperature sensors as NTCs
- CN1 connector that allows establishing communication with an MCU board via SPI
- CN2 connector that interfaces directly to an MCU board for control and diagnostic functions
- Passive balancing
- Compact size: 100 mm x 76 mm
- Included in the [AutoDevKit](#) ecosystem

Description

The **AEK-POW-BMSWTX** is a battery management system (BMS) evaluation board that manages from 4 to 14 battery cells.

The main advantage of this evaluation board is ensuring isolated connection to an external MCU, thanks to the embedded transceiver.

The board is based on the **L9963E** Li-ion battery monitoring and protection chip for high-reliability automotive applications and the **L9963T** general purpose SPI to isolated SPI bidirectional transceiver.

The main activity of the **L9963E** is monitoring the cells and battery node status through stack voltage measurement, cell voltage measurement, temperature measurement, and coulomb counting.

Measurement and diagnostic tasks can be executed either on demand or periodically, with a programmable cycle interval.

Measurement data are available for an external microcontroller to perform charge balancing and to compute the state of charge (SOC) and the state of health (SOH).

The **L9963T** general purpose SPI to isolated SPI bidirectional transceiver can transfer communication data incoming from a classical 4-wire based SPI interface to a 2-wire isolated interface (and vice versa). In our board, the transceiver is configured as a slave.

The **AEK-POW-BMSWTX** provides an elaborate monitoring network to sense the voltage of each cell. It is possible to sense the current of the entire battery pack. This sensing allows elaborating the SOC of each battery cell and, consequently, the state of charge of all battery packs.

The SOC allows assessing the remaining battery capacity, which equates to the remaining driving range.

Product summary

Battery management system module based on the L9963E and L9963T	AEK-POW-BMSWTX
Automotive chip for battery management applications with daisy chain up to 31 devices	L9963E
Automotive general purpose SPI to isolated SPI transceiver	L9963T
Battery management system module based on L9963E	AEK-POW-BMS63EN
SPI to isolated SPI dongle based on the L9963T transceiver	AEK-COM-ISOSPI1
MCU discovery board for SPC5 Chorus 4M automotive microcontroller with CAN transceivers	AEK-MCU-C4MLIT1

Product summary	
STSW AutoDevKit Embedded Software	AUTODEVKIT SW
Applications	Battery Management Systems E-mobility Home battery accumulators

For maintenance reasons, it is important to monitor the SOC estimation over time. According to our algorithm for the SOC calculation, the more the SOC differs from its nominal value (that is, its value when the batteries are new), the more a cell of the battery pack risks overdischarging. Thus, the SOC evolution over time allows asserting the state of health (SOH) of a cell or a battery pack to spot early indications that a cell is at risk of overdischarge or overcharging.

The SOC of a battery cell is required to maintain its safe operation and duration during charge, discharge, and storage. However, SOC cannot be measured directly and is estimated from other measurements and known parameters (such as characterization curves or look-up tables). This information on the battery cells is necessary to determine how the voltage varies according to the current, the temperature, etc., on the basis of the battery chemical composition and production lot used.

Thanks to the partnership with About:Energy, it is possible to access to various battery data models.

In the AutoDevKit ecosystem software package, we created an example to elaborate SOC and SOH, using Li-ion batteries. Battery packs may have different SOC, and balancing is necessary to bring them all to the same charge level.

After detecting the lowest charge in the battery pack, all the other battery nodes are discharged to reach its level. The demo explains how to activate the internal MOSFETs of the [L9963E](#), which short-circuit the cell on an external dissipation resistor (resistors are already mounted on the board) to discharge it.

Passive cell balancing can be performed either via the [L9963E](#) internal MOSFETs or via external MOSFETs. The controller can either manually control the balancing drivers or start a balancing task with a fixed duration. In the second case, the balancing may be programmed to continue even when the IC enters a low power mode called silent balancing, to avoid unnecessary current absorption from the battery pack. The balancing function is necessary to lengthen the battery capacity and its duration.

Different MCUs can be used. In our demos, we used the [AEK-MCU-C4MLIT1](#), and other ASIL-B and ASIL-D microcontrollers of the SPC58 chorus family.

1 Block diagram

Figure 1. Block diagram

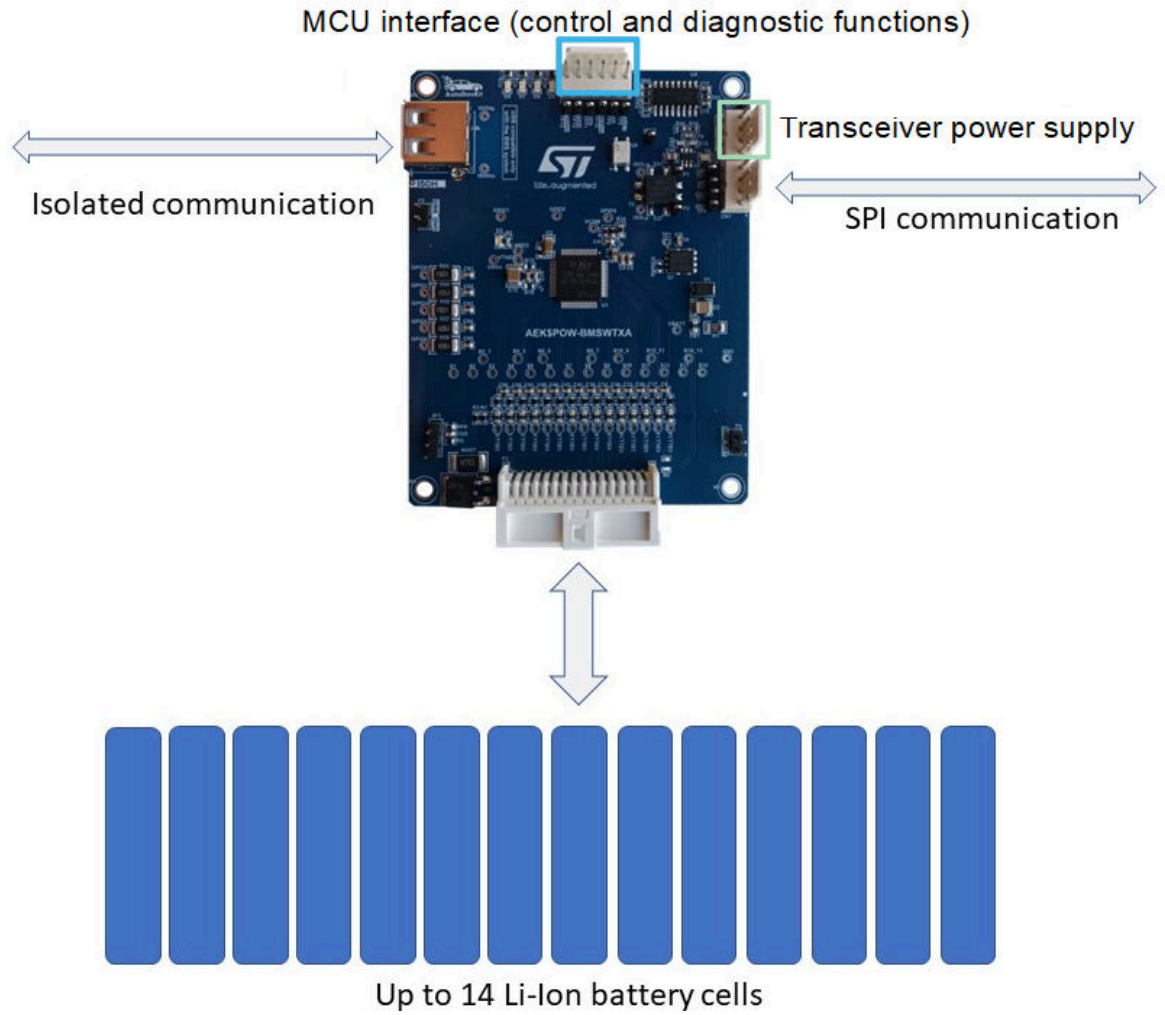

2 AEK-POW-BMSWTX schematic diagrams

Figure 2. AEK-POW-BMSWTX circuit schematic (1 of 2)

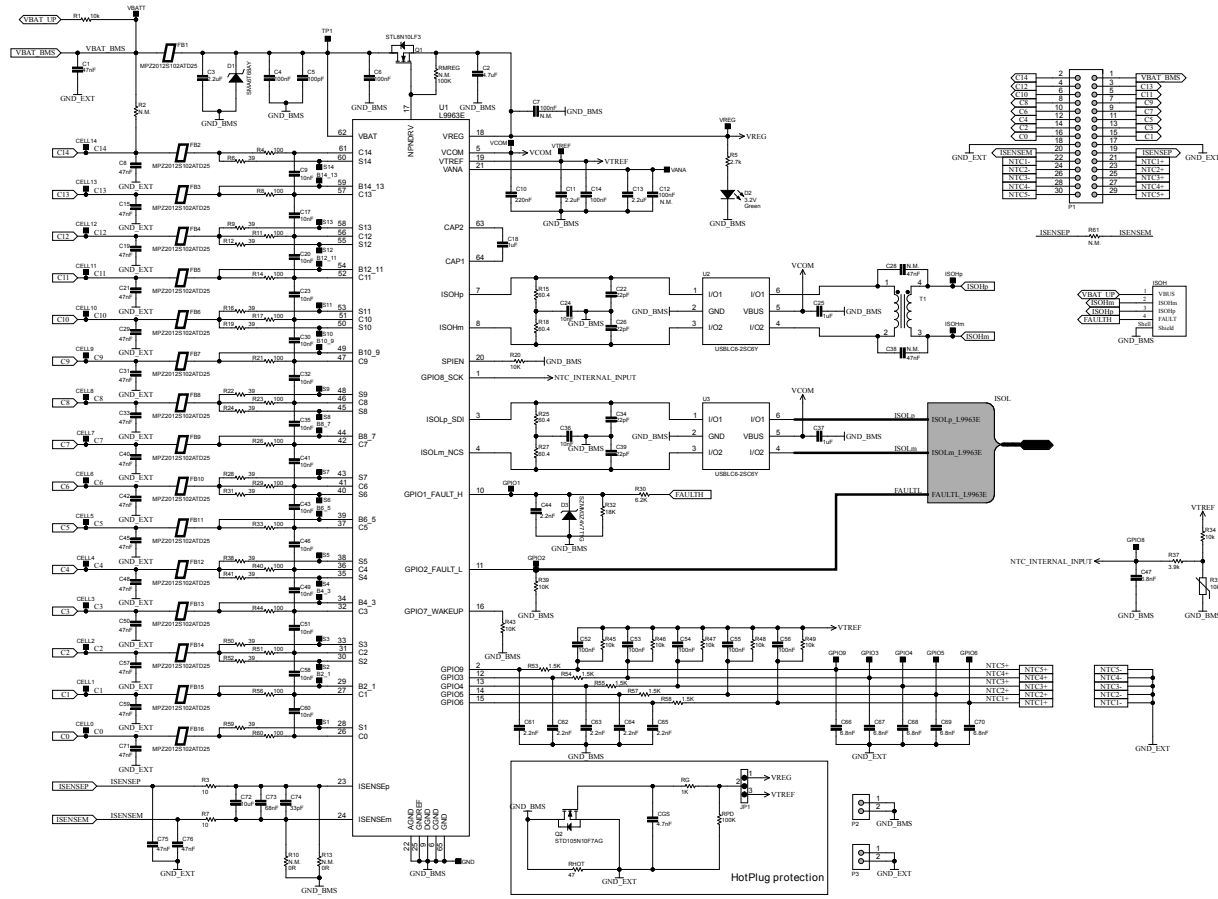

3 AEK-POW-BMSWTX Board versions

Table 1. AEK-POW-BMSWTX versions

Finished good	Schematic diagrams	Bill of materials
AEK\$POW-BMSWTXA ⁽¹⁾	AEK\$POW-BMSWTXA schematic diagrams	AEK\$POW-BMSWTXA bill of materials

1. This code identifies the AEK-POW-BMSWTX evaluation board first version. It is printed on the board PCB.

Revision history

Table 2. Document revision history

Date	Revision	Changes
08-Aug-2024	1	Initial release.

IMPORTANT NOTICE – READ CAREFULLY

STMicroelectronics NV and its subsidiaries (“ST”) reserve the right to make changes, corrections, enhancements, modifications, and improvements to ST products and/or to this document at any time without notice. Purchasers should obtain the latest relevant information on ST products before placing orders. ST products are sold pursuant to ST’s terms and conditions of sale in place at the time of order acknowledgment.

Purchasers are solely responsible for the choice, selection, and use of ST products and ST assumes no liability for application assistance or the design of purchasers’ products.

No license, express or implied, to any intellectual property right is granted by ST herein.

Resale of ST products with provisions different from the information set forth herein shall void any warranty granted by ST for such product.

ST and the ST logo are trademarks of ST. For additional information about ST trademarks, refer to www.st.com/trademarks. All other product or service names are the property of their respective owners.

Information in this document supersedes and replaces information previously supplied in any prior versions of this document.

© 2024 STMicroelectronics – All rights reserved