

# EVAL-AD2437B1MZ Manual

Revision 2.1 , August 2023

Part Number  
EVAL-AD2437B1MZ

Analog Devices, Inc.  
One Technology Way  
Norwood, MA 02062-9106



# Copyright Information

© 2023 Analog Devices, Inc., ALL RIGHTS RESERVED. This document may not be reproduced in any form without prior, express written consent from Analog Devices, Inc.

## Disclaimer

Analog Devices, Inc. reserves the right to change this product without prior notice. Information furnished by Analog Devices is believed to be accurate and reliable. However, no responsibility is assumed by Analog Devices for its use; nor for any infringement of patents or other rights of third parties which may result from its use. No license is granted by implication or otherwise under the patent rights of Analog Devices, Inc.

## Trademark and Service Mark Notice

The Analog Devices logo, Blackfin, SHARC, A<sup>2</sup>B, SigmaDSP, SigmaStudio+, and EngineerZone are registered trademarks of Analog Devices, Inc.

All other brand and product names are trademarks or service marks of their respective owners.

# Regulatory Compliance

The *EVAL-AD2437B1MZ* evaluation board is designed to be used solely in a laboratory environment. The board is not intended for use as a consumer-end product or as a portion of a consumer-end product. The board is an open system design, which does not include a shielded enclosure and, therefore, may cause interference to other electrical devices in close proximity. This board should not be used in or near any medical equipment or RF devices.

The *EVAL-AD2437B1MZ* evaluation board contains ESD (electrostatic discharge) sensitive devices. Electrostatic charges readily accumulate on the human body and equipment and can discharge without detection. Permanent damage may occur on devices subjected to high-energy discharges. Proper ESD precautions are recommended to avoid performance degradation or loss of functionality. Store unused boards in the protective shipping package.



# Contents

## Preface

Purpose of This Manual.....	1-2
Manual Contents.....	1-2
Technical Support.....	1-3
Supported Integrated Circuit.....	1-3
Supported Tools.....	1-3
Product Information.....	1-3
Analog Devices Website.....	1-3
EngineerZone.....	1-4

## Using the Board

Product Overview.....	2-1
Package Contents.....	2-2
Default Configuration.....	2-2
Reference Design Information.....	2-3
AD2437 - Audio Bus A <sup>2</sup> B Transceiver.....	2-3
ADA4661 -18 V, Precision, 725 $\mu$ A, 4 MHz, CMOS RRIO Operational Amplifier.....	2-4
ADAU1701 SigmaDSP 28-/56-Bit Audio Processor with Two ADCs and Four DACs.....	2-4
ADP2360 - 50 mA, 60 V, High Efficiency Buck Regulator.....	2-5
BD28623MUV - Class D Speaker Amplifier.....	2-5
IM69D120 High Performance Digital MEMS Microphone.....	2-5
LT3502/LT3502A - 1.1MHz/2.2MHz, 500mA Step-Down Regulators in 2mm $\times$ 2mm DFN and MS10 ....	2-5
M24512-RMN6TP - Automotive 512-Kbit Serial I <sup>2</sup> C EEPROM with 1MHz clock.....	2-6

## Hardware Reference

Connectors.....	3-1
Stereo Connectors( TP5-TP8 ).....	3-2
Audio I2S Connector ( P1).....	3-3

<b>SigmaStudio+ ( P2)</b> .....	3-3
<b>Multipurpose pins( P5 )</b> .....	3-3
<b>ADC Input Connector( P7 )</b> .....	3-3
<b>DAC Output Connector( P20 )</b> .....	3-3
<b>A<sup>2</sup>B ( P27 and P21)</b> .....	3-3
<b>Jumpers</b> .....	3-4
<b>AD2437 SIO0 Routing ( P4)</b> .....	3-4
<b>AD2437 SIO1 Routing ( P23)</b> .....	3-5
<b>AD2437 BCLK Select ( P16)</b> .....	3-5
<b>ADAU1701 I2C Bus Switch ( P18 and P22)</b> .....	3-5
<b>LEDs</b> .....	3-5
<b>A<sup>2</sup>B Interrupt ( DS2)</b> .....	3-6
<b>Power Status Indicator ( DS1, DS3, DS5)</b> .....	3-6
<b>I2C Bus Switch ( DS4)</b> .....	3-7
<b>BD28623MUV Error Status ( DS6)</b> .....	3-7

# 1 Preface

Thank you for purchasing the Analog Devices, Inc. *EVAL-AD2437B1MZ* evaluation board.

The *EVAL-AD2437B1MZ* is an evaluation board to evaluate various peripherals of AD2437 A<sup>2</sup>B (Audio Bus) transceiver. Refer datasheet/manual to get more details about AD2437.

The *EVAL-AD2437B1MZ* is configured to be a Bus-Powered Sub (BPS) node. The *EVAL-AD2437B1MZ* can be connected to a Main Node, Local-Powered Sub (LPS) or a Bus-Powered Sub (BPS) Node. These evaluation boards are intended to be used with the SigmaStudio+ graphical development tool.

Block Diagram of Evaluation Board:

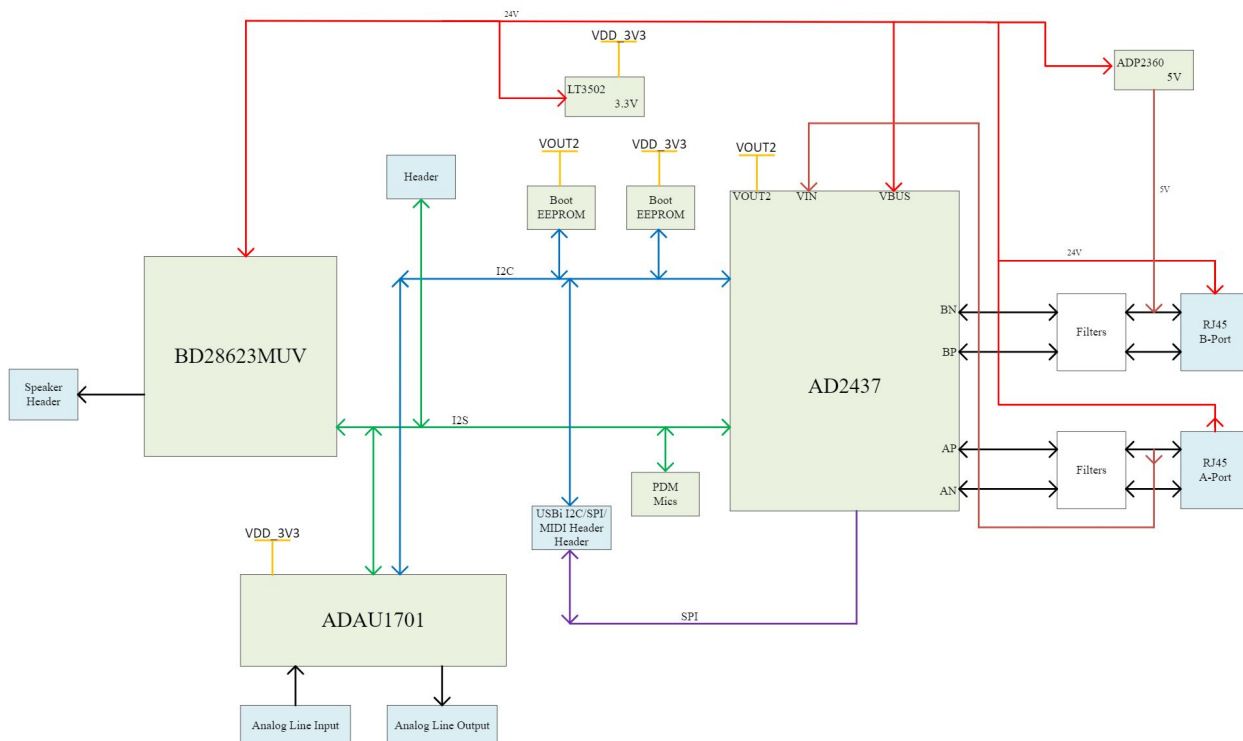

A PC host controls the AD2437 A<sup>2</sup>B main transceiver I2C/SPI signals over the USB-to- I2C/SPI bridge, the USBi(EVAL-ADUSB2EB). This allows the PC to directly discover and control an A<sup>2</sup>B network as well as to read back registers and monitor performance.

The SigmaStudio+<sup>®</sup> graphical development tool is the programming, development, and tuning software for the SigmaDSP, A<sup>2</sup>B, and Sharc processors. Familiar audio processing blocks can be wired together as in a schematic, and the compiler generates DSP-ready code and a control surface for setting and tuning parameters. This tool allows engineers with no DSP code writing experience to easily implement a DSP into their design and yet is still powerful enough to satisfy the demands of experienced DSP designers. SigmaStudio+ links with both Analog Devices evaluation boards and production designs to provide full in-circuit real-time IC control.

SigmaStudio+ includes an extensive library of algorithms to perform audio processing such as filtering, mixing, and dynamics processing, as well as basic low-level DSP functions and control blocks. Advanced record-side processing algorithms such as Enhanced Stereo Capture and wind noise detection are included in the standard libraries. Plug-in algorithms from Analog Devices and 3rd party partners can be added to SigmaStudio+'s drag-and-drop library.

Along with its graphical DSP signal flow development, SigmaStudio+ also includes other features to speed up the design cycle from product concept to release. SigmaStudio+ includes tools for intuitively setting control registers, calculating tables of filter coefficients, visualizing filter magnitude and phase responses, generating C header files, and sequencing a series of controls to ease your transition from SigmaStudio+ to system implementation on your microcontroller.

## Purpose of This Manual

This manual provides instructions for installing the product hardware (board). This manual describes the operation and configuration of board components and provides guidelines for running code on the board.

## Manual Contents

The manual consists of:

- *Using the board*

Provides basic board information.

- *Hardware Reference*

Provides information about the hardware aspects of the board.

- *Bill of Materials*

A companion file in PDF format that lists all of the components used on the board is available on the website at <https://www.analog.com/en/design-center/evaluation-hardware-and-software/evaluation-boards-kits/EVAL-AD2437B1MZ.html>.

- *Schematic*

A companion file in PDF format documenting all of the circuits used on the board is available on the website at <https://www.analog.com/en/design-center/evaluation-hardware-and-software/evaluation-boards-kits/EVAL-AD2437B1MZ.html>.

## Technical Support

You can reach Analog Devices technical support in one of the following ways:

- Post your questions in the A<sup>2</sup>B support community at EngineerZone<sup>®</sup>:  
<http://ez.analog.com/a2b/>
- Submit your questions to technical support directly at:  
<http://www.analog.com/support>
- E-mail your questions about A<sup>2</sup>B transceiver applications and SigmaStudio+ to:  
[A2B.support@analog.com](mailto:A2B.support@analog.com)
- Contact your Analog Devices sales office or authorized distributor. Locate one at:  
<http://www.analog.com/adi-sales>

## Supported Integrated Circuit

This evaluation system supports the Analog Devices AD2437 IC.

## Supported Tools

Information about SigmaStudio+ and the A<sup>2</sup>B software plug-in for the *EVAL-AD2437B1MZ* evaluation board is available at: [www.analog.com/SigmaStudio+](http://www.analog.com/SigmaStudio+).

## Product Information

Information about the AD2437 product family is available at: [www.analog.com/A2B](http://www.analog.com/A2B)

## Analog Devices Website

The Analog Devices website, <http://www.analog.com>, provides information about a broad range of products - analog integrated circuits, amplifiers, converters, transceivers, and digital signal processors.

Also note, [MyAnalog.com](http://MyAnalog.com) is a free feature of the Analog Devices website that allows customization of a web page to display only the latest information about products you are interested in. You can choose to receive weekly e-mail notifications containing updates to the web pages that meet your interests, including documentation errata against all manuals. [MyAnalog.com](http://MyAnalog.com) provides access to books, application notes, data sheets, code examples, and more.

Visit [MyAnalog.com](http://MyAnalog.com) to sign up. If you are a registered user, just log on. Your user name is your e-mail address.

## EngineerZone

EngineerZone is a technical support forum from Analog Devices, Inc. It allows you direct access to ADI technical support engineers. You can search FAQs and technical information to get quick answers to your embedded processing and DSP design questions.

Use EngineerZone to connect with other DSP developers who face similar design challenges. You can also use this open forum to share knowledge and collaborate with the ADI support team and your peers. Visit <http://ez.analog.com> to sign up.



## 2 Using the Board

This chapter provides information on the major components and peripherals on the board, along with instructions for installing and setting up the emulation software.

### Product Overview

The board features:

- Analog Devices AD2437 - Audio Bus Transceiver
- Analog Devices [ADA4661](#) -18 V, Precision, 725  $\mu$ A, 4 MHz, CMOS RRIO Operational Amplifier
- Analog Devices [ADP2360](#) - 50 mA, 60 V, High Efficiency Buck Regulator
- Analog Devices [LT3502/LT3502A](#) - 1.1MHz/2.2MHz, 500mA Step-Down Regulators in 2mm  $\times$  2mm DFN and MS10
- Microchip Technology 25AA256 - 256K SPI Bus Serial EEPROM
- Infineon [IM69D120](#) High Performance Digital MEMS Microphone
- Mouser [M24512-RMN6TP](#) - Automotive 512-Kbit Serial I<sup>2</sup>C EEPROM with 1MHz clock
- Audio
  - Analog Devices [ADAU1701](#) SigmaDSP 28-/56-Bit Audio Processor with Two ADCs and Four DACs
  - [BD28623MUV](#) - Class D Speaker Amplifier
  - Four Stereo MEMS Microphones
  - EEPROM
  - Three 3.5mm audio jacks, One input, Two output
- A<sup>2</sup>B
  - Two RJ45 Shielded Terminals
- LEDs
  - Six LEDs : 3.3V, 5V, Power, Error, IRQ, Bus Switch

## Package Contents

Your *EVAL-AD2437B1MZ* package contains the following items.

- *EVAL-AD2437B1MZ* board
- 1m RJ45 Cable
- A<sup>2</sup>B Software - Online Request Documentation

Contact the vendor where you purchased your *EVAL-AD2437B1MZ* evaluation board or contact Analog Devices, Inc. if any item is missing.

## Default Configuration

The *Default Hardware Setup* figure shows the default settings for jumpers and switches and the location of the jumpers, switches, connectors, and LEDs. Confirm that your board is in the default configuration before using the board.

Default Config of Sub Node

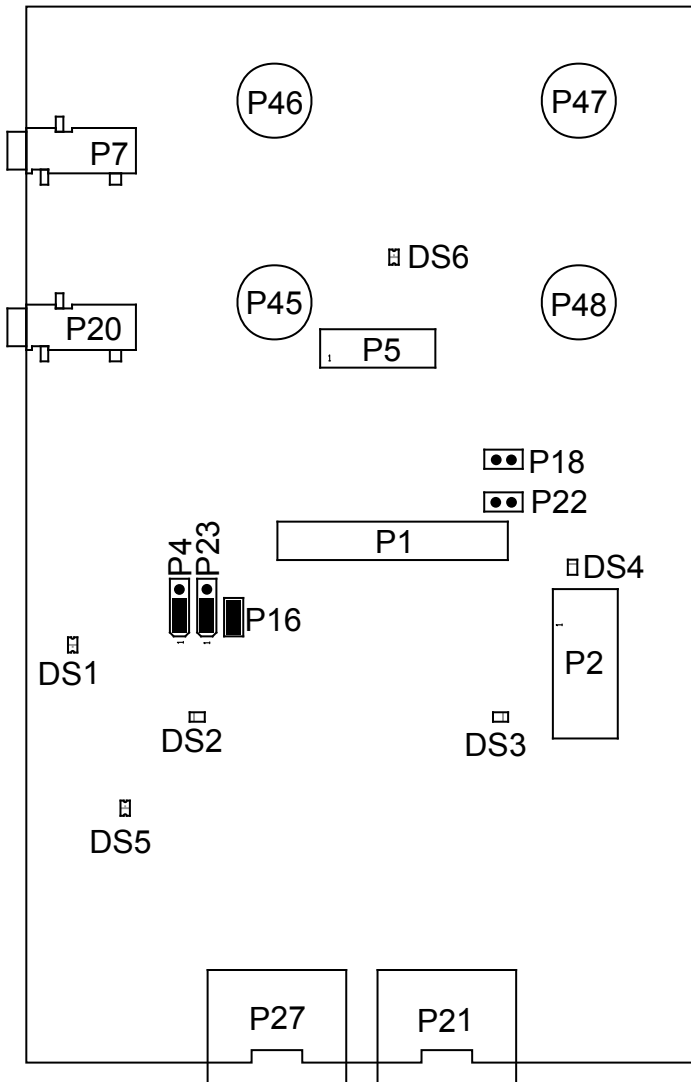

Figure 2-1: Default Hardware Setup

## Reference Design Information

A reference design info package is available for download on the Analog Devices Web site. The package provides information on the schematic design, layout, fabrication, and assembly of the board.

The information can be found at:

<https://www.analog.com/en/design-center/evaluation-hardware-and-software/evaluation-boards-kits/EVAL-AD2437B1MZ.html>

## AD2437 - Audio Bus A<sup>2</sup>B Transceiver

The [AD2437](#) provides a multi-channel, I<sup>2</sup>S/TDM link over distances of up to 30 m between nodes. It embeds bi-directional synchronous pulse-code modulation (PCM) data (for example, digital audio), clock, and synchronization signals onto a single differential wire pair. A<sup>2</sup>B supports a direct point to point connection and allows multiple, daisy-chained nodes at different locations to contribute and/or consume time division multiplexed channel content.

A<sup>2</sup>B is a single-main, multiple-sub system where the transceiver at the host controller is the main node and generates clock, synchronization, and framing for all sub nodes. The main A<sup>2</sup>B device is programmable over a control bus (I<sup>2</sup>C and SPI) for configuration and read back. An extension of this control bus is embedded in the A<sup>2</sup>B data stream, which grants direct access of registers and status information on sub transceivers as well as I<sup>2</sup>C and SPI communication over distance.

The transceiver can connect directly to general-purpose digital signal processors (DSPs), field-programmable gate arrays (FPGAs), application specific integrated circuits (ASICs), microphones, analog-to-digital converters (ADCs), digital-to-analog converters (DACs), and codecs through a multi-channel I<sup>2</sup>S/TDM interface. It also provides a pulse density modulation (PDM) interface for direct connection of up to four PDM digital microphones.

Finally, the transceiver also supports an A<sup>2</sup>B bus powering feature, where the main node supplies voltage and current to the sub nodes over the same daisy-chained, twisted pair cable as used for the communication link. Please refer to the datasheet for more details.

## ADA4661 -18 V, Precision, 725 $\mu$ A, 4 MHz, CMOS RRIO Operational Amplifier

The [ADA4661-2](#) is a dual, precision, rail-to-rail input/output amplifier optimized for low power, high bandwidth, and wide operating supply voltage range applications.

The ADA4661-2 performance is guaranteed at 3.0 V, 10 V, and 18 V power supply voltages. It is an excellent selection for applications that use single-ended supplies of 3.3 V, 5 V, 10 V, 12 V and 15 V, and dual supplies of  $\pm 2.5$  V,  $\pm 3.3$  V, and  $\pm 5$  V. It uses the Analog Devices, Inc., patented DigiTrim<sup>®</sup> trimming technique, which achieves low offset voltage. Additionally, the unique design architecture of the ADA4661-2 allows it to have excellent power supply rejection, common-mode rejection, and offset voltage when operating in the common-mode voltage range of  $-V_{SY} + 1.5$  V to  $+V_{SY} - 1.5$  V.

## ADAU1701 SigmaDSP 28-/56-Bit Audio Processor with Two ADCs and Four DACs

The [ADAU1701](#) is a complete single-chip audio system with a 28-/56-bit audio DSP, ADCs, DACs, and microcontroller-like control interfaces. Signal processing includes equalization, crossover, bass enhancement, multiband dynamics processing, delay compensation, speaker compensation, and stereo image widening. This processing can be used to compensate for real-world limitations of speakers, amplifiers, and listening environments, providing dramatic improvements in perceived audio quality.

Its signal processing is comparable to that found in high end studio equipment. Most processing is done in full 56-bit, double precision mode, resulting in very good low level signal performance. The ADAU1701 is a fully programmable DSP. The easy to use SigmaStudio+™ software allows the user to graphically configure a custom signal processing flow using blocks such as biquad filters, dynamics processors, level controls, and GPIO interface controls.

ADAU1701 programs can be loaded on power-up either from a serial EEPROM through its own self-boot mechanism or from an external microcontroller. On power-down, the current state of the parameters can be written back to the EEPROM from the ADAU1701 to be recalled the next time the program is run.

Two  $\Sigma$ - $\Delta$  ADCs and four  $\Sigma$ - $\Delta$  DACs provide a 98.5 dB analog input to analog output dynamic range. Each ADC has a THD + N of -83 dB, and each DAC has a THD + N of -90 dB. Digital input and output ports allow a seamless connection to additional ADCs and DACs. The ADAU1701 communicates through an I2C bus or a 4-wire SPI port.

## ADP2360 - 50 mA, 60 V, High Efficiency Buck Regulator

The [ADP2360](#) is a high efficiency, high input voltage, discontinuous conduction mode (DCM) synchronous, step-down, dc-to-dc switching regulator. The ADP2360 operates with a wide input voltage supply range from 4.5 V to 60 V and can source up to 50 mA continuous output current, making it ideal for regulating power from a variety of voltage sources in space-constrained applications. The ADP2360 is available with an adjustable output (0.8 V to VIN) or in 3.3 V and 5.0 V factory-programmable fixed output voltage models.

## BD28623MUV - Class D Speaker Amplifier

The [BD28623MUV](#) is a Class D Speaker Amplifier designed for Flat-panel TVs in particular for space-saving and low-power consumption. This IC delivers an output power of 20W+20W.

## IM69D120 High Performance Digital MEMS Microphone

[IM69D120](#) is a high performance digital MEMS microphone making use of Infineon's Dual Backplate MEMS technology to deliver 95dB dynamic range and high output linearity up to 120dB SPL.

## LT3502/LT3502A - 1.1MHz/2.2MHz, 500mA Step-Down Regulators in 2mm × 2mm DFN and MS10

The [LT3502/LT3502A](#) are current mode PWM step-down DC/DC converters with an internal 500mA power switch, in tiny 8-lead 2mm × 2mm DFN and 10-lead MS10 packages. The wide input voltage range of 3V to 40V makes the LT3502/LT3502A suitable for regulating power from a wide variety of sources, including 24V industrial supplies and automotive batteries. Its high operating frequency allows the use of tiny, low cost inductors and capacitors, resulting in a very small solution. Constant frequency above the AM band avoids interfering with radio reception, making the LT3502A particularly suitable for automotive applications. Cycle-by-cycle current limit and

frequency foldback provide protection against shorted outputs. Soft-start and frequency foldback eliminates input current surge during start-up. DA current sense provides further protection in fault conditions. An internal boost diode reduces component count.

## **M24512-RMN6TP - Automotive 512-Kbit Serial I<sup>2</sup>C EEPROM with 1MHz clock**

The [M24512](#) is a 512-Kbit I2C-compatible EEPROM (electrically erasable programmable memory) organized as 64 K × 8 bits. The M24512-W can operate with a supply voltage from 2.5 V to 5.5 V, the M24512-R can operate with a supply voltage from 1.8 V to 5.5 V, and the M24512-DF can operate with a supply voltage from 1.7 V to 5.5 V.

All these devices operate with a clock frequency of 1 MHz (or less), over an ambient temperature range of –40 °C / +85 °C. The M24512-D offers an additional page, named the identification page (128 byte). The identification page can be used to store sensitive application parameters which can be (later) permanently locked in read-only mode.

## 3 Hardware Reference

This chapter describes the hardware design of the *EVAL-AD2437B1MZ*.

### Connectors

This section describes connector functionality and provides information about mating connectors. The connector locations are shown in the *Connector Locations* figure.

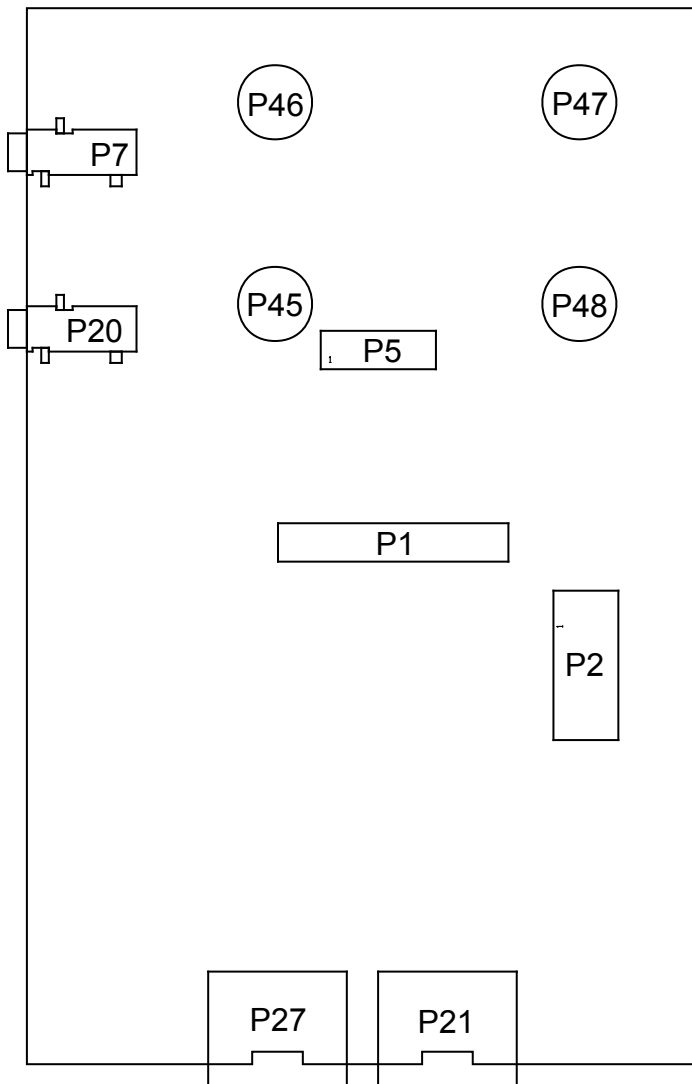

Figure 3-1: Connector Locations

## Stereo Connectors( TP5-TP8 )

TP5-TP8 are used to connect stereo speakers to the board. It is not recommended that speaker impedance be lower than 8 Ohms.

Connector	Speaker Side
TP5	SPKR L-
TP6	SPKR L+
TP7	SPKR R-
TP8	SPKR R+



## Audio I2S Connector ( P1 )

This connector has all I2S signals, it can be interfaced with external custom boards if required or used for probing. The pinout can be found in the schematic.

## SigmaStudio+ ( P2 )

This connector interfaces with SigmaStudio+ through the [EVAL-ADUSB2EBZ](#) board. The connector is a 0.1" header. The pinout can be found in the schematic.

## Multipurpose pins( P5 )

For use of interfacing with the multi-purpose pins of the ADAU1701. Further information can be found in the schematic.

## ADC Input Connector( P7 )

The ADAU1701 has two  $\Sigma$ - $\Delta$  ADCs. P7 will supply the input signal through a 3.5 mm stereo TRS connector

<i>Part Description</i>	<i>Manufacturer</i>	<i>Part Number</i>
3.5mm headphone jack	CUI Devices	SJ-3523-SMT

## DAC Output Connector( P20 )

The ADAU1701 includes four  $\Sigma$ - $\Delta$  DACs. will supply output signals through a 3.5 mm TRS connector.

<i>Part Description</i>	<i>Manufacturer</i>	<i>Part Number</i>
3.5mm headphone jack	CUI Devices	SJ-3523-SMT

## A<sup>2</sup>B ( P27 and P21 )

P21 is used to connect towards a Sub Node and P27 is used to connect towards the main node. These connectors allow the AD2437 on the eval board to allow communication with other A<sup>2</sup>B devices on the bus.

<i>Part Description</i>	<i>Manufacturer</i>	<i>Part Number</i>
RJ45 - Ethernet	Amphenol ICC	RJE73-188-00210
<i>Mating Cable</i>		
Ethernet cable assembly		

## Jumpers

This section describes functionality of the configuration jumpers. The *Jumper Locations* figure shows the jumper locations.

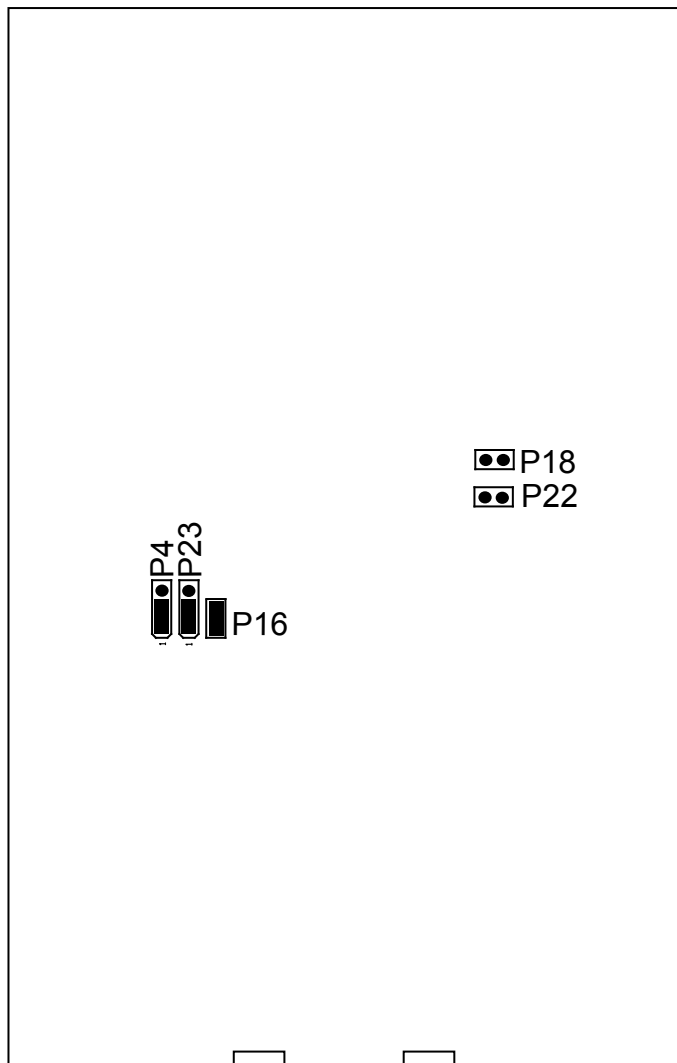

Figure 3-2: Jumper Configurations

### AD2437 SIO0 Routing ( P4)

The AD2437 SIO0 jumper can be configured as ADAU1701\_SDATA\_OUT or PDM\_DATA0. The default setting for the jumper is pins 1 and 2.

Jumper	Routing
1 and 2 (DEFAULT)	PDM_DATA0

Jumper	Routing
2 and 3	ADAU1701_SDATA_OUT

## AD2437 SIO1 Routing ( P23)

The AD2437 SIO1 jumper can be configured as BD28623\_MUTEX (Mute Control for Class D Amplifier) or PDM\_DATA1. The default setting for the jumper is pins 1 and 2.

Jumper	Routing
1 and 2 (DEFAULT)	PDM_DATA1
2 and 3	BD28623 MUTEX

## AD2437 BCLK Select ( P16)

AD2437 BCLK Jumper is used to route AD2437's BCLK to the PDM Microphones as their clock source.

Jumper	Clock Routing
P16 (Shunt On)	BCLK to PDM CLK (Pins 1-2)

## ADAU1701 I2C Bus Switch ( P18 and P22)

These jumpers are used to close the I2C bus of the ADAU1701 and its EEPROM into the USBi and AD2437 I2C bus.

Jumper P18	Jumper P22	ADAU1701_MP1	I2C Bus Switch (U12 , U14)	Use Case and Action
CLOSED	OPEN	X	CLOSED	Program/Parameter write from AD2437 or USBi to ADAU1701 or Boot EEPROM
OPEN (DEFAULT)	OPEN (DEFAULT)	X	CLOSED	Program/Parameter write from AD2437 or USBi to ADAU1701
X	CLOSED	1 -> 0	OPEN -> CLOSED	SELFBOT of ADAU1701 from Boot EEPROM
X	X	1	OPEN	Parameter write from ADAU1701 to BOOT EEPROM

## LEDs

This section describes the on-board LEDs. The *LED Locations* figure shows the LED locations.

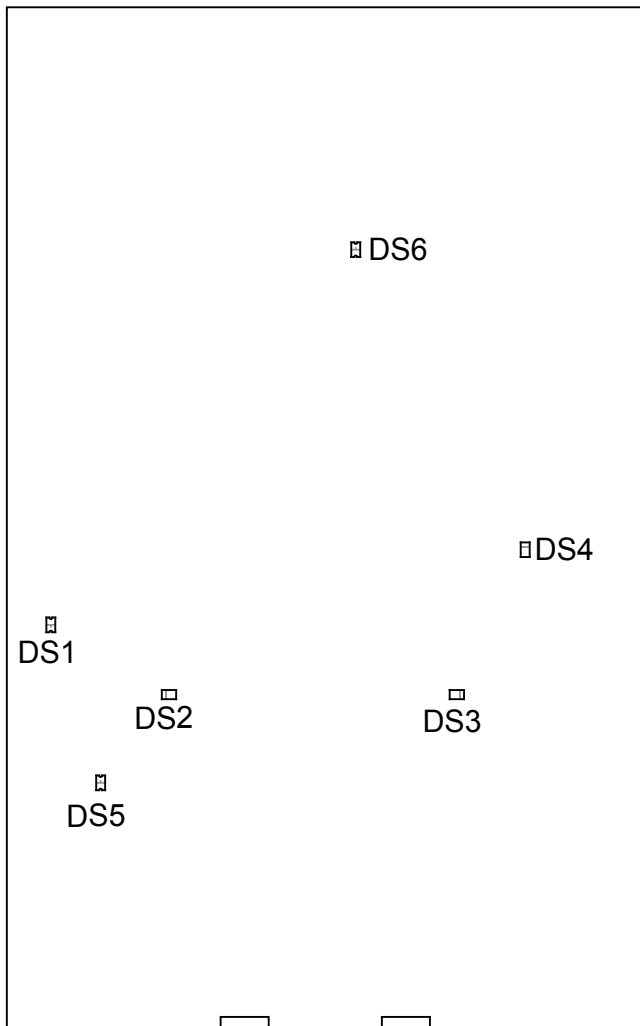

Figure 3-3: LED Locations

## A<sup>2</sup>B Interrupt ( DS2)

The A<sup>2</sup>B interrupt LED is driven by the AD2437. The LED is turned on when the IRQ pin drives it high.

## Power Status Indicator ( DS1, DS3, DS5)

The Status Indicators indicate Supplies health i.e. They will be on when the respective supply will be available on board.

DS5 : +5.0V

DS1 : +3.3V

DS3 : Power ON

## **I2C Bus Switch ( DS4)**

The Bus Switch LED is used to indicate the I2C bus of the ADAU1701 and its EEPROM are connected into the I2C bus for the AD2437 and USBi.

## **BD28623MUV Error Status ( DS6)**

An error flag is outputted for output short protection, DC voltage protection in the speaker, and high temperature protection. By default, this LED will be high. When low, an ERROR has occurred. Refer to the BD28623MUV datasheet for more information on what causes the error indication.

