

150V Half-Bridge Driver with Adaptive Shoot-through Protection

General Description

The EVAL-LTC7068-AZ evaluation circuit features [LTC7068](#) driving two N-channel MOSFETs in a half-bridge configuration. The PWM input control is 5V logic compatible and controls both gate outputs, with one output complementing the other. The evaluation board has several unpopulated Printed Circuit Board (PCB) pads to help the user customize the board for their application.

The LTC7068 driver has powerful 1.3Ω pull-down and 1.6Ω pull-up MOSFET drivers driving two 150V N-Channel MOSFETs.

Design files for this circuit board are available at [Product Evaluation Boards and Kits | Design Center | Analog Devices](#).

Performance Summary (T_A = 25°C)

PARAMETER	CONDITIONS	MIN	TYP	MAX	UNITS
Logic-Input Supply (VIN-LOGIC)		6		14	V
Power-Input Supply (VIN-POWER)				150	V
Maximum Output Current				10	A
PWM Control Frequency				2,000+	kHz
Maximum Pulse-width Modulation (PWM) Control Voltage				5.5	V

Quick Start Procedure

The EVAL-LTC7068-AZ can be evaluated without connecting any additional components or a load; however, the user may find adding two load resistors, as shown in [Figure 1](#), provides a better means for evaluation. Alternatively, the user can configure their application circuit. Test with resistor divider as a load:

- Connect two 100Ω power resistors to the SW node, as shown in [Figure 1](#).
- Apply VIN-POWER supply.
- Apply VIN-LOGIC supply.
- Apply square-wave signal at a desired frequency to the PWM pin, as shown in [Figure 1](#).
- Ensure the JP1 jumper is set to “ENABLED”.
- Monitor the BG, TG, and SW pins with a scope.
- See [Figure 2](#) for expected results with:
 - a. VIN-POWER = 40V
 - b. VIN-LOGIC = 10V
 - c. The PWM input is set at a 5V peak at 1kHz.

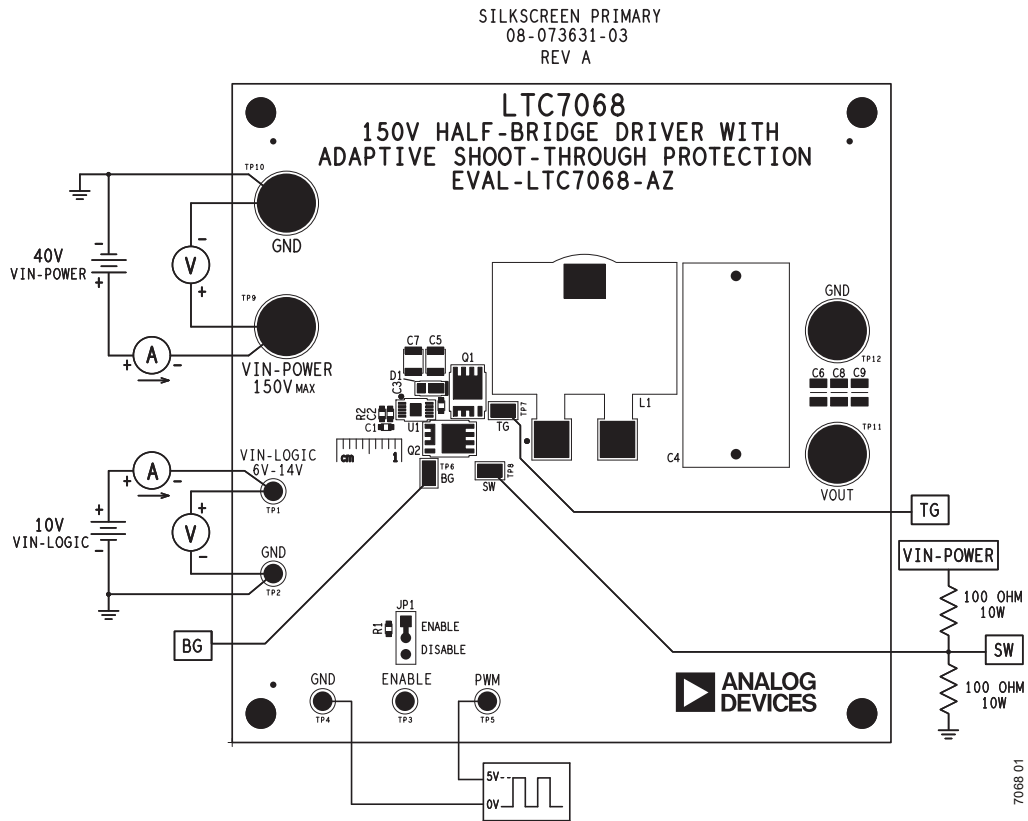

Figure 1. EVAL-LTC7068-AZ Test Setup

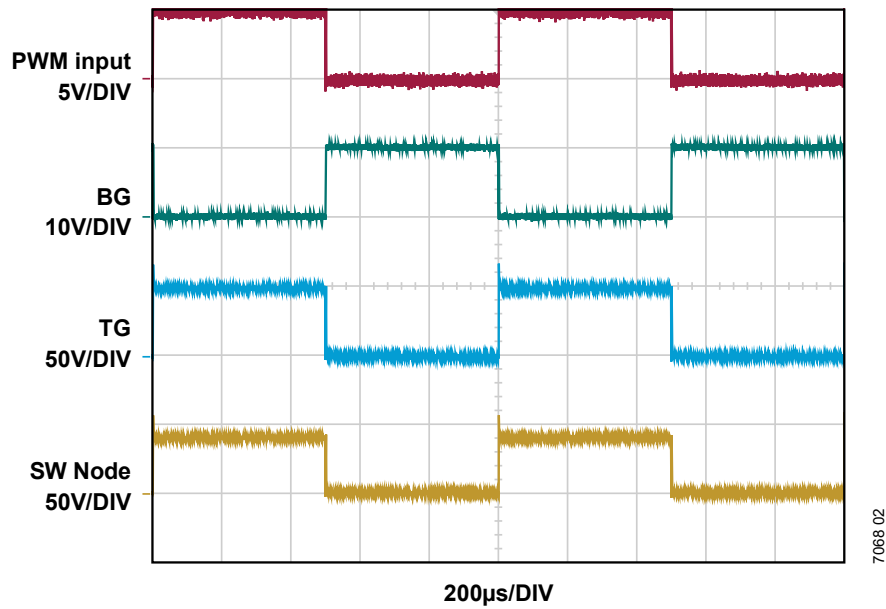

Figure 2. Test Results

Evaluation Board Schematic

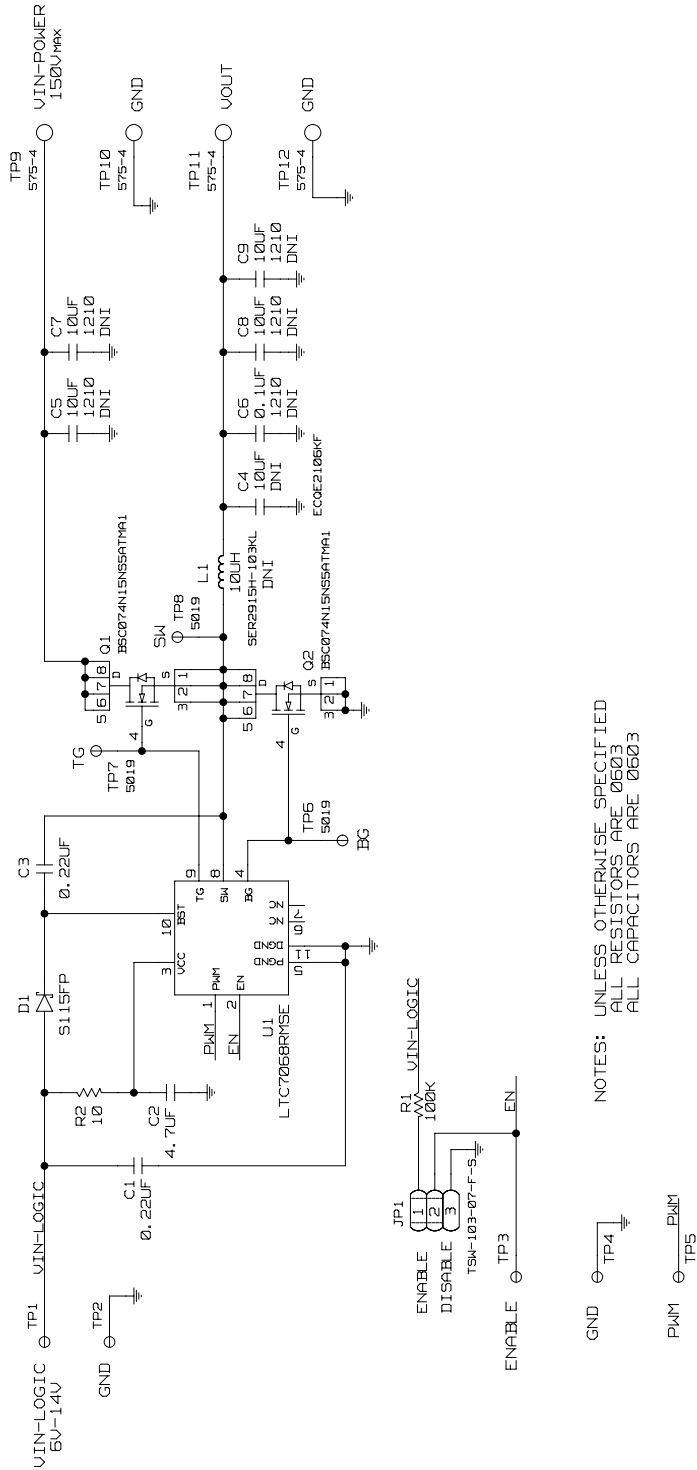

Figure 3. EVAL-LTC7068-AZ Schematic

Revision History

REVISION NUMBER	REVISION DATE	DESCRIPTION	PAGES CHANGED
0	02/24	Initial release	—

ASSUMED BY ANALOG DEVICES FOR ITS USE, NOR FOR ANY INFRINGEMENTS OF PATENTS OR OTHER RIGHTS OF THIRD PARTIES THAT MAY RESULT FROM ITS USE. SPECIFICATIONS ARE SUBJECT TO CHANGE WITHOUT NOTICE. NO LICENCE, EITHER EXPRESSED OR IMPLIED, IS GRANTED UNDER ANY ADI PATENT RIGHT, COPYRIGHT, MASK WORK RIGHT, OR ANY OTHER ADI INTELLECTUAL PROPERTY RIGHT RELATING TO ANY COMBINATION, MACHINE, OR PROCESS WHICH ADI PRODUCTS ALL INFORMATION CONTAINED HEREIN IS PROVIDED "AS IS" WITHOUT REPRESENTATION OR WARRANTY. NO RESPONSIBILITY IS OR SERVICES ARE USED. TRADEMARKS AND REGISTERED TRADEMARKS ARE THE PROPERTY OF THEIR RESPECTIVE OWNERS.