

ADPL16000A/ADPL16000B/ ADPL16000C Evaluation Kits

Evaluate: ADPL16000 Converters in Application

General Description

The ADPL16000A/ADPL16000B/ADPL16000C evaluation kits (EV kits) provide proven designs to evaluate the performance of the ADPL16000A/ADPL16000B/ADPL16000C high-voltage, high-efficiency, synchronous step-down DC-DC converters. The ADPL16000A converter operates over a 5V to 48V input range and can deliver up to 400mA at a fixed 3.3V output. The ADPL16000B converter operates over a 7V to 60V input range and can deliver up to 400mA at a fixed 5V output. The ADPL16000C converter operates over a 15V to 60V input range and can deliver up to 400mA at an adjustable 12V output.

The EV kits feature an adjustable input undervoltage-lockout, open-drain RESET, overcurrent protection, selectable mode of operation, and thermal shutdown. Refer to the ADPL16000 converter data sheet for a complete description of the part that should be read in conjunction with this data sheet before operating these EV kits.

Features

- Operates up to 60V Input Supply
- Fixed 5V, Fixed 3.3V, and Adjustable 12V Application Circuits
- Up to 400mA Load Current
- 500kHz Fixed Switching Frequency
- Enable/UVLO Input, Resistor-Programmable UVLO Threshold
- Selectable PWM and PFM Modes of Operation
- Open-Drain RESET Output
- Overcurrent and Overtemperature Protection
- Proven PCB Layout
- Fully Assembled and Tested
- Complies with CISPR32(EN55032) Class B Conducted and Radiated Emissions

[Ordering Information](#) appears at end of data sheet.

EV Kit Photo

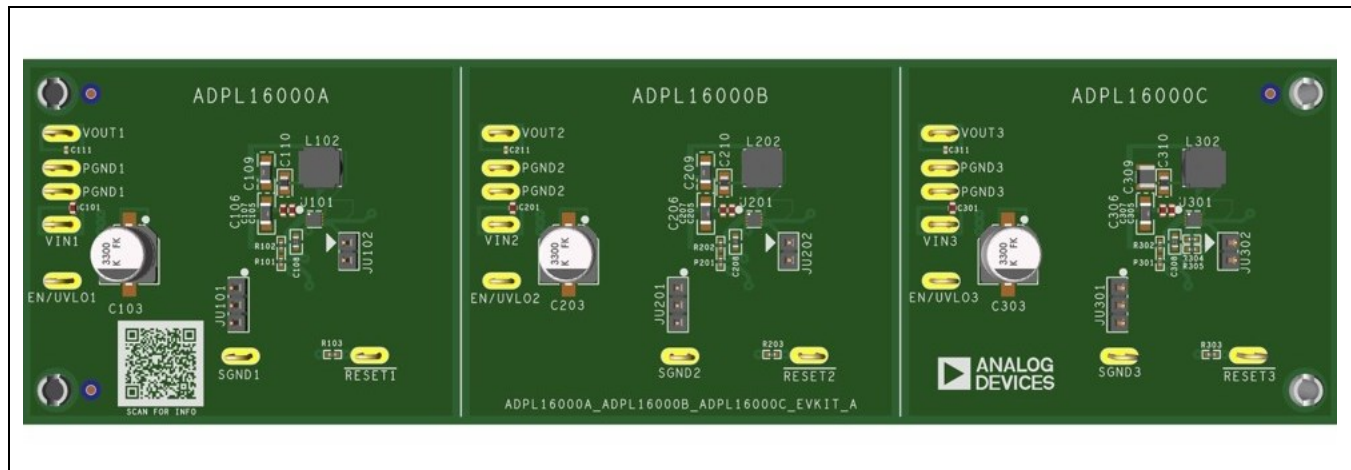

TABLE OF CONTENTS

General Description	1
Features	1
EV Kit Photo.....	1
Quick Start	3
Required Equipment.....	3
Equipment Setup and Procedure	3
Detailed Description	3
Enable/Undervoltage Lockout (EN/UVLO) Programming	3
Mode Selection.....	4
Adjusting Output Voltage.....	4
Input Capacitor Selection	4
Output Capacitor Selection	5
Hot Plug-In and Long Input Cables	5
Electromagnetic Interference (EMI).....	5
ADPL16000A/ADPL16000B/ADPL16000C EV Kits Performance Report	6
Component Suppliers	11
Ordering Information	11
ADPL16000A EV Kit Bill of Materials.....	12
ADPL16000A 3.3V Application Circuit.....	12
ADPL16000B EV Kit Bill of Materials.....	13
ADPL16000B 5V Application Circuit	13
ADPL16000C EV Kit Bill of Materials.....	14
ADPL16000C 12V Application Circuit.....	14
ADPL16000A EV Kit Schematic Diagram	15
ADPL16000B EV Kit Schematic Diagram	16
ADPL16000C EV Kit Schematic Diagram.....	17
ADPL16000A/ADPL16000B/ADPL16000C EV Kits PCB Layout Diagrams	18
ADPL16000A/ADPL16000B/ADPL16000C EV Kits PCB Layout Diagrams (Continued)	19
ADPL16000A/ADPL16000B/ADPL16000C EV Kits PCB Layout Diagrams (Continued)	20
Revision History	21

Quick Start

Required Equipment

- One 60V, 400mA DC power supply
- Digital multimeters (DMM)
- Load resistors capable of sinking up to 400mA (8.25Ω for ADPL16000A, 12.5Ω for ADPL16000B, and 30Ω for ADPL16000C)

Equipment Setup and Procedure

The EV kits are fully assembled and tested. Follow the steps to verify and test individual converter operation:

Caution: Do not turn on power supply until all connections are completed.

- 1) Disable the power supply and set the input power supply at a valid input voltage.
- 2) Connect the positive terminal and negative terminal of the power supply to the VIN pad and its adjacent PGND pad of the converter under evaluation.
- 3) Connect the positive terminal of the 400mA (max) load to the VOUT pad and the negative terminal to the nearest PGND pad of the corresponding converter.
- 4) Connect the DMM across the VOUT pad and the nearest PGND pad.
- 5) Verify that the shunts are not installed across pins on jumper JU101 for ADPL16000A, JU201 for ADPL16000B, and JU301 for ADPL16000C. See [Table 1](#) for details.
- 6) Turn on the input power supply.
- 7) Verify that the DMMs display the expected terminal voltages with respect to GND.

Detailed Description

The ADPL16000A/ADPL16000B/ADPL16000C EV kits are designed to demonstrate the salient features of the ADPL16000A/ADPL16000B/ADPL16000C high-voltage, high-efficiency, synchronous step-down DC-DC converters. The EV kits consist of typical application circuits of three different converters. Each of these circuits is electrically isolated from each other and hosted on the same PCB. Each of these converters can be evaluated for their performance under different operating conditions by powering them from their respective input pins.

Enable/Undervoltage Lockout (EN/UVLO) Programming

The EV kits offer an adjustable input undervoltage-lockout level feature for the converters. For the ADPL16000A, when jumper JU101 is left open, the converter is enabled when the input voltage rises above 5V. To disable the ADPL16000A, install a shunt across pins 2-3 on jumper JU101. For the ADPL16000B, when jumper JU201 is left open, the converter is enabled when the input voltage rises above 7V. To disable the ADPL16000B, install a shunt across pins 2-3 on the jumper JU201. For the ADPL16000C, when jumper JU301 is left open, the converter is enabled when the input voltage rises above 15V. To disable the ADPL16000C, install a shunt across pins 2-3 on the jumper JU301. See [Table 1](#) for jumper settings. Refer to the Setting the Input Undervoltage-Lockout Level section in the ADPL16000 data sheet for more details.

If the EN/UVLO pin is driven from an external signal source, it is recommended that a minimum 1kΩ series resistance is placed between the signal source output and the EN/UVLO pin to reduce voltage ringing on the line.

Mode Selection

The ADPL16000A/ADPL16000B/ADPL16000C converters support PWM and PFM modes of operation. In the EV kits, leave the jumpers (JU102 for ADPL16000A, JU202 for ADPL16000B, and JU302 for ADPL16000C) open for operating the modules in PFM mode at light load. Install shunts across positions 1-2 to configure the modules in PWM mode. See [Table 2](#) for jumper settings. Refer to the Mode Selection (MODE) section in the ADPL16000 data sheet for more details.

Adjusting Output Voltage

The ADPL16000C supports a $0.9V$ to $(0.89 \times V_{IN})V$ adjustable output voltage. Output Voltage in the ADPL16000C EV kit is preset to $12V$. Output voltage can be programmed using the feedback-resistive divider (R304 and R305) from VOUT and GND. For programming the output to a different voltage, refer to the Adjusting the Output Voltage section in the ADPL16000 data sheet for more details.

Input Capacitor Selection

The input capacitors C106 for the ADPL16000A, C206 for the ADPL16000B, and C306 for the ADPL16000C, serve to reduce current peaks drawn from the input power supply and reduce switching frequency ripple at the input. Refer to the Input Capacitor section in the ADPL16000 data sheet to choose input capacitance. Input capacitor is chosen to be $1\mu F/100V$ for the ADPL16000A/ADPL16000B/ADPL16000C EV kits.

Table 1. EN/UVLO Jumper Description (JU101, JU201, and JU301)

SHUNT POSITION	EN/UVLO PIN	OUTPUT
Not installed*	Connected to the center nodes of the respective resistor-dividers (R101 and R102 for 3.3V application circuit; R201 and R202 for 5V application circuit; R301 and R302 for 12V application circuit)	Programmed to startup at desired input-voltage level
1-2	Connected to VIN	Enabled
2-3	Connected to GND	Disabled

*Default position

Table 2. MODE Jumper Description (JU102, JU202, and JU302)

SHUNT POSITION	EN/UVLO PIN	OUTPUT
Not installed*	Unconnected	PFM mode of operation
1-2	Connected to GND	PWM mode of operation

*Default position

Output Capacitor Selection

X7R ceramic capacitors are preferred due to their stability over temperature in industrial applications. The required output capacitor (C109, C209) for the ADPL16000A and ADPL16000B is 22 μ F/6.3V. The required Output Capacitor (C309) for the ADPL16000C is 22 μ F/16V. Refer to the Output Capacitor section in the ADPL16000 data sheet for more details.

Hot Plug-In and Long Input Cables

The EV kits provide optional electrolytic capacitors 22 μ F/100V (C103 for the ADPL16000A, C203 for the ADPL16000B, and C303 for the ADPL16000C) to dampen input voltage peaks and oscillations that may arise during hot-plug-in and/or due to long input cables. These capacitors limit the peak voltage at the input of the DC-DC converters when the EV kits are powered directly from a precharged capacitive source or an industrial backplane PCB. Long input cables, between the input power source and the EV kit circuit, can cause input-voltage oscillations due to the inductance of the cables. The equivalent series resistance (ESR) of the electrolytic capacitor helps damp out the oscillations caused by long input cables.

Electromagnetic Interference (EMI)

Compliance to conducted emissions (CE) standards requires an EMI filter at the input of a switching power converter. The EMI filter attenuates high-frequency currents drawn by the switching power converter and limits the noise injected back into the input power source.

Use of EMI filter components as shown in the EV kit schematic results in lower conducted emissions, below CISPR32 Class B limits. Manufacturer part numbers of the EMI filter components are listed as optional BOM. The EV kits' PCB layout are also designed to limit radiated emissions from switching nodes of the power converter, resulting in radiated emissions below CISPR32 Class B limits. Further, capacitors placed near the input of the board help in attenuating high-frequency noise.

ADPL16000A/ADPL16000B/ADPL16000C EV Kits Performance Report

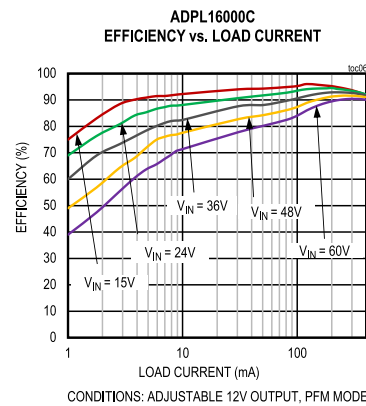
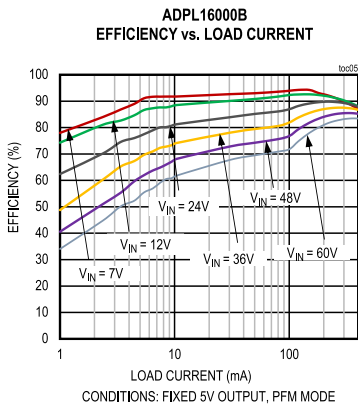
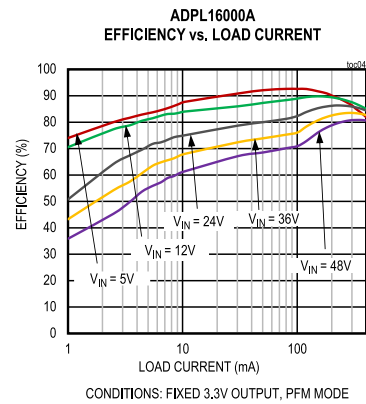
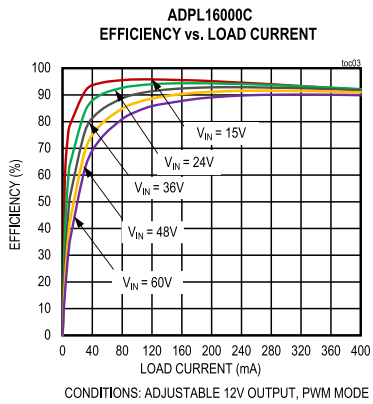
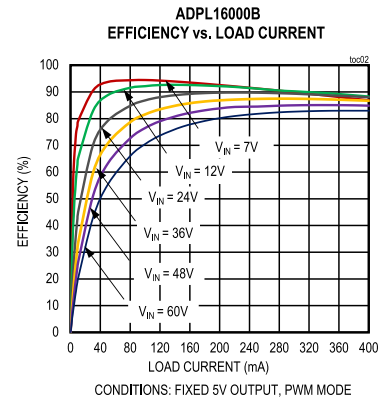
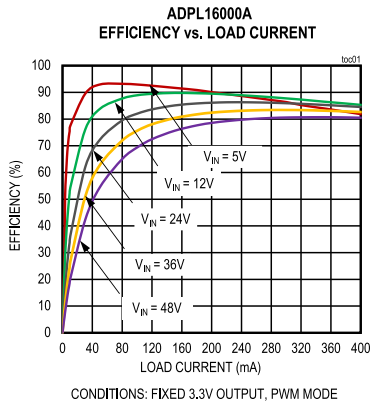

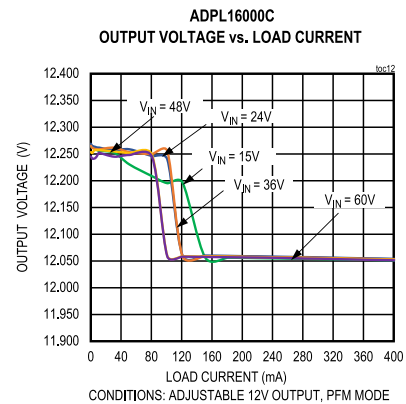
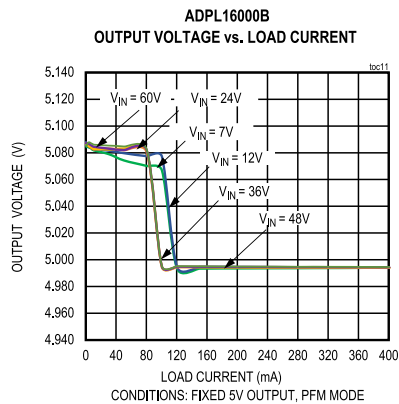
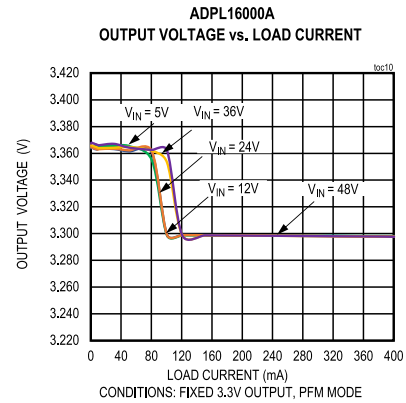
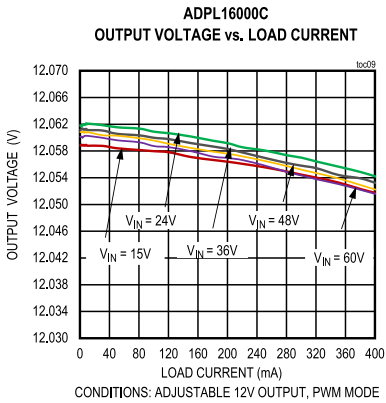
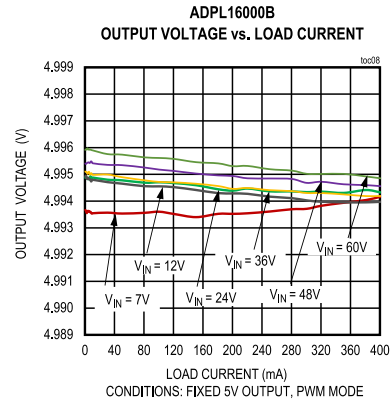
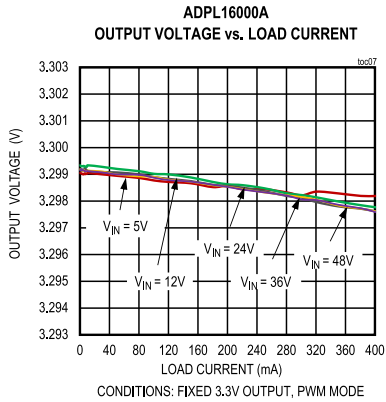

**ADPL16000A
OUTPUT VOLTAGE RIPPLE**

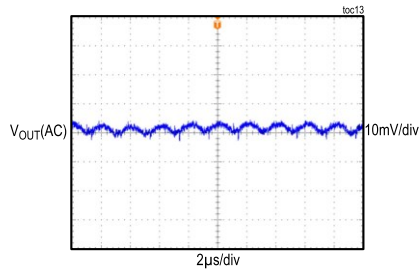

CONDITIONS: FIXED 3.3V OUTPUT,
400mA LOAD, PWM MODE

**ADPL16000B
OUTPUT VOLTAGE RIPPLE**

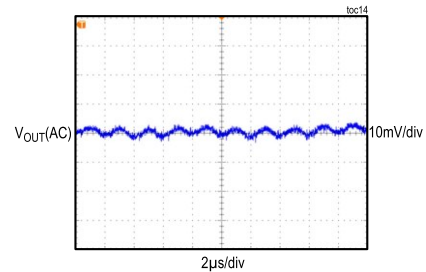

CONDITIONS: FIXED 5V OUTPUT,
400mA LOAD, PWM MODE

**ADPL16000C
OUTPUT VOLTAGE RIPPLE**

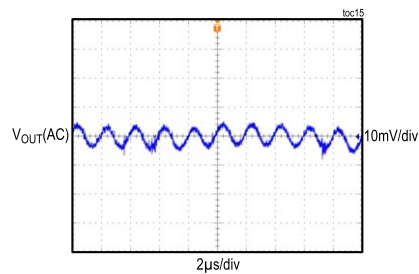

CONDITIONS: ADJUSTABLE 12V OUTPUT
400mA LOAD, PWM MODE

**ADPL16000A
LOAD TRANSIENT RESPONSE**

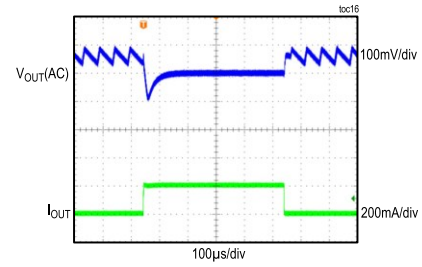

CONDITIONS: PFM MODE, FIXED 3.3V OUTPUT
LOAD STEP BWTWEEN 5mA to 200mA

**ADPL16000A
LOAD TRANSIENT RESPONSE**

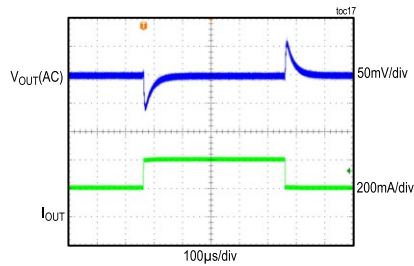

CONDITIONS: PWM MODE, FIXED 3.3V OUTPUT
LOAD STEP BETWEEN 200mA to 400mA

**ADPL16000B
LOAD TRANSIENT RESPONSE**

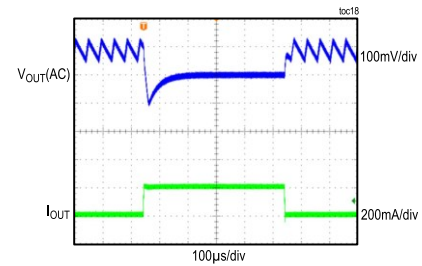

CONDITIONS: PFM MODE, FIXED 5V OUTPUT
LOAD STEP BETWEEN 5mA to 200mA

ADPL16000A/ADPL16000B/ ADPL16000C Evaluation Kits

**ADPL16000B
LOAD TRANSIENT RESPONSE**

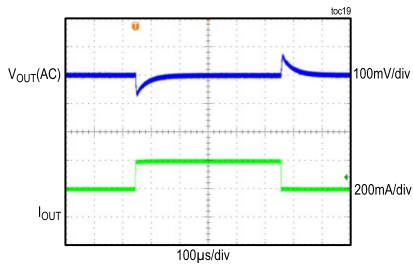

CONDITIONS: PWM MODE, FIXED 5V OUTPUT
LOAD STEP BETWEEN 200mA to 400mA

**ADPL16000C
LOAD TRANSIENT RESPONSE**

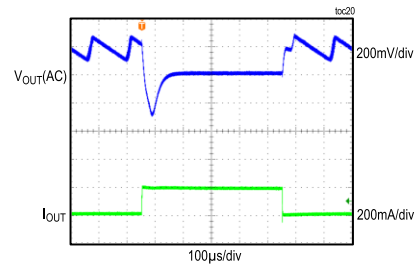

CONDITIONS: PFM MODE, ADJUSTABLE 12V OUTPUT
LOAD STEP BETWEEN 5mA to 200mA

**ADPL16000C
LOAD TRANSIENT RESPONSE**

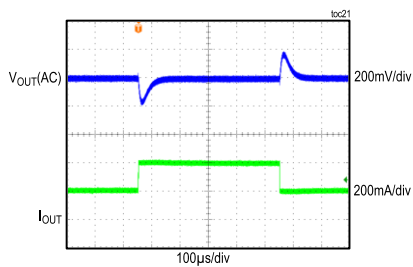

CONDITIONS: PWM MODE, ADJUSTABLE 12V OUTPUT
LOAD STEP BETWEEN 200mA to 400mA

**ADPL16000A
STARTUP THROUGH ENABLE**

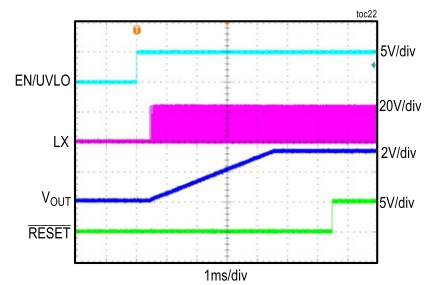

CONDITIONS: FIXED 3.3V OUTPUT,
400mA LOAD, PWM MODE

**ADPL16000B
STARTUP THROUGH ENABLE**

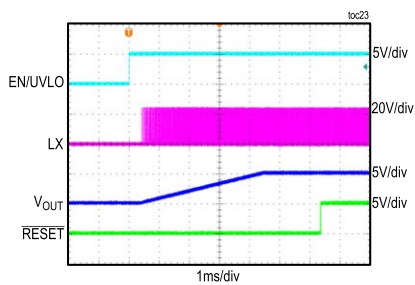

CONDITIONS: FIXED 5V OUTPUT,
400mA LOAD, PWM MODE

**ADPL16000C
STARTUP THROUGH ENABLE**

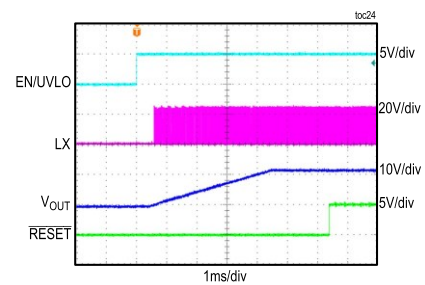

CONDITIONS: ADJUSTABLE 12V OUTPUT,
400mA LOAD, PWM MODE

ADPL16000A/ADPL16000B/ ADPL16000C Evaluation Kits

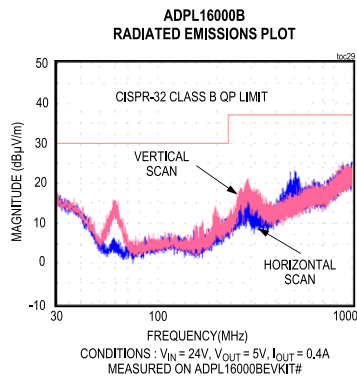
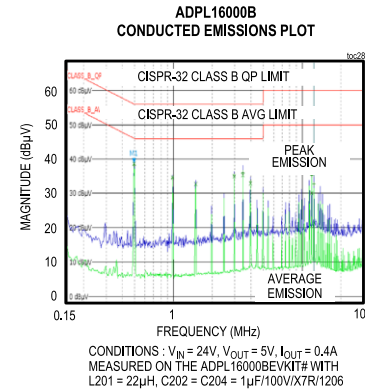
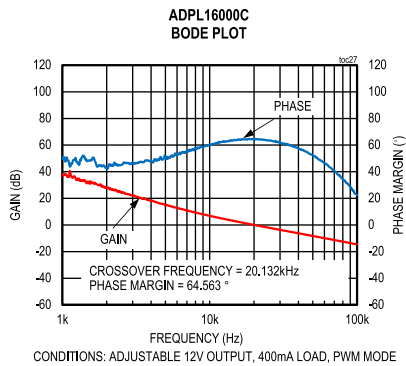
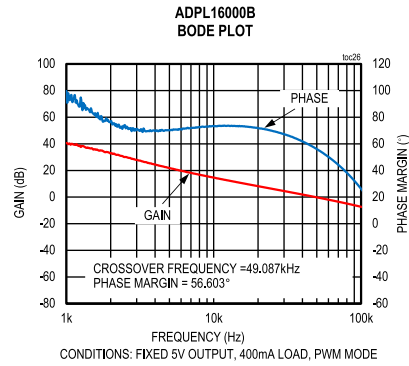
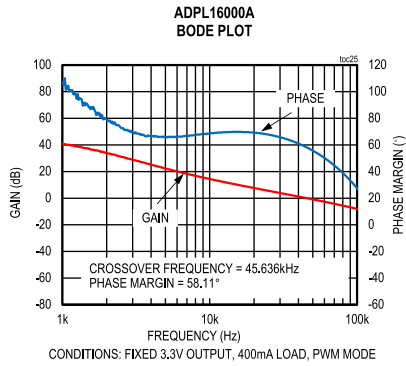

Component Suppliers

SUPPLIER	WEBSITE
Murata Americas	www.murata.com
Panasonic Corp	www.panasonic.com
Taiyo Yuden	www.yuden.co.jp
TDK	www.tdk.com
Vishay	www.vishay.com
Würth Elektronik	www.we-online.com

Note: Indicate that you are using the ADPL16000 when contacting these component suppliers.

Ordering Information

PART NUMBER	TYPE
ADPL16000AEVKIT#	EV Kit
ADPL16000BEVKIT#	EV Kit
ADPL16000C12EVKIT#	EV Kit

#Denotes RoHS compliance.

ADPL16000A EV Kit Bill of Materials

ADPL16000A 3.3V Application Circuit

ITEM	QTY	DESIGNATION	DESCRIPTION	MANUFACTURER PART NUMBER
1	2	C101, C107	0.1 μ F \pm 10%, 100V, X7R Ceramic Capacitor (0603)	TAIYO YUDEN HMK107B7104KA
2	1	C103	22 μ F \pm 20%, 100V, Aluminum Electrolytic capacitor	PANASONIC EEE-FK2A220P
3	1	C105	220pF \pm 5%, 100V, C0G Ceramic Capacitor (0603)	TDK C1608C0G2A221J080AA
4	1	C106	1 μ F \pm 10%, 100V, X7R Ceramic Capacitor (1206)	TAIYO YUDEN HMK316B7105KLH
5	1	C108	1 μ F \pm 10%, 16V, X7R Ceramic Capacitor (0603)	TAIYO YUDEN EMK107B7105KA
6	1	C109	22 μ F \pm 10%, 6.3V, X7R Ceramic Capacitor (1206)	MURATA GRM31CR70J226KE19
7	1	C111	0.1 μ F \pm 10%, 16V, X7R Ceramic Capacitor (0402)	TAIYO YUDEN EMK105B7104KV-F
8	1	L102	INDUCTOR, 47 μ H, 1A	WURTH 74404054470
9	1	R101	1.1M Ω \pm 1% resistor (0402)	VISHAY DALE CRCW04021M10FK
10	1	R102	3.32M Ω \pm 1% resistor (0402)	VISHAY DALE CRCW04023M32FK
11	1	R103	10k Ω \pm 1% resistor (0402)	VISHAY DALE CRCW040210K0FK
12	1	U1	ADPL16000A, Integrated Step-down Converter	ADI ADPL16000AATA+
13	1	L101	Package Outline 2mmx1.9mm inductor	
14	2	C102, C104	Package Outline 1206 capacitor	
15	1	C110	Package Outline 0805 capacitor	

ADPL16000B EV Kit Bill of Materials

ADPL16000B 5V Application Circuit

ITEM	QTY	DESIGNATION	DESCRIPTION	MANUFACTURER PART NUMBER
1	2	C201, C207	0.1 μ F \pm 10%, 100V, X7R Ceramic Capacitor (0603)	TAIYO YUDEN HMK107B7104KA
2	1	C203	22 μ F \pm 20%, 100V, Aluminum Electrolytic capacitor	PANASONIC EEE-FK2A220P
3	1	C205	220pF \pm 5%, 100V, C0G Ceramic Capacitor (0603)	TDK C1608C0G2A221J080AA
4	1	C206	1 μ F \pm 10%, 100V, X7R Ceramic Capacitor (1206)	TAIYO YUDEN HMK316B7105KLH
5	1	C208	1 μ F \pm 10%, 16V, X7R Ceramic Capacitor (0603)	TAIYO YUDEN EMK107B7105KA
6	1	C209	22 μ F \pm 10%, 6.3V, X7R Ceramic Capacitor (1206)	MURATA GRM31CR70J226KE19
7	1	C211	0.1 μ F \pm 10%, 16V, X7R Ceramic Capacitor (0402)	TAIYO YUDEN EMK105B7104KV-F
8	1	L202	INDUCTOR, 68 μ H, 0.8A	WURTH 74404054680
9	1	R201	715k Ω \pm 1% resistor (0402)	VISHAY DALE CRCW0402715KFK
10	1	R202	3.32M Ω \pm 1% resistor (0402)	VISHAY DALE CRCW04023M32FK
11	1	R203	10k Ω \pm 1% resistor (0402)	VISHAY DALE CRCW040210K0FK
12	1	U1	ADPL16000B, Integrated Step-down Converter	ADI ADPL16000BATA+
13	1	L201	OPTIONAL: 22 μ H \pm 20%, 390mA Shielded Wirewound Inductor	COILCRAFT XPL2010-223ML
14	2	C202, C204	OPTIONAL: 1 μ F \pm 10%, 100V, X7R Ceramic Capacitor (1206)	TAIYO YUDEN HMK316B7105KLH
15	1	C210	Package Outline 0805 capacitor	

ADPL16000C EV Kit Bill of Materials

ADPL16000C 12V Application Circuit

ITEM	QTY	DESIGNATION	DESCRIPTION	MANUFACTURER PART NUMBER
1	2	C301, C307	0.1 μ F \pm 10%, 100V, X7R Ceramic Capacitor (0603)	TAIYO YUDEN HMK107B7104KA
2	1	C303	22 μ F \pm 20%, 100V, Aluminum Electrolytic capacitor	PANASONIC EEE-FK2A220P
3	1	C305	220pF \pm 5%, 100V, C0G Ceramic Capacitor (0603)	TDK C1608C0G2A221J080AA
4	1	C306	1 μ F \pm 10%, 100V, X7R Ceramic Capacitor (1206)	TAIYO YUDEN HMK316B7105KLH
5	1	C308	1 μ F \pm 10%, 16V, X7R Ceramic Capacitor (0603)	TAIYO YUDEN EMK107B7105KA
6	1	C309	22 μ F \pm 10%, 16V, X7R Ceramic Capacitor (1210)	MURATA GRM32ER71C226KEA8
7	1	C311	0.1 μ F \pm 10%, 16V, X7R Ceramic Capacitor (0402)	TAIYO YUDEN EMK105B7104KV-F
8	1	L302	INDUCTOR, 150 μ H, 0.6A	WURTH 74404054151
9	1	R301	301k Ω \pm 1% resistor (0402)	VISHAY DALE CRCW0402301KFK
10	1	R302	3.32M Ω \pm 1% resistor (0402)	VISHAY DALE CRCW04023M32FK
11	1	R303	10k Ω \pm 1% resistor (0402)	VISHAY DALE CRCW040210K0FK
12	1	R304	499k Ω \pm 1% resistor (0402)	VISHAY DALE CRCW0402499KFK
13	1	R305	40.2k Ω \pm 1% resistor (0402)	VISHAY DALE CRCW040240K2FK
14	1	U1	ADPL16000C, Integrated Step-down Converter	ADI ADPL16000CATA+
15	1	L301	Package Outline 2mmx1.9mm inductor	
16	2	C302, C304	Package Outline 1206 Capacitor	
17	1	C310	Package Outline 0805 Capacitor	

ADPL16000A EV Kit Schematic Diagram

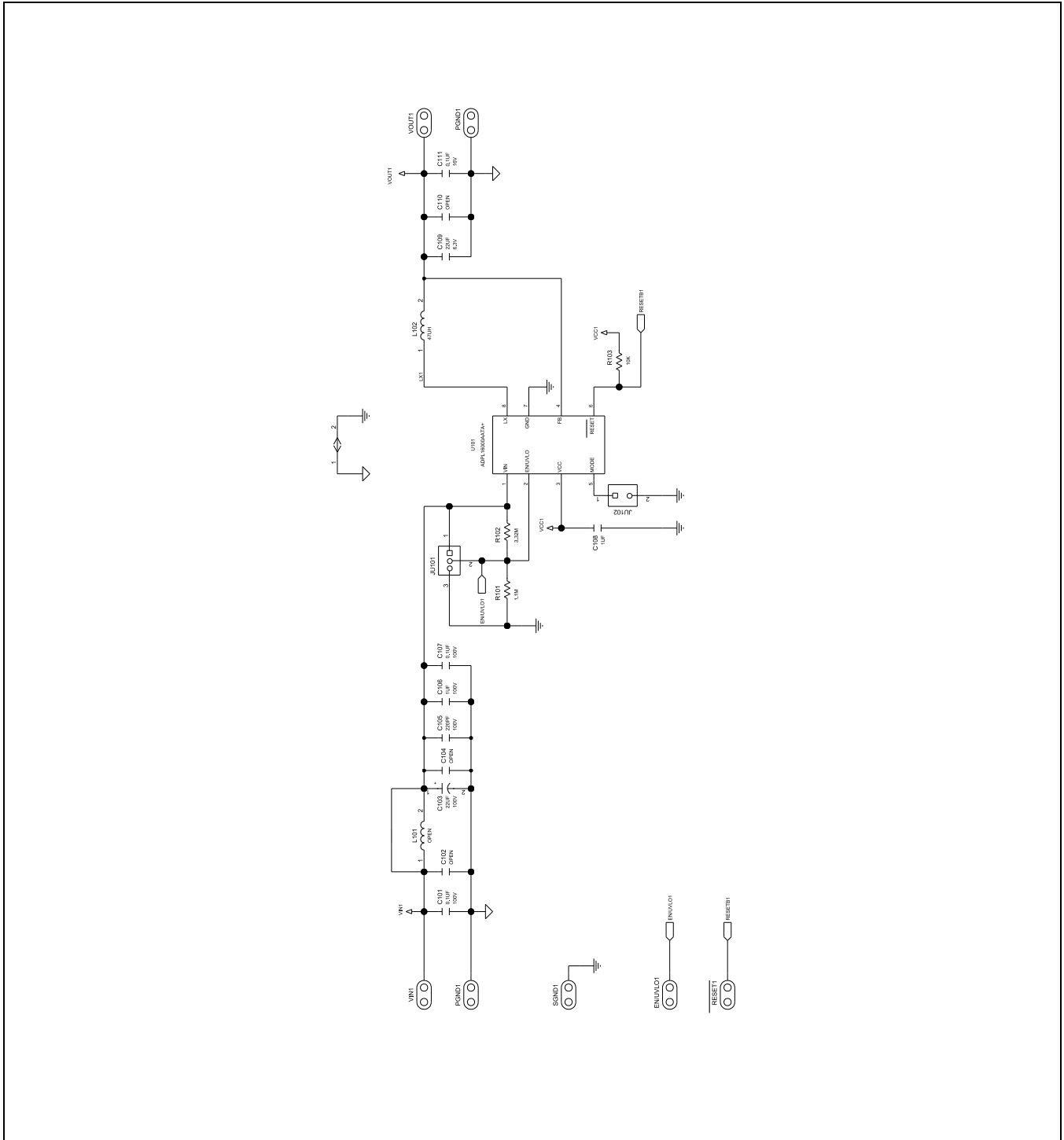

ADPL16000B EV Kit Schematic Diagram

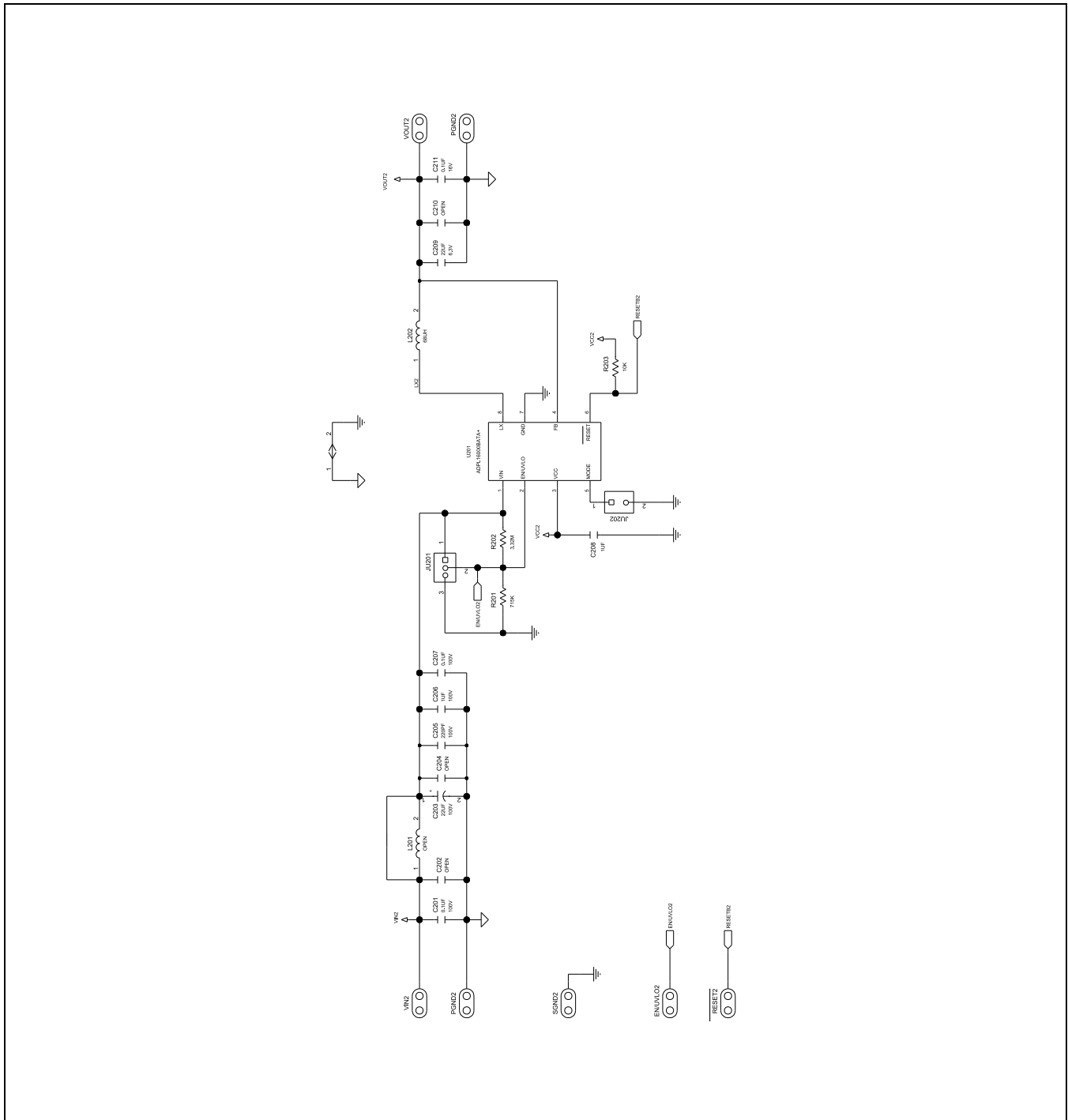

ADPL16000A/ADPL16000B/ADPL16000C EV Kits PCB Layout Diagrams

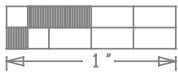
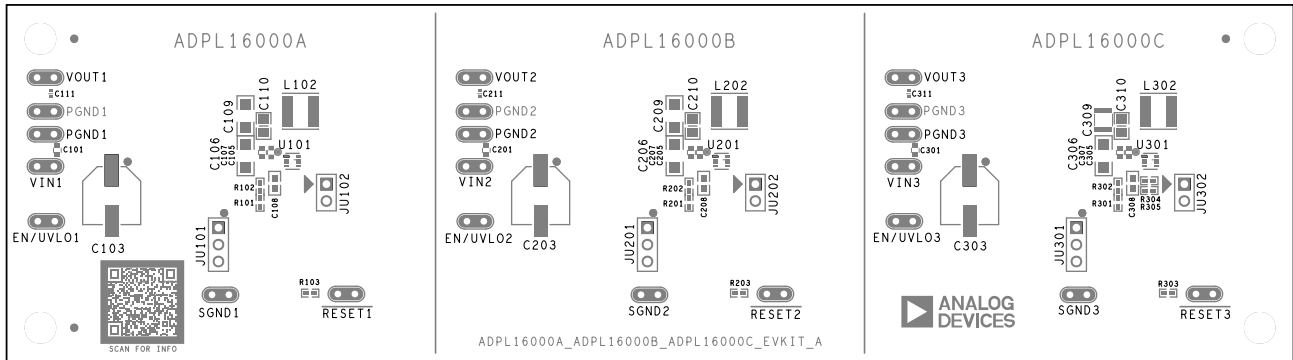

ADPL16000A/ADPL16000B/ADPL16000C EV Kits PCB Layout Diagram—Top Silkscreen

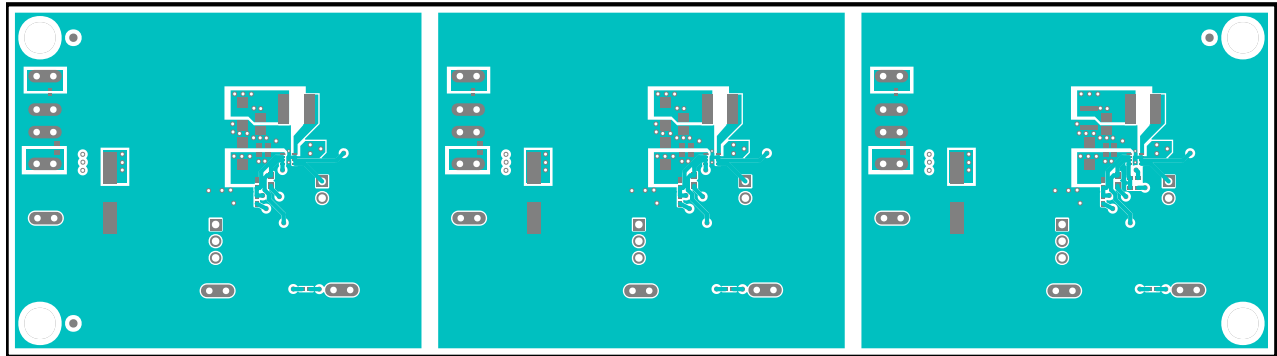

ADPL16000A/ADPL16000B/ADPL16000C EV Kits PCB Layout Diagram—Top Layer

ADPL16000A/ADPL16000B/ADPL16000C EV Kits PCB Layout Diagrams (Continued)

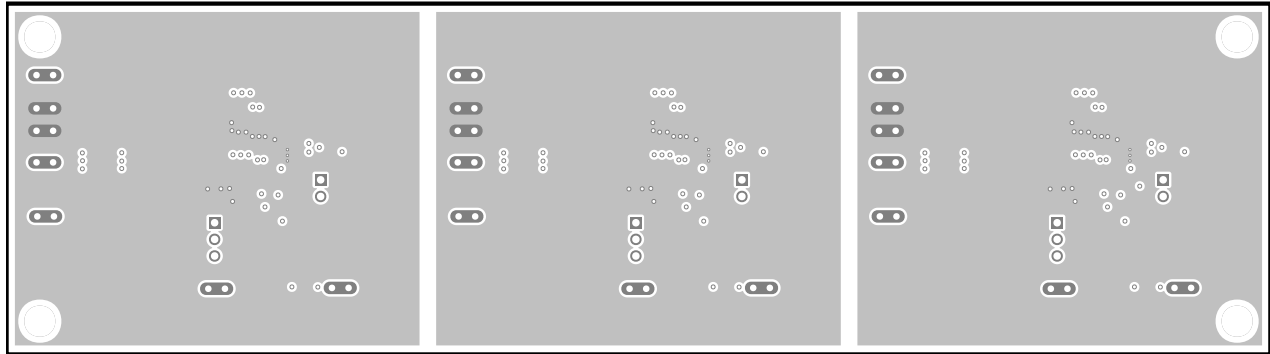

ADPL16000A/ADPL16000B/ADPL16000C EV Kits PCB Layout Diagram—Layer 2

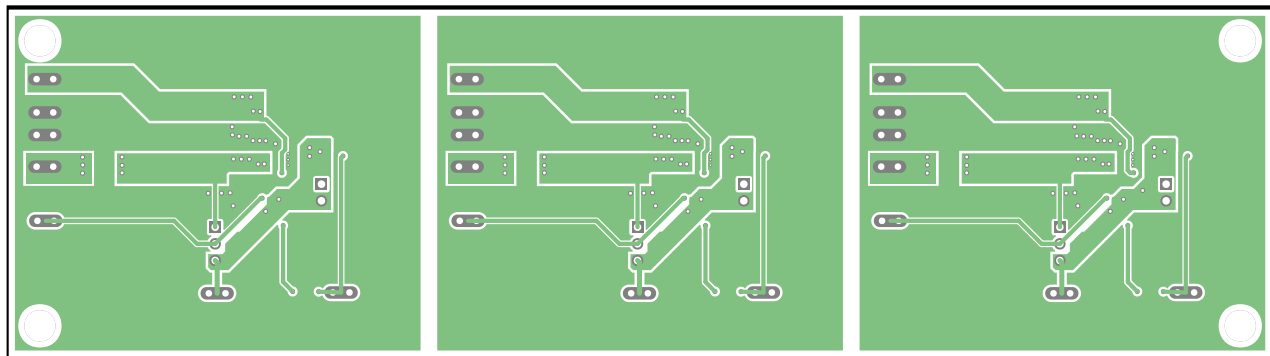

ADPL16000A/ADPL16000B/ADPL16000C EV Kits PCB Layout Diagram—Layer 3

ADPL16000A/ADPL16000B/ADPL16000C EV Kits PCB Layout Diagrams (Continued)

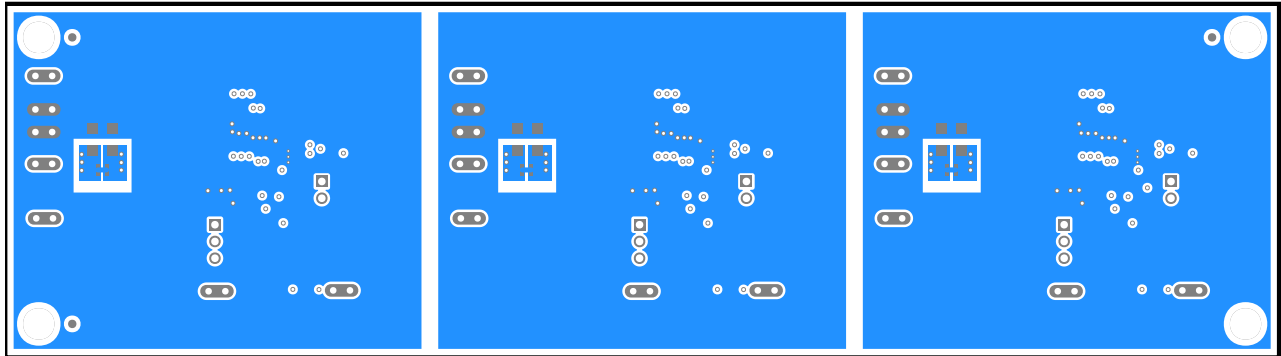

ADPL16000A/ADPL16000B/ADPL16000C EV Kits PCB Layout Diagram—Bottom Layer

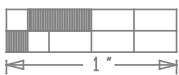
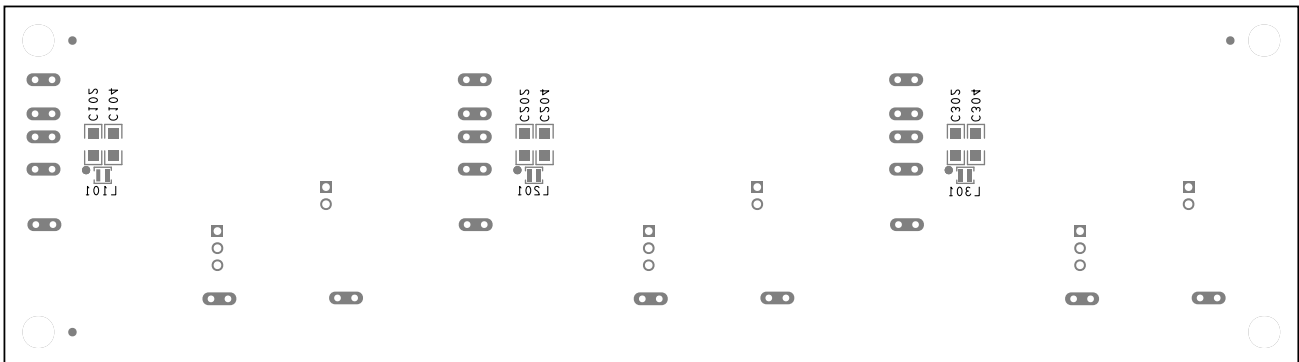

ADPL16000A/ADPL16000B/ADPL16000C EV Kits PCB Layout Diagram—Bottom Silkscreen

ADPL16000A/ADPL16000B/ ADPL16000C Evaluation Kits

Revision History

REVISION NUMBER	REVISION DATE	DESCRIPTION	PAGES CHANGED
0	03/24	Initial release	—

ADPL16000A/ADPL16000B/ ADPL16000C Evaluation Kits

Notes

ASSUMED BY ANALOG DEVICES FOR ITS USE, NOR FOR ANY INFRINGEMENTS OF PATENTS OR OTHER RIGHTS OF THIRD PARTIES THAT MAY RESULT FROM ITS USE. SPECIFICATIONS ARE SUBJECT TO CHANGE WITHOUT NOTICE. NO LICENCE, EITHER EXPRESSED OR IMPLIED, IS GRANTED UNDER ANY ADI PATENT RIGHT, COPYRIGHT, MASK WORK RIGHT, OR ANY OTHER ADI INTELLECTUAL PROPERTY RIGHT RELATING TO ANY COMBINATION, MACHINE, OR PROCESS WHICH ADI PRODUCTS ALL INFORMATION CONTAINED HEREIN IS PROVIDED "AS IS" WITHOUT REPRESENTATION OR WARRANTY. NO RESPONSIBILITY IS OR SERVICES ARE USED. TRADEMARKS AND REGISTERED TRADEMARKS ARE THE PROPERTY OF THEIR RESPECTIVE OWNERS.