

REVISION

A INITIAL DRAWING 02.02.2024

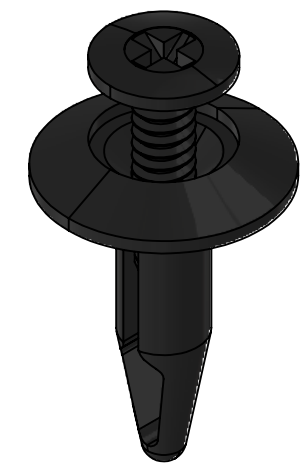

NOTES: DO NOT SCALE DRAWING
MOUNTING HOLE SIZE: Ø6.3
PANEL RANGE: 2.5 to 8.0

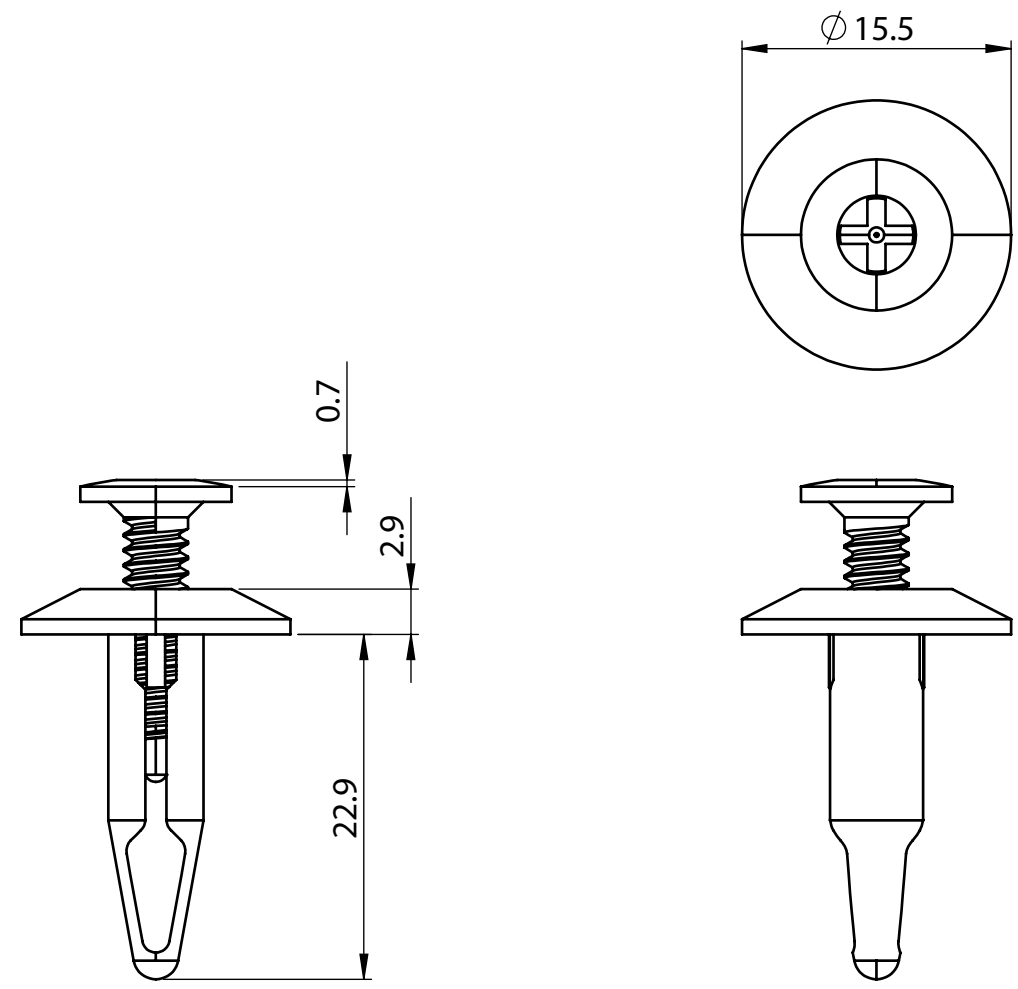

UNLESS OTHERWISE SPECIFIED:
DIMENSIONS ARE IN MM (MILLIMETERS).
TOLERANCES: L<=4: ±0.1
4 < L <=15: ±0.2
15 < L <=50: ±0.3
50 < L <=100: ±0.4

| | NAME | DATE |
|--------|-----------------|----------|
| DRAWN | Andrew Fletcher | 08.08.24 |
| CHK'D | | |
| APPV'D | | |

MATERIAL: NYLON 6,6

HEAT TREATMENT: N/A

TITLE: SCREW RIVET 6.3mm X 22.9mm

DESIGN RIGHT. TR FASTENINGS LTD, 2024
UNDER NO CIRCUMSTANCES MUST THIS DRAWING BE COPIED
OR DISCLOSED WITHOUT FIRST OBTAINING WRITTEN
AUTHORITY.

CUSTOMER PART NUMBER: N/A

FINISH/COLOUR: BLACK

PART NUMBER: RP0000383405

A4

