

1

2

3

4

5

6

7

8

A

B

C

D

E

F

REVISION

A INITIAL DRAWING 02.02.2024

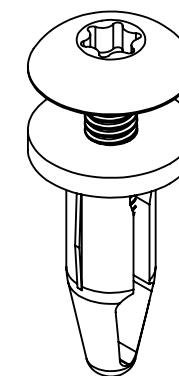
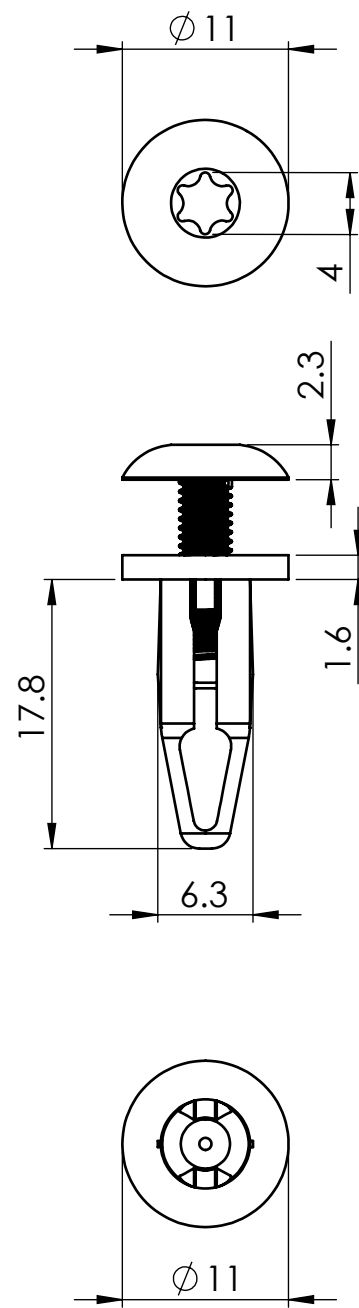

NOTES: DO NOT SCALE DRAWING

MOUNTING HOLE SIZE: Ø6.0

PANEL RANGE: 3.0 to 5.0



UNLESS OTHERWISE SPECIFIED:  
 DIMENSIONS ARE IN MM (MILLIMETERS).  
 TOLERANCES: L<=4: ±0.1  
 4 < L <=15: ±0.2  
 15 < L <=50: ±0.3  
 50 < L <=100: ±0.4

	NAME	DATE
DRAWN	Andrew Fletcher	08.08.24
CHK'D		
APPVD		

MATERIAL: NYLON 6,6

HEAT TREATMENT: N/A

TITLE: SCREW RIVET 6.0mm X 17.8mm

DESIGN RIGHT. TR FASTENINGS LTD, 2024  
 UNDER NO CIRCUMSTANCES MUST THIS DRAWING BE COPIED  
 OR DISCLOSED WITHOUT FIRST OBTAINING WRITTEN  
 AUTHORITY.

CUSTOMER PART NUMBER: N/A

FINISH/COLOUR: BLACK

PART NUMBER: RP0000383461

A4

PROJECTION

