

REVISION	
A	INITIAL DRAWING 02.02.2024

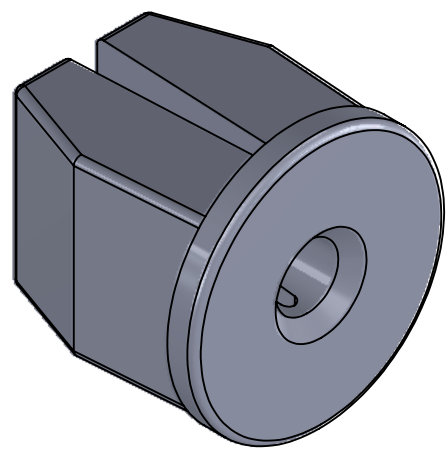
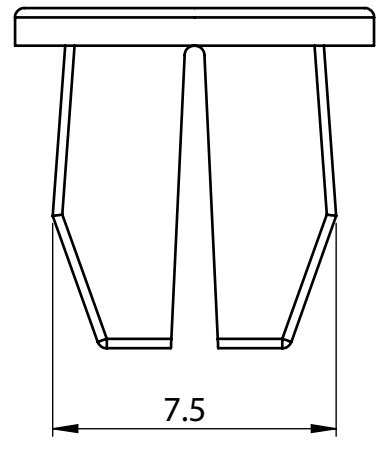
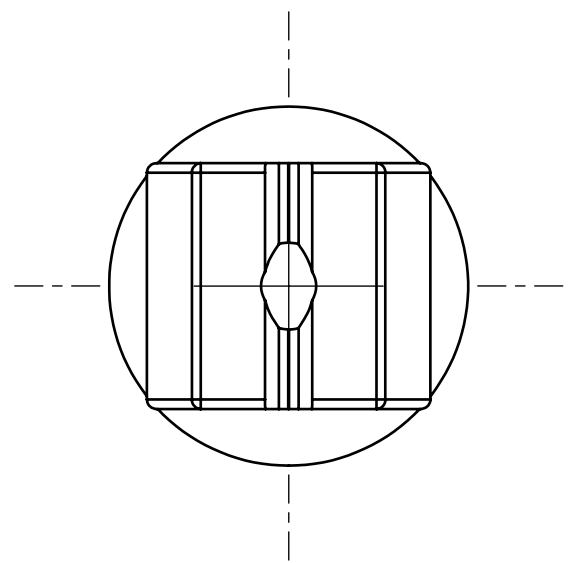
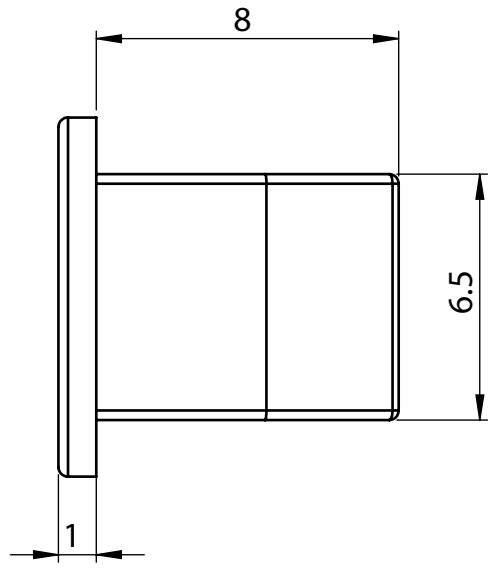
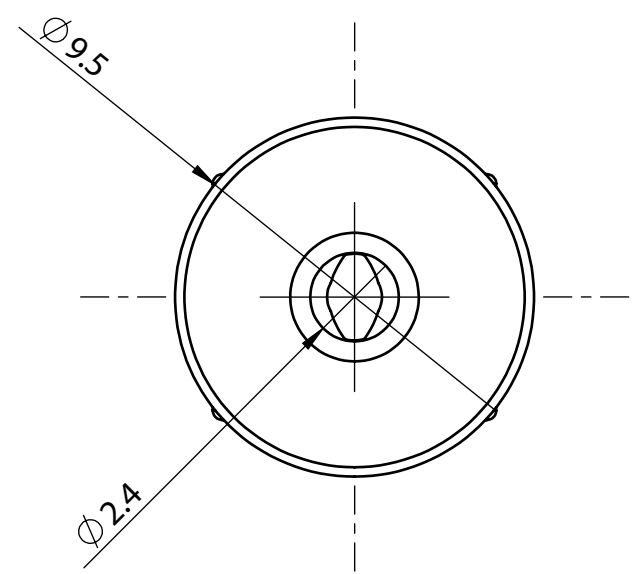

NOTES: DO NOT SCALE DRAWING  
 MOUNTING HOLE SIZE: 7.0mm SQ.  
 PANEL RANGE: 0.8 to 3.0  
 TO SUIT SCREW SIZE No. 8

UNLESS OTHERWISE SPECIFIED:  
 DIMENSIONS ARE IN MM (MILLIMETERS).  
 TOLERANCES: L<=4: ±0.1  
 4 < L <=15: ±0.2  
 15 < L <=50: ±0.3  
 50 < L <=100: ±0.4

NAME	DATE
DRAWN Andrew Fletcher	08.08.24
CHK'D	
APPVD	

MATERIAL: NYLON 6,6  
 HEAT TREATMENT: N/A

TITLE:  
 No 8 (0.8 - 3.0) Expansion Nut Rnd Grommet

DESIGN RIGHT. TR FASTENINGS LTD, 2024  
 UNDER NO CIRCUMSTANCES MUST THIS DRAWING BE COPIED  
 OR DISCLOSED WITHOUT FIRST OBTAINING WRITTEN  
 AUTHORITY.

CUSTOMER PART NUMBER: N/A

FINISH/COLOUR: NATURAL

PART NUMBER: RP0000383424

A4