

10G Base-T, SMD PoE LAN Isolation Transformer

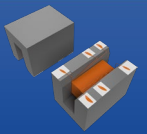

ALANC010G

Request Samples



Check Inventory



4.6 x 3.4 x 3.5 mm
RoHS/RoHS II Compliant
 MSL Level = 1

Features

- Uniform transformer windings
- Power over Ethernet (PoE, PoE+) capable.
- Meets IEEE 802.3ab and 802.3an standards
- Compatible with 10G BASE-T
- Symmetric Orientation
- Operating temperature range of -40°C to +85°C
- RoHS Compliant
- 1CT:1CT Transformer

Applications

- Fast and gigabit Ethernet
- Servers, switches and routers
- IP cameras, surveillance, and phone
- Access points
- Industrial computers and robotics
- Networking and communications
- Broadcast video
- Set top box

Electrical Specifications @25°C

Part Number*	Inductance (uH Min)	Interwinding Capacitance (pF Max)	DC Resistance (Ω Max)		Rated Current (mA)	Insertion Loss (dB Max)	Insertion Loss (dB Max)	Hi Pot (VAC)	Turn Ratio
			Pins 1-2	Pins 4-5					
Test Condition	@100kHz, 0.1V	@ 100KHz, 0.2V			Pins 1-2-6 Pins 5-4-3	1~200 MHz	400~500 MHz	1 sec.	1-2 : 4-5
ALANC010G1-EADT	120	25	1.5	1.5	300	-1.5	-2.0	1500	1CT:1CT
ALANC010G2-EADT	120	25	1.2	1.2	600	-1.5	-2.0	1500	1CT:1CT

*The “T” at the end of the part numbers refers to “Tape & Reel” packaging. For other options, please refer to the Part Identification section.

ALANC010G series is RoHS/ RoHS II Compliant and Pb free.

Moisture Sensitivity Level (MSL) – Level 1.

Applicable Standards: IEEE 802.3ab and 802.3an.

Operating Temperature: -40°C ~ +85°C.

Storage Condition: -40°C ~ +85°C (on board), 40%-60% RH.

ALANC002G1-EADT

Insertion Loss (dB)

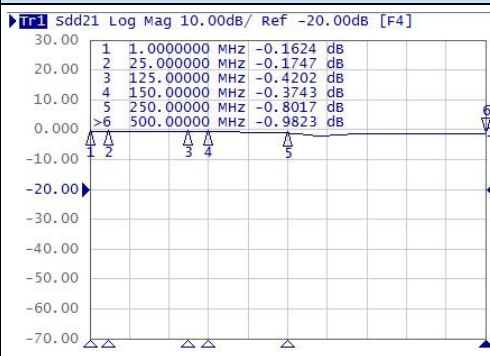

Return Loss (dB)



DCMR (dB)

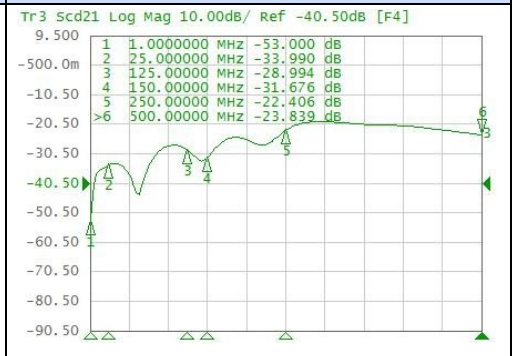

5101 Hidden Creek Ln, Spicewood TX 78669
 Phone: 512-371-6159 Fax: 512-351-8858
 For terms and conditions of sales, please visit:
www.abracon.com

REVISION Initial Release :
9/24/2024

ABRACON IS
 ISO9001-2015
 CERTIFIED

10G Base-T, SMD PoE LAN Isolation Transformer

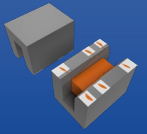

ALANC010G

Request Samples



Check Inventory



4.6 x 3.4 x 3.5 mm
RoHS/RoHS II Compliant
MSL Level = 1

ALANC002G1-EADT

Insertion Loss (dB)

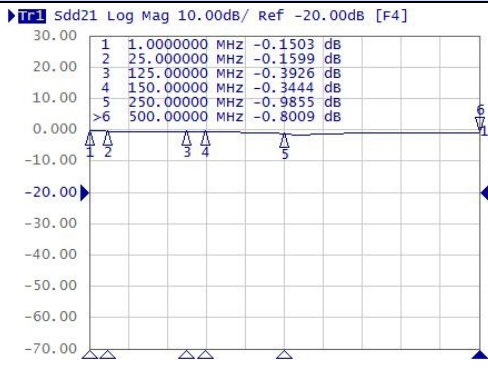

Return Loss (dB)

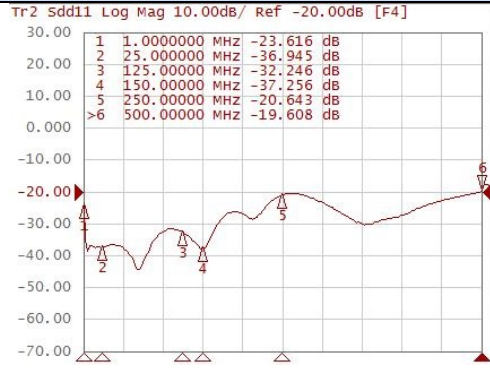

DCMR (dB)

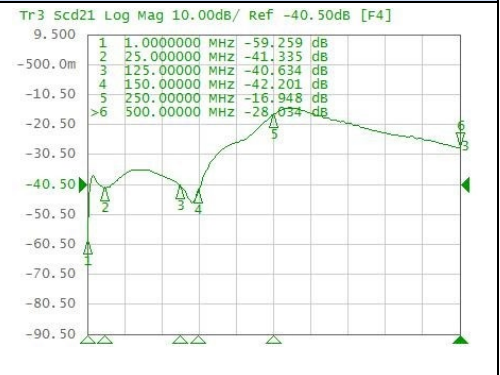

Part Identification

ALANC010G -

Power Over Ethernet
No PoE: 0
PoE: 1
PoE+: 2
PoE++: 3

Package
E: 6-pin

Schematic
A: Standard

Operating Temp.
D: -40°C ~ +85°C

Packaging
T: Tape & reel
B: Bulk



5101 Hidden Creek Ln, Spicewood TX 78669
 Phone: 512-371-6159 Fax: 512-351-8858
 For terms and conditions of sales, please visit:
www.abracon.com

REVISION Initial Release :
9/24/2024

ABRACON IS
 ISO9001-2015
 CERTIFIED

10G Base-T, SMD PoE LAN Isolation Transformer

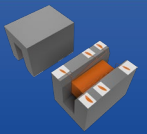

ALANC010G

Request Samples



Check Inventory



4.6 x 3.4 x 3.5 mm
RoHS/RoHS II Compliant
 MSL Level = 1

Mechanical Specifications

Package E: 6-pin

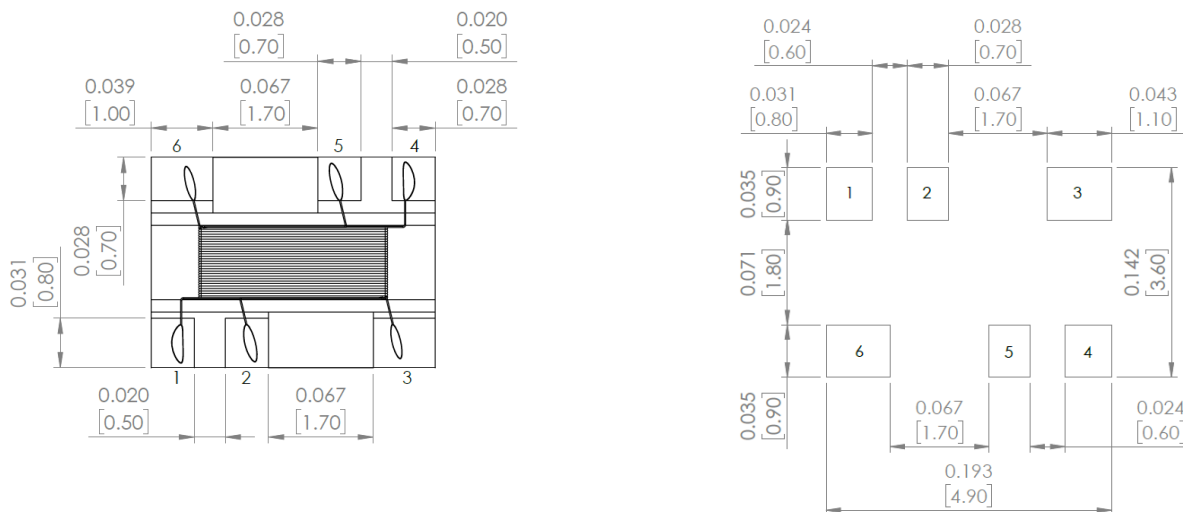
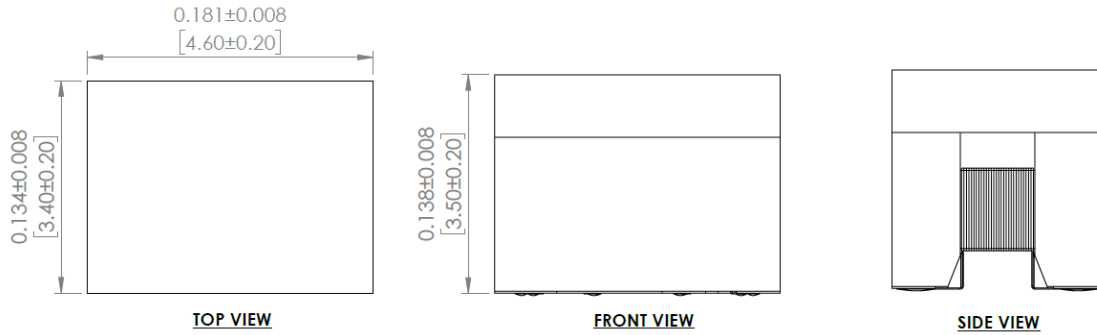

Dimensions unit: inches [mm]

Recommended Land Pattern

Schematic

A: Standard

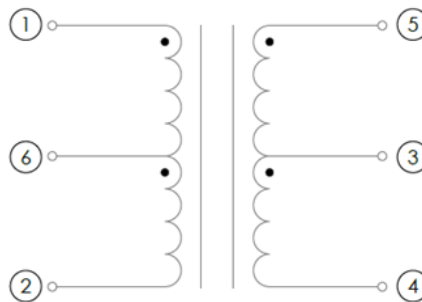

5101 Hidden Creek Ln, Spicewood TX 78669
 Phone: 512-371-6159 Fax: 512-351-8858
 For terms and conditions of sales, please visit:
www.abracon.com

REVISION Initial Release :
 9/24/2024

ABRACON IS
 ISO9001-2015
 CERTIFIED

10G Base-T, SMD PoE LAN Isolation Transformer

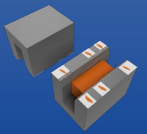

ALANC010G

Request Samples



Check Inventory



4.6 x 3.4 x 3.5 mm
RoHS/RoHS II Compliant
 MSL Level = 1

Reflow Profile

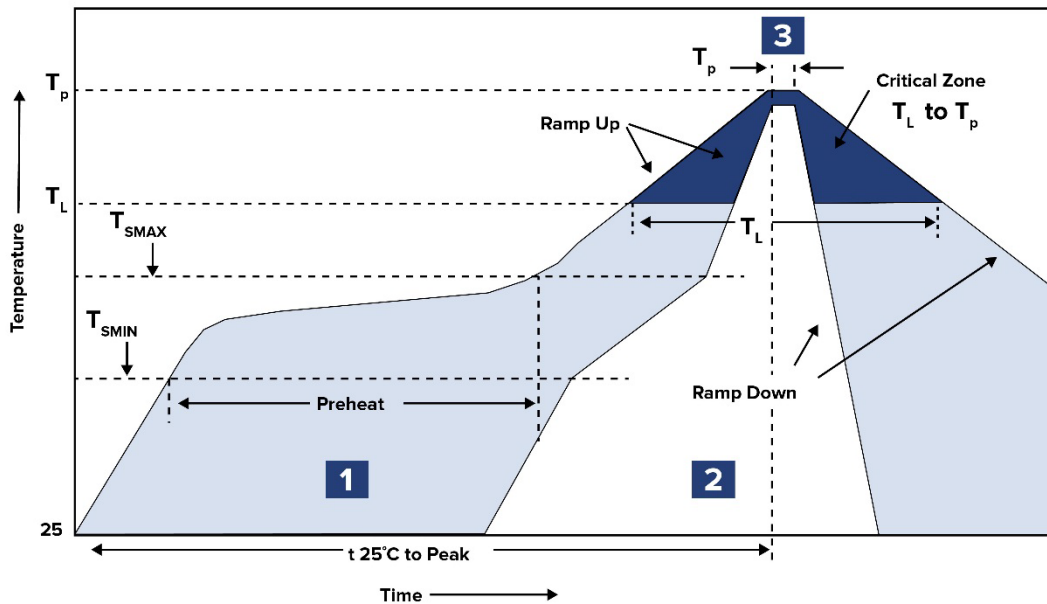

Zone	Description	Temperature	Times
1	Preheat	$T_{SMIN} \sim T_{SMAX}$ 150°C ~ 200°C	60 ~ 180 sec.
2	Reflow	T_L 217°C	60 ~ 150 sec.
3	Peak heat	T_P 260°C	10 sec. MAX

10G Base-T, SMD PoE LAN Isolation Transformer

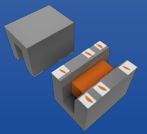

ALANC010G

Request Samples



Check Inventory



4.6 x 3.4 x 3.5 mm
RoHS/RoHS II Compliant
 MSL Level = 1

Packaging

Tape and Reel: 2,000 pcs/reel

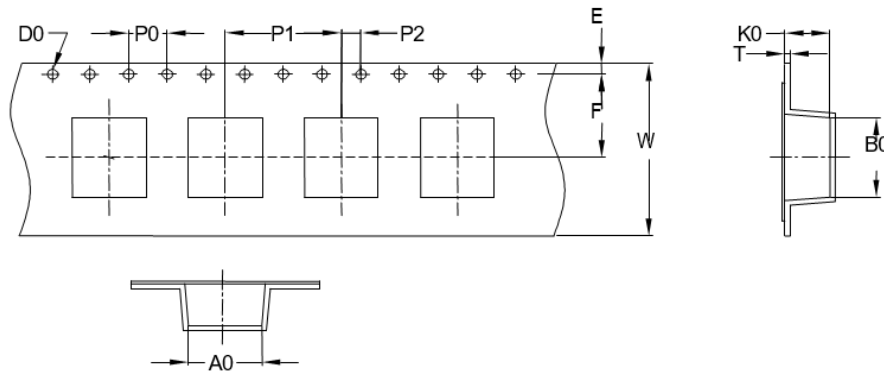

A0	B0	W	E	F	P0	P1	P2	D0	T	K0
3.60	4.90	12.00	1.75	5.50	4.00	8.00	2.00	1.50 ±0.05	0.40 ±0.05	3.0

Tolerance: ±0.1 (unless otherwise noted)

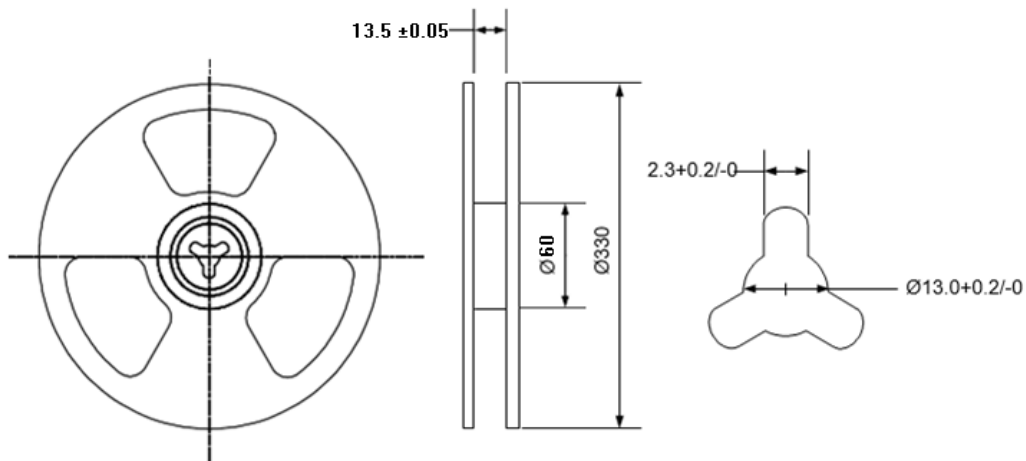

Dimensions unit: mm

ATTENTION: Abracon LLC's products are Commercial-Off-The-Shelf (COTS, which are designed, intended and validated for use in commercial, industrial and automotive applications. The customer is responsible for testing and verifying the performance of an Abracon solution to meet their system-level requirements.



5101 Hidden Creek Ln, Spicewood TX 78669
 Phone: 512-371-6159 Fax: 512-351-8858
 For terms and conditions of sales, please visit:
www.abracon.com

REVISION Initial Release :
9/24/2024

ABRACON IS
 ISO9001-2015
 CERTIFIED