

MDTR0290A-SPI	168 x 384	SPI Interface	TFT Module
Specification			
Version: 1		Date: 19/08/2023	
Revision			
1	17/08/2023	First issue	

Display Features			
Display Size	2.90"		
Resolution	168 x 384		
Orientation	Portrait		
Appearance	MONO		
Logic Voltage	2.8V		
Interface	SPI		
Brightness	Reflective		
Touchscreen	---		
Module Size	31.10 x 70.95 x 0.80 mm		
Operating Temperature	-20°C ~ +70°C		
Pinout	24 way FFC		
Pitch	0.50mm		
		Box Quantity	Weight / Display
		---	---

DESIGN • MANUFACTURE • SUPPLY

* - For full design functionality, please use this specification in conjunction with the ST7305 specification.(Provided Separately)

Display Accessories	
Part Number	Description
MDIB-CC1	Interconnect board for standard pitch pinouts to fine pitch wires. Providing pinouts for 2.54 pinout. 1.27, 1, 0.845, 0.8, 0.7, 0.65, 0.62, 0.6, 0.5 & 0.3 pads.

Optional Variants	
Appearances	Voltage



Basic Specifications

1. Display Specifications

MDTR0290A-SPI is a 168 x 384 dot-matrix mono reflective TFT LCD module.
This module is composed of a TFT LCD Panel, driver ICs and FPC.

2. Features

NO.	Item	Contents	Unit
1	LCD Size	2.9	inch
2	Display Mode	Mono TFT/ Normally White/ Reflective	-
3	Resolution	168(H) x 384(V)	pixels
4	Pixel pitch	0.1732(H) x 0.17408(V)	mm
5	Active area	29.1(H) x 66.85(V)	mm
6	Module size	31.1(H) x 70.95(V) x 0.8(D)	mm
7	Interface	4 Line SPI	-
8	Drive IC	ST7305	-
9	Operating Temp.	-20°C~ + 70°C	°C
10	Storage Temp.	-30°C~+ 80°C	°C
11	Weight	3.7	g

MIDAS
DISPLAYS

DESIGN • MANUFACTURE • SUPPLY



3. Mechanical Drawing

Item	Date	Remark
A	20220812	Original Drawing
B	20221221	膜的厚度改善为0.5mm

LCM NO	Pin Assignment
1	NC
2	NC
3	NC
4	NC
5	VCC (I-O)
6	NC
7	NC
8	NC
9	TE
10	LCD RES
11	LCD D/C
12	LCD GS
13	LCD SCLK
14	LCD SDI
15	IOVCC
16	VCI
17	GND
18	VGH
19	NC
20	VIV
21	AVDD
22	VNV
23	NC
24	VGL

接口支持：4线SPI

Customer Approval

Signature: _____

Unless Otherwise Specified		Title	
Unit	mm		
General Roughness	$\sqrt{0.4}$		
Tolerance	± 0.2	Drawn	E. E.
Dimension	± 1	Letter	Panel / E.
Angle	± 1	By	P. M.
		Date	20220812

NOTES:

- DISPLAY TYPE: 2.9" Mono TFT
- DISPLAY MODE: Normally White/Reflective Type
- DRIVER IC: ST7305
- OPERATING TEMP.: $-20^{\circ}\text{C} \sim 70^{\circ}\text{C}$
- STORAGE TEMP.: $-30^{\circ}\text{C} \sim 80^{\circ}\text{C}$
- UNMARKED TOLERANCE: ± 0.2
- 建议机壳开窗可视区比 LCD A.A区单边大 0.3mm
- 产品符合ROHS标准

4. Pin Definition

NO.	Symbol	I/O	Description
1	NC	-	No Connect.
2	NC	-	No Connect.
3	NC	-	No Connect.
4	NC	-	No Connect.
5	VCC(I-0)	P/O	VCC (I-0) is the power source of digital circuits.
6	NC	-	No Connect.
7	NC	-	No Connect.
8	NC	-	No Connect.
9	TE	O	Tearing effect signal is used to synchronize MCU to frame memory writing
10	LCD_RES	I	Reset input pin. When LCD_RES is "L", internal initialization procedure is executed
11	LCD_D/C	I	Display data/command selection pin in 4-line serial interface.
12	LCD_CS	I	Chip selection pin; Low enable, high disable.
13	LCD_SCLK	I	This pin is used to be serial interface clock
14	LCD_SDI	I/O	SPI interface input/output pin. The data is latched on the rising edge of the SCL signal.
15	IOVCC	P	Power Supply (Digital). IOVCC=1.65V-3.3V
16	VCI	P	Power Supply (Analog). VCI=2.55V-3.3V
17	GND	P	Power Ground
18	VGH	P/O	Power output(Positive) pin for gate driver
19	NC	-	No Connect.
20	VIV	P/O	Power output pin for analog driver.
21	AVDD	P/O	Power output pin for analog driver.
22	VNV	P/O	Power output pin for analog driver.
23	NC	-	No Connect.
24	VGL	P/O	Power output(Negative) pin for gate driver

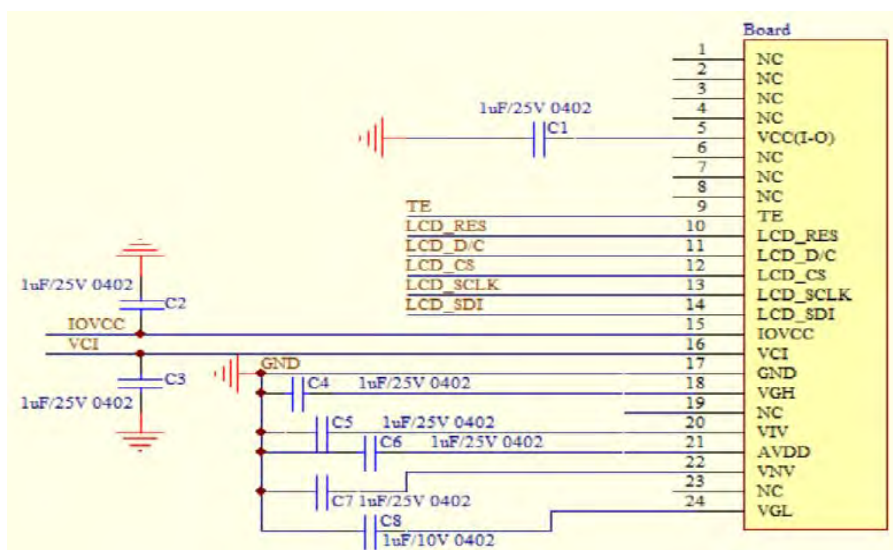

Absolute Maximum Ratings

Parameter	Symbol	Min	MAX	Unit	Notes
Supply Voltage (I/O)	IOVCC	-0.3	4.0	V	
Analog Supply Voltage	VCI	-0.3	4.0	V	
Logic Input Voltage	VIN	-0.3	IOVCC+0.5	V	
Operation Temperature	Top	-20	70	°C	
Storage Temperature	Tst	-30	80	°C	

MIDAS
DISPLAYS

DESIGN • MANUFACTURE • SUPPLY



Optics & Electrical Characteristics

1. Optics Characteristics

Item	Symbol	Measuring Conditions		Min.	Typ.	Max.	Unit	Remark
Viewing Angle	Θ	$\Phi = 0^\circ$	25 °C	-	65	-	Deg	Note1
		$\Phi = 180^\circ$	25 °C	-	65	-		
	Θ	$\Phi = 90^\circ$	25 °C	-	65	-		
		$\Phi = 270^\circ$	25 °C	-	65	-		
Reflectance	T%	--	-	-	45.06	-	%	
Contrast Ratio	CR	--	25 °C	-	15	-	--	Note2
Response Time	Tr+Tf	$\Theta = 0^\circ$ $\Phi = 0^\circ$	25 °C	-	-	-	ms	Note3
Color of CIE Coordinate	White	X	25 °C	--	-	--	--	BM-7A
		Y	25 °C		-			
	Red	X	25 °C		-			
		Y	25 °C		-			
	Green	X	25 °C		-			
		Y	25 °C		-			
	Blue	X	25 °C		-			
		Y	25 °C		-			

Note 1: Definition of Viewing Angle

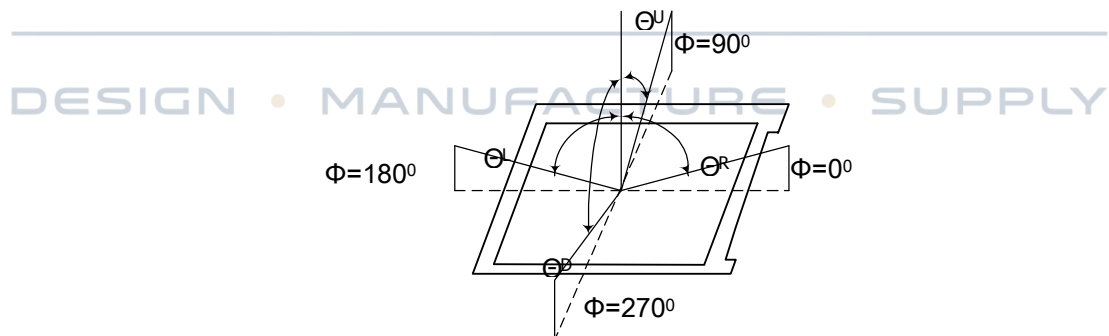

Note 2: Definition of Contrast Ratio (CR): measured at the center point of panel

CR = Luminance with all pixels white/Luminance with all pixels black

Note 3: Definition of Response Time: Sum of Tr and Tf :

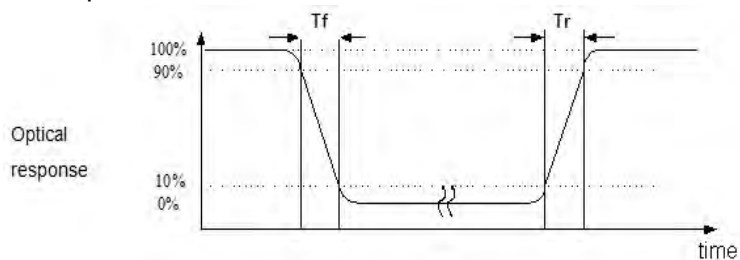

2. Operating Conditions

Parameter	Symbol	Min	TYP	MAX	Unit	Notes
System Voltage	VCI	2.55	2.8	3.3	V	
Interface Operation Voltage	IOVCC	1.65	1.8	3.3	V	
Gate Driver High Voltage	VGH	8	-	13.5	V	
Gate Driver Low Voltage	VGL	-10	-	-5	V	
Input voltage 'H' level	VIH	0.7IOVCC	-	IOVCC	V	
Input voltage 'L' level	VIL	GND	-	0.3IOVCC	V	
Output voltage 'H' level	VOH	0.8IOVCC	-	IOVCC	V	
Output voltage 'L' level	VOL	GND	-	0.2IOVCC	V	
Operating Current for VCI	I_{VCI}	-	14.3	-	μ A	Mean value for 1.8 sec (Refresh 1sec, Interval 0.8sec)
Operating Current for Panel	I_{panel}	-	25.7	-	μ A	Mean value for 1.8 sec (Refresh 1sec, Interval 0.8sec)

MIDAS
DISPLAYS

DESIGN • MANUFACTURE • SUPPLY



3. AC Characteristic

3.1 Serial Interface Characteristics (4-line serial):

Signal	Symbol	Parameter	Min	Max	Unit	Description
CSB	TCSS	Chip select setup time	10	-	ns	
	TCSH	Chip select hold time	10	-	ns	
SCL	TSCYCW	Serial clock cycle (Write)	30	-	ns	-write command & data
	TSHW	SCL "H" pulse width (Write)	15	-	ns	
	TSLW	SCL "L" pulse width (Write)	15	-	ns	
	TSCYCR	Serial clock cycle (Read)	150	-	ns	-read command & data
	TSHR	SCL "H" pulse width (Read)	60	-	ns	
	TSLR	SCL "L" pulse width (Read)	60	-	ns	
A0	TSAS	Address setup time	10	-	ns	
	TSAH	Address hold time	10	-	ns	
SDA(Write)	TSDS	Data setup time	10	-	ns	
	TSDH	Data hold time	10	-	ns	
SDA(Read)	TACC	Read data access time	10	50	ns	For maximum CL=30pF
	TOH	Read data output disable time	15	50	ns	For minimum CL=8pF

*IOVCC=1.8 to 3.3V, VCI=2.55 to 3.3V, GND=0V, Ta=25°C, (TR=TF<=15ns) using 20/80% of IOVCC as the reference.

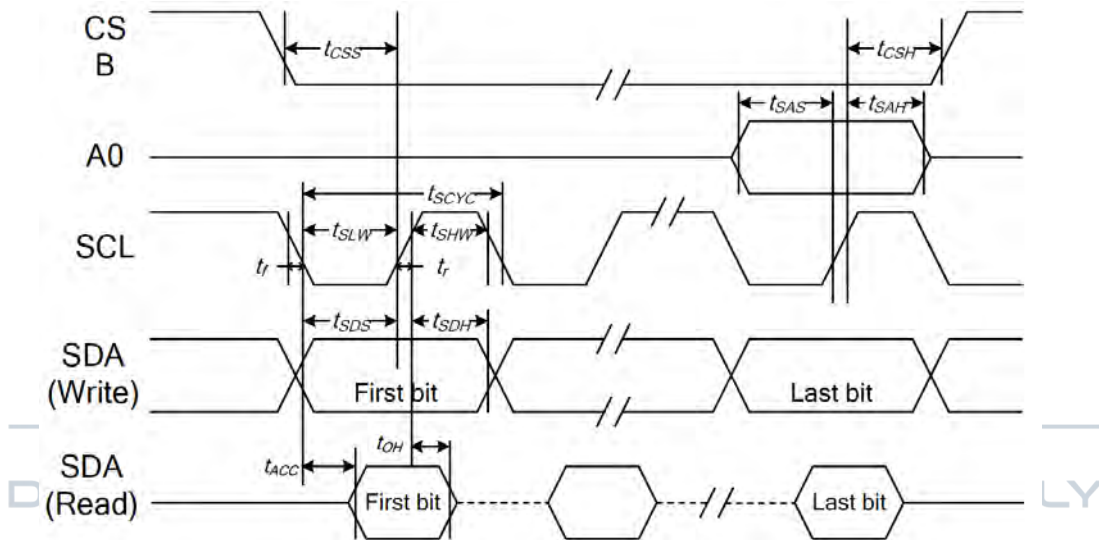

Reliability

1. Contents of Reliability Tests

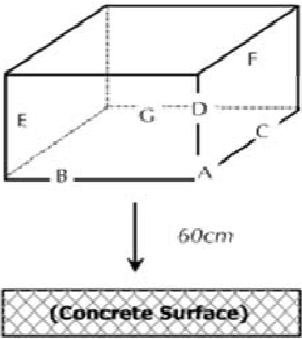
Item	Conditions	Criteria
High Temperature Operation	70±2°C, 120 hrs	The operational functions work.
Low Temperature Operation	-20±2°C, 120 hrs	
High Temperature Storage	80±2°C, 120 hrs	
Low Temperature Storage	-30±2°C, 120 hrs	
High Temperature/Humidity Operation	60±2°C, 90% RH, 120 hrs	
Thermal Shock	-10°C(30min)→25°C(5min)→60°C(30min)→25°C(5min)→-10°C(30min) 10 cycles.	
Vibration Test	Total fixed amplitude:1.5mm. Vibration Frequency:10~55Hz One cycle 60 seconds to 3 direction of X,Y,Z Each 15 minutes.	
ESD Test	Air Discharge: Apple ±4KV with 5 times.	
	Contact Discharge: Apple ±2KV with 5 times.	
Drop Test	<p>To be measured after dropping from 60cm high on the concrete surface in packing state.</p>  <p><i>Dropping method corner dropping:</i></p> <p><i>A corner: Once edge dropping.</i></p> <p><i>B, C, D edge: Once face dropping.</i></p> <p><i>E, F, G face: Once.</i></p>	

- * The samples used for the above tests include polarizer.
 - * No charge on display and in operation under the following test condition.
- Please note that the reliability test project requires the use of virgin samples

4.2 Failure Check Standard

After the completion of the described reliability test, the samples were left at room temperature for 2 hrs prior to conducting the failure test at 20±5°C; 65±5% RH.

Outgoing Quality Control Specifications

1. Environment Required

Customer's test & measurement are required to be conducted under the following conditions:

- Temperature: $20 \pm 5^{\circ}\text{C}$
- Humidity: $65 \pm 5\% \text{ RH}$
- Ambient Illumination:
 - Cosmetic Inspection: More than 600 Lux
 - Functional Inspection: 300~500 Lux
- View Angle:
 - Light-on Inspection Angle: $\pm 5^{\circ}$
 - Cosmetic Inspection Angle: $\pm 45^{\circ}$
- Distance between the Panel & Lamp: $\geq 50\text{cm}$
- Distance between the Panel & Eyes of the Inspector: $35 \pm 5\text{cm}$
- Finger glove (or finger cover) must be worn by the inspector.
- Inspection table or jig must be anti-electrostatic.

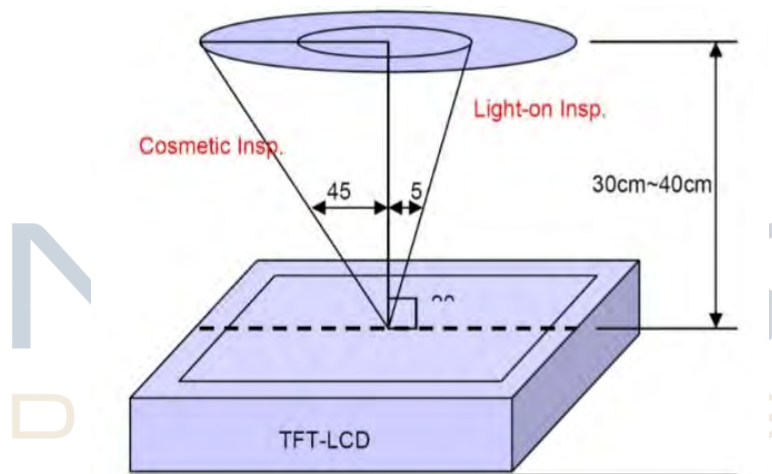

2. Sampling Plan

Level II, Normal Inspection, Single Sampling, MIL-STD-105E

3. Acceptable Quality Level

Partition	AQL	Definition
Major	0.65	Defects in Pattern Check (Display On)
Minor	1.5	Defects in Cosmetic Check (Display Off)

4. Inspection Criteria

4.1 Cosmetic Inspection (Panel):

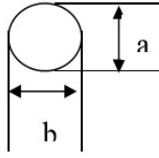
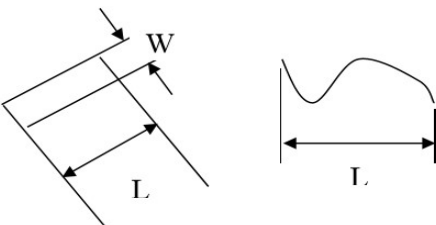
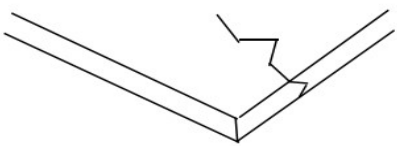
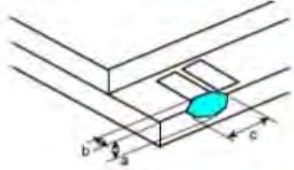
Check Item	Classification	Criteria(Unit: mm)																		
Black / White spot Foreign material (Round type) Pinholes Stain Particles inside cell.	Minor	 <table border="1" data-bbox="1029 347 1420 683"> <thead> <tr> <th>Size</th> <th>Area</th> <th>Acc. Qty</th> </tr> </thead> <tbody> <tr> <td>$\varphi \leq 0.10$</td> <td></td> <td>Ignore</td> </tr> <tr> <td>$0.10 < \varphi \leq 0.15$</td> <td></td> <td>2</td> </tr> <tr> <td>$0.15 < \varphi \leq 0.20$</td> <td></td> <td>1</td> </tr> <tr> <td>$0.20 < \varphi$</td> <td></td> <td>0</td> </tr> <tr> <td>Total</td> <td></td> <td>2 no include $\varphi \leq 0.10$</td> </tr> </tbody> </table> <p>$\varphi = (a + b) / 2$</p> <p>Distance between 2 defects should more than 5mm apart.</p>	Size	Area	Acc. Qty	$\varphi \leq 0.10$		Ignore	$0.10 < \varphi \leq 0.15$		2	$0.15 < \varphi \leq 0.20$		1	$0.20 < \varphi$		0	Total		2 no include $\varphi \leq 0.10$
Size	Area	Acc. Qty																		
$\varphi \leq 0.10$		Ignore																		
$0.10 < \varphi \leq 0.15$		2																		
$0.15 < \varphi \leq 0.20$		1																		
$0.20 < \varphi$		0																		
Total		2 no include $\varphi \leq 0.10$																		
Black and White line Scratch Foreign material (Line type)	Minor	 <table border="1" data-bbox="813 974 1332 1198"> <thead> <tr> <th>Length</th> <th>Width</th> <th>Acc. Qty</th> </tr> </thead> <tbody> <tr> <td>/</td> <td>$W \leq 0.03$</td> <td>Ignore</td> </tr> <tr> <td>$L \leq 2$</td> <td>$0.03 < W \leq 0.05$</td> <td>1</td> </tr> <tr> <td>/</td> <td>$0.05 < W$</td> <td>0</td> </tr> <tr> <td colspan="2">Total</td> <td>1</td> </tr> </tbody> </table> <p>Distance between 2 defects should more than 5mm apart.</p> <p>Scratches not viewable through the back of the display are acceptable.</p>	Length	Width	Acc. Qty	/	$W \leq 0.03$	Ignore	$L \leq 2$	$0.03 < W \leq 0.05$	1	/	$0.05 < W$	0	Total		1			
Length	Width	Acc. Qty																		
/	$W \leq 0.03$	Ignore																		
$L \leq 2$	$0.03 < W \leq 0.05$	1																		
/	$0.05 < W$	0																		
Total		1																		
Glass Crack	Minor	 <p>LCD with extensible crack line is unacceptable(When press the cracked LCD Area, the line will expand, we define it is extensible crack line)</p>																		
Glass Chipping Pad Area	Minor	 <table border="1" data-bbox="782 1780 1252 1870"> <thead> <tr> <th>Length and Width</th> <th>Acc. Qty</th> </tr> </thead> <tbody> <tr> <td>$c < 5.0, b < 0.4$</td> <td>Ignore</td> </tr> </tbody> </table>	Length and Width	Acc. Qty	$c < 5.0, b < 0.4$	Ignore														
Length and Width	Acc. Qty																			
$c < 5.0, b < 0.4$	Ignore																			



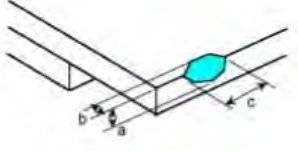
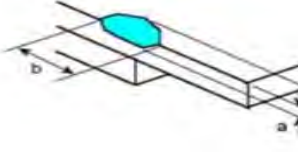
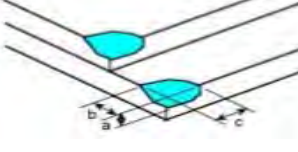
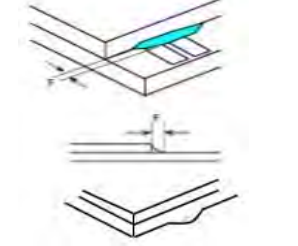

4.1 Cosmetic Inspection (Panel): Continued

Check Item	Classification	Criteria(Unit: mm)										
Glass Chipping Rear Of Pad Area	Minor	 <table border="1" data-bbox="762 481 1236 660"> <thead> <tr> <th>Length and Width</th> <th>Acc. Qty</th> </tr> </thead> <tbody> <tr> <td>$c > 3.0, b < 1.0$</td> <td>1</td> </tr> <tr> <td>$c < 3.0, b < 1.0$</td> <td>2</td> </tr> <tr> <td>$c < 3.0, b < 0.5$</td> <td>4</td> </tr> <tr> <td colspan="2">$a < \text{Glass Thickness}$</td> </tr> </tbody> </table>	Length and Width	Acc. Qty	$c > 3.0, b < 1.0$	1	$c < 3.0, b < 1.0$	2	$c < 3.0, b < 0.5$	4	$a < \text{Glass Thickness}$	
Length and Width	Acc. Qty											
$c > 3.0, b < 1.0$	1											
$c < 3.0, b < 1.0$	2											
$c < 3.0, b < 0.5$	4											
$a < \text{Glass Thickness}$												
Glass Chipping Except Pad Area	Minor	 <table border="1" data-bbox="762 875 1236 996"> <thead> <tr> <th>Length and Width</th> <th>Acc. Qty</th> </tr> </thead> <tbody> <tr> <td>$c \leq 0.6, b < 5.0$</td> <td>Ignore</td> </tr> <tr> <td colspan="2">$a < \text{Glass Thickness}$</td> </tr> </tbody> </table>	Length and Width	Acc. Qty	$c \leq 0.6, b < 5.0$	Ignore	$a < \text{Glass Thickness}$					
Length and Width	Acc. Qty											
$c \leq 0.6, b < 5.0$	Ignore											
$a < \text{Glass Thickness}$												
Glass Corner Chipping	Minor	 <table border="1" data-bbox="762 1189 1236 1323"> <thead> <tr> <th>Length and Width</th> <th>Acc. Qty</th> </tr> </thead> <tbody> <tr> <td>$c < 2.0, b < 1.5$</td> <td>Ignore</td> </tr> <tr> <td>$c < 1.5, b < 2$</td> <td>Ignore</td> </tr> <tr> <td colspan="2">$a < \text{Glass Thickness}$</td> </tr> </tbody> </table>	Length and Width	Acc. Qty	$c < 2.0, b < 1.5$	Ignore	$c < 1.5, b < 2$	Ignore	$a < \text{Glass Thickness}$			
Length and Width	Acc. Qty											
$c < 2.0, b < 1.5$	Ignore											
$c < 1.5, b < 2$	Ignore											
$a < \text{Glass Thickness}$												
Glass Burr	Minor	 <table border="1" data-bbox="762 1624 1236 1713"> <thead> <tr> <th>Length</th> <th>Acc. Qty</th> </tr> </thead> <tbody> <tr> <td>$F < 0.5$</td> <td>Ignore</td> </tr> </tbody> </table> <p data-bbox="751 1720 1476 1751">Glass burr don't affect assemble and module dimension.</p>	Length	Acc. Qty	$F < 0.5$	Ignore						
Length	Acc. Qty											
$F < 0.5$	Ignore											

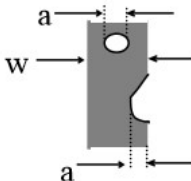

4.1 Cosmetic Inspection (Panel): Continued

Check Item	Classification	Criteria(Unit: mm)										
FPC Defect	Minor	 <p>1.Dent , pinhole width $a < W/2$. (W:circuitry width) 2.Open circuit is unacceptable. 3.No oxidation, contamination and distortion.</p>										
Bubble on Polarizer	Minor	<table border="1"> <thead> <tr> <th>Diameter</th> <th>Acc. Qty</th> </tr> </thead> <tbody> <tr> <td>$\varphi \leq 0.15$</td> <td>Ignore</td> </tr> <tr> <td>$0.15 < \varphi \leq 0.20$</td> <td>2</td> </tr> <tr> <td>$0.20 < \varphi \leq 0.30$</td> <td>1</td> </tr> <tr> <td>$0.3 < \varphi$</td> <td>None</td> </tr> </tbody> </table>	Diameter	Acc. Qty	$\varphi \leq 0.15$	Ignore	$0.15 < \varphi \leq 0.20$	2	$0.20 < \varphi \leq 0.30$	1	$0.3 < \varphi$	None
Diameter	Acc. Qty											
$\varphi \leq 0.15$	Ignore											
$0.15 < \varphi \leq 0.20$	2											
$0.20 < \varphi \leq 0.30$	1											
$0.3 < \varphi$	None											
Dent on Polarizer	Minor	<table border="1"> <thead> <tr> <th>Diameter</th> <th>Acc. Qty</th> </tr> </thead> <tbody> <tr> <td>$\varphi \leq 0.15$</td> <td>Ignore</td> </tr> <tr> <td>$0.15 < \varphi \leq 0.20$</td> <td>2</td> </tr> <tr> <td>$0.20 < \varphi \leq 0.30$</td> <td>1</td> </tr> <tr> <td>$0.3 < \varphi$</td> <td>None</td> </tr> </tbody> </table>	Diameter	Acc. Qty	$\varphi \leq 0.15$	Ignore	$0.15 < \varphi \leq 0.20$	2	$0.20 < \varphi \leq 0.30$	1	$0.3 < \varphi$	None
Diameter	Acc. Qty											
$\varphi \leq 0.15$	Ignore											
$0.15 < \varphi \leq 0.20$	2											
$0.20 < \varphi \leq 0.30$	1											
$0.3 < \varphi$	None											
Screen deformation	/	 <p>Test for insertion of plug gauge at highest warping point: $H \leq 0.25\text{mm}$ The client has special requirements, according to drawing.</p>										
Bezel	/	<ol style="list-style-type: none"> No rust, distortion on the Bezel. No visible fingerprints, stains or other contamination. 										
PCB	/	<ol style="list-style-type: none"> No distortion or contamination on PCB terminals. All components on PCB must same as documented on BOM/component layout. Follow IPC-A-600F. 										
Soldering	/	Follow IPC-A-610C standard.										

4.2 Light-on Inspection:

Check Item	Classification	Criteria
Electrical Defect	Major	The below defects must be rejected. <ol style="list-style-type: none"> Missing vertical / horizontal segment. Abnormal Display. No function or no display. Current exceeds product specifications. LCD viewing angle defect. Dark Dot - one Allowed. Bright Dot- one Allowed



Precautions When Using These TFT Display Modules

1. Handling Precautions

- 1) Since the display panel is being made of glass, do not apply mechanical impacts such as dropping from a high position.
- 2) If the display panel is broken by some accident and the internal organic substance leaks out, be careful not to inhale nor lick the organic substance.
- 3) If pressure is applied to the display surface or its neighborhood of the TFT display module, the cell structure may be damaged and be careful not to apply pressure to these sections.
- 4) The polarizer covering the surface of the TFT display module is soft and easily scratched. Please be careful when handling the TFT display module.
- 5) When the surface of the polarizer of the TFT display module has soil, clean the surface. It takes advantage of by using following adhesion tape.
 - * Scotch Mending Tape No. 810 or an equivalentNever try to breathe upon the soiled surface nor wipe the surface using cloth containing solvent such as ethyl alcohol, since the surface of the polarizer will become cloudy. Also, pay attention that the following liquid and solvent may spoil the polarizer:
 - * Water
 - * Ketone
 - * Aromatic Solvents
- 6) Hold OEL display module very carefully when placing TFT display module into the system housing. Do not apply excessive stress or pressure to TFT display module. And, do not over bend the film with electrode pattern layouts. These stresses will influence the display performance. Also, secure sufficient rigidity for the outer cases.

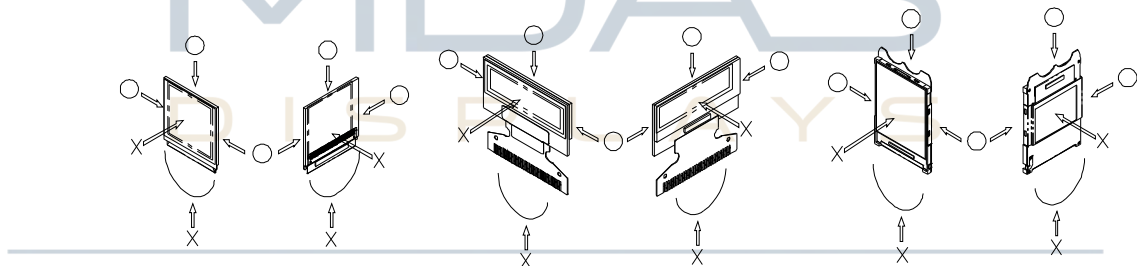

- 7) Do not apply stress to the driver IC and the surrounding molded sections.
- 8) Do not disassemble nor modify the TFT display module.
- 9) Do not apply input signals while the logic power is off.
- 10) Pay sufficient attention to the working environments when handling TFT display modules to prevent occurrence of element breakage accidents by static electricity.
 - * Be sure to make human body grounding when handling TFT display modules.
 - * Be sure to ground tools to use or assembly such as soldering irons.
 - * To suppress generation of static electricity, avoid carrying out assembly work under dry environments.
 - * Protective film is being applied to the surface of the display panel of the TFT display module. Be careful since static electricity may be generated when exfoliating the protective film.
- 11) Protection film is being applied to the surface of the display panel and removes the protection film before assembling it. At this time, if the TFT display module has been stored for a long period of time, residue adhesive material of the protection film may remain on the surface of the display panel after removed of the film. In such case, remove the residue material by the method introduced in the above Section 5).
- 12) If electric current is applied when the TFT display module is being dewed or when it is placed under high humidity environments, the electrodes may be corroded and be careful to avoid the above.

2. Storage Precautions

- 1) When storing TFT display modules, put them in static electricity preventive bags avoiding exposure to direct sun light nor to lights of fluorescent lamps. and, also, avoiding high temperature and high humidity environment or low temperature (less than 0°C) environments.
(We recommend you to store these modules in the packaged state when they were shipped from Midas Displays.)
At that time, be careful not to let water drops adhere to the packages or bags nor let dewing occur with them.
- 2) If electric current is applied when water drops are adhering to the surface of the TFT display module, when the TFT display module is being dewed or when it is placed under high humidity environments, the electrodes may be corroded and be careful about the above.

3. Designing Precautions

- 1) The absolute maximum ratings are the ratings which cannot be exceeded for TFT display module, and if these values are exceeded, panel damage may be happen.
- 2) To prevent occurrence of malfunctioning by noise, pay attention to satisfy the V_{IL} and V_{IH} specifications and, at the same time, to make the signal line cable as short as possible.
- 3) We recommend you to install excess current preventive unit (fuses, etc.) to the power circuit (V_{CI}).
(Recommend value: 0.5A)
- 4) Pay sufficient attention to avoid occurrence of mutual noise interference with the neighboring devices.
- 5) As for EMI, take necessary measures on the equipment side basically.
- 6) When fastening the TFT display module, fasten the external plastic housing section.
- 7) If power supply to the TFT display module is forcibly shut down by such errors as taking out the main battery while the TFT display panel is in operation, we cannot guarantee the quality of this TFT display module.
- 8) The electric potential to be connected to the rear face of the IC chip should be as follows: [ST7305](#)
* Connection (contact) to any other potential than the above may lead to rupture of the IC.

4. Precautions when disposing of the TFT display modules

- 1) Request the qualified companies to handle industrial wastes when disposing of the TFT display modules. Or, when burning them, be sure to observe the environmental and hygienic laws and regulations.

5. Other Precautions

- 1) When a TFT display module is operated for a long of time with fixed pattern may remain as an after image or slight contrast deviation may occur.
Nonetheless, if the operation is interrupted and left unused for a while, normal state can be restored. Also, there will be no problem in the reliability of the module.
- 2) To protect TFT display modules from performance drops by static electricity rapture, etc., do not touch the following sections whenever possible while handling the TFT display modules.
* Pins and electrodes
* Pattern layouts such as the COF & FPC
- 3) With this TFT display module, the TFT driver is being exposed. Generally speaking, semiconductor elements change their characteristics when light is radiated according to the principle of the solar battery. Consequently, if this TFT driver is exposed to light, malfunctioning may occur.
* Design the product and installation method so that the TFT driver may be shielded from light in actual usage.
* Design the product and installation method so that the TFT driver may be shielded from light during the inspection processes.
- 4) Although this TFT display module stores the operation state data by the commands and the indication data, when excessive external noise, etc. enters into the module, the internal status may be changed. It therefore is necessary to take appropriate measures to suppress noise generation or to protect from influences of noise on the system design.
- 5) We recommend you to construct its software to make periodical refreshment of the operation statuses (re-setting of the commands and re-transference of the display data) to cope with catastrophic noise.

