

Thick Film Power Resistor



FEATURES

- AEC-Q200 qualified
- Cold system without external radiation
- High power / volume ratio
- Cooled by auxiliary heatsink (not supplied)
- Non-inductive
- Pre-applied phase change thermal interface PC-TIM (optional)
- Internal temperature monitoring with a NTC thermistor (optional)
- Material categorization: for definitions of compliance please see www.vishay.com/doc?99912

RoHS
COMPLIANT

LINKS TO ADDITIONAL RESOURCES



APPLICATIONS

- Automotive: precharge, discharge, and active discharge
- Industrial and AMS: power conversion and snubber

STANDARD ELECTRICAL SPECIFICATIONS

MODEL	RESISTANCE RANGE Ω	MAX. RATED POWER $BC_{85^{\circ}C}$ W	TOLERANCE ⁽¹⁾ \pm %	TEMPERATURE COEFFICIENT \pm ppm/ $^{\circ}C$	E-SERIES OHMIC VALUES
ISOA	10 to 220	200	10, 5	150	E24
	220 to 1M	200	10, 5	100	E24

Note

⁽¹⁾ ± 2 % or ± 1 % on special request for limited resistance value and with reduction of maximum power and pulse rating (contact us for details)

MECHANICAL SPECIFICATIONS

UL 94 flame classifications	Housing and potting materials comply with UL 94 V-0 standard
Resistive element	Cermet
Substrate	Alumina
Encapsulation	Resin filled case

TECHNICAL SPECIFICATIONS

PARAMETER	ISOA200
Nominal power at 85 $^{\circ}C$ bottom case temperature	200 W
Operating temperature range	-55 $^{\circ}C$ to +150 $^{\circ}C$
Maximum operating voltage	1500 V
Dielectric strength with all terminals connected as one pole	4000 V_{RMS} (50 Hz / 1 min)
Dielectric strength power resistor to NTC resistor	1500 V_{RMS} (50 Hz / 1 min)
CTI	> 600
Creepage distance	> 4.2 mm
Clearance distance	> 3.6 mm
Insulation	$\geq 10 G\Omega$ at 1000 V_{DC}
Inductance	≤ 50 nH
NTC characteristics (option)	Vishay NTCS0603E3103FLT www.vishay.com/ppg?29056
Weight (max.)	< 16 g



PERFORMANCES (AEC-Q200 Revision E Qualification Type Tests)		
TESTS	CONDITIONS	REQUIREMENTS
High temperature exposure	MIL-STD-202 method 108 Condition: 1000 h at T = 155 °C. Unpowered	$\leq \pm (2 \% + 0.1 \Omega)$
Temperature cycling	JESD22 method JA-104 1000 cycles (-55 °C to +125 °C)	$\leq \pm (2 \% + 0.1 \Omega)$
Biased humidity	MIL-STD-202 method 103 Condition: 1000 h 85 °C / 85 % RH	$\leq \pm (5 \% + 0.1 \Omega)$
Operational life	MIL-STD-202 method 108 Condition: D steady state $T_A = 85 \text{ °C}$ of bottom case at rated power 200 W 90' On / 30' off / 1000 h	$\leq \pm (2 \% + 0.1 \Omega)$
ESD	AEC-Q200-002 Condition: 6 kV to 25 kV	$\leq \pm (0.5 \% + 0.05 \Omega)$
Vibration	MIL-STD-202 method 204 Condition B: 10 g's for 20 min for 1 cycle, 12 cycles each of 3 orientations (total of 36). Test from 10 Hz to 2000 Hz	$\leq \pm (0.5 \% + 0.05 \Omega)$
Mechanical shock	MIL-STD-202 method 213 Fig. 1 Condition C: 100 g's/6 ms 3.75 m/s 3 shock/direction, 2 directions along 3 axes (18 shocks)	$\leq \pm (0.5 \% + 0.05 \Omega)$
Terminal strength (lead)	MIL-STD-202 method 211 Test lead device lead integrity only. Conditions: A (2.27 kg)	$\leq \pm (0.5 \% + 0.05 \Omega)$

Note

- All tests were done in Vishay MCB laboratories conditions

RESISTANCE VALUE VS. TEMPERATURE FOR NTC0603E3103FLT

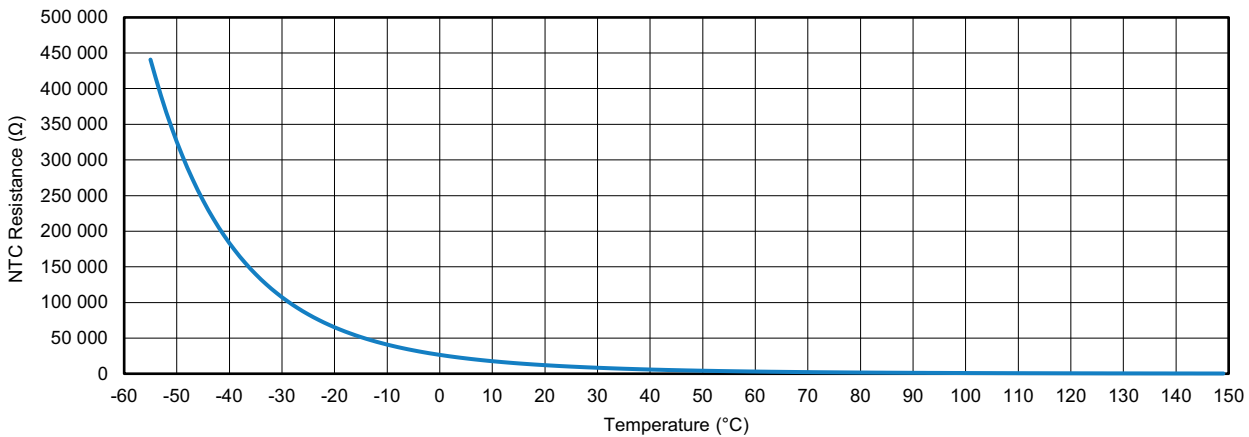



PULSE ENERGY

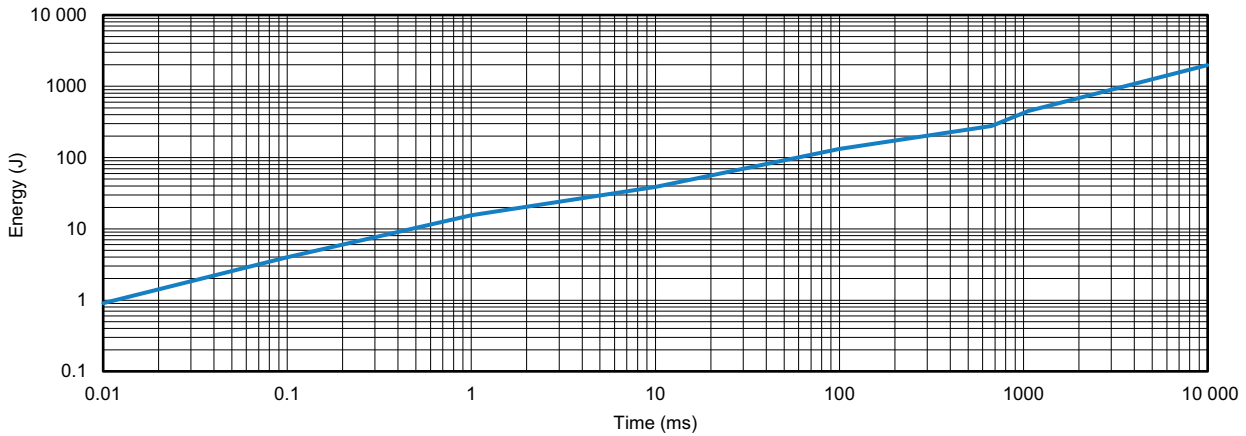

POWER DISSIPATION

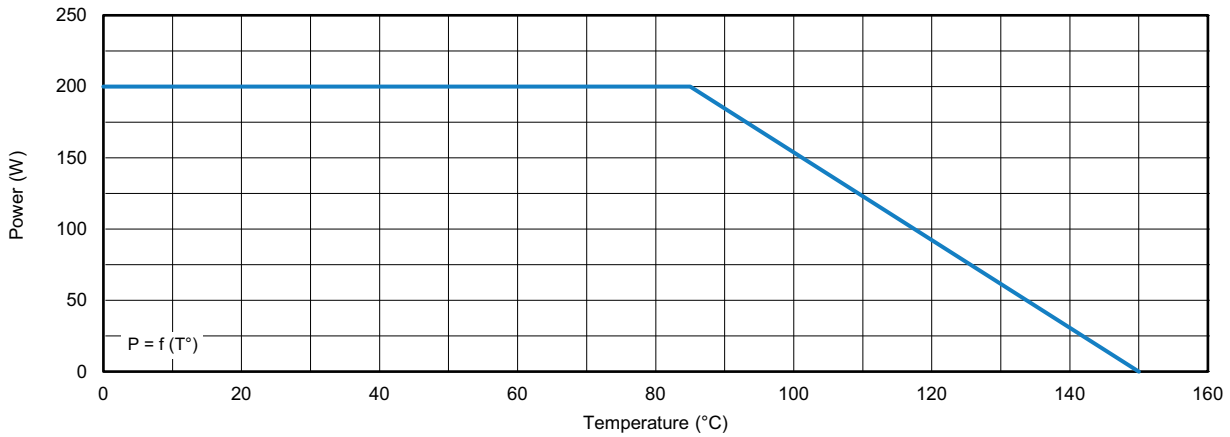

Permanent applicable power (W) as a function of bottom case temperature (°C)

POWER VS. TIME

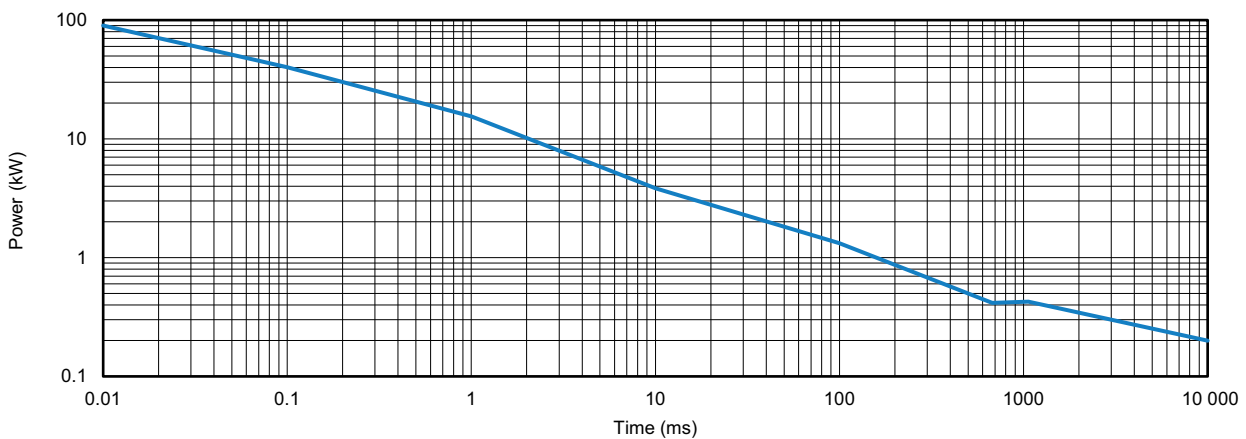

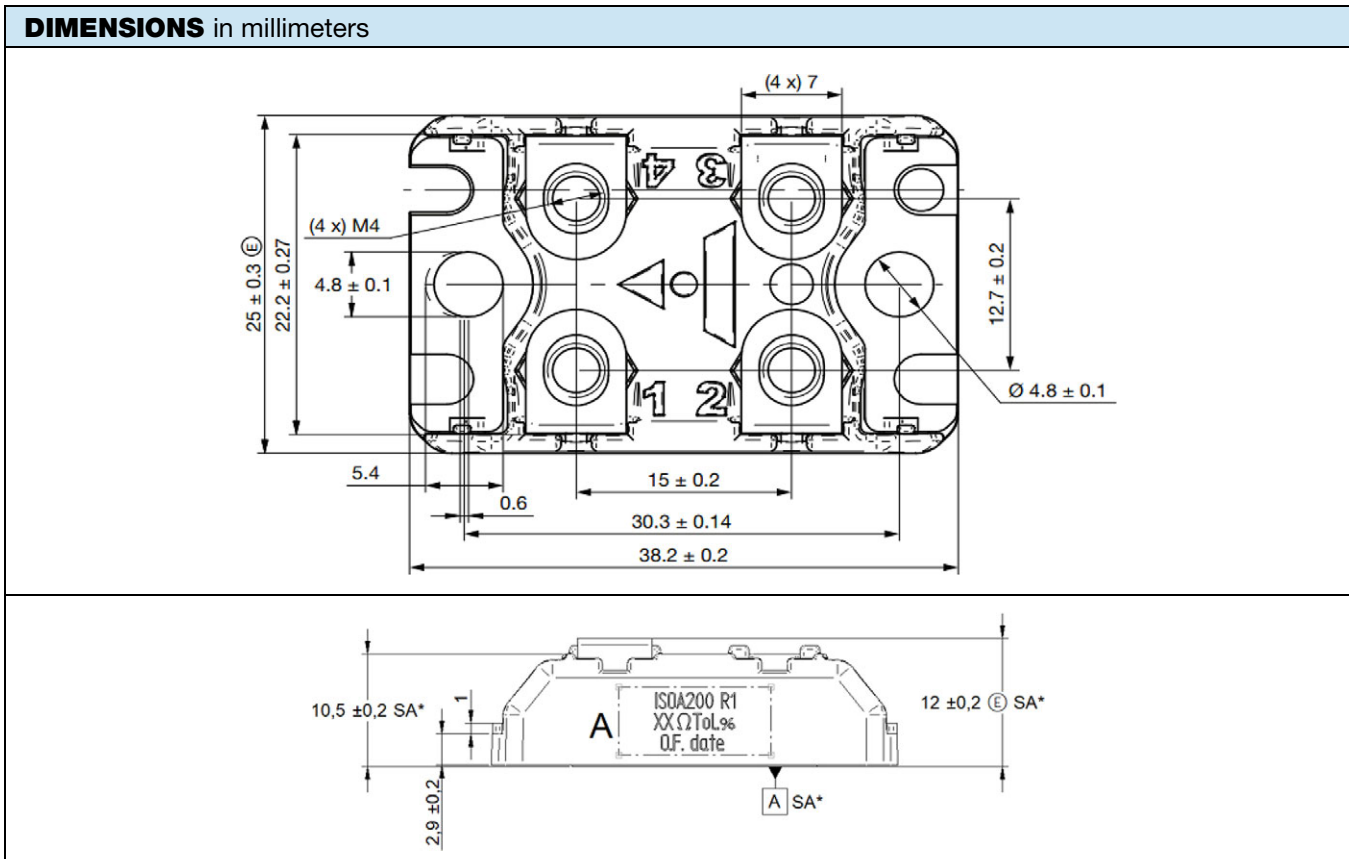

Note

(1) SA: under alumina

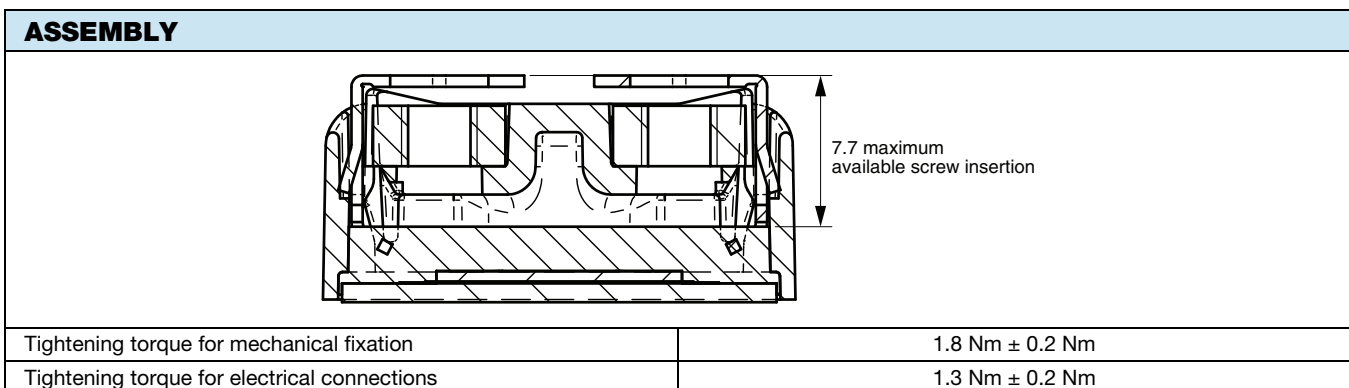
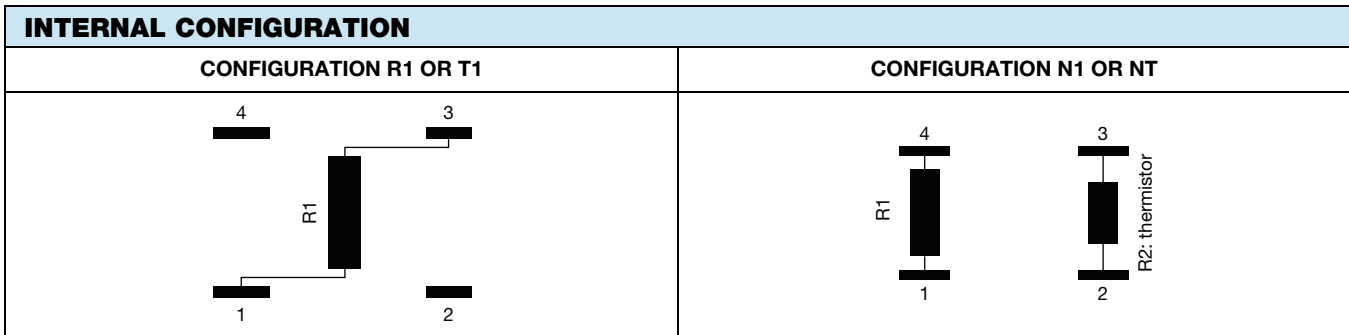



STORAGE CONDITIONS

Parts shall be stored in a dry place from 0 °C to +40 °C at 80 % RH maximum.

COOLING

The temperature of the heatsink may be maintained at the specified values with:

- Forced air ventilation or internal circulation of a liquid cooling
- Heatsink contact surface: < Ra 6.3 μ
- Evenness defect: 0.05 mm / 50 mm and 0.025 mm / 25 mm
- Surface temperature gradient (isotherm): 20 °C max.
- Thermal compound not supplied (resistance < 0.025 °C / W / 0.05 mm preconized)
- For mounting recommendations please contact wmcfixedresistors@vishay.com

Note

- The user must select the thermal resistance of the heatsink according to the power applied

ORDERING INFORMATION						
ISOA	200	R1	200	5 %	XXX	TU10
MODEL	STYLE	CONFIGURATION	RESISTANCE VALUE	TOLERANCE	CUSTOM DESIGN	PACKAGING
		Single resistor or Resistor and NTC		± 5 % ± 10 % Other on request		

GLOBAL PART NUMBER INFORMATION																	
I	S	O	A	2	0	0	R	1	2	0	0	0	J	T	X	X	X
1				2			3		4				5		6		7
1	2	3					4				5	6	7				
TYPE	POWER	OPTIONS					OHMIC VALUE				TOLERANCE	PACKAGING	INDUSTRIALIZATION NUMBER				
ISOA	200 = 200 W	R1: 1 resistor only N1: 1 resistor and NTC T1: 1 resistor and TIM NT: 1 resistor and NTC and TIM					The first three digits are significant figures and the last specifies the number of zeros to follow, R designates decimal point. 1301 = 1300 Ω				J = 5 % K = 10 % A = other on request	T = tube 10 pieces	3 specific digits (if applicable)				