

ICM-45605 HIGHLIGHTS

The ICM-45605 is a high performance 6-axis MEMS MotionTracking device. It has a configurable host interface that supports I3CSM, I²C and SPI serial communication, and an I²C master mode interface for connection to external sensors. The device features up to 8Kbytes FIFO and 2 programmable interrupts.

The ICM-45605 supports the lowest gyro and accel sensor noise in this IMU class, and has the highest stability against temperature, shock (up to 20,000g) or SMT/bend induced offset as well as immunity against out-of-band vibration induced noise. Other industry-leading features include InvenSense on-chip APEX Motion Processing engine for gesture recognition, activity classification, and pedometer, along with programmable digital filters, and an embedded temperature sensor.

FEATURES

- Gyroscope Noise: 3.8 mdps/√Hz & Accelerometer Noise: 70 μg/√Hz
 - Low-Noise mode 6-axis current consumption of 0.42 mA at 1600Hz
- User selectable Gyro Full-scale range (dps): ±15.625/±31.25/±62.5/±125/±250/±500/±1000/±2000
- User selectable Accelerometer Full-scale range (g): ±2/±4/±8/±16
- User configurable internal pull-up/pull-downs included on I/O interfaces to reduce system costs associated with external pull-ups/pull-downs
- User configurable Output Data Rate (ODR) and FIFO Data Rate (FDR)
- User-programmable digital filters for gyro, accel, and temp sensor
- APEX Motion Functions:
 - Pedometer, Tilt Detection, Single/Double Tap Detection, Raise to Wake, Wake on Motion
 - Free-Fall Detection, Significant Motion Detection, Low-G Detection, High-G Detection
- Host interface: 12.9 MHz I3CSM, 1 MHz I²C, 24 MHz SPI

APPLICATIONS

- Game Controllers, Cameras, IoT, Drones, Non-OIS Smartphones, Wearables, Hearables

BLOCK DIAGRAM



ORDERING INFORMATION

PART	TEMP RANGE	PACKAGE
ICM-45605†	-40°C to +85°C	2.5x3mm 14-Pin LGA

† Denotes RoHS and Green-Compliant Package

TABLE OF CONTENTS

	ICM-45605 Highlights	1
	Features.....	1
	Applications	1
	Block Diagram.....	1
	Ordering Information	1
1	Introduction.....	14
	1.1 Purpose and Scope	14
	1.2 Product Overview	14
	1.3 Applications	14
2	Features.....	15
	2.1 Gyroscope Features	15
	2.2 Accelerometer Features	15
	2.3 Motion Features	15
	2.4 Additional Features.....	16
3	Electrical Characteristics.....	17
	3.1 Gyroscope Specifications	17
	3.2 Accelerometer Specifications	18
	3.3 Electrical Specifications	19
	3.4 I ² C Timing Characterization	21
	3.5 SPI Timing Characterization – 4-Wire SPI Mode	23
	3.6 SPI Timing Characterization – 3-Wire SPI Mode	24
	3.7 Absolute Maximum Ratings.....	25
4	Applications Information.....	26
	4.1 Pin Out Diagram and Signal Description	26
	4.2 Typical Operating Circuit (Dual Interface I ² C Master Mode)	29
	4.3 Typical Operating Circuit (Single Interface Mode).....	30
	4.4 Bill of Materials for External Components.....	31
	4.5 System Block Diagram	32
	4.6 Overview.....	32
	4.7 Three-Axis MEMS Gyroscope with 16-bit ADCs and Signal Conditioning	33
	4.8 Three-Axis MEMS Accelerometer with 16-bit ADCs and Signal Conditioning	33
	4.9 I3C SM , I ² C and SPI Host Interface.....	33
	4.10 I ² C Master Interface for Connection To External Sensors	33
	4.11 Self-Test.....	33
	4.12 Clocking	34
	4.13 Sensor Data Registers.....	34

4.14	Interrupts.....	34
4.15	Digital-Output Temperature Sensor	34
4.16	Bias and LDOs	34
4.17	Charge Pump	34
4.18	Standard Power Modes	35
5	Signal Path	36
6	FIFO.....	37
6.1	Packet Structure	37
6.2	FIFO Header	38
7	Programmable Interrupts.....	40
8	EDMP	41
9	APEX Motion Functions	42
10	Digital Interface	43
10.1	I3C SM , I ² C and SPI Serial Interfaces	43
10.2	I3C SM Interface	43
10.3	I ² C Interface	46
10.4	I ² C Master Interface	46
10.5	SPI Interface	47
11	Assembly.....	48
11.1	Orientation of Axes	48
11.2	Package Dimensions.....	49
12	Device Package In Tape And Reel.....	51
13	Part Number Package Marking.....	52
14	Indirect Register Access.....	53
14.1	Host Indirect Access Register (IREG)	53
14.2	General Rules for Accessing IREG	53
14.3	Minimum Wait Time-Gap	53
14.4	IREG Write	53
14.5	IREG READ	54
15	Device Configuration for Data Endianness.....	55
16	Register Map	56
16.1	User Bank 0 Register Map	56
16.2	User Bank IMEM_SRAM Register Map	58
16.3	User Bank IPREG_BAR Register Map	61
16.4	User Bank IPREG_TOP1 Register Map	61
16.5	User Bank IPREG_SYS1 Register Map	63
16.6	User Bank IPREG_SYS2 Register Map	63

17	User Bank 0 Register Map – Descriptions.....	64
17.1	ACCEL_DATA_X1_UI	64
17.2	ACCEL_DATA_X0_UI	64
17.3	ACCEL_DATA_Y1_UI	64
17.4	ACCEL_DATA_Y0_UI	64
17.5	ACCEL_DATA_Z1_UI	64
17.6	ACCEL_DATA_Z0_UI	65
17.7	GYRO_DATA_X1_UI	65
17.8	GYRO_DATA_X0_UI	65
17.9	GYRO_DATA_Y1_UI	65
17.10	GYRO_DATA_Y0_UI	65
17.11	GYRO_DATA_Z1_UI	66
17.12	GYRO_DATA_Z0_UI	66
17.13	TEMP_DATA1_UI	66
17.14	TEMP_DATA0_UI	66
17.15	TMST_FSYNCH	67
17.16	TMST_FSYNCL	67
17.17	PWR_MGMT0	67
17.18	FIFO_COUNT_0	68
17.19	FIFO_COUNT_1	68
17.20	FIFO_DATA	68
17.21	INT1_CONFIG0	69
17.22	INT1_CONFIG1	71
17.23	INT1_CONFIG2	72
17.24	INT1_STATUS0	73
17.25	INT1_STATUS1	74
17.26	ACCEL_CONFIG0	75
17.27	GYRO_CONFIG0	76
17.28	FIFO_CONFIG0	77
17.29	FIFO_CONFIG1_0	77
17.30	FIFO_CONFIG1_1	78
17.31	FIFO_CONFIG2	78
17.32	FIFO_CONFIG3	79
17.33	FIFO_CONFIG4	80
17.34	TMST_WOM_CONFIG	81
17.35	FSYNC_CONFIG0	82
17.36	DMP_EXT_SEN_ODR_CFG	83

17.37	ODR_DECIMATE_CONFIG	84
17.38	EDMP_APEX_EN0	85
17.39	EDMP_APEX_EN1	85
17.40	APEX_BUFFER_MGMT	86
17.41	INTF_CONFIG0	87
17.42	INTF_CONFIG1_OVRD	87
17.43	IOC_PAD_SCENARIO	88
17.44	IOC_PAD_SCENARIO_AUX_OVRD	88
17.45	DRIVE_CONFIG0	89
17.46	DRIVE_CONFIG1	90
17.47	DRIVE_CONFIG2	90
17.48	REG_MISC1	91
17.49	INT_APEX_CONFIG0	92
17.50	INT_APEX_CONFIG1	93
17.51	INT_APEX_STATUS0	93
17.52	INT_APEX_STATUS1	94
17.53	INT2_CONFIG0	95
17.54	INT2_CONFIG1	97
17.55	INT2_CONFIG2	98
17.56	INT2_STATUS0	99
17.57	INT2_STATUS1	100
17.58	WHO_AM_I	100
17.59	REG_HOST_MSG	101
17.60	IREG_ADDR_15_8	101
17.61	IREG_ADDR_7_0	101
17.62	IREG_DATA	101
17.63	REG_MISC2	102
18	User Bank IMEM_SRAM Register Map – Descriptions	103
18.1	IMEM_SRAM_REG_0	103
18.2	IMEM_SRAM_REG_1	103
18.3	IMEM_SRAM_REG_2	103
18.4	IMEM_SRAM_REG_3	103
18.5	IMEM_SRAM_REG_4	104
18.6	IMEM_SRAM_REG_5	104
18.7	IMEM_SRAM_REG_6	104
18.8	IMEM_SRAM_REG_7	104
18.9	IMEM_SRAM_REG_8	105

18.10	IMEM_SRAM_REG_9.....	105
18.11	IMEM_SRAM_REG_10.....	105
18.12	IMEM_SRAM_REG_11.....	105
18.13	IMEM_SRAM_REG_56.....	106
18.14	IMEM_SRAM_REG_57.....	106
18.15	IMEM_SRAM_REG_64.....	107
18.16	IMEM_SRAM_REG_68.....	107
18.17	IMEM_SRAM_REG_92.....	108
18.18	IMEM_SRAM_REG_96.....	108
18.19	IMEM_SRAM_REG_97.....	108
18.20	IMEM_SRAM_REG_98.....	108
18.21	IMEM_SRAM_REG_99.....	109
18.22	IMEM_SRAM_REG_100.....	109
18.23	IMEM_SRAM_REG_101.....	109
18.24	IMEM_SRAM_REG_102.....	109
18.25	IMEM_SRAM_REG_103.....	109
18.26	IMEM_SRAM_REG_104.....	110
18.27	IMEM_SRAM_REG_105.....	110
18.28	IMEM_SRAM_REG_106.....	110
18.29	IMEM_SRAM_REG_107.....	110
18.30	IMEM_SRAM_REG_136.....	111
18.31	IMEM_SRAM_REG_137.....	111
18.32	IMEM_SRAM_REG_138.....	111
18.33	IMEM_SRAM_REG_139.....	111
18.34	IMEM_SRAM_REG_141.....	112
18.35	IMEM_SRAM_REG_142.....	112
18.36	IMEM_SRAM_REG_143.....	112
18.37	IMEM_SRAM_REG_144.....	112
18.38	IMEM_SRAM_REG_146.....	113
18.39	IMEM_SRAM_REG_154.....	113
18.40	IMEM_SRAM_REG_155.....	113
18.41	IMEM_SRAM_REG_156.....	113
18.42	IMEM_SRAM_REG_157.....	114
18.43	IMEM_SRAM_REG_159.....	114
18.44	IMEM_SRAM_REG_160.....	114
18.45	IMEM_SRAM_REG_182.....	114
18.46	IMEM_SRAM_REG_185.....	115

18.47	IMEM_SRAM_REG_186.....	115
18.48	IMEM_SRAM_REG_196.....	115
18.49	IMEM_SRAM_REG_197.....	115
18.50	IMEM_SRAM_REG_198.....	116
18.51	IMEM_SRAM_REG_199.....	116
18.52	IMEM_SRAM_REG_288.....	116
18.53	IMEM_SRAM_REG_289.....	117
18.54	IMEM_SRAM_REG_290.....	117
18.55	IMEM_SRAM_REG_291.....	117
18.56	IMEM_SRAM_REG_292.....	117
18.57	IMEM_SRAM_REG_293.....	118
18.58	IMEM_SRAM_REG_294.....	118
18.59	IMEM_SRAM_REG_295.....	118
18.60	IMEM_SRAM_REG_296.....	118
18.61	IMEM_SRAM_REG_297.....	119
18.62	IMEM_SRAM_REG_298.....	119
18.63	IMEM_SRAM_REG_299.....	119
18.64	IMEM_SRAM_REG_304.....	120
18.65	IMEM_SRAM_REG_305.....	120
18.66	IMEM_SRAM_REG_306.....	120
18.67	IMEM_SRAM_REG_307.....	120
18.68	IMEM_SRAM_REG_308.....	121
18.69	IMEM_SRAM_REG_309.....	121
18.70	IMEM_SRAM_REG_316.....	121
18.71	IMEM_SRAM_REG_317.....	121
18.72	IMEM_SRAM_REG_318.....	122
18.73	IMEM_SRAM_REG_319.....	122
18.74	IMEM_SRAM_REG_320.....	122
18.75	IMEM_SRAM_REG_321.....	122
18.76	IMEM_SRAM_REG_392.....	123
18.77	IMEM_SRAM_REG_393.....	123
18.78	IMEM_SRAM_REG_400.....	123
18.79	IMEM_SRAM_REG_401.....	124
18.80	IMEM_SRAM_REG_402.....	124
18.81	IMEM_SRAM_REG_403.....	124
18.82	IMEM_SRAM_REG_404.....	125
18.83	IMEM_SRAM_REG_405.....	125

18.84	IMEM_SRAM_REG_406.....	125
18.85	IMEM_SRAM_REG_540.....	126
18.86	IMEM_SRAM_REG_541.....	126
18.87	IMEM_SRAM_REG_542.....	126
18.88	IMEM_SRAM_REG_543.....	127
18.89	IMEM_SRAM_REG_544.....	127
18.90	IMEM_SRAM_REG_545.....	127
18.91	IMEM_SRAM_REG_546.....	128
18.92	IMEM_SRAM_REG_547.....	128
18.93	IMEM_SRAM_REG_548.....	128
18.94	IMEM_SRAM_REG_549.....	129
18.95	IMEM_SRAM_REG_550.....	129
18.96	IMEM_SRAM_REG_551.....	129
18.97	IMEM_SRAM_REG_556.....	130
18.98	IMEM_SRAM_REG_557.....	130
18.99	IMEM_SRAM_REG_558.....	130
18.100	IMEM_SRAM_REG_559.....	131
18.101	IMEM_SRAM_REG_560.....	131
18.102	IMEM_SRAM_REG_561.....	131
18.103	IMEM_SRAM_REG_562.....	132
18.104	IMEM_SRAM_REG_563.....	132
18.105	IMEM_SRAM_REG_564.....	132
18.106	IMEM_SRAM_REG_565.....	133
18.107	IMEM_SRAM_REG_566.....	133
18.108	IMEM_SRAM_REG_567.....	133
18.109	IMEM_SRAM_REG_568.....	134
18.110	IMEM_SRAM_REG_569.....	134
18.111	IMEM_SRAM_REG_570.....	134
18.112	IMEM_SRAM_REG_571.....	135
18.113	IMEM_SRAM_REG_572.....	135
18.114	IMEM_SRAM_REG_573.....	135
18.115	IMEM_SRAM_REG_574.....	136
18.116	IMEM_SRAM_REG_575.....	136
18.117	IMEM_SRAM_REG_576.....	136
18.118	IMEM_SRAM_REG_577.....	137
18.119	IMEM_SRAM_REG_578.....	137
18.120	IMEM_SRAM_REG_579.....	137

18.121	IMEM_SRAM_REG_580	138
18.122	IMEM_SRAM_REG_581	138
18.123	IMEM_SRAM_REG_582	138
18.124	IMEM_SRAM_REG_583	139
18.125	IMEM_SRAM_REG_584	139
18.126	IMEM_SRAM_REG_585	139
18.127	IMEM_SRAM_REG_586	140
18.128	IMEM_SRAM_REG_587	140
18.129	IMEM_SRAM_REG_988	140
18.130	IMEM_SRAM_REG_989	141
18.131	IMEM_SRAM_REG_990	141
18.132	IMEM_SRAM_REG_991	141
18.133	IMEM_SRAM_REG_994	142
18.134	IMEM_SRAM_REG_995	142
18.135	IMEM_SRAM_REG_1000	142
18.136	IMEM_SRAM_REG_1001	143
18.137	IMEM_SRAM_REG_1002	143
18.138	IMEM_SRAM_REG_1003	143
18.139	IMEM_SRAM_REG_1004	144
18.140	IMEM_SRAM_REG_1008	144
18.141	IMEM_SRAM_REG_1009	144
18.142	IMEM_SRAM_REG_1010	145
18.143	IMEM_SRAM_REG_1011	145
18.144	IMEM_SRAM_REG_1016	145
18.145	IMEM_SRAM_REG_1017	146
18.146	IMEM_SRAM_REG_1018	146
18.147	IMEM_SRAM_REG_1019	146
18.148	IMEM_SRAM_REG_1042	147
18.149	IMEM_SRAM_REG_1168 to IMEM_SRAM_REG_1203	147
19	User Bank IPREG_BAR Register Map – Descriptions	148
19.1	IPREG_BAR_REG_57	148
19.2	IPREG_BAR_REG_58	149
19.3	IPREG_BAR_REG_59	150
19.4	IPREG_BAR_REG_60	151
19.5	IPREG_BAR_REG_61	152
19.6	IPREG_BAR_REG_62	153
20	User Bank IPREG_TOP1 Register Map – Descriptions	154

20.1	I2CM_COMMAND_0	154
20.2	I2CM_COMMAND_1	155
20.3	I2CM_COMMAND_2	156
20.4	I2CM_COMMAND_3	157
20.5	I2CM_DEV_PROFILE0	158
20.6	I2CM_DEV_PROFILE1	158
20.7	I2CM_DEV_PROFILE2	158
20.8	I2CM_DEV_PROFILE3	158
20.9	I2CM_CONTROL.....	159
20.10	I2CM_STATUS.....	159
20.11	I2CM_EXT_DEV_STATUS	160
20.12	I2CM_RD_DATA0.....	160
20.13	I2CM_RD_DATA1.....	161
20.14	I2CM_RD_DATA2.....	161
20.15	I2CM_RD_DATA3.....	161
20.16	I2CM_RD_DATA4.....	162
20.17	I2CM_RD_DATA5.....	162
20.18	I2CM_RD_DATA6.....	162
20.19	I2CM_RD_DATA7.....	163
20.20	I2CM_RD_DATA8.....	163
20.21	I2CM_RD_DATA9.....	163
20.22	I2CM_RD_DATA10.....	164
20.23	I2CM_RD_DATA11.....	164
20.24	I2CM_RD_DATA12.....	164
20.25	I2CM_RD_DATA13.....	165
20.26	I2CM_RD_DATA14.....	165
20.27	I2CM_RD_DATA15.....	165
20.28	I2CM_RD_DATA16.....	166
20.29	I2CM_RD_DATA17.....	166
20.30	I2CM_RD_DATA18.....	166
20.31	I2CM_RD_DATA19.....	167
20.32	I2CM_RD_STATUS20	167
20.33	I2CM_WR_DATA0.....	167
20.34	I2CM_WR_DATA1.....	167
20.35	I2CM_WR_DATA2.....	168
20.36	I2CM_WR_DATA3.....	168
20.37	I2CM_WR_DATA4.....	168

20.38	I2CM_WR_DATA5.....	168
20.39	SIFS_IXC_ERROR_STATUS.....	169
20.40	EDMP_PRGRM_IRQ0_0.....	169
20.41	EDMP_PRGRM_IRQ0_1.....	169
20.42	EDMP_PRGRM_IRQ1_0.....	170
20.43	EDMP_PRGRM_IRQ1_1.....	170
20.44	EDMP_PRGRM_IRQ2_0.....	170
20.45	EDMP_PRGRM_IRQ2_1.....	170
20.46	EDMP_SP_START_ADDR.....	171
20.47	SMC_CONTROL_0.....	171
20.48	SMC_CONTROL_1.....	172
20.49	STC_CONFIG.....	172
20.50	SREG_CTRL.....	173
20.51	SIFS_I3C_STC_CFG.....	173
20.52	INT_PULSE_MIN_ON_INTF0.....	174
20.53	INT_PULSE_MIN_ON_INTF1.....	174
20.54	INT_PULSE_MIN_OFF_INTF0.....	174
20.55	INT_PULSE_MIN_OFF_INTF1.....	175
20.56	ISR_0_7.....	175
20.57	ISR_8_15.....	176
20.58	ISR_16_23.....	176
20.59	STATUS_MASK_PIN_0_7.....	177
20.60	STATUS_MASK_PIN_8_15.....	178
20.61	STATUS_MASK_PIN_16_23.....	179
20.62	INT_I2CM_SOURCE.....	179
20.63	ACCEL_WOM_X_THR.....	179
20.64	ACCEL_WOM_Y_THR.....	180
20.65	ACCEL_WOM_Z_THR.....	180
20.66	SELFTEST.....	181
20.67	IPREG_MISC.....	181
20.68	SW_PLL1_TRIM.....	182
20.69	FIFO_SRAM_SLEEP.....	182
21	User Bank IPREG_SYS1 Register Map – Descriptions.....	183
21.1	IPREG_SYS1_REG_42.....	183
21.2	IPREG_SYS1_REG_43.....	183
21.3	IPREG_SYS1_REG_56.....	183
21.4	IPREG_SYS1_REG_57.....	183

21.5	IPREG_SYS1_REG_70	184
21.6	IPREG_SYS1_REG_71	184
21.7	IPREG_SYS1_REG_166	184
21.8	IPREG_SYS1_REG_170	185
21.9	IPREG_SYS1_REG_172	185
22	User Bank IPREG_SYS2 Register Map – Descriptions	186
22.1	IPREG_SYS2_REG_24	186
22.2	IPREG_SYS2_REG_25	186
22.3	IPREG_SYS2_REG_32	186
22.4	IPREG_SYS2_REG_33	186
22.5	IPREG_SYS2_REG_40	187
22.6	IPREG_SYS2_REG_41	187
22.7	IPREG_SYS2_REG_123	187
22.8	IPREG_SYS2_REG_129	188
22.9	IPREG_SYS2_REG_131	188
23	Reference	189
24	Revision History	190

TABLE OF FIGURES

Figure 1. I²C Bus Timing Diagram 22

Figure 2. 4-Wire SPI Bus Timing Diagram 23

Figure 3. 3-Wire SPI Bus Timing Diagram 24

Figure 4. Pin Out Diagram for ICM-45605 2.5x3.0x0.81 mm LGA 29

Figure 5. ICM-45605 Application Schematic Dual Interface I²C Master Mode (I3CSM / I²C Interface to Host) 29

Figure 6. ICM-45605 Application Schematic Dual Interface I²C Master Mode (SPI Interface to Host)..... 30

Figure 7. ICM-45605 Application Schematic Single Interface Mode (I3CSM / I²C Interface to Host)..... 30

Figure 8. ICM-45605 Application Schematic Single Interface Mode (SPI Interface to Host) 31

Figure 9. ICM-45605 System Block Diagram 32

Figure 10. ICM-45605 Signal Path..... 36

Figure 11. Typical SPI Master/Slave Configuration 47

Figure 12. Orientation of Axes of Sensitivity and Polarity of Rotation 48

Figure 13. ICM-45605 Device Package in Tape and Reel 51

Figure 14. Tape Dimensions with ICM-45605 Device Package 51

TABLE OF TABLES

Table 1. Gyroscope Specifications 17

Table 2. Accelerometer Specifications 18

Table 3. D.C. Electrical Characteristics 19

Table 4. A.C. Electrical Characteristics 20

Table 5. I²C Host Interface Timing Characteristics 21

Table 6. I²C Master Interface Timing Characteristics 21

Table 7. 4-Wire SPI Timing Characteristics 23

Table 8. 3-Wire SPI Timing Characteristics 24

Table 9. Absolute Maximum Ratings 25

Table 10. Signal Descriptions 28

Table 11. Bill of Materials 31

Table 12. Standard Power Modes for ICM-45605 35

Table 13. I3CSM CCC Commands..... 46

1 INTRODUCTION

1.1 PURPOSE AND SCOPE

This document is a product specification, providing a description, specifications, and design related information on the ICM-45605 Dual-Interface MotionTracking device. The device is housed in a small 2.5x3x0.81 mm 14-pin LGA package.

1.2 PRODUCT OVERVIEW

The ICM-45605 is a 6-axis MotionTracking device with a configurable host interface that supports I3CSM, I²C and SPI serial communication, and an I²C master mode interface for connection to external sensors. It combines a 3-axis gyroscope, and a 3-axis accelerometer in a small 2.5x3x0.81 mm (14-pin LGA) package.

ICM-45605 also features up to 8Kbytes FIFO that can lower the traffic on the serial bus interface, and reduce power consumption by allowing the system processor to burst read sensor data and then go into a low-power mode. ICM-45605, with its 6-axis integration, enables manufacturers to eliminate the costly and complex selection, qualification, and system level integration of discrete devices, guaranteeing optimal motion performance for consumers.

The gyroscope supports independently programmable full-scale range settings from ± 15.625 dps to ± 2000 dps for the UI path, and the accelerometer supports independently programmable full-scale range settings from ± 2 g to ± 16 g for the UI path.

Other industry-leading features include on-chip 16-bit ADCs, programmable digital filters, an embedded temperature sensor, and programmable interrupts. The device features I3CSM, I²C and SPI serial interfaces, a VDD operating range of 1.71V to 3.6V, and a separate VDDIO operating range of 1.08V to 3.6V.

The host interface can be configured to support I3CSM slave, I²C slave, or SPI slave modes. The I3CSM interface supports speeds up to 12.9MHz (data rates up to 12.9Mbps in SDR mode, 25.8Mbps in DDR mode), the I²C interface supports speeds up to 1MHz, and the SPI interface supports speeds up to 24MHz.

User configurable internal pull-up/pull-downs are included on I/O interfaces to reduce system costs associated with external pull-ups/pull-downs.

By leveraging its patented and volume-proven CMOS-MEMS fabrication platform, which integrates MEMS wafers with companion CMOS electronics through wafer-level bonding, TDK InvenSense has driven the package size down to a footprint and thickness of 2.5x3x0.81 mm (14-pin LGA), to provide a very small yet high performance low cost package. The device provides high robustness by supporting 20,000g shock reliability.

1.3 APPLICATIONS

- Game Controllers
- Cameras
- IoT
- Drones
- Non-OIS SmartPhones
- Wearables
- Hearables

2 FEATURES

2.1 GYROSCOPE FEATURES

The triple-axis MEMS gyroscope in the ICM-45605 includes a wide range of features:

- Digital-output X-, Y-, and Z-axis angular rate sensors (gyroscopes) with independently programmable full-scale range of ± 15.625 , ± 31.25 , ± 62.5 , ± 125 , ± 250 , ± 500 , ± 1000 , and ± 2000 degrees/sec for UI and auxiliary paths
- Low Noise (LN) and Low Power (LP) power modes support
- Digitally-programmable low-pass filters
- Self-test

2.2 ACCELEROMETER FEATURES

The triple-axis MEMS accelerometer in ICM-45605 includes a wide range of features:

- Digital-output X-, Y-, and Z-axis accelerometer with independently programmable full-scale range of $\pm 2g$, $\pm 4g$, $\pm 8g$ and $\pm 16g$ for UI and auxiliary paths
- Low Noise (LN) and Low Power (LP) power modes support
- User-programmable interrupts
- Wake-on-motion interrupt for low power operation of applications processor
- Self-test

2.3 MOTION FEATURES

ICM-45605 includes the following motion features, also known as APEX (**A**dvanced **P**edometer and **E**vent Detection – neXt gen)

- Pedometer: Tracks Step Count, also issues Step Detect interrupt.
- Tilt Detection: Issues an interrupt when the Tilt angle exceeds 35° for more than a programmable time.
- Raise to Wake/Sleep: Gesture detection for wake and sleep events. Interrupt is issued when either of these two events are detected.
- Single Tap / Double Tap Detection: Issues an interrupt when a tap is detected, along with the tap type.
- Wake on Motion: Detects motion when accelerometer data exceeds a programmable threshold.
- Freefall Detection: Triggers an interrupt when device freefall is detected and outputs freefall duration.
- Significant Motion Detection: Detects significant motion based on accelerometer data.
- Low-G Detection: Triggers an interrupt when absolute value of accelerometer combined axis falls below a programmable threshold and stays below the threshold for a programmable time.
- High-G Detection: Triggers an interrupt when absolute value of accelerometer goes above a programmable threshold and stays above the threshold for a programmable time.

2.4 ADDITIONAL FEATURES

ICM-45605 includes the following additional features:

- Up to 8Kbytes FIFO buffer enables the applications processor to read the data in bursts, default FIFO size is 2Kbytes, user can extend it up to 8kByte by disabling APEX functions
- EDMP Enhanced Digital Motion Processor for implementing motion algorithms
- 20-bits data format support in FIFO for high-data resolution
- User-programmable digital filters for gyroscope, accelerometer, and temperature sensor
- Main interface: 12.5MHz I3CSM (data rates up to 12.5Mbps in SDR mode, 25Mbps in DDR mode) / 1 MHz I²C / 24 MHz SPI slave host interface
- Auxiliary interface: 400 kHz I²C master
- User configurable internal pull-up/pull-downs included on I/O interfaces to reduce system costs associated with external pull-ups/pull-downs
- User configurable Output Data Rate (ODR) and FIFO Data Rate (FDR)
- Digital-output temperature sensor
- Smallest and thinnest LGA package for portable devices: 2.5x3x0.81 mm (14-pin LGA)
- 20,000 *g* shock tolerant
- MEMS structure hermetically sealed and bonded at wafer level
- RoHS and Green compliant

3 ELECTRICAL CHARACTERISTICS

3.1 GYROSCOPE SPECIFICATIONS

Typical Operating Circuit of section 4.2, VDD = 1.8 V, VDDIO = 1.8V, T_A=25°C, unless otherwise noted.

PARAMETER	CONDITIONS	MIN	TYP	MAX	UNITS	NOTES
GYROSCOPE SENSITIVITY						
Full-Scale Range	GYRO_UI_FS_SEL =1		±2000		°/s	3
	GYRO_UI_FS_SEL =2		±1000		°/s	3
	GYRO_UI_FS_SEL =3		±500		°/s	3
	GYRO_UI_FS_SEL =4		±250		°/s	3
	GYRO_UI_FS_SEL =5		±125		°/s	3
	GYRO_UI_FS_SEL =6		±62.5		°/s	3
	GYRO_UI_FS_SEL =7		±31.25		°/s	3
	GYRO_UI_FS_SEL =8		±15.625		°/s	3
Gyroscope ADC Word Length	Output in two's complement format		16		bits	3, 6
Sensitivity Scale Factor	GYRO_UI_FS_SEL =1		16.4		LSB/(°/s)	3
	GYRO_UI_FS_SEL =2		32.8		LSB/(°/s)	3
	GYRO_UI_FS_SEL =3		65.5		LSB/(°/s)	3
	GYRO_UI_FS_SEL =4		131		LSB/(°/s)	3
	GYRO_UI_FS_SEL =5		262		LSB/(°/s)	3
	GYRO_UI_FS_SEL =6		524.3		LSB/(°/s)	3
	GYRO_UI_FS_SEL =7		1048.6		LSB/(°/s)	3
	GYRO_UI_FS_SEL =8		2097.2		LSB/(°/s)	3
Sensitivity Scale Factor Initial Tolerance	Component-level, 25°C		±0.5		%	2
Sensitivity Change vs. Temperature	-40°C to +85°C, board-level		±0.01		%/°C	1, 8
Nonlinearity	Best fit straight line; board-level, 25°C		±0.1		%	1, 8
Cross-Axis Sensitivity	Board-level		±1		%	1, 8
ZERO-RATE OUTPUT (ZRO)						
Initial ZRO Tolerance	Component-level, 25°C		±0.5		°/s	2
ZRO Change vs. Temperature	-40°C to +85°C, board-level		±0.015		°/s/°C	1, 8
OTHER PARAMETERS						
Rate Noise Spectral Density	@ 10 Hz, 25°C		0.0038		°/s /√Hz	2, 4
Total RMS Noise	Bandwidth = 100 Hz		0.038		°/s-rms	4, 5
Gyroscope Mechanical Frequencies			29.7		kHz	2
Gyroscope Start-Up Time	Time from gyro enable to gyro drive ready		35	45	ms	1, 7
Output Data Rate	Low Noise Mode (LNM)	12.5		6400	Hz	3
	Low Power Mode (LPM)	1.5625		400	Hz	3

Table 1. Gyroscope Specifications

Notes:

1. Derived from validation or characterization of parts, not tested in production.
2. Tested in production.
3. Guaranteed by design.
4. Noise specifications shown are for low-noise mode.
5. Calculated from Rate Noise Spectral Density.
6. 20-bits data format supported in FIFO, see section 6.
7. Measurement conditions: Gyroscope ODR = 6400Hz; Register field GYRO_UI_LPFBW_SEL set to 000 (low pass filter bypassed).
8. Board-level specs performance depends on specific board design of TDK-InvenSense test boards and may not be directly reproducible with other board designs.

3.2 ACCELEROMETER SPECIFICATIONS

Typical Operating Circuit of section 4.2, VDD = 1.8 V, VDDIO = 1.8V, T_A=25°C, unless otherwise noted.

PARAMETER	CONDITIONS	MIN	TYP	MAX	UNITS	NOTES
ACCELEROMETER SENSITIVITY						
Full-Scale Range	ACCEL_UI_FS_SEL = 1		±16		g	3
	ACCEL_UI_FS_SEL = 2		±8		g	3
	ACCEL_UI_FS_SEL = 3		±4		g	3
	ACCEL_UI_FS_SEL = 4		±2		g	3
ADC Word Length	Output in two's complement format		16		bits	3, 6
Sensitivity Scale Factor	ACCEL_UI_FS_SEL = 1		2,048		LSB/g	3
	ACCEL_UI_FS_SEL = 2		4,096		LSB/g	3
	ACCEL_UI_FS_SEL = 3		8,192		LSB/g	3
	ACCEL_UI_FS_SEL = 4		16,384		LSB/g	3
Sensitivity Scale Factor Initial Tolerance	Component-level, 25°C		±0.5		%	2
Sensitivity Change vs. Temperature	-40°C to +85°C, board-level		±0.01		%/°C	1, 8
Nonlinearity	Best fit straight line, ±2g; board-level, 25°C		±0.1		%	1, 8
Cross-Axis Sensitivity	Board-level		±1		%	1, 8
ZERO-G OUTPUT						
Initial Tolerance	Component-level, 25°C		±15		mg	2
Zero-G Level Change vs. Temperature	-40°C to +85°C, board-level		±0.15		mg/°C	1, 8
OTHER PARAMETERS						
Noise Spectral Density	@ 10 Hz; Up to ±8g FSR		70		µg/√Hz	2, 4
	@ 10 Hz; ±16g FSR		80		µg/√Hz	2, 4
RMS Noise	Bandwidth = 100 Hz; Up to ±8g FSR		0.7		mg-rms	4, 5
	Bandwidth = 100 Hz; ±16g FSR		0.8		mg-rms	4, 5
Accelerometer Startup Time	From sleep mode to valid data		10		ms	1, 7
Output Data Rate	Low Noise Mode (LNM)	12.5		6400	12.5	3
	Low Power Mode (LPM)	1.5625		400	1.5625	3

Table 2. Accelerometer Specifications

Notes:

1. Derived from validation or characterization of parts, not tested in production.
2. Tested in production.
3. Guaranteed by design.
4. Noise specifications shown are for low-noise mode.
5. Calculated from Rate Noise Spectral Density.
6. 20-bits data format supported in FIFO, see section 6.
7. Measurement conditions: Gyroscope ODR = 6400Hz; Register field GYRO_UI_LPFBW_SEL set to 000 (low pass filter bypassed).
8. Board-level specs performance depends on specific board design of TDK-InvenSense test boards and may not be directly reproducible with other board designs.

3.3 ELECTRICAL SPECIFICATIONS

3.3.1 D.C. Electrical Characteristics

Typical Operating Circuit of section 4.2, VDD = 1.8 V, VDDIO = 1.8V, T_A=25°C, unless otherwise noted.

PARAMETER	CONDITIONS	MIN	TYP	MAX	UNITS	NOTES
SUPPLY VOLTAGES						
VDD		1.71	1.8	3.6	V	1
VDDIO		1.08*	1.8	3.6	V	1
SUPPLY CURRENTS						
Low-Noise Mode	6-Axis Gyroscope + Accelerometer (1600Hz ODR)		420		μA	2
	6-Axis Gyroscope + Accelerometer (6400Hz ODR)		440		μA	2
	3-Axis Accelerometer (1600Hz ODR)		120		μA	2
	3-Axis Accelerometer (6400Hz ODR)		130		μA	2
	3-Axis Gyroscope (1600Hz ODR)		360		μA	2
	3-Axis Gyroscope (6400Hz ODR)		370		μA	2
Low-Power Mode	6-Axis Gyroscope + Accelerometer (50Hz ODR; Gyro 10x AVG; Accel 4x AVG)		220		μA	2
	6-Axis Gyroscope + Accelerometer (200Hz ODR; Gyro 10x AVG; Accel 4x AVG)		325		μA	2
	3-Axis Accelerometer (50Hz ODR; 4x AVG)		67		μA	2
	3-Axis Gyroscope (50Hz ODR; 10x AVG)		210		μA	2
Ultra Low-Power Mode	3-Axis Accelerometer (50Hz ODR; 1x AVG)		15		μA	2
Full-Chip Sleep Mode	At 25°C		2.2		μA	2
TEMPERATURE RANGE						
Specified Temperature Range	Performance parameters are not applicable beyond Specified Temperature Range	-40		+85	°C	1

Table 3. D.C. Electrical Characteristics

Notes:

1. Guaranteed by design.
2. Derived from validation or characterization of parts, not tested in production.

* Important Note: When using I3CSM interface the minimum VDDIO value is 1.1V.

3.3.2 A.C. Electrical Characteristics

Typical Operating Circuit of section 4.2, VDD = 1.8 V, VDDIO = 1.8V, T_A=25°C, unless otherwise noted.

PARAMETER	CONDITIONS	MIN	TYP	MAX	UNITS	NOTES
SUPPLIES						
Supply Ramp Time	Valid power-on RESET Monotonic ramp. Ramp rate is 10% to 90% of the final value	0.01		1	ms	1
Power Supply Noise	V _{DD} =1.8V or 3.6V, up to 1MHz		10	50	mV peak-peak	1
TEMPERATURE SENSOR						
Operating Range	Ambient	-40		85	°C	1
25°C Output	Output in two's complement format		0		LSB	3
ADC Resolution			16		bits	2
ODR	With Filter	1.5625		3200	Hz	2, 4
Room Temperature Offset	25°C	-5		5	°C	3
Stabilization Time (fixed number of clock cycles)				0.014	sec	2
Sensitivity	Trimmed		128		LSB/°C	1
Sensitivity for FIFO data	Trimmed		2		LSB/°C	1
POWER-ON RESET						
Start-up time for register read/write	From power-up			1	ms	1
I²C ADDRESS						
I ² C ADDRESS	AP_AD0 = 0 AP_AD0 = 1		1101000 1101001			
DIGITAL INPUTS (FSYNC, SCLK, SDI, CS)						
V _{IH} , High Level Input Voltage		0.7*VDDIO		VDDIO + 0.5V	V	1
V _{IL} , Low Level Input Voltage		-0.5V		0.3*VDDIO	V	
C _i , Input Capacitance			<10		pF	
DIGITAL OUTPUT (SDO, INT1, INT2)						
V _{OH} , High Level Output Voltage	R _{LOAD} =1 MΩ;	0.9*VDDIO			V	1
V _{OL} , LOW-Level Output Voltage	R _{LOAD} =1 MΩ;			0.1*VDDIO	V	
V _{OLINT} , INT Low-Level Output Voltage	OPEN=1, 0.3 mA sink Current			0.1	V	
Output Leakage Current	OPEN=1		100		nA	
t _{INT} , INT Pulse Width	int0_tpulse_duration= 0, 1 (100μs, 8μs) int1_tpulse_duration= 0, 1 (100μs, 8μs)		100 or 8	100	μs	
I²C I/O (SCL, SDA)						
V _{IL} , LOW-Level Input Voltage		-0.5V		0.3*VDDIO	V	1
V _{IH} , HIGH-Level Input Voltage		0.7*VDDIO		VDDIO + 0.5V	V	
V _{hys} , Hysteresis			0.1*VDDIO		V	
V _{OL} , LOW-Level Output Voltage	3 mA sink current	0		0.4	V	
I _{OL} , LOW-Level Output Current	V _{OL} =0.4 V V _{OL} =0.6 V		3 6		mA mA	
Output Leakage Current			100		nA	
t _{of} , Output Fall Time from V _{IHmax} to V _{ILmax}	C _b bus capacitance in pf	20+0.1C _b		300	ns	
INTERNAL CLOCK SOURCE						
Clock Frequency Initial Tolerance	Gyro inactive; 25°C	-1.25		+1.25	%	1
	Gyro active; 25°C	-1.25		+1.25	%	1
Frequency Variation over Temperature	Gyro inactive; -40°C to +85°C			±3	%	1
	Gyro active; -40°C to +85°C			±1	%	1

Table 4. A.C. Electrical Characteristics

Notes:

1. Based on design. Not tested in production.
2. Guaranteed by design.
3. Production tested.
4. Temperature sensor ODR is the higher value between gyroscope and accelerometer ODR.

3.4 I²C TIMING CHARACTERIZATION

Typical Operating Circuit of section 4.2, VDD = 1.8 V, VDDIO = 1.8V, T_A=25°C, unless otherwise noted.

Parameters	Conditions	Min	Typical	Max	Units	Notes
I²C TIMING (Host Interface)		I²C FAST-MODE PLUS				
f _{SCL} , SCL Clock Frequency				1	MHz	1
t _{HD,STA} , (Repeated) START Condition Hold Time		0.26			μs	1
t _{LOW} , SCL Low Period		0.50			μs	1
t _{HIGH} , SCL High Period		0.26			μs	1
t _{SU,STA} , Repeated START Condition Setup Time		0.26			μs	1
t _{HD,DAT} , SDA Data Hold Time		0			μs	1
t _{SU,DAT} , SDA Data Setup Time		50			ns	1
t _r , SDA and SCL Rise Time	C _b bus cap. from 30 to 130 pF			120	ns	1, 2
t _f , SDA and SCL Fall Time	C _b bus cap. from 30 to 130 pF		20 x (VDD / 5.5 V)	120	ns	1, 2
t _{SU,STO} , STOP Condition Setup Time		0.26			μs	1
t _{BUF} , Bus Free Time Between STOP and START Condition		0.50			μs	1
C _b , Capacitive Load for each Bus Line		30		130	pF	1
t _{VD,DAT} , Data Valid Time				0.45	μs	1
t _{VD,ACK} , Data Valid Acknowledge Time				0.45	μs	1

Table 5. I²C Host Interface Timing Characteristics

Notes:

1. Based on characterization of 5 parts over temperature and voltage as mounted on evaluation board or in sockets.
2. Transition times are defined between thresholds: 0.3*VDDIO, 0.7*VDDIO.

Typical Operating Circuit of section 4.2, VDD = 1.8 V, VDDIO = 1.8V, T_A=25°C, unless otherwise noted.

Parameters	Conditions	Min	Typical	Max	Units	Notes
I²C TIMING (Master Interface)		I²C FAST-MODE				
f _{SCL} , SCL Clock Frequency				400	kHz	1
t _{HD,STA} , (Repeated) START Condition Hold Time		0.60			μs	1
t _{LOW} , SCL Low Period		1.30			μs	1
t _{HIGH} , SCL High Period		0.60			μs	1
t _{SU,STA} , Repeated START Condition Setup Time		0.60			μs	1
t _{HD,DAT} , SDA Data Hold Time		0			μs	1
t _{SU,DAT} , SDA Data Setup Time		100			ns	1
t _r , SDA and SCL Rise Time	C _b bus cap. from 30 to 200 pF	20		300	ns	1, 2
t _f , SDA and SCL Fall Time	C _b bus cap. from 30 to 200 pF		20 x (VDD / 5.5 V)	300	ns	1, 2
t _{SU,STO} , STOP Condition Setup Time				0.60	μs	1
t _{BUF} , Bus Free Time Between STOP and START Condition		1.30			μs	1
C _b , Capacitive Load for each Bus Line		30		200	pF	1
t _{VD,DAT} , Data Valid Time				0.90	μs	1
t _{VD,ACK} , Data Valid Acknowledge Time				0.90	μs	1

Table 6. I²C Master Interface Timing Characteristics

Notes:

1. Based on characterization of 5 parts over temperature and voltage as mounted on evaluation board or in sockets.
2. Transition times are defined between thresholds: 0.3*VDDIO, 0.7*VDDIO.

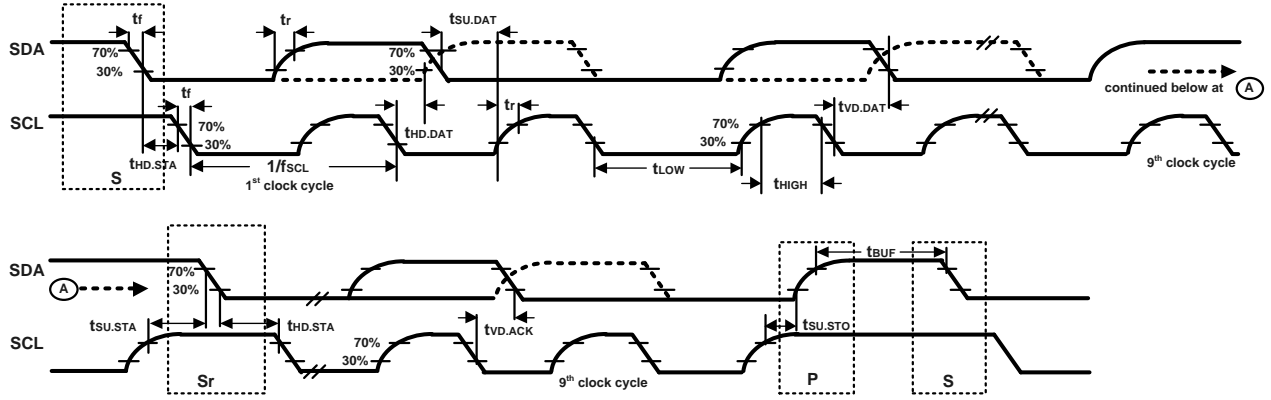

Figure 1. I²C Bus Timing Diagram

3.5 SPI TIMING CHARACTERIZATION – 4-WIRE SPI MODE

Typical Operating Circuit of section 4.2, VDD = 1.8 V, VDDIO = 1.8V, T_A=25°C, unless otherwise noted.

PARAMETERS	CONDITIONS	VDDIO < 1.71V		VDDIO ≥ 1.71V		UNITS	NOTES
		MIN	MAX	MIN	MAX		
SPI TIMING							
f _{SPC} , SCLK Clock Frequency	Default		20		24	MHz	1
t _{LOW} , SCLK Low Period		23.5		17		ns	1
t _{HIGH} , SCLK High Period		22.5		17		ns	1
t _{SU,CS} , CS Setup Time		17		17		ns	1
t _{HD,CS} , CS Hold Time		5		5		ns	1
t _{SU,SDI} , SDI Setup Time		13		13		ns	1
t _{HD,SDI} , SDI Hold Time		8		8		ns	1
t _{VD,SDO} , SDO Valid Time	C _{load} = 20 pF		18.5		18.5	ns	1
t _{HD,SDO} , SDO Hold Time	C _{load} = 20 pF	3.5		3.5		ns	1
t _{DIS,SDO} , SDO Output Disable Time			28		28	ns	1

Table 7. 4-Wire SPI Timing Characteristics

Notes:

1. Based on characterization of 5 parts over temperature and voltage as mounted on evaluation board or in sockets

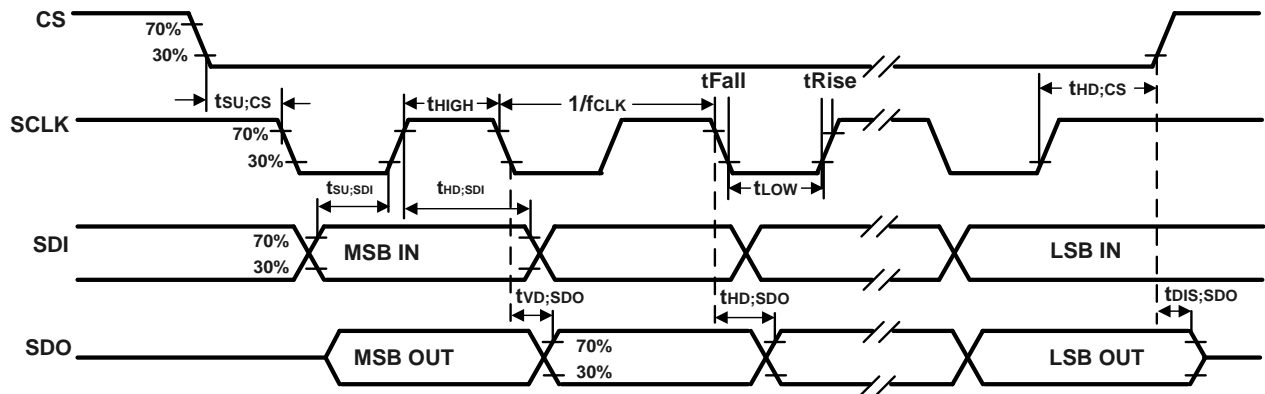

Figure 2. 4-Wire SPI Bus Timing Diagram

3.6 SPI TIMING CHARACTERIZATION – 3-WIRE SPI MODE

Typical Operating Circuit of section 4.2, VDD = 1.8 V, VDDIO = 1.8V, TA=25°C, unless otherwise noted.

PARAMETERS	CONDITIONS	VDDIO < 1.71V		VDDIO ≥ 1.71V		UNITS	NOTES
		MIN	MAX	MIN	MAX		
SPI TIMING							
f _{SPC} , SCLK Clock Frequency	Default		20		24	MHz	1
t _{LOW} , SCLK Low Period		23.5		17		ns	1
t _{HIGH} , SCLK High Period		22.5		17		ns	1
t _{SU,CS} , CS Setup Time		17		17		ns	1
t _{HD,CS} , CS Hold Time		5		5		ns	1
t _{SU,SDIO} , SDIO Input Setup Time		13		13		ns	1
t _{HD,SDIO} , SDIO Input Hold Time		8		8		ns	1
t _{VD,SDIO} , SDIO Output Valid Time	C _{load} = 20 pF		18.5		18.5	ns	1
t _{HD,SDIO} , SDIO Output Hold Time	C _{load} = 20 pF	3.5		3.5		ns	1
t _{DIS,SDIO} , SDIO Output Disable Time			28		28	ns	1

Table 8. 3-Wire SPI Timing Characteristics

Notes:

1. Based on characterization of 5 parts over temperature and voltage as mounted on evaluation board or in sockets

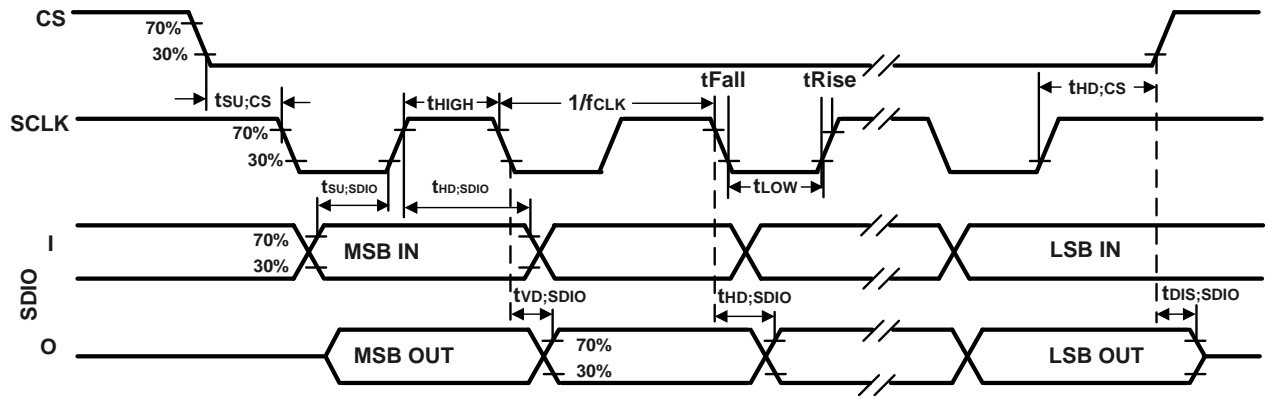

Figure 3. 3-Wire SPI Bus Timing Diagram

3.7 ABSOLUTE MAXIMUM RATINGS

Stress above those listed as “Absolute Maximum Ratings” may cause permanent damage to the device. These are stress ratings only and functional operation of the device at these conditions is not implied. Exposure to the absolute maximum ratings conditions for extended periods may affect device reliability.

Parameter	Rating
Supply Voltage, VDD	-0.5 V to +4 V
Supply Voltage, VDDIO	-0.5 V to +4 V
Input Voltage Level (FSYNC, SCL, SDA)	-0.5 V to VDDIO + 0.5 V
Acceleration (Any Axis, unpowered)	20,000g for 0.2 ms
Operating Temperature Range	-40°C to +85°C
Storage Temperature Range	-40°C to +125°C
Electrostatic Discharge (ESD) Protection	2 kV (HBM); 500 V (CDM)
Latch-up	JEDEC Class II (2) for VDDIO ≤ 1.98V, JEDEC Class I (1) for VDDIO > 1.98V, ±100 mA

Table 9. Absolute Maximum Ratings

4 APPLICATIONS INFORMATION

4.1 PIN OUT DIAGRAM AND SIGNAL DESCRIPTION

Pin Number	Pin Name	Single Interface Mode	Dual Interface I ² C Master Mode	Notes
1	AP_SDO / AP_ADO	AP_SDO: AP SPI serial data output (4-wire mode); AP_ADO: AP I ³ C SM / I ² C slave address LSB	AP_SDO: AP SPI serial data output (4-wire mode); AP_ADO: AP I ³ C SM / I ² C slave address LSB	<p>By default, internal pull-up is enabled. The internal weak pull-up is not strong enough to replace a pull-up resistor usually used on an open-drain bus. This pin supports both internal pull up and pull-down functionality. Internal pull up/down is controlled by two registers <code>pads_ap_sdo_pe_trim_d2a[0]</code> and <code>pads_ap_sdo_pud_trim_d2a[0]</code>. Internal pull-up can be disabled (enabled) by configuring <code>pads_ap_sdo_pe_trim_d2a[0] = 0 (1)</code> and internal pull direction down (up) can be set by <code>pads_ap_sdo_pud_trim_d2a[0] = 0 (1)</code>.</p> <p>If the AP interface is active, the internal pull-up should be disabled by setting <code>pads_ap_sdo_pe_trim_d2a[0] = 0</code>.</p>
2	RESV / MAS_DA	RESV: No Connect or Connect to VDDIO or Connect to GND	MAS_DA: I ² C serial master data	<p>By default, internal pull-up is enabled. The internal weak pull-up is not strong enough to replace a pull-up resistor usually used on an open-drain bus. This pin supports both internal pull up and pull-down functionality. Internal pull up/down is controlled by two registers <code>pads_aux1_sdi_pe_trim_d2a[0]</code> and <code>pads_aux1_sdi_pud_trim_d2a[0]</code>. Internal pull-up can be disabled (enabled) by configuring <code>pads_aux1_sdi_pe_trim_d2a[0] = 0 (1)</code> and internal pull direction down (up) can be set by <code>pads_aux1_sdi_pud_trim_d2a[0] = 0 (1)</code>.</p> <p>If the AUX1 interface is active, the internal pull-up should be disabled by setting <code>pads_aux1_sdi_pe_trim_d2a[0] = 0</code>.</p> <p>If pin2 is no connect, leave <code>pads_aux1_sdi_pe_trim_d2a[0] = 1</code>. If pin2 is connected to VDDIO or GND, disable internal pull-up by setting <code>pads_aux1_sdi_pe_trim_d2a[0] = 0</code>.</p>
3	RESV / MAS_CLK	RESV: No Connect or Connect to VDDIO or Connect to GND	MAS_CLK: I ² C serial master clock	<p>By default, internal pull-up is enabled. The internal weak pull-up is not strong enough to replace a pull-up resistor usually used on an open-drain bus. This pin supports both internal pull up and pull-down functionality. Internal pull up/down is controlled by two registers <code>pads_aux1_sclk_pe_trim_d2a[0]</code> and <code>pads_aux1_sclk_pud_trim_d2a[0]</code>. Internal pull-up can be disabled (enabled) by configuring <code>pads_aux1_sclk_pe_trim_d2a[0] = 0 (1)</code> and internal pull direction down (up) can be set by <code>pads_aux1_sclk_pud_trim_d2a[0] = 0 (1)</code>.</p> <p>If the AUX1 interface is active, the internal pull-up should be disabled by setting <code>pads_aux1_sclk_pe_trim_d2a[0] = 0</code>.</p> <p>If pin3 is no connect, leave <code>pads_aux1_sclk_pe_trim_d2a[0] = 1</code>. If pin3 is connected to VDDIO or GND, disable internal pull-up by setting <code>pads_aux1_sclk_pe_trim_d2a[0] = 0</code>.</p>
4	INT1 / INT	INT1: Interrupt 1 (Note: INT1 can be push-pull or open drain); INT: All	INT1: Interrupt 1 (Note: INT1 can be push-pull or open drain); INT: All interrupts mapped to pin 4	<p>By default, internal pull-up is disabled. The internal weak pull-up is not strong enough to replace a pull-up resistor usually used on an open-drain bus. This pin supports both internal</p>

		interrupts mapped to pin 4		pull up and pull-down functionality. Internal pull up/down is controlled by two registers pads_int1_pe_trim_d2a[0] and pads_int1_pud_trim_d2a[0]. Internal pull can be disabled (enabled) by configuring pads_int1_pe_trim_d2a[0] = 0 (1) and internal pull direction down (up) can be set by pads_int1_pud_trim_d2a[0] = 0 (1).
5	VDDIO	VDDIO: IO power supply voltage	VDDIO: IO power supply voltage	
6	GND	GND: Power supply ground	GND: Power supply ground	
7	RESV	RESV: No Connect or Connect to VDDIO or Connect to GND	RESV: No Connect or Connect to VDDIO or Connect to GND	<p>By default, internal pull-up is enabled. The internal weak pull-up is not strong enough to replace a pull-up resistor usually used on an open-drain bus. This pin supports both internal pull up and pull-down functionality. Internal pull up/down is controlled by two registers pads_pin7_pe_trim_d2a[0] and pads_pin7_cs_pud_trim_d2a[0]. Internal pull can be disabled (enabled) by configuring pads_pin7_pe_trim_d2a[0] = 0 (1) and internal pull direction down (up) can be set by pads_pin7_cs_pud_trim_d2a[0] = 0 (1).</p> <p>If pin7 is no connect, leave pads_pin7_pe_trim_d2a[0] = 1. If pin7 is connected to VDDIO or GND, disable internal pull-up by setting pads_pin7_pe_trim_d2a[0] = 0.</p>
8	VDD	VDD: Power supply voltage	VDD: Power supply voltage	
9	INT2 / FSYNC	INT2: Interrupt 2 (Note: INT2 can be push-pull or open drain); FSYNC: Frame sync input; If pin not used, can be No Connect or Connect to VDDIO	INT2: Interrupt 2 (Note: INT2 can be push-pull or open drain); FSYNC: Frame sync input; If pin not used, can be No Connect or Connect to VDDIO	<p>By default, internal pull-up is enabled. The internal weak pull-up is not strong enough to replace a pull-up resistor usually used on an open-drain bus. This pin supports both internal pull up and pull-down functionality. Internal pull up/down is controlled by two registers pads_int2_pe_trim_d2a[0] and pads_int2_pud_trim_d2a[0]. Internal pull-up can be disabled (enabled) by configuring pads_int2_pe_trim_d2a[0] = 0 (1) and internal pull direction down (up) can be set by pads_int2_pud_trim_d2a[0] = 0 (1).</p> <p>If pin9 is no connect, leave pads_int2_pe_trim_d2a[0] = 1. If pin9 is connected as an I/O, disable internal pull-up by setting pads_int2_pe_trim_d2a[0] = 0.</p>
10	RESV	RESV: No Connect or Connect to VDDIO or Connect to GND	RESV: No Connect or Connect to VDDIO or Connect to GND	<p>By default, internal pull-up is enabled. The internal weak pull-up is not strong enough to replace a pull-up resistor usually used on an open-drain bus. This pin supports both internal pull up and pull-down functionality. Internal pull up/down is controlled by two registers pads_aux1_cs_pe_trim_d2a[0] and pads_aux1_cs_pud_trim_d2a[0]. Internal pull-up can be disabled (enabled) by configuring pads_aux1_cs_pe_trim_d2a[0] = 0 (1) and internal pull direction down (up) can be set by pads_aux1_cs_pud_trim_d2a[0] = 0 (1).</p> <p>If the AUX1 interface is active, the internal pull-up should be disabled by setting pads_aux1_cs_pe_trim_d2a[0] = 0. If pin10 is no connect, leave pads_aux1_cs_pe_trim_d2a[0] = 1. If pin10 is connected to VDDIO or GND, disable internal pull-up by setting pads_aux1_cs_pe_trim_d2a[0] = 0.</p>
11	RESV	RESV: No Connect or Connect to VDDIO or Connect to GND	RESV: No Connect or Connect to VDDIO or Connect to GND	By default, internal pull-up is enabled. The internal weak pull-up is not strong enough to replace a pull-up resistor usually used on an open-drain bus. This pin supports both internal pull up and pull-down functionality. Internal pull up/down is controlled by two registers

				<p>pads_aux1_sdo_pe_trim_d2a[0] and pads_aux1_sdo_pud_trim_d2a[0]. Internal pull-up can be disabled (enabled) by configuring pads_aux1_sdo_pe_trim_d2a[0] = 0 (1) and internal pull direction down (up) can be set by pads_aux1_sdo_pud_trim_d2a[0] = 0 (1).</p> <p>If AUX1 interface is active, the internal pull-up should be disabled by setting pads_aux1_sdo_pe_trim_d2a[0] = 0. If pin11 is no connect, leave pads_aux1_sdo_pe_trim_d2a[0] = 1. If pin11 is connected to VDDIO or GND, disable internal pull-up by setting pads_aux1_sdo_pe_trim_d2a[0] = 0.</p>
12	AP_CS	AP_CS: AP SPI Chip select (AP SPI interface); Connect to VDDIO if using AP I3C SM / I ² C interface	AP_CS: AP SPI Chip select (AP SPI interface); Connect to VDDIO if using AP I3C SM / I ² C interface	<p>By default, internal pull-up is enabled. The internal weak pull-up is not strong enough to replace a pull-up resistor usually used on an open-drain bus. This pin supports both internal pull up and pull-down functionality. Internal pull up/down is controlled by two registers pads_ap_cs_pe_trim_d2a[0] and pads_ap_cs_pud_trim_d2a[0]. Internal pull can be disabled (enabled) by configuring pads_ap_cs_pe_trim_d2a[0] = 0 (1) and internal pull direction down (up) can be set by pads_ap_cs_pud_trim_d2a[0] = 0 (1).</p> <p>If the AP interface is active, the internal pull-up should be disabled by setting pads_ap_cs_pe_trim_d2a[0] = 0.</p>
13	AP_SCL / AP_SCLK	AP_SCL: AP I3C SM / I ² C serial clock; AP_SCLK: AP SPI serial clock	AP_SCL: AP I3C SM / I ² C serial clock; AP_SCLK: AP SPI serial clock	<p>By default, internal pull-up is enabled. The internal weak pull-up is not strong enough to replace a pull-up resistor usually used on an open-drain bus. This pin supports both internal pull up and pull-down functionality. Internal pull up/down is controlled by two registers pads_ap_sclk_pe_trim_d2a[0] and pads_ap_sclk_pud_trim_d2a[0]. Internal pull can be disabled (enabled) by configuring pads_ap_sclk_pe_trim_d2a[0] = 0 (1) and internal pull direction down (up) can be set by pads_ap_sclk_pud_trim_d2a[0] = 0 (1).</p> <p>If the AP interface is active, the internal pull-up should be disabled by setting pads_ap_sclk_pe_trim_d2a[0] = 0.</p>
14	AP_SDA / AP_SDIO / AP_SDI	AP_SDA: AP I3C SM / I ² C serial data; AP_SDIO: AP SPI serial data I/O (3-wire mode); AP_SDI: AP SPI serial data input (4-wire mode)	AP_SDA: AP I3C SM / I ² C serial data; AP_SDIO: AP SPI serial data I/O (3-wire mode); AP_SDI: AP SPI serial data input (4-wire mode)	<p>By default, internal pull-up is enabled. The internal weak pull-up is not strong enough to replace a pull-up resistor usually used on an open-drain bus. This pin supports both internal pull up and pull-down functionality. Internal pull up/down is controlled by two registers pads_ap_sdi_pe_trim_d2a[0] and pads_ap_sdi_pud_trim_d2a[0]. Internal pull can be disabled (enabled) by configuring pads_ap_sdi_pe_trim_d2a[0] = 0 (1) and internal pull direction down (up) can be set by pads_ap_sdi_pud_trim_d2a[0] = 0 (1).</p> <p>If the AP interface is active, the internal pull-up should be disabled by setting pads_ap_sdi_pe_trim_d2a[0] = 0.</p>

Table 10. Signal Descriptions

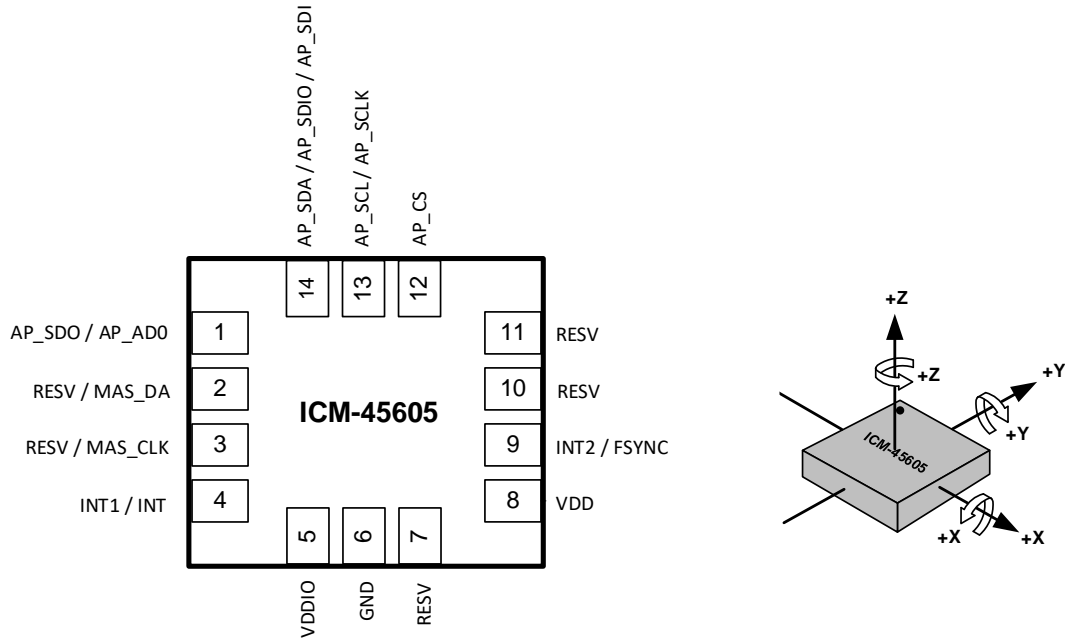
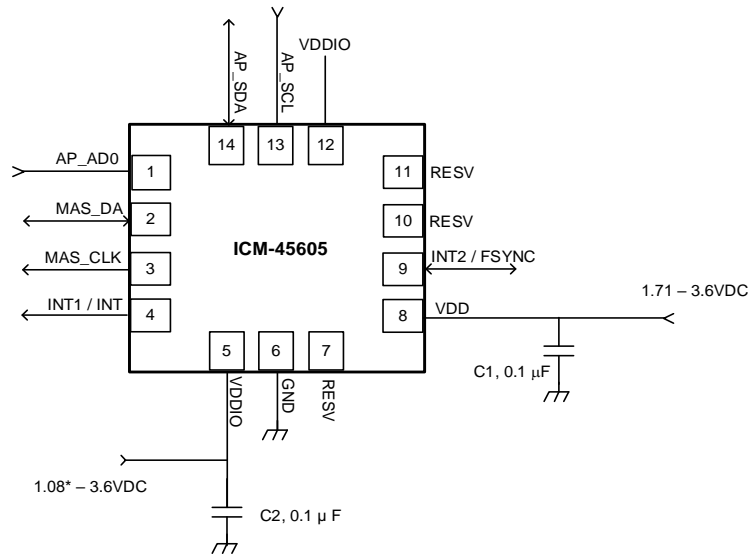

Figure 4. Pin Out Diagram for ICM-45605 2.5x3.0x0.81 mm LGA

4.2 TYPICAL OPERATING CIRCUIT (DUAL INTERFACE I²C MASTER MODE)



* Important Note: When using I3CSM interface the minimum VDDIO value is 1.1V.

Figure 5. ICM-45605 Application Schematic Dual Interface I²C Master Mode (I3CSM / I²C Interface to Host)

Note: I²C lines are open drain and pull-up resistors (e.g. 10 kΩ) are required.

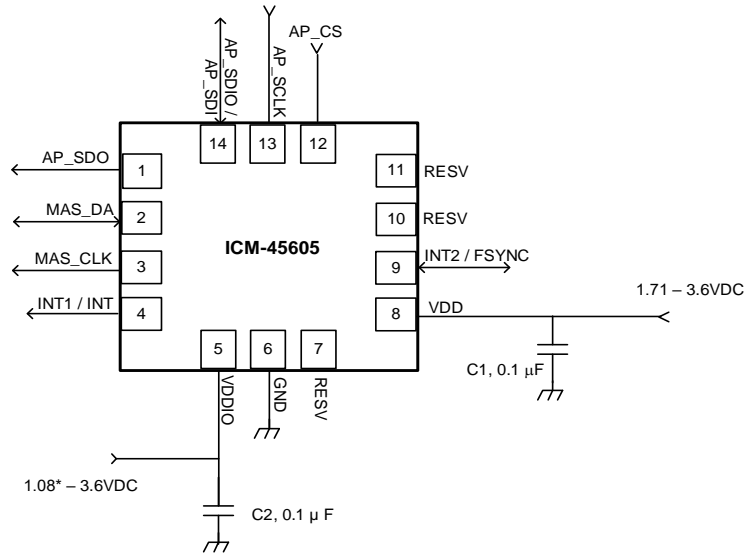

* Important Note: When using I3CSM interface the minimum VDDIO value is 1.1V.

Figure 6. ICM-45605 Application Schematic Dual Interface I²C Master Mode (SPI Interface to Host)

4.3 TYPICAL OPERATING CIRCUIT (SINGLE INTERFACE MODE)

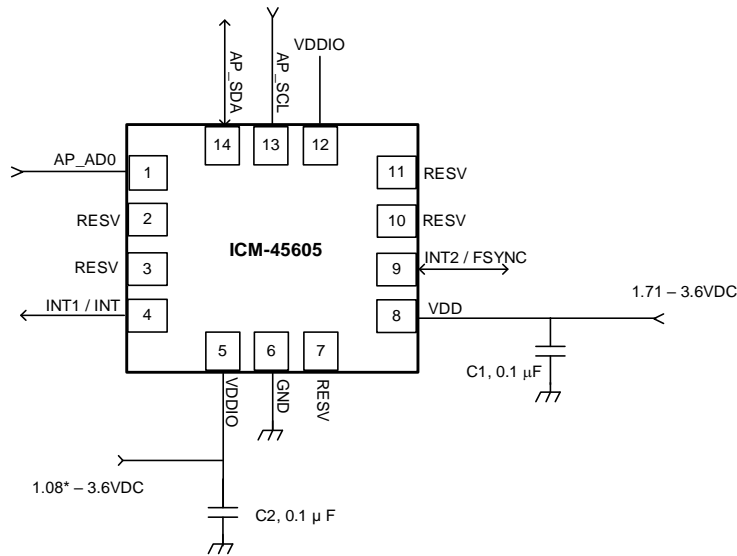

* Important Note: When using I3CSM interface the minimum VDDIO value is 1.1V.

Figure 7. ICM-45605 Application Schematic Single Interface Mode (I3CSM / I²C Interface to Host)

Note: I²C lines are open drain and pull-up resistors (e.g. 10 kΩ) are required.

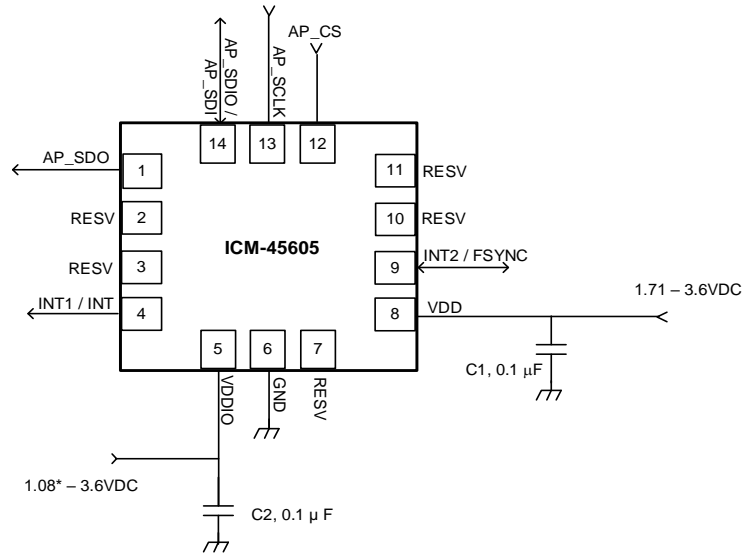

* Important Note: When using I3CSM interface the minimum VDDIO value is 1.1V.

Figure 8. ICM-45605 Application Schematic Single Interface Mode (SPI Interface to Host)

4.4 BILL OF MATERIALS FOR EXTERNAL COMPONENTS

Component	Label	Specification	Quantity
VDD Bypass Capacitor	C1	X7R, 0.1µF ±10%	1
VDDIO Bypass Capacitor	C2	X7R, 0.1µF ±10%	1

Table 11. Bill of Materials

Note: Use larger bypass capacitor than 0.1µF if power supply ripple exceeds 50mV peak-to-peak.

4.5 SYSTEM BLOCK DIAGRAM

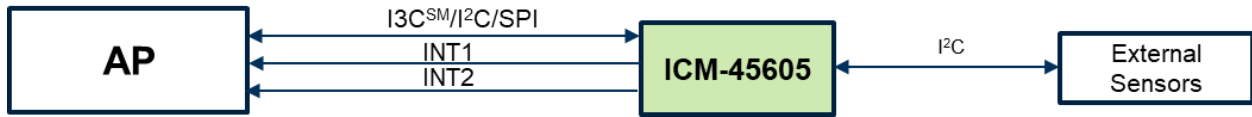

Figure 9. ICM-45605 System Block Diagram

Note: The above block diagram is an example. Please refer to the pin-out (section 4.1) for other configuration options.

4.6 OVERVIEW

The ICM-45605 is comprised of the following key blocks and functions:

- Three-axis MEMS rate gyroscope sensor with 16-bit ADCs and signal conditioning
 - 20-bits data format support in FIFO for high-data resolution (see section 5 for details)
- Three-axis MEMS accelerometer sensor with 16-bit ADCs and signal conditioning
 - 20-bits data format support in FIFO for high-data resolution (see section 5 for details)
- I3CSM, I²C and SPI Host Interface
- I²C Master Interface for connection to external sensors
- Self-Test
- Clocking
- Sensor Data Registers
- FIFO
- Interrupts
- Digital-Output Temperature Sensor
- Bias and LDOs
- Charge Pump
- Standard Power Modes

4.7 THREE-AXIS MEMS GYROSCOPE WITH 16-BIT ADCS AND SIGNAL CONDITIONING

The ICM-45605 includes a vibratory MEMS rate gyroscope, which detects rotation about the X-, Y-, and Z- Axes. When the gyroscope is rotated about any of the sense axes, the Coriolis Effect causes a vibration that is detected by a capacitive pickoff. The resulting signal is amplified, demodulated, and filtered to produce a voltage that is proportional to the angular rate. This voltage is digitized using on-chip Analog-to-Digital Converters (ADCs) to sample each axis. The full-scale range of the gyro sensors may be digitally programmed to ± 15.625 , ± 31.25 , ± 62.5 , ± 125 , ± 250 , ± 500 , ± 1000 , and ± 2000 degrees per second (dps).

4.8 THREE-AXIS MEMS ACCELEROMETER WITH 16-BIT ADCS AND SIGNAL CONDITIONING

The ICM-45605 includes a 3-Axis MEMS accelerometer. Acceleration along a particular axis induces displacement of a proof mass in the MEMS structure, and capacitive sensors detect the displacement. The ICM-45605 architecture reduces the accelerometers' susceptibility to fabrication variations as well as to thermal drift. When the device is placed on a flat surface, it will measure $0g$ on the X- and Y-axes and $+1g$ on the Z-axis. The accelerometers' scale factor is calibrated at the factory and is nominally independent of supply voltage. The full-scale range of the digital output can be adjusted to $\pm 2g$, $\pm 4g$, $\pm 8g$, and $\pm 16g$.

4.9 I3CSM, I²C AND SPI HOST INTERFACE

The ICM-45605 communicates to the application processor using an I3CSM, I²C, or SPI serial interface. The ICM-45605 always acts as a slave when communicating to the application processor.

4.10 I²C MASTER INTERFACE FOR CONNECTION TO EXTERNAL SENSORS

The ICM-45605 has an I²C master interface for connection to external sensors.

Up to 2 external sensors can be connected on this interface and their data read into the ICM-45605. I²C speed up to 400kHz is supported on the master interface. After I²C master finishes reading sensor data from the external sensor(s), the received sensor data is then reformatted by the internal processor (eDMP). The reformatted external sensor data is then moved into FIFO along with other internal sensor data. The external host reads the FIFO to retrieve both the external sensor data and the internal sensor data.

- Independent of the number of external devices on the I²C bus, the I²C master automatically executes up to 4 I²C transactions per trigger.
- The 4 I²C transactions are fully independent to each other.
- Each I²C transaction can be targeting any external I²C device (capped at 2 external I²C devices).
- Each I²C transaction can be a read or a write access transaction.
- Each I²C transaction can be a burst or a non-burst access transaction.
- A read transaction can be from an auto-incremented address location, or from a new address location.
- A read operation with a new address location consumes one of the 4 I²C transactions per trigger.

4.11 SELF-TEST

Self-test allows for the testing of the mechanical and electrical portions of the sensors. The self-test for each measurement axis can be activated by means of the gyroscope and accelerometer self-test registers.

When the self-test is activated, the electronics cause the sensors to be actuated and produce an output signal. The output signal is used to observe the self-test response.

The self-test response is defined as follows:

Self-test response = Sensor output with self-test enabled – Sensor output with self-test disabled

When the value of the self-test response is within the specified min/max limits of the product specification, the part has passed self-test. When the self-test response exceeds the min/max values, the part is deemed to have failed self-test.

4.12 CLOCKING

The ICM-45605 has a flexible clocking scheme, allowing internal clock sources to be used for the internal synchronous circuitry. This synchronous circuitry includes the signal conditioning and ADCs, and various control circuits and registers.

Allowable internal sources for generating the internal clock are:

- a) An internal relaxation oscillator
- b) Auto-select between internal relaxation oscillator and gyroscope MEMS oscillator to use the best available source

For internal sources, the only setting supporting specified performance in all modes is option b). It is recommended that option b) be used when using internal clock source.

4.13 SENSOR DATA REGISTERS

The sensor data registers contain the latest gyroscope, accelerometer, and temperature measurement data. They are read-only registers and are accessed via the serial interface. Data from these registers may be read anytime.

4.14 INTERRUPTS

Interrupt functionality is configured via the Interrupt Configuration register. Items that are configurable include the interrupt pins configuration, the interrupt latching and clearing method, and triggers for the interrupt. Items that can trigger an interrupt are (1) Clock generator locked to new reference oscillator (used when switching clock sources); (2) new data is available to be read (from the FIFO and Data registers); (3) accelerometer event interrupts; (4) FIFO watermark; (5) FIFO overflow. The interrupt status can be read from the Interrupt Status register.

4.15 DIGITAL-OUTPUT TEMPERATURE SENSOR

An on-chip temperature sensor and ADC are used to measure the ICM-45605 die temperature. The readings from the ADC can be read from the FIFO or the Sensor Data registers.

Temperature sensor register data TEMP_DATA is updated with new data at max (Accelerometer ODR, Gyroscope ODR).

4.16 BIAS AND LDOS

The bias and LDO section generates the internal supply and the reference voltages and currents required by the ICM-45605.

4.17 CHARGE PUMP

An on-chip charge pump generates the high voltage required for the MEMS oscillator.

4.18 STANDARD POWER MODES

The following table lists the user-accessible power modes for ICM-45605.

Name	Gyro	Accel
Sleep Mode	Off	Off
Standby Mode	Drive On	Off
Accelerometer Low-Power Mode	Off	Duty-Cycled
Accelerometer Ultra Low-Power Mode	Off	Duty-Cycled
Gyroscope Low-Power Mode	Duty-Cycled	Off
6-Axis Low-Power Mode	Duty-Cycled	Duty-Cycled
Accelerometer Low-Noise Mode	Off	On
Gyroscope Low-Noise Mode	On	Off
6-Axis Low-Noise Mode	On	On

Table 12. Standard Power Modes for ICM-45605

5 SIGNAL PATH

The following figure shows a block diagram of the signal path for ICM-45605.

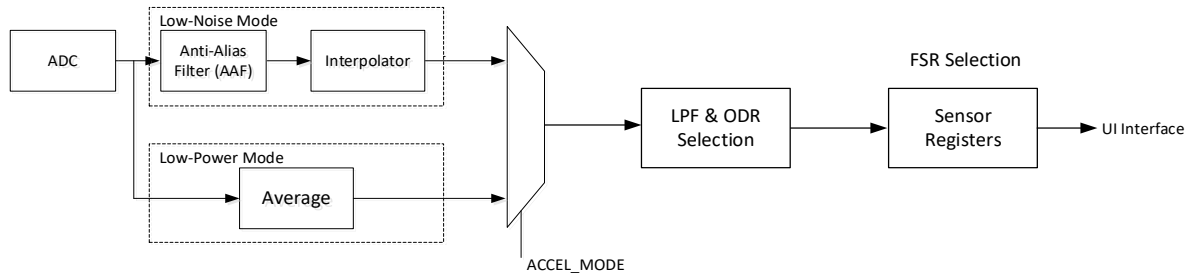

Figure 10. ICM-45605 Signal Path

The signal path starts with ADCs for the gyroscope and accelerometer. Low-Noise Mode and Low-Power Mode options are available for the gyroscope and accelerometer and are selectable using register fields GYRO_MODE and ACCEL_MODE respectively.

In Low-Noise Mode, the ADC output is sent through an Anti-Alias Filter (AAF). The AAF is an FIR filter with fixed coefficients (not user configurable). The AAF can be enabled or disabled by the user using GYRO_SRC_CTRL and ACCEL_SRC_CTRL.

The AAF is followed by an Interpolator. Sensor data can be re-timed using an interpolator when the user applies an external clock for higher ODR accuracy or operates the ICM-45605 in I3CSM synchronous mode. The Interpolator can be enabled or disabled by the user using GYRO_SRC_CTRL and ACCEL_SRC_CTRL.

In Low-Power Mode, the gyroscope and accelerometer ADC outputs are sent through Average filters, with user configurable average filter setting using register fields GYRO_LP_AVG_SEL and ACCEL_LP_AVG_SEL.

The output of Interpolator in Low-Noise Mode, or Average filter in Low-Power Mode is subject to UI LPF and ODR selection. The UI LPF BW is set by register bit field GYRO_UI_LPFBW_SEL and ACCEL_UI_LPFBW_SEL for gyroscope and accelerometer respectively. User selectable ODR is set using register fields GYRO_ODR and ACCEL_ODR. This is followed by Full Scale Range (FSR) selection based on user configurable settings for register fields GYRO_UI_FS_SEL and ACCEL_UI_FS_SEL.

6 FIFO

The ICM-45605 contains up to 8Kbytes FIFO (default FIFO size is 2Kbytes, user can extend it up to 8Kbytes by disabling APEX functions) that is accessible via the serial interface. The FIFO configuration register determines which data is written into the FIFO. Possible choices include gyroscope data, accelerometer data, temperature readings, and FSYNC input. A FIFO counter keeps track of how many bytes of valid data are contained in the FIFO.

ICM-45605 includes FIFO Compression algorithm that allows storing compressed sensor data in FIFO frames, thus virtually providing more FIFO space. It allows to store up to 4 times the number of frames with respect to non-compressed data. Frame decompression must be performed on the Host which reads the FIFO. Compression algorithm uses a hardware lossless algorithm, based on data variation analysis of each axis. Compression ratios x2, x3, x4 are supported, providing up to 32kByte data storage capability.

A 20-bit data format support is included in one of the FIFO packets structures. When the 20-bit data format is used, the gyroscope data consists of 20-bit of actual data, the accelerometer data consists of 19-bit of actual data and the LSB is always set to 0. Irrespective of the user-full scale selection, this high-resolution 20-bit data format is always scaled to ± 4000 dps (131.1 LSB/dps) for gyroscope and ± 32 g (16384 LSB/g) for accelerometer.

FIFO packet decimation capability is provided for additional storage optimization. User can configure the FIFO Data Rate (FDR) to control the decimation rate for writing packets to the FIFO. User must disable sensors when initializing FDR control value or making changes to it.

6.1 PACKET STRUCTURE

FIFO packets are assembled in different packet sizes based on the enabled sensors. When internal sensors Accel and Gyro are enabled, the following packets are available:

- 8 bytes packet: Contains Accel-only or Gyro-only data and Temperature data (1 byte)
- 16 bytes packet: Contains Accel data, Gyro data, Temperature data (1 byte), Timestamp
- 20 bytes packet: Contains high-resolution Accel data, Gyro data, Temperature data (2 bytes), Timestamp

The following figure shows packets organization for each format (big endian mode).

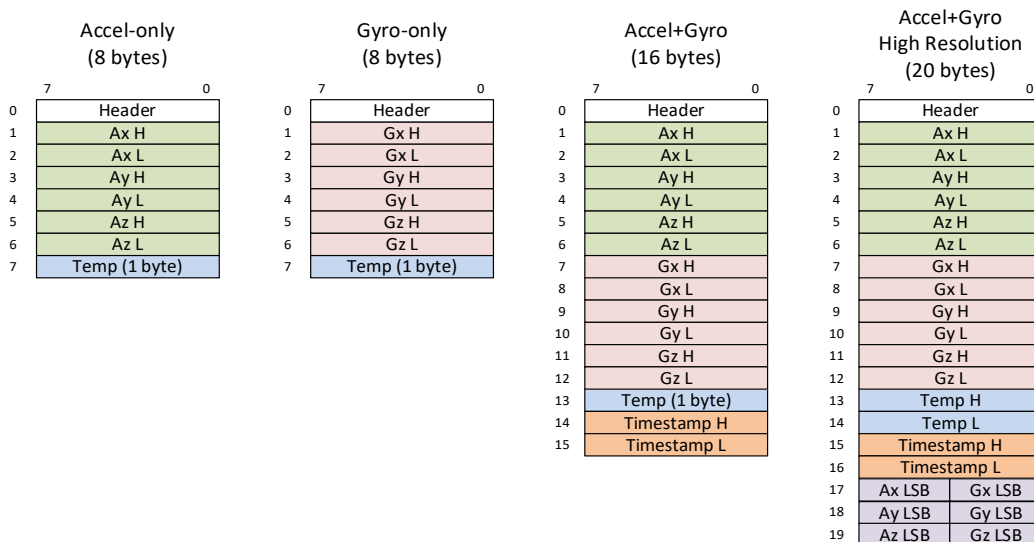

When external sensors ESO and ES1 are enabled, the following packets are available:

- 16 bytes packet: Contains 6/9 bytes ESO-only or ES1-only data
- 20 bytes frame: Contains 6/9 bytes ESO data and ES1 data
- 32 bytes frame: Contains Accel data, Gyro data, 6/9 bytes ESO data, ES1 data, Temperature data (1 byte), Timestamp. The 32 bytes format is always selected when at least one internal sensor and one external sensor are enabled

The following figure shows packets organization for each format (big endian mode).



6.2 FIFO HEADER

The following table shows the structure of the first byte of the FIFO header.

Bit Field	Item	Description
7	EXT_HEADER	1: FIFO header length is extended to 2 bytes. The second byte is used for compressed frame decoding fields or external sensors information 0: FIFO header length is 1 byte
6	ACCEL_EN	1: Accel is enabled or high resolution is enabled 0: Accel is not enabled and high resolution is not enabled
5	GYRO_EN	1: Gyro is enabled or high resolution is enabled 0: Gyro is not enabled and high resolution is not enabled
4	HIRES_EN	1: High-resolution is enabled (20-bytes format) 0: High-resolution is not enabled
3	TMST_FIELD_EN	1: Timestamp field is included in the packet. This requires that: a) high-resolution is enabled, or b) both Accel and Gyro are enabled, or c) either Accel or Gyro are enabled, and either ESO or ES1 are enabled The timestamp field contains the timestamp value or FSYNC-ODR delay depending on configuration 0: Timestamp field is not included in the packet
2	FSYNC_TAG_EN	1: FSYNC is triggered and the Timestamp field contains the FSYNC-ODR delay 0: FSYNC is not triggered and the Timestamp field does not contain the FSYNC-ODR delay

1	ACCEL_ODR	1: The ODR for accel is different for this accel data packet compared to the previous accel packet 0: The ODR for accel is the same as the previous packet with accel
0	GYRO_ODR	1: The ODR for gyro is different for this gyro data packet compared to the previous gyro packet 0: The ODR for gyro is the same as the previous packet with gyro

When External Sensors are enabled, an additional header byte is used. The second byte of the header is described below.

Bit Field	Item	Description
7:5	-	Reserved
4	ES0_6b_9b	Indicates how many bytes sensor ES0 provides 1: Sensor ES0 provides 9 bytes data 0: Sensor ES0 provides 6 bytes data
3	ES1_VLD	1: ES1 data is valid 0: ES1 data is not valid
2	ES0_VLD	1: ES0 data is valid 0: ES0 data is not valid
1	ES1_EN	1: Sensor ES1 is enabled 0: Sensor ES1 is not enabled
0	ES0_EN	1: Sensor ES0 is enabled 0: Sensor ES0 is not enabled

7 PROGRAMMABLE INTERRUPTS

The ICM-45605 has a programmable interrupt system that can generate an interrupt signal on the INT pins. Status flags indicate the source of an interrupt. Interrupt sources may be enabled and disabled individually. There are two interrupt outputs. Any interrupt may be mapped to either interrupt pin as explained in the register section. The following configuration options are available for the interrupts:

- INT1 and INT2 can be push-pull or open drain
- Level or pulse mode
- Active high or active low

Additionally, ICM-45605 includes In-band Interrupt (IBI) support for the I3CSM interface.

8 *EDMP*

The on-chip Enhanced Digital Motion Processor (EDMP) is designed for motion processing of next-gen sensor products. It enables ultra-low power run-time and offloads computation of motion processing and sensor fusion algorithms from the host processor. It enables the host system to execute custom algorithms and issue software interrupts to the external environment. The EDMP can be deployed in the system to minimize system level power, simplify the software architecture, and save valuable MIPS on the host processor. The EDMP implements a motion sensor optimized custom ISA with special motion processing instructions.

9 APEX MOTION FUNCTIONS

The APEX (Advanced Pedometer and Event Detection – neXt gen) features of ICM-45605 consist of:

- Pedometer: Tracks Step Count, also issues Step Detect interrupt.
- Tilt Detection: Issues an interrupt when the Tilt angle exceeds 35° for more than a programmable time.
- Raise to Wake/Sleep: Gesture detection for wake and sleep events. Interrupt is issued when either of these two events are detected.
- Single Tap / Double Tap Detection: Issues an interrupt when a tap is detected, along with the tap type.
- Wake on Motion: Detects motion when accelerometer data exceeds a programmable threshold. This motion event can be used to enable chip operation from sleep mode.
- Freefall Detection: Triggers an interrupt when device freefall is detected and outputs freefall duration.
- Significant Motion Detection: Detects significant motion based on accelerometer data.
- Low-G Detection: Triggers an interrupt when absolute value of accelerometer combined axis falls below a programmable threshold and stays below the threshold for a programmable time.
- High-G Detection: Triggers an interrupt when absolute value of accelerometer goes above a programmable threshold and stays above the threshold for a programmable time.

These functions are run as software on EDMP.

10 DIGITAL INTERFACE

10.1 I3CSM, I²C AND SPI SERIAL INTERFACES

The internal registers and memory of the ICM-45605 can be accessed using I3CSM at 12.5 MHz (data rates up to 12.5 Mbps in SDR mode, 25 Mbps in DDR mode), I²C at 1 MHz or SPI at 24 MHz. SPI operates in 3-wire or 4-wire mode. Pin assignments for serial interfaces are described in section 4.

10.2 I3CSM INTERFACE

I3CSM is a new 2-wire digital interface comprised of the signals serial data (SDA) and serial clock (SCLK). I3CSM is intended to improve upon the I²C interface, while preserving backward compatibility. The I3CSM capability of this device is compliant with Version 1.1.1 of the MIPI Alliance Specification for I3CSM. Please refer to the corresponding MIPI I3CSM specification for I3CSM timing information for this device.

I3CSM carries the advantages of I²C in simplicity, low pin count, easy board design, and multi-drop (vs. point to point), but provides the higher data rates, simpler pads, and lower power of SPI. I3CSM adds higher throughput for a given frequency, in-band interrupts (from slave to master), dynamic addressing.

ICM-45605 supports the following features of I3CSM:

- SDR data rate up to 12.5 Mbps
- DDR data rate up to 25 Mbps
- Dynamic address allocation
- In-band Interrupt (IBI) support
- Support for asynchronous timing control mode 0
- Error detection (CRC and/or Parity)
- Common Command Code (CCC)

The ICM-45605 always operates as an I3CSM slave device when communicating to the system processor, which thus acts as the I3CSM master. I3CSM master controls an active pullup resistance on SDA, which it can enable and disable. The pullup resistance may be a board level resistor controlled by a pin, or it may be internal to the I3CSM master.

The following table shows I3CSM Common Command Code (CCC) commands supported by the device.

CCC Description		Required or Optional per I3C v1.0	Supported by ICM-45605 Host Interface
1	ENEC, broadcast mode. (Enable Events).	Required	Yes
2	DISEC, broadcast mode. (Disable Events)	Required	Yes
3	ENTAS0, broadcast mode. (Enter Activity State 0)	Required	Yes
4	ENTAS1, broadcast mode. (Enter Activity State 1)	Optional	No
5	ENTAS2, broadcast mode. (Enter Activity State 0)	Optional	No
6	ENTAS3, broadcast mode. (Enter Activity State 0)	Optional	No
7	RSTDAA, broadcast mode. (Reset dynamic address assignment).	Required	Yes
8	ENTDAA, broadcast mode. (Enter dynamic address assignment).	Required	Yes

9	DEFSLVS, broadcast mode. (Define list of slaves).		Optional	No
10	SETMWL, broadcast mode. (Set Max Write Length).		Required	Yes
11	SETMRL, broadcast mode. (Set Max Read Length).		Required	Yes
12	ENTTM, broadcast mode. (Enter Test Mode).		Optional	No
13	ENTHDR0, broadcast mode. (Enter HDR DDR mode)		Optional	Yes
14	ENTHDR1, broadcast mode. (Enter HDR TSP mode)		Optional	No
15	ENTHDR2, broadcast mode. (Enter HDR TSL mode)		Optional	No
16	SETXTIME, broadcast mode. (Exchange Timing Information).			
	16.1	Defining byte = 0x7F (ST)	Optional	Yes
	16.2	Defining byte = 0xBF (DT)	Optional	Yes
	16.3	Defining byte = 0xDF (Enter Async Mode 0)	Optional	Yes
	16.4	Defining byte = 0xEF (Enter Async Mode 1)	Optional	No
	16.5	Defining byte = 0xF7 (Enter Async Mode 2)	Optional	No
	16.6	Defining byte = 0xFB (Enter Async Mode 3)	Optional	No
	16.7	Defining byte = 0xFD (Async Trigger for Async Mode 3).	Optional	No
	16.8	Defining byte = 0x3F (TPH)	Optional	Yes
	16.9	Defining byte = 0x9f (TU)	Optional	Yes
	16.10	Defining byte = 0x8F (ODR)	Optional	Yes
17	ENEC, direct mode. (Enable Events).		Required	Yes
18	DISEC, direct mode. (Disable Events).		Required	Yes
19	ENTAS0, direct mode. (Enter Activity State 0).		Required	Yes
20	ENTAS1, direct mode. (Enter Activity State 1).		Optional	No
21	ENTAS2, direct mode. (Enter Activity State 2).		Optional	No
22	ENTAS3, direct mode. (Enter Activity State 3).		Optional	No
23	RSTDAA, direct mode. (Reset dynamic address assignment).		Required	Yes
24	SETDASA, direct mode. (Set Dynamic address from static address).		Optional	Yes

25	SETNEWDA, direct mode. (Set new dynamic address)	Required	Yes
26	SETMWL, direct mode. (Set Max Write Length).	Required / Conditional	Yes
27	SETMRL, direct mode. (Set Max Read length).	Required / Conditional	Yes
28	GETMWL, direct mode. (Get Max write length).	Required / Conditional	Yes
29	GETMRL, direct mode. (Get Max Read length).	Required / Conditional	Yes
30	GETPID, direct mode. (Get provisional ID).	Required	Yes
31	GETBCR, direct mode. (Get Bus Characteristics Register).	Required	Yes
32	GETDCR, direct mode. (Get Device Characteristics Register).	Required	Yes
33	GETSTATUS, direct mode. (Get Device Status).	Required	Yes
34	GETACCMST, direct mode. (Get Accept Mastership).	Optional	No
35	SETBRGTGT, direct mode. (Set Bridge Targets).	Optional	No
36	GETMXDS, direct mod. (Get Max Data Speed).	Optional	Yes
37	GETHDCAP, direct mode. (Get HDR capability).	Optional	Yes
38	SETXTIME, direct mode. (Set Exchange Timing information).		
	38.1	Defining byte = 0x7F (ST)	Optional / Yes
	38.2	Defining byte = 0xBF (DT)	Optional / Yes
	38.3	Defining byte = 0xDF (Enter Async Mode 0)	Optional / Yes
	38.4	Defining byte = 0xEF (Enter Async Mode 1)	Optional / No
	38.5	Defining byte = 0xF7 (Enter Async Mode 2)	Optional / No
	38.6	Defining byte = 0xFB (Enter Async Mode 3)	Optional / No
	38.7	Defining byte = 0xFD (Async Trigger for Async Mode 3).	Optional / No
	38.8	Defining byte = 0x3F (TPH)	Optional / Yes
	38.9	Defining byte = 0x9f (TU)	Optional / Yes
	38.10	Defining byte = 0x8F (ODR)	Optional / Yes

	39 GETXTIME, direct mode. (Get Exchange Timing Information).	Optional	Yes
--	--	----------	-----

Table 13. I3CSM CCC Commands

10.3 I²C INTERFACE

I²C is a two-wire interface comprised of the signals serial data (SDA) and serial clock (SCL). In general, the lines are open-drain and bi-directional. In a generalized I²C interface implementation, attached devices can be a master or a slave. The master device puts the slave address on the bus, and the slave device with the matching address acknowledges the master.

The ICM-45605 always operates as a slave device when communicating to the system processor, which thus acts as the master. SDA and SCL lines typically need pull-up resistors to VDDIO. The maximum bus speed is 1 MHz.

The slave address of the ICM-45605 is b110100X, which is 7 bits long. The LSB bit of the 7-bit address is determined by the logic level on pin AP_AD0. This allows two ICM-45605s to be connected to the same I²C bus. When used in this configuration, the address of one of the devices should be b1101000 (pin AP_AD0 is logic low) and the address of the other should be b1101001 (pin AP_AD0 is logic high).

10.4 I²C MASTER INTERFACE

I²C master is compliant with the I²C standard-Mode (max 100kbps), and I²C Fast-Mode (max 400kbps). It supports 8-bit I²C static address. It does not support multi-master on the I²C bus. Clock-stretching by external I²C devices is not supported.

10.5 SPI INTERFACE

The ICM-45605 supports 3-wire or 4-wire SPI for the host interface. The ICM-45605 always operates as a Slave device during standard Master-Slave SPI operation.

With respect to the Master, the Serial Clock output (SCLK), the Serial Data Output (SDO), the Serial Data Input (SDI), and the Serial Data IO (SDIO) are shared among the Slave devices. Each SPI slave device requires its own Chip Select (CS) line from the master.

CS goes low (active) at the start of transmission and goes back high (inactive) at the end. Only one CS line is active at a time, ensuring that only one slave is selected at any given time. The CS lines of the non-selected slave devices are held high, causing their SDO lines to remain in a high-impedance (high-z) state so that they do not interfere with any active devices.

SPI Operational Features

1. Data is delivered MSB first and LSB last
2. Data is latched on the rising edge of SCLK
3. Data should be transitioned on the falling edge of SCLK
4. The maximum frequency of SCLK is 24 MHz (it is 20MHz at VDDIO 1.2V)
5. SPI read and write operations are completed in 16 or more clock cycles (two or more bytes). The first byte contains the Register Address, and the following byte(s) contain(s) the SPI data. The first bit of the first byte contains the Read/Write bit and indicates the Read (1) operation. The following 7 bits contain the Register Address. In cases of multiple-byte Reads, data is two or more bytes:

Register Address format

MSB							LSB
R/W	A6	A5	A4	A3	A2	A1	A0

SPI Data format

MSB							LSB
D7	D6	D5	D4	D3	D2	D1	D0

6. Supports Single or Burst Read/Writes.

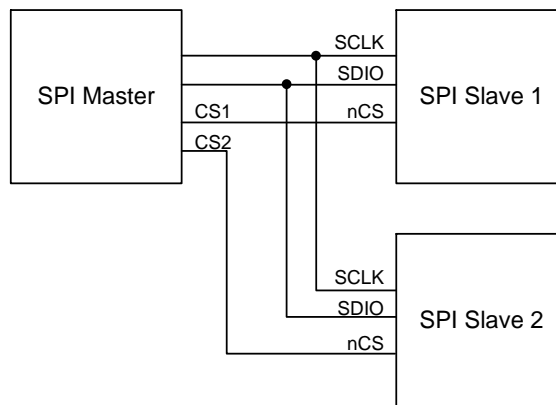

Figure 11. Typical SPI Master/Slave Configuration

11 ASSEMBLY

This section provides general guidelines for assembling InvenSense Micro Electro-Mechanical Systems (MEMS) devices packaged in LGA package.

11.1 ORIENTATION OF AXES

The diagram below shows the orientation of the axes of sensitivity and the polarity of rotation. Note the pin 1 identifier (•) in the figure.

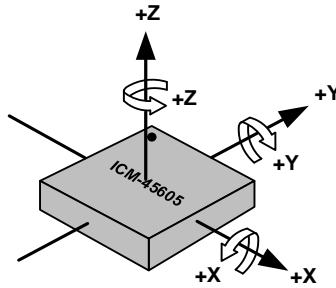
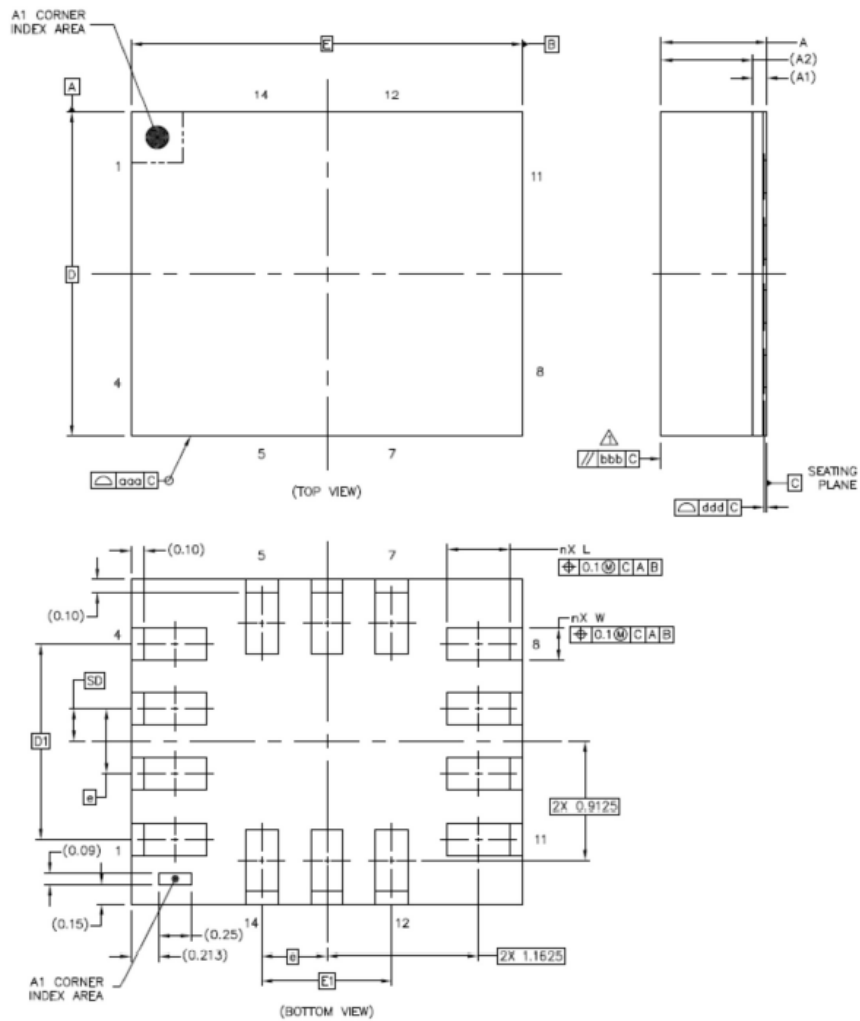

Figure 12. Orientation of Axes of Sensitivity and Polarity of Rotation

11.2 PACKAGE DIMENSIONS

14 Lead LGA (2.5x3x0.81) mm NiAu pad finish



	SYMBOLS	DIMENSIONS IN MILLIMETERS		
		MIN	NOM	MAX
Total Thickness	A	0.76	0.81	0.86
Substrate Thickness	A1	0.105		REF
Mold Thickness	A2	0.7		REF
Body Size	D		2.5	BSC
	E		3	BSC
Lead Width	W	0.2	0.25	0.3
Lead Length	L	0.425	0.475	0.525
Lead Pitch	e	0.5		BSC
Lead Count	n	14		
Edge Ball Center to Center	D1	1.5		BSC
	E1	1		BSC
Body Center to Contact Ball	SD	0.25		BSC
	SE	---		BSC
Package Edge Tolerance	aaa	0.1		
Mold Flatness	bbb	0.2		
Coplanarity	ddd	0.08		

12 DEVICE PACKAGE IN TAPE AND REEL

ICM-45605 devices are packaged in the tape and reel as shown in the figures below.

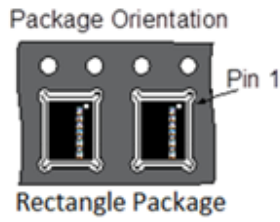

Figure 13. ICM-45605 Device Package in Tape and Reel

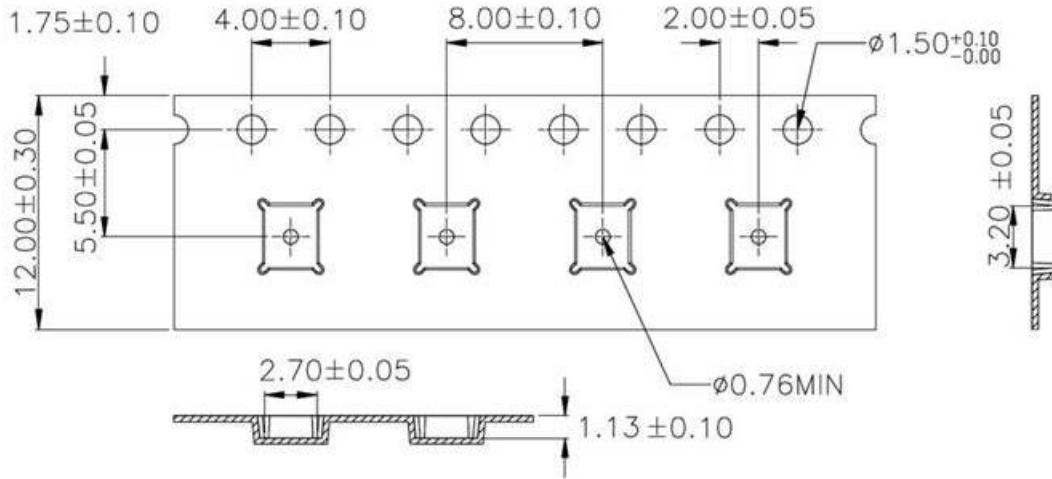
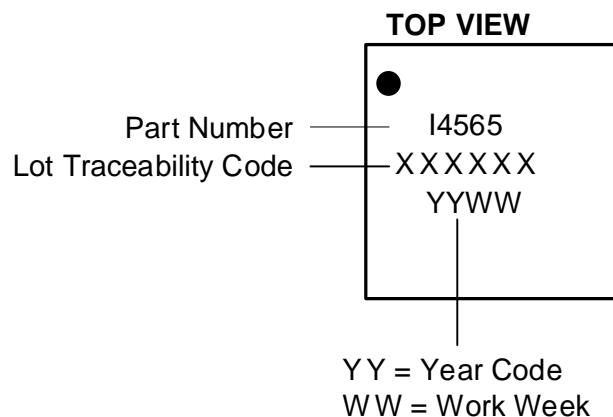

Figure 14. Tape Dimensions with ICM-45605 Device Package

13 PART NUMBER PACKAGE MARKING

The part number package marking for ICM-45605 devices is summarized below:

Part Number	Part Number Package Marking
ICM-45605	I4565



14 INDIRECT REGISTER ACCESS

14.1 HOST INDIRECT ACCESS REGISTER (IREG)

An IREG is a register or a memory storage element that is not addressed directly by a 7-bit address. IREGs can only be addressed using an internal 16-bit address. Indirect register access procedures described in this section must be used to access all IREGs.

The host configures the internal 16-bit address by programming following registers:
{ireg_addr_15_8[7:0], ireg_addr_7_0[7:0]}.

14.2 GENERAL RULES FOR ACCESSING IREG

1. Burst-write and burst-read operations are not supported when accessing IREGs from the host.
2. Reading of an IREG is done on a read-pre-fetch basis (details in IREG READ section below).
3. A minimum wait time (refer to section MINIMUM WAIT TIME GAP below for details) is required between two consecutive read/write access to an IREG.

14.3 MINIMUM WAIT TIME-GAP

The minimum time gap between two consecutive IREG accesses for various IREG components is 4 μ s.

14.4 IREG WRITE

Procedure for writing to an IREG.

1. The host specifies the destination address of an IREG by programming IREG_ADDR_7_0, IREG_ADDR_15_8.
 - a. If host wants to access a register in IMEM_SRAM, it should add base address 0x0000 to the address of that register shown in the IMEM_SRAM registers section, and then use that resulting value in registers IREG_ADDR_7_0, IREG_ADDR_15_8.
 - b. If host wants to access a register in IPREG_BAR, it should add base address 0xA000 to the address of that register shown in the IPREG_BAR registers section, and then use that resulting value in registers IREG_ADDR_7_0, IREG_ADDR_15_8.
 - c. If host wants to access a register in IPREG_SYS1, it should add base address 0xA400 to the address of that register shown in the IPREG_SYS1 registers section, and then use that resulting value in registers IREG_ADDR_7_0, IREG_ADDR_15_8.
 - d. If host wants to access a register in IPREG_SYS2, it should add base address 0xA500 to the address of that register shown in the IPREG_SYS2 registers section, and then use that resulting value in registers IREG_ADDR_7_0, IREG_ADDR_15_8.
 - e. If host wants to access a register in IPREG_TOP1, it should add base address 0xA200 to the address of that register shown in the IPREG_TOP1 registers section, and then use that resulting value in registers IREG_ADDR_7_0, IREG_ADDR_15_8.
2. The host programs the write data to the IREG_DATA register.
3. The above programming steps must be performed in a single burst-write transaction to prevent an unintended read-pre-fetch operation.
4. After the IREG_DATA register is written, an internal operation is triggered to pass the contents from the IREG_DATA register to a register pointed by {IREG_ADDR_7_0, IREG_ADDR_15_8}.
5. After the contents from the IREG_DATA register is written to the selected register, the internal 16-bit address is auto-incremented.
6. After a minimum wait time-gap, the host can write to the IREG_DATA register again, which is effectively writing to the register pointed by the post-auto-incremented address.
7. Or, after a minimum wait time-gap, the host can program a new destination address for the next write operation.

14.5 IREG READ

Procedure for reading from an IREG.

1. The host specifies the destination address of an IREG by programming IREG_ADDR_7_0, IREG_ADDR_15_8.
 - a. If host wants to access a register in IMEM_SRAM, it should add base address 0x0000 to the address of that register shown in the IMEM_SRAM registers section, and then use that resulting value in registers IREG_ADDR_7_0, IREG_ADDR_15_8.
 - b. If host wants to access a register in IPREG_BAR, it should add base address 0xA000 to the address of that register shown in the IPREG_BAR registers section, and then use that resulting value in registers IREG_ADDR_7_0, IREG_ADDR_15_8.
 - c. If host wants to access a register in IPREG_SYS1, it should add base address 0xA400 to the address of that register shown in the IPREG_SYS1 registers section, and then use that resulting value in registers IREG_ADDR_7_0, IREG_ADDR_15_8.
 - d. If host wants to access a register in IPREG_SYS2, it should add base address 0xA500 to the address of that register shown in the IPREG_SYS2 registers section, and then use that resulting value in registers IREG_ADDR_7_0, IREG_ADDR_15_8.
 - e. If host wants to access a register in IPREG_TOP1, it should add base address 0xA200 to the address of that register shown in the IPREG_TOP1 registers section, and then use that resulting value in registers IREG_ADDR_7_0, IREG_ADDR_15_8.
2. Upon the CSB=1 (SPI) or STOP (I2C) after the above programming, an internal read-pre-fetch operation is triggered.
3. The internal read-pre-fetch operation returns the desired data, which is saved to the IREG_DATA register.
4. After a minimum wait time-gap, the host reads the IREG_DATA register to retrieve the read-data.
5. After the host reads the IREG_DATA register, the internal 16-bit address is auto-incremented, and another internal read-pre-fetch is automatically triggered, to fetch data from the IREG register pointed to by the post-auto-incremented address.
6. After a minimum wait time-gap, the host can either read the IREG_DATA register to get the read-data from the next address location, or it can program a new read address.

15 DEVICE CONFIGURATION FOR DATA ENDIANNES

By default the device data endianness is Little Endian, for data in Sensor Data Registers and FIFO, and for FIFO Count. User must set register field SREG_DATA_ENDIAN_SEL in register SREG_CTRL to 1, to enable Big Endian data format for data in Sensor Data Registers and FIFO, and for FIFO Count.

Data descriptions in the register map for Sensor Data Registers, FIFO data, and FIFO Count are for the commonly used Big Endian format.

16 REGISTER MAP

This section lists the register map for the ICM-45605, for user bank 0, IMEM_SRAM, IPREG_BAR, IPREG_TOP1, IPREG_SYS1, IPREG_SYS2.

Please refer to the procedure in Section 14 for configuring device data endianness before using the register map.

16.1 USER BANK 0 REGISTER MAP

Addr (Hex)	Addr (Dec.)	Register Name	Serial I/F	Bit7	Bit6	Bit5	Bit4	Bit3	Bit2	Bit1	Bit0	
00	00	ACCEL_DATA_X1_UI	SYNCR	ACCEL_DATA_X_UI[15:8]								
01	01	ACCEL_DATA_X0_UI	SYNCR	ACCEL_DATA_X_UI[7:0]								
02	02	ACCEL_DATA_Y1_UI	SYNCR	ACCEL_DATA_Y_UI[15:8]								
03	03	ACCEL_DATA_Y0_UI	SYNCR	ACCEL_DATA_Y_UI[7:0]								
04	04	ACCEL_DATA_Z1_UI	SYNCR	ACCEL_DATA_Z_UI[15:8]								
05	05	ACCEL_DATA_Z0_UI	SYNCR	ACCEL_DATA_Z_UI[7:0]								
06	06	GYRO_DATA_X1_UI	SYNCR	GYRO_DATA_X_UI[15:8]								
07	07	GYRO_DATA_X0_UI	SYNCR	GYRO_DATA_X_UI[7:0]								
08	08	GYRO_DATA_Y1_UI	SYNCR	GYRO_DATA_Y_UI[15:8]								
09	09	GYRO_DATA_Y0_UI	SYNCR	GYRO_DATA_Y_UI[7:0]								
0A	10	GYRO_DATA_Z1_UI	SYNCR	GYRO_DATA_Z_UI[15:8]								
0B	11	GYRO_DATA_Z0_UI	SYNCR	GYRO_DATA_Z_UI[7:0]								
0C	12	TEMP_DATA1_UI	SYNCR	TEMP_DATA_UI[15:8]								
0D	13	TEMP_DATA0_UI	SYNCR	TEMP_DATA_UI[7:0]								
0E	14	TMST_FSYNCH	SYNCR	TMST_FSYNCH_DATA_UI[15:8]								
0F	15	TMST_FSYNCL	SYNCR	TMST_FSYNCH_DATA_UI[7:0]								
10	16	PWR_MGMT0	R/W	-				GYRO_MODE		ACCEL_MODE		
12	18	FIFO_COUNT_0	R	FIFO_DATA_CNT[15:8]								
13	19	FIFO_COUNT_1	R	FIFO_DATA_CNT[7:0]								
14	20	FIFO_DATA	R	FIFO_DATA								
16	22	INT1_CONFIG0	R/W	INT1_STATUS_EN_RESET_DONE	INT1_STATUS_EN_AUX1_AGC_RDY	INT1_STATUS_EN_AP_AGC_RDY	INT1_STATUS_EN_AP_FSYNC	INT1_STATUS_EN_AUX1_DRDY	INT1_STATUS_EN_DRDY	INT1_STATUS_EN_FIFO_THS	INT1_STATUS_EN_FIFO_FULL	
17	23	INT1_CONFIG1	R/W	-	INT1_STATUS_EN_APEX_EVENT	INT1_STATUS_EN_I2CM_DONE	INT1_STATUS_EN_I3C_PROTOCOL_ERR	INT1_STATUS_EN_WOM_Z	INT1_STATUS_EN_WOM_Y	INT1_STATUS_EN_WOM_X	INT1_STATUS_EN_PLL_RDY	
18	24	INT1_CONFIG2	R/W	-						INT1_DRIVE	INT1_MODE	INT1_POLARITY
19	25	INT1_STATUS0	R/C	INT1_STATUS_RESET_DONE	INT1_STATUS_AUX1_AGC_RDY	INT1_STATUS_AP_AGC_RDY	INT1_STATUS_AP_FSYNC	INT1_STATUS_AUX1_DRDY	INT1_STATUS_DRDY	INT1_STATUS_FIFO_THS	INT1_STATUS_FIFO_FULL	
1A	26	INT1_STATUS1	R/C	-	INT1_STATUS_APEX_EVENT	INT1_STATUS_I2CM_DONE	INT1_STATUS_I3C_PROTOCOL_ERR	INT1_STATUS_WOM_Z	INT1_STATUS_WOM_Y	INT1_STATUS_WOM_X	INT1_STATUS_PLL_RDY	
1B	27	ACCEL_CONFIG0	R/W	-	ACCEL_UI_FS_SEL			ACCEL_ODR				
1C	28	GYRO_CONFIG0	R/W	GYRO_UI_FS_SEL				GYRO_ODR				
1D	29	FIFO_CONFIG0	R/W	FIFO_MODE			FIFO_DEPTH					
1E	30	FIFO_CONFIG1_0	R/W	FIFO_WM_TH[7:0]								
1F	31	FIFO_CONFIG1_1	R/W	FIFO_WM_TH[15:8]								
20	32	FIFO_CONFIG2	R/W	FIFO_FLUSH	-			FIFO_WR_WM_GT_TH	-			
21	33	FIFO_CONFIG3	R/W	-		FIFO_ES1_EN	FIFO_ES0_EN	FIFO_HIRES_EN	FIFO_GYRO_EN	FIFO_ACCEL_EN	FIFO_IF_EN	
22	34	FIFO_CONFIG4	R/W	-		FIFO_COMP_NC_FLOW_CFG			FIFO_COMP_EN	FIFO_TMST_FSYNC_EN	FIFO_ES0_6B_9B	
23	35	TMST_WOM_CONFIG	R/W	-	TMST_DELTA_EN	TMST_RESOL	WOM_EN	WOM_MODE	WOM_INT_MODE	WOM_INT_DUR		

Addr (Hex)	Addr (Dec.)	Register Name	Serial I/F	Bit7	Bit6	Bit5	Bit4	Bit3	Bit2	Bit1	Bit0	
24	36	FSYNC_CONFIG0	R/W	-				AP_FSYNC_FL AG_CLEAR_SEL	AP_FSYNC_SEL			
27	39	DMP_EXT_SEN_ODR_CFG	R/W	-	EXT_SENSOR_EN	EXT_ODR			APEX_ODR			
28	40	ODR_DECIMATE_CONFIG	R/W	GYRO_FIFO_ODR_DEC				ACCEL_FIFO_ODR_DEC				
29	41	EDMP_APEX_EN0	R/W	SMD_EN	R2W_EN	FF_EN	PEDO_EN	TILT_EN	-		TAP_EN	
2A	42	EDMP_APEX_EN1	R/W	-	EDMP_ENABLE	FEATURE3_EN	-		POWER_SAVE_EN	INIT_EN	SOFT_HARD_IRON_CORR_EN	
2B	43	APEX_BUFFER_MGMT	R/W	FF_DURATION_HOST_RPTR		FF_DURATION_EDMP_WPTR		STEP_COUNT_HOST_RPTR		STEP_COUNT_EDMP_WPTR		
2C	44	INTF_CONFIG0	R/W	-							AP_SPI_34_MODE	AP_SPI_MODE
2D	45	INTF_CONFIG1_OVRD	R/W	-				AP_SPI_34_MODE_OVRD	AP_SPI_34_MODE_OVRD_VAL	AP_SPI_MODE_OVRD	AP_SPI_MODE_OVRD_VAL	
2F	47	IOC_PAD_SCENARIO	R	-					AUX1_MODE		AUX1_ENABLE	
30	48	IOC_PAD_SCENARIO_AUX_OVRD	R/W	-			AUX1_MODE_OVRD	AUX1_ENABLE_OVRD_VAL		AUX1_ENABLE_OVRD	AUX1_ENABLE_OVRD_VAL	
32	50	DRIVE_CONFIG0	R/W	-	PADS_I2C_SLEW			PADS_SPI_SLEW			-	
33	51	DRIVE_CONFIG1	R/W	-		PADS_I3C_DDR_SLEW			PADS_I3C_SDR_SLEW			
34	52	DRIVE_CONFIG2	R/W	-							PADS_SLEW	
35	53	REG_MISC1	R/W	-				OSC_ID_OVRD				
39	57	INT_APEX_CONFIG0	R/W	INT_STATUS_MASK_PIN_R2W_WAKE_DET	INT_STATUS_MASK_PIN_FF_DET	INT_STATUS_MASK_PIN_STEP_DET	INT_STATUS_MASK_PIN_STEP_CNT_OVFL	INT_STATUS_MASK_PIN_TILT_DET	INT_STATUS_MASK_PIN_LOW_G_DET	INT_STATUS_MASK_PIN_HIGH_G_DET	INT_STATUS_MASK_PIN_TAP_DET	
3A	58	INT_APEX_CONFIG1	R/W	-			INT_STATUS_MASK_PIN_SA_DONE	-	INT_STATUS_MASK_PIN_SELFTEST_DONE	INT_STATUS_MASK_PIN_SMD_DET	INT_STATUS_MASK_PIN_R2W_SLEEP_DET	
3B	59	INT_APEX_STATUS0	R/C	INT_STATUS_R2W_WAKE_DET	INT_STATUS_FF_DET	INT_STATUS_STEP_DET	INT_STATUS_STEP_CNT_OVFL	INT_STATUS_TILT_DET	INT_STATUS_LOW_G_DET	INT_STATUS_HIGH_G_DET	INT_STATUS_TAP_DET	
3C	60	INT_APEX_STATUS1	R/C	-			INT_STATUS_SA_DONE	-	INT_STATUS_SELFTEST_DONE	INT_STATUS_SMD_DET	INT_STATUS_R2W_SLEEP_DET	
56	86	INT2_CONFIG0	R/W	INT2_STATUS_EN_RESET_DONE	INT2_STATUS_EN_AUX1_AGC_RDY	INT2_STATUS_EN_AP_AGC_RDY	INT2_STATUS_EN_AP_FSYNC	INT2_STATUS_EN_AUX1_DRDY	INT2_STATUS_EN_DRDY	INT2_STATUS_EN_FIFO_THS	INT2_STATUS_EN_FIFO_FULL	
57	87	INT2_CONFIG1	R/W	-	INT2_STATUS_EN_APEX_EVENT	INT2_STATUS_EN_I2CM_DONE	INT2_STATUS_EN_I3C_PROTOCOL_ERR	INT2_STATUS_EN_WOM_Z	INT2_STATUS_EN_WOM_Y	INT2_STATUS_EN_WOM_X	INT2_STATUS_EN_PLL_RDY	
58	88	INT2_CONFIG2	R/W	-					INT2_DRIVE	INT2_MODE	INT2_POLARITY	
59	89	INT2_STATUS0	R/C	INT2_STATUS_RESET_DONE	INT2_STATUS_AUX1_AGC_RDY	INT2_STATUS_AP_AGC_RDY	INT2_STATUS_AP_FSYNC	INT2_STATUS_AUX1_DRDY	INT2_STATUS_DRDY	INT2_STATUS_FIFO_THS	INT2_STATUS_FIFO_FULL	
5A	90	INT2_STATUS1	R/C	-	INT1_STATUS_APEX_EVENT	INT1_STATUS_I2CM_DONE	INT1_STATUS_I3C_PROTOCOL_ERR	INT1_STATUS_WOM_Z	INT1_STATUS_WOM_Y	INT1_STATUS_WOM_X	INT1_STATUS_PLL_RDY	
72	114	WHO_AM_I	R	WHOAMI								
73	115	REG_HOST_MSG	R/W	-			EDMP_ON_DEMAND_EN	-			TESTOPENABLE	
7C	124	IREG_ADDR_15_8	R/W	IREG_ADDR_15_8								
7D	125	IREG_ADDR_7_0	R/W	IREG_ADDR_7_0								
7E	126	IREG_DATA	R/W	IREG_DATA								
7F	127	REG_MISC2	R/W	-							SOFT_RST	IREG_DONE

16.2 USER BANK IMEM_SRAM REGISTER MAP

Addr (Hex)	Addr (Dec.)	Register Name	Serial I/F	Bit7	Bit6	Bit5	Bit4	Bit3	Bit2	Bit1	Bit0	
00	00	IMEM_SRAM_REG_0	R/W	GYRO_X_STR_FT[7:0]								
01	01	IMEM_SRAM_REG_1	R/W	GYRO_X_STR_FT[15:8]								
02	02	IMEM_SRAM_REG_2	R/W	GYRO_Y_STR_FT[7:0]								
03	03	IMEM_SRAM_REG_3	R/W	GYRO_Y_STR_FT[15:8]								
04	04	IMEM_SRAM_REG_4	R/W	GYRO_Z_STR_FT[7:0]								
05	05	IMEM_SRAM_REG_5	R/W	GYRO_Z_STR_FT[15:8]								
06	06	IMEM_SRAM_REG_6	R/W	GYRO_X_CMOS_GAIN_FT[7:0]								
07	07	IMEM_SRAM_REG_7	R/W	-							GYRO_X_CMOS_GAIN_FT[11:8]	
08	08	IMEM_SRAM_REG_8	R/W	GYRO_Y_CMOS_GAIN_FT[7:0]								
09	09	IMEM_SRAM_REG_9	R/W	-							GYRO_Y_CMOS_GAIN_FT[11:8]	
0A	10	IMEM_SRAM_REG_10	R/W	GYRO_Z_CMOS_GAIN_FT[7:0]								
0B	11	IMEM_SRAM_REG_11	R/W	-							GYRO_Z_CMOS_GAIN_FT[11:8]	
38	56	IMEM_SRAM_REG_56	R/W	ST_AVG_TIME[0]	-					ST_GYRO_EN	ST_ACCEL_EN	STC_INIT_EN
39	57	IMEM_SRAM_REG_57	R/W	ST_GYRO_LIMIT			ST_ACCEL_LIMIT			ST_AVG_TIME[2:1]		
40	64	IMEM_SRAM_REG_64	R/W	ST_DEBUG_EN								
44	68	IMEM_SRAM_REG_68	R	ST_STATUS		GZ_ST_PASS	GY_ST_PASS	GX_ST_PASS	AZ_ST_PASS	AY_ST_PASS	AX_ST_PASS	
5C	92	IMEM_SRAM_REG_92	R/W	QUAT_RESET_EN								
60	96	IMEM_SRAM_REG_96	R/W	STC_GAIN_GX[7:0]								
61	97	IMEM_SRAM_REG_97	R/W	STC_GAIN_GX[15:8]								
62	98	IMEM_SRAM_REG_98	R/W	STC_GAIN_GX[23:16]								
63	99	IMEM_SRAM_REG_99	R/W	STC_GAIN_GX[31:24]								
64	100	IMEM_SRAM_REG_100	R/W	STC_GAIN_GY[7:0]								
65	101	IMEM_SRAM_REG_101	R/W	STC_GAIN_GY[15:8]								
66	102	IMEM_SRAM_REG_102	R/W	STC_GAIN_GY[23:16]								
67	103	IMEM_SRAM_REG_103	R/W	STC_GAIN_GY[31:24]								
68	104	IMEM_SRAM_REG_104	R/W	STC_GAIN_GZ[7:0]								
69	105	IMEM_SRAM_REG_105	R/W	STC_GAIN_GZ[15:8]								
6A	106	IMEM_SRAM_REG_106	R/W	STC_GAIN_GZ[23:16]								
6B	107	IMEM_SRAM_REG_107	R/W	STC_GAIN_GZ[31:24]								
88	136	IMEM_SRAM_REG_136	R/W	FF_DURATION_BUF1[7:0]								
89	137	IMEM_SRAM_REG_137	R/W	FF_DURATION_BUF1[15:8]								
8A	138	IMEM_SRAM_REG_138	R/W	FF_DURATION_BUF2[7:0]								
8B	139	IMEM_SRAM_REG_139	R/W	FF_DURATION_BUF2[15:8]								
8D	141	IMEM_SRAM_REG_141	R/W	TAP_NUM								
8E	142	IMEM_SRAM_REG_142	R/W	TAP_AXIS								
8F	143	IMEM_SRAM_REG_143	R/W	TAP_DIR								
90	144	IMEM_SRAM_REG_144	R/W	DOUBLE_TAP_TIMING								
92	146	IMEM_SRAM_REG_146	R/W	TILT_RESET_EN								
9A	154	IMEM_SRAM_REG_154	R/W	PED_STEP_CNT_BUF1[7:0]								
9B	155	IMEM_SRAM_REG_155	R/W	PED_STEP_CNT_BUF1[15:8]								
9C	156	IMEM_SRAM_REG_156	R/W	PED_STEP_CNT_BUF2[7:0]								
9D	157	IMEM_SRAM_REG_157	R/W	PED_STEP_CNT_BUF2[15:8]								
9F	159	IMEM_SRAM_REG_159	R/W	PED_STEP_CADENCE								
A0	160	IMEM_SRAM_REG_160	R/W	POWER_ACTIVITY_CLASS								
B6	182	IMEM_SRAM_REG_182	R/W	ES_RAM_IMAGE_EN								
B9	185	IMEM_SRAM_REG_185	R/W	ESO_COMPASS_EN								
BA	186	IMEM_SRAM_REG_186	R/W	ES_POWER_MODE								
C4	196	IMEM_SRAM_REG_196	R/W	POWER_SAVE_TIME[7:0]								
C5	197	IMEM_SRAM_REG_197	R/W	POWER_SAVE_TIME[15:8]								

Addr (Hex)	Addr (Dec.)	Register Name	Serial I/F	Bit7	Bit6	Bit5	Bit4	Bit3	Bit2	Bit1	Bit0
C6	198	IMEM_SRAM_REG_198	R/W								POWER_SAVE_TIME[23:16]
C7	199	IMEM_SRAM_REG_199	R/W								POWER_SAVE_TIME[31:24]
120	288	IMEM_SRAM_REG_288	R/W								FF_MIN_DURATION[7:0]
121	289	IMEM_SRAM_REG_289	R/W								FF_MIN_DURATION[15:8]
122	290	IMEM_SRAM_REG_290	R/W								FF_MIN_DURATION[23:16]
123	291	IMEM_SRAM_REG_291	R/W								FF_MIN_DURATION[31:24]
124	292	IMEM_SRAM_REG_292	R/W								FF_MAX_DURATION[7:0]
125	293	IMEM_SRAM_REG_293	R/W								FF_MAX_DURATION[15:8]
126	294	IMEM_SRAM_REG_294	R/W								FF_MAX_DURATION[23:16]
127	295	IMEM_SRAM_REG_295	R/W								FF_MAX_DURATION[31:24]
128	296	IMEM_SRAM_REG_296	R/W								FF_DEBOUNCE_DURATION[7:0]
129	297	IMEM_SRAM_REG_297	R/W								FF_DEBOUNCE_DURATION[15:8]
12A	298	IMEM_SRAM_REG_298	R/W								FF_DEBOUNCE_DURATION[23:16]
12B	299	IMEM_SRAM_REG_299	R/W								FF_DEBOUNCE_DURATION[31:24]
130	304	IMEM_SRAM_REG_304	R/W								HIGHG_PEAK_TH[7:0]
131	305	IMEM_SRAM_REG_305	R/W								HIGHG_PEAK_TH[15:8]
132	306	IMEM_SRAM_REG_306	R/W								HIGHG_PEAK_TH_HYST[7:0]
133	307	IMEM_SRAM_REG_307	R/W								HIGHG_PEAK_TH_HYST[15:8]
134	308	IMEM_SRAM_REG_308	R/W								HIGHG_TIME_TH[7:0]
135	309	IMEM_SRAM_REG_309	R/W								HIGHG_TIME_TH[15:8]
13C	316	IMEM_SRAM_REG_316	R/W								LOWG_PEAK_TH[7:0]
13D	317	IMEM_SRAM_REG_317	R/W								LOWG_PEAK_TH[15:8]
13E	318	IMEM_SRAM_REG_318	R/W								LOWG_PEAK_TH_HYST[7:0]
13F	319	IMEM_SRAM_REG_319	R/W								LOWG_PEAK_TH_HYST[15:8]
140	320	IMEM_SRAM_REG_320	R/W								LOWG_TIME_TH[7:0]
141	321	IMEM_SRAM_REG_321	R/W								LOWG_TIME_TH[15:8]
188	392	IMEM_SRAM_REG_392	R/W								TILT_WAIT_TIME[7:0]
189	393	IMEM_SRAM_REG_393	R/W								TILT_WAIT_TIME[15:8]
190	400	IMEM_SRAM_REG_400	R/W								TAP_TMAX[7:0]
191	401	IMEM_SRAM_REG_401	R/W								TAP_TMAX[15:8]
192	402	IMEM_SRAM_REG_402	R/W								TAP_TMIN
193	403	IMEM_SRAM_REG_403	R/W								TAP_MIN_JERK
194	404	IMEM_SRAM_REG_404	R/W								TAP_SMUDGE_REJECT_THR
195	405	IMEM_SRAM_REG_405	R/W								TAP_MAX_PEAK_TOL
196	406	IMEM_SRAM_REG_406	R/W								TAP_TAVG
21C	543	IMEM_SRAM_REG_540	R/W								R2W_SLEEP_TIME_OUT[7:0]
21D	543	IMEM_SRAM_REG_541	R/W								R2W_SLEEP_TIME_OUT[15:8]
21E	543	IMEM_SRAM_REG_542	R/W								R2W_SLEEP_TIME_OUT[23:16]
21F	543	IMEM_SRAM_REG_543	R/W								R2W_SLEEP_TIME_OUT[31:24]
220	544	IMEM_SRAM_REG_544	R/W								R2W_SLEEP_GESTURE_DELAY[7:0]
221	545	IMEM_SRAM_REG_545	R/W								R2W_SLEEP_GESTURE_DELAY[15:8]
222	546	IMEM_SRAM_REG_546	R/W								R2W_SLEEP_GESTURE_DELAY[23:16]
223	547	IMEM_SRAM_REG_547	R/W								R2W_SLEEP_GESTURE_DELAY[31:24]
224	548	IMEM_SRAM_REG_548	R/W								R2W_MOUNTING_MATRIX[7:0]
225	549	IMEM_SRAM_REG_549	R/W								R2W_MOUNTING_MATRIX[15:8]
226	550	IMEM_SRAM_REG_550	R/W								R2W_MOUNTING_MATRIX[23:16]
227	551	IMEM_SRAM_REG_551	R/W								R2W_MOUNTING_MATRIX[31:24]
22C	556	IMEM_SRAM_REG_556	R/W								R2W_GRAVITY_FILTER_GAIN[7:0]
22D	557	IMEM_SRAM_REG_557	R/W								R2W_GRAVITY_FILTER_GAIN[15:8]
22E	558	IMEM_SRAM_REG_558	R/W								R2W_GRAVITY_FILTER_GAIN[23:16]
22F	559	IMEM_SRAM_REG_559	R/W								R2W_GRAVITY_FILTER_GAIN[31:24]

Addr (Hex)	Addr (Dec.)	Register Name	Serial I/F	Bit7	Bit6	Bit5	Bit4	Bit3	Bit2	Bit1	Bit0
230	560	IMEM_SRAM_REG_560	R/W								R2W_MOTION_THR_ANGLE_COSINE[7:0]
231	561	IMEM_SRAM_REG_561	R/W								R2W_MOTION_THR_ANGLE_COSINE[15:8]
232	562	IMEM_SRAM_REG_562	R/W								R2W_MOTION_THR_ANGLE_COSINE[23:16]
233	563	IMEM_SRAM_REG_563	R/W								R2W_MOTION_THR_ANGLE_COSINE[31:24]
234	564	IMEM_SRAM_REG_564	R/W								R2W_MOTION_THR_TIMER_FAST[7:0]
235	565	IMEM_SRAM_REG_565	R/W								R2W_MOTION_THR_TIMER_FAST[15:8]
236	566	IMEM_SRAM_REG_566	R/W								R2W_MOTION_THR_TIMER_FAST[23:16]
237	567	IMEM_SRAM_REG_567	R/W								R2W_MOTION_THR_TIMER_FAST[31:24]
238	568	IMEM_SRAM_REG_568	R/W								R2W_MOTION_THR_TIMER_SLOW[7:0]
239	569	IMEM_SRAM_REG_569	R/W								R2W_MOTION_THR_TIMER_SLOW[15:8]
23A	570	IMEM_SRAM_REG_570	R/W								R2W_MOTION_THR_TIMER_SLOW[23:16]
23B	571	IMEM_SRAM_REG_571	R/W								R2W_MOTION_THR_TIMER_SLOW[31:24]
23C	572	IMEM_SRAM_REG_572	R/W								R2W_MOTION_PREV_GRAVITY_TIMEOUT[7:0]
23D	573	IMEM_SRAM_REG_573	R/W								R2W_MOTION_PREV_GRAVITY_TIMEOUT[15:8]
23E	574	IMEM_SRAM_REG_574	R/W								R2W_MOTION_PREV_GRAVITY_TIMEOUT[23:16]
23F	575	IMEM_SRAM_REG_575	R/W								R2W_MOTION_PREV_GRAVITY_TIMEOUT[31:24]
240	576	IMEM_SRAM_REG_576	R/W								R2W_LAST_GRAVITY_MOTION_TIMER[7:0]
241	577	IMEM_SRAM_REG_577	R/W								R2W_LAST_GRAVITY_MOTION_TIMER[15:8]
242	578	IMEM_SRAM_REG_578	R/W								R2W_LAST_GRAVITY_MOTION_TIMER[23:16]
243	579	IMEM_SRAM_REG_579	R/W								R2W_LAST_GRAVITY_MOTION_TIMER[31:24]
244	580	IMEM_SRAM_REG_580	R/W								R2W_LAST_GRAVITY_TIMEOUT[7:0]
245	581	IMEM_SRAM_REG_581	R/W								R2W_LAST_GRAVITY_TIMEOUT[15:8]
246	582	IMEM_SRAM_REG_582	R/W								R2W_LAST_GRAVITY_TIMEOUT[23:16]
247	583	IMEM_SRAM_REG_583	R/W								R2W_LAST_GRAVITY_TIMEOUT[31:24]
248	584	IMEM_SRAM_REG_584	R/W								R2W_GESTURE_VALIDITY_TIMEOUT[7:0]
249	585	IMEM_SRAM_REG_585	R/W								R2W_GESTURE_VALIDITY_TIMEOUT[15:8]
24A	586	IMEM_SRAM_REG_586	R/W								R2W_GESTURE_VALIDITY_TIMEOUT[23:16]
24B	587	IMEM_SRAM_REG_587	R/W								R2W_GESTURE_VALIDITY_TIMEOUT[31:24]
3DC	988	IMEM_SRAM_REG_988	R/W								PED_STEP_CNT_TH[7:0]
3DD	989	IMEM_SRAM_REG_989	R/W								PED_STEP_CNT_TH[15:8]
3DE	990	IMEM_SRAM_REG_990	R/W								PED_STEP_DET_TH[7:0]
3DF	991	IMEM_SRAM_REG_991	R/W								PED_STEP_DET_TH[15:8]
3E2	994	IMEM_SRAM_REG_994	R/W								PED_SB_TIMER_TH[7:0]
3E3	995	IMEM_SRAM_REG_995	R/W								PED_SB_TIMER_TH[15:8]
3E8	1000	IMEM_SRAM_REG_1000	R/W								PED_LOW_EN_AMP_TH[7:0]
3E9	1001	IMEM_SRAM_REG_1001	R/W								PED_LOW_EN_AMP_TH[15:8]
3EA	1002	IMEM_SRAM_REG_1002	R/W								PED_LOW_EN_AMP_TH[23:16]
3EB	1003	IMEM_SRAM_REG_1003	R/W								PED_LOW_EN_AMP_TH[31:24]
3EC	1004	IMEM_SRAM_REG_1004	R/W								PED_SENSITIVITY_MODE
3F0	1008	IMEM_SRAM_REG_1008	R/W								PED_AMP_TH[7:0]
3F1	1009	IMEM_SRAM_REG_1009	R/W								PED_AMP_TH[15:8]
3F2	1010	IMEM_SRAM_REG_1010	R/W								PED_AMP_TH[23:16]
3F3	1011	IMEM_SRAM_REG_1011	R/W								PED_AMP_TH[31:24]
3F8	1016	IMEM_SRAM_REG_1016	R/W								PED_HI_EN_TH[7:0]
3F9	1017	IMEM_SRAM_REG_1017	R/W								PED_HI_EN_TH[15:8]
3FA	1018	IMEM_SRAM_REG_1018	R/W								PED_HI_EN_TH[23:16]
3FB	1019	IMEM_SRAM_REG_1019	R/W								PED_HI_EN_TH[31:24]
412	1042	IMEM_SRAM_REG_1042	R/W								SMD_SENSITIVITY
490 to 4B3	1168 to 1203	IMEM_SRAM_REG_1168 to IMEM_SRAM_REG_1203	R/W								SOFT_IRON_SENSITIVITY_MATRIX[287:0]

16.3 USER BANK IPREG_BAR REGISTER MAP

Addr (Hex)	Addr (Dec.)	Register Name	Serial I/F	Bit7	Bit6	Bit5	Bit4	Bit3	Bit2	Bit1	Bit0	
39	57	IPREG_BAR_REG_57	R/W	-	IO_OPT0	IO_OPT1	-					
3A	58	IPREG_BAR_REG_58	R/W	PADS_AP_SCLK_PUD_TRIM_D2A	PADS_AP_SCLK_PE_TRIM_D2A	-	PADS_AP_CS_PUD_TRIM_D2A	PADS_AP_CS_PE_TRIM_D2A	-		IO_OPT2	
3B	59	IPREG_BAR_REG_59	R/W	PADS_PIN7_PE_TRIM_D2A	-	PADS_AP_SDO_PUD_TRIM_D2A	PADS_AP_SDO_PUD_TRIM_D2A	-	PADS_AP_SDO_PUD_TRIM_D2A	PADS_AP_SDO_PE_TRIM_D2A	-	
3C	60	IPREG_BAR_REG_60	R/W	-	PADS_AUX1_SCLK_PUD_TRIM_D2A	PADS_AUX1_SCLK_PE_TRIM_D2A	PADS_AUX1_SCLK_TP2_FRM_PAD_DISABLER_TRIM_D2A	PADS_AUX1_CS_PUD_TRIM_D2A	PADS_AUX1_CS_PE_TRIM_D2A	-	PADS_PIN7_CS_PUD_TRIM_D2A	
3D	61	IPREG_BAR_REG_61	R/W	PADS_INT1_PUD_TRIM_D2A	PADS_INT1_PE_TRIM_D2A	-	PADS_AUX1_SDO_PUD_TRIM_D2A	PADS_AUX1_SDO_PE_TRIM_D2A	-	PADS_AUX1_SDO_PUD_TRIM_D2A	PADS_AUX1_SDO_PE_TRIM_D2A	
3E	62	IPREG_BAR_REG_62	R/W	-					PADS_INT2_PUD_TRIM_D2A	PADS_INT2_PE_TRIM_D2A	-	

16.4 USER BANK IPREG_TOP1 REGISTER MAP

Addr (Hex)	Addr (Dec.)	Register Name	Serial I/F	Bit7	Bit6	Bit5	Bit4	Bit3	Bit2	Bit1	Bit0	
06	06	I2CM_COMMAND_0	R/W	ENDFLAG_0	CH_SEL_0	R_W_0		BURSTLEN_0				
07	07	I2CM_COMMAND_1	R/W	ENDFLAG_1	CH_SEL_1	R_W_1		BURSTLEN_1				
08	08	I2CM_COMMAND_2	R/W	ENDFLAG_2	CH_SEL_2	R_W_2		BURSTLEN_2				
09	09	I2CM_COMMAND_3	R/W	ENDFLAG_3	CH_SEL_3	R_W_3		BURSTLEN_3				
0E	14	I2CM_DEV_PROFILE0	R/W	RD_ADDRESS_0								
0F	15	I2CM_DEV_PROFILE1	R/W	-	DEV_ID_0							
10	16	I2CM_DEV_PROFILE2	R/W	RD_ADDRESS_1								
11	17	I2CM_DEV_PROFILE3	R/W	-	DEV_ID_1							
16	22	I2CM_CONTROL	RWS	-	I2CM_RESTART_EN	-		I2CM_SPEED	-		I2CM_GO	
18	24	I2CM_STATUS	R	-		I2CM_SDA_ERR	I2CM_SCL_ERR	I2CM_SRST_ERR	I2CM_TIMEOUT_ERR	I2CM_DONE	I2CM_BUSY	
1A	26	I2CM_EXT_DEV_STATUS		-							I2CM_EXT_DEV_STATUS	
1B	27	I2CM_RD_DATA0	RWS	I2CM_RD_DATA0								
1C	28	I2CM_RD_DATA1	RWS	I2CM_RD_DATA1								
1D	29	I2CM_RD_DATA2	RWS	I2CM_RD_DATA2								
1E	30	I2CM_RD_DATA3	RWS	I2CM_RD_DATA3								
1F	31	I2CM_RD_DATA4	RWS	I2CM_RD_DATA4								
20	32	I2CM_RD_DATA5	RWS	I2CM_RD_DATA5								
21	33	I2CM_RD_DATA6	RWS	I2CM_RD_DATA6								
22	34	I2CM_RD_DATA7	RWS	I2CM_RD_DATA7								
23	35	I2CM_RD_DATA8	RWS	I2CM_RD_DATA8								
24	36	I2CM_RD_DATA9	RWS	I2CM_RD_DATA9								
25	37	I2CM_RD_DATA10	RWS	I2CM_RD_DATA10								
26	38	I2CM_RD_DATA11	RWS	I2CM_RD_DATA11								
27	39	I2CM_RD_DATA12	RWS	I2CM_RD_DATA12								
28	40	I2CM_RD_DATA13	RWS	I2CM_RD_DATA13								
29	41	I2CM_RD_DATA14	RWS	I2CM_RD_DATA14								
2A	42	I2CM_RD_DATA15	RWS	I2CM_RD_DATA15								
2B	43	I2CM_RD_DATA16	RWS	I2CM_RD_DATA16								
2C	44	I2CM_RD_DATA17	RWS	I2CM_RD_DATA17								
2D	45	I2CM_RD_DATA18	RWS	I2CM_RD_DATA18								

Addr (Hex)	Addr (Dec.)	Register Name	Serial I/F	Bit7	Bit6	Bit5	Bit4	Bit3	Bit2	Bit1	Bit0		
2E	46	I2CM_RD_DATA19	RWS	I2CM_RD_DATA19									
2F	47	I2CM_RD_DATA20	RWS	I2CM_RD_DATA20									
33	51	I2CM_WR_DATA0	R/W	I2CM_WR_DATA0									
34	52	I2CM_WR_DATA1	R/W	I2CM_WR_DATA1									
35	53	I2CM_WR_DATA2	R/W	I2CM_WR_DATA2									
36	54	I2CM_WR_DATA3	R/W	I2CM_WR_DATA3									
37	55	I2CM_WR_DATA4	R/W	I2CM_WR_DATA4									
38	56	I2CM_WR_DATA5	R/W	I2CM_WR_DATA5									
4B	75	SIFS_IXC_ERROR_STATUS	R/C							AUX1_SIFS_IXC_TIMEOUT_ERR	SIFS_IXC_TIMEOUT_ERR		
4F	79	EDMP_PRGRM_IRQ0_0	R/W	PRGRM_STRT_ADDR_IRQ_0[7:0]									
50	80	EDMP_PRGRM_IRQ0_1	R/W	PRGRM_STRT_ADDR_IRQ_0[15:8]									
51	81	EDMP_PRGRM_IRQ1_0	R/W	PRGRM_STRT_ADDR_IRQ_1[7:0]									
52	82	EDMP_PRGRM_IRQ1_1	R/W	PRGRM_STRT_ADDR_IRQ_1[15:8]									
53	83	EDMP_PRGRM_IRQ2_0	R/W	PRGRM_STRT_ADDR_IRQ_2[7:0]									
54	84	EDMP_PRGRM_IRQ2_1	R/W	PRGRM_STRT_ADDR_IRQ_2[15:8]									
55	85	EDMP_SP_START_ADDR	R/W	EDMP_SP_START_ADDR									
58	88	SMC_CONTROL_0	R/W				ACCEL_LP_CLK_SEL	TEMP_DIS	TMST_FORCE_AUX_FINE_EN	TMST_FSYNC_EN	TMST_EN		
59	89	SMC_CONTROL_1	R/W					SREG_AUX_ACCEL_ONLY_EN					
63	99	STC_CONFIG	R/W				STC_SENSOR_SEL						
67	103	SREG_CTRL	R/W							SREG_DATA_ENDIAN_SEL			
68	104	SIFS_I3C_STC_CFG	R/W					I3C_STC_MODE					
69	105	INT_PULSE_MIN_ON_INTF0	R/W							INT0_TPULSE_DURATION			
6A	106	INT_PULSE_MIN_ON_INTF1	R/W							INT1_TPULSE_DURATION			
6B	107	INT_PULSE_MIN_OFF_INTF0	R/W							INT0_TDEASSERT_DISABLE			
6C	108	INT_PULSE_MIN_OFF_INTF1	R/W							INT1_TDEASSERT_DISABLE			
6E	110	ISR_0_7	R/C	-		INT_STATUS_ON_DEMAND_PIN_0	-	INT_STATUS_EXT_ODR_DRDY_PIN_0	-		INT_STATUS_ACCEL_DRDY_PIN_0		
6F	111	ISR_8_15	R/C	-		INT_STATUS_ON_DEMAND_PIN_1	-	INT_STATUS_EXT_ODR_DRDY_PIN_1	-		INT_STATUS_ACCEL_DRDY_PIN_1		
70	112	ISR_16_23	R/C	-		INT_STATUS_ON_DEMAND_PIN_2	-	INT_STATUS_EXT_ODR_DRDY_PIN_2	-		INT_STATUS_ACCEL_DRDY_PIN_2		
71	113	STATUS_MASK_PIN_0_7	R/W	-		INT_ON_DEMAND_PIN_0_DIS	-	INT_EXT_ODR_DRDY_PIN_0_DIS	-		INT_ACCEL_DRDY_PIN_0_DIS		
72	114	STATUS_MASK_PIN_8_15	R/W	-		INT_ON_DEMAND_PIN_1_DIS	-	INT_EXT_ODR_DRDY_PIN_1_DIS	-		INT_ACCEL_DRDY_PIN_1_DIS		
73	115	STATUS_MASK_PIN_16_23	R/W	-		INT_ON_DEMAND_PIN_2_DIS	-	INT_EXT_ODR_DRDY_PIN_2_DIS	-		INT_ACCEL_DRDY_PIN_2_DIS		
74	116	INT_I2CM_SOURCE	R/W							INT_STATUS_I2CM_SMC_EXT_ODR_EN			
7E	126	ACCEL_WOM_X_THR	R/W	WOM_X_TH									
7F	127	ACCEL_WOM_Y_THR	R/W	WOM_Y_TH									
80	128	ACCEL_WOM_Z_THR	R/W	WOM_Z_TH									
90	144	SELFTEST		-		EN_GZ_ST	EN_GY_ST	EN_GX_ST	EN_AZ_ST	EN_AY_ST	EN_AX_ST		
97	151	IPREG_MISC	R							EDMP_IDLE			
A2	162	SW_PLL1_TRIM	R	SW_PLL1_TRIM									

Addr (Hex)	Addr (Dec.)	Register Name	Serial I/F	Bit7	Bit6	Bit5	Bit4	Bit3	Bit2	Bit1	Bit0	
A7	167	FIFO_SRAM_SLEEP	R/W	-							FIFO_GSLEEP_SHARED_SRAM	

16.5 USER BANK IPREG_SYS1 REGISTER MAP

Addr (Hex)	Addr (Dec.)	Register Name	Serial I/F	Bit7	Bit6	Bit5	Bit4	Bit3	Bit2	Bit1	Bit0	
2A	42	IPREG_SYS1_REG_42	R/W	GYRO_X_OFFUSER[7:0]								
2B	43	IPREG_SYS1_REG_43	R/W	-	GYRO_X_OFFUSER[13:8]							
38	56	IPREG_SYS1_REG_56	R/W	GYRO_Y_OFFUSER[7:0]								
39	57	IPREG_SYS1_REG_57	R/W	-	GYRO_Y_OFFUSER[13:8]							
46	70	IPREG_SYS1_REG_56	R/W	GYRO_Z_OFFUSER[7:0]								
47	71	IPREG_SYS1_REG_57	R/W	-	GYRO_Z_OFFUSER[13:8]							
A6	166	IPREG_SYS1_REG_166	R/W	-	GYRO_SRC_CTRL		-					
AA	170	IPREG_SYS1_REG_170	R/W	-			GYRO_LP_AVG_SEL					-
AC	172	IPREG_SYS1_REG_172	R/W	-							GYRO_UI_LPFBW_SEL	

16.6 USER BANK IPREG_SYS2 REGISTER MAP

Addr (Hex)	Addr (Dec.)	Register Name	Serial I/F	Bit7	Bit6	Bit5	Bit4	Bit3	Bit2	Bit1	Bit0	
18	24	IPREG_SYS2_REG_24	R/W	ACCEL_X_OFFUSER[7:0]								
19	25	IPREG_SYS2_REG_25	R/W	-	ACCEL_X_OFFUSER[13:8]							
20	32	IPREG_SYS2_REG_32	R/W	ACCEL_Y_OFFUSER[7:0]								
21	33	IPREG_SYS2_REG_33	R/W	-	ACCEL_Y_OFFUSER[13:8]							
28	40	IPREG_SYS2_REG_40	R/W	ACCEL_Z_OFFUSER[7:0]								
29	41	IPREG_SYS2_REG_41	R/W	-	ACCEL_Z_OFFUSER[13:8]							
7B	123	IPREG_SYS2_REG_123	R/W	-							ACCEL_SRC_CTRL	
81	129	IPREG_SYS2_REG_129	R/W	-			ACCEL_LP_AVG_SEL					
83	131	IPREG_SYS2_REG_131	R/W	-							ACCEL_UI_LPFBW_SEL	

Detailed register descriptions are provided in the sections that follow.

Register fields marked as Reserved must not be modified by the user. The Reset Value of the register can be used to determine the default value of reserved register fields, and unless otherwise noted this default value must be maintained even if the values of other register fields are modified by the user.

In the sections that follow, some register fields are described as “can be changed on-the-fly.” These are the only register fields that can be changed on-the-fly even if sensor is on. Register fields not described as such must not be changed on-the-fly if sensor is on.

17 USER BANK 0 REGISTER MAP – DESCRIPTIONS

Please refer to the procedure in Section 14 for configuring device data endianness before using the register map.

17.1 ACCEL_DATA_X1_UI

Name: ACCEL_DATA_X1_UI Address: 00 (00h) Serial IF: SYNCR Reset value: 0x00 Clock Domain: SCLK		
BIT	NAME	FUNCTION
7:0	ACCEL_DATA_X_UI[15:8]	Upper byte of Accel X-axis data for UI path

17.2 ACCEL_DATA_X0_UI

Name: ACCEL_DATA_X0_UI Address: 01 (01h) Serial IF: SYNCR Reset value: 0x00 Clock Domain: SCLK		
BIT	NAME	FUNCTION
7:0	ACCEL_DATA_X_UI[7:0]	Lower byte of Accel X-axis data for UI path

17.3 ACCEL_DATA_Y1_UI

Name: ACCEL_DATA_Y1_UI Address: 02 (02h) Serial IF: SYNCR Reset value: 0x00 Clock Domain: SCLK		
BIT	NAME	FUNCTION
7:0	ACCEL_DATA_Y_UI[15:8]	Upper byte of Accel Y-axis data for UI path

17.4 ACCEL_DATA_Y0_UI

Name: ACCEL_DATA_Y0_UI Address: 03 (03h) Serial IF: SYNCR Reset value: 0x00 Clock Domain: SCLK		
BIT	NAME	FUNCTION
7:0	ACCEL_DATA_Y_UI[7:0]	Lower byte of Accel Y-axis data for UI path

17.5 ACCEL_DATA_Z1_UI

Name: ACCEL_DATA_Z1_UI Address: 04 (04h) Serial IF: SYNCR Reset value: 0x00 Clock Domain: SCLK		
BIT	NAME	FUNCTION
7:0	ACCEL_DATA_Z_UI[15:8]	Upper byte of Accel Z-axis data for UI path

17.6 ACCEL_DATA_Z0_UI

Name: ACCEL_DATA_Z0_UI
 Address: 05 (05h)
 Serial IF: SYNCR
 Reset value: 0x00
 Clock Domain: SCLK

BIT	NAME	FUNCTION
7:0	ACCEL_DATA_Z_UI[7:0]	Lower byte of Accel Z-axis data for UI path

17.7 GYRO_DATA_X1_UI

Name: GYRO_DATA_X1_UI
 Address: 06 (06h)
 Serial IF: SYNCR
 Reset value: 0x00
 Clock Domain: SCLK

BIT	NAME	FUNCTION
7:0	GYRO_DATA_X_UI[15:8]	Upper byte of Gyro X-axis data for UI path

17.8 GYRO_DATA_X0_UI

Name: GYRO_DATA_X0_UI
 Address: 07 (07h)
 Serial IF: SYNCR
 Reset value: 0x00
 Clock Domain: SCLK

BIT	NAME	FUNCTION
7:0	GYRO_DATA_X_UI[7:0]	Lower byte of Gyro X-axis data for UI path

17.9 GYRO_DATA_Y1_UI

Name: GYRO_DATA_Y1_UI
 Address: 08 (08h)
 Serial IF: SYNCR
 Reset value: 0x00
 Clock Domain: SCLK

BIT	NAME	FUNCTION
7:0	GYRO_DATA_Y_UI[15:8]	Upper byte of Gyro Y-axis data for UI path

17.10 GYRO_DATA_Y0_UI

Name: GYRO_DATA_Y0_UI
 Address: 09 (09h)
 Serial IF: SYNCR
 Reset value: 0x00
 Clock Domain: SCLK

BIT	NAME	FUNCTION
7:0	GYRO_DATA_Y_UI[7:0]	Lower byte of Gyro Y-axis data for UI path

17.11 GYRO_DATA_Z1_UI

Name: GYRO_DATA_Z1_UI		
Address: 10 (0Ah)		
Serial IF: SYNCR		
Reset value: 0x00		
Clock Domain: SCLK		
BIT	NAME	FUNCTION
7:0	GYRO_DATA_Z_UI[15:8]	Upper byte of Gyro Z-axis data for UI path

17.12 GYRO_DATA_Z0_UI

Name: GYRO_DATA_Z0_UI		
Address: 11 (0Bh)		
Serial IF: SYNCR		
Reset value: 0x00		
Clock Domain: SCLK		
BIT	NAME	FUNCTION
7:0	GYRO_DATA_Z_UI[7:0]	Lower byte of Gyro Z-axis data for UI path

17.13 TEMP_DATA1_UI

Name: TEMP_DATA1_UI		
Address: 12 (0Ch)		
Serial IF: SYNCR		
Reset value: 0x00		
Clock Domain: SCLK		
BIT	NAME	FUNCTION
7:0	TEMP_DATA_UI[15:8]	Upper byte of temperature data for UI path

17.14 TEMP_DATA0_UI

Name: TEMP_DATA0_UI		
Address: 13 (0Dh)		
Serial IF: SYNCR		
Reset value: 0x00		
Clock Domain: SCLK		
BIT	NAME	FUNCTION
7:0	TEMP_DATA_UI[7:0]	Lower byte of temperature data for UI path

Temperature data value from the sensor data registers can be converted to degrees centigrade by using the following formula:

$$\text{Temperature in Degrees Centigrade} = (\text{TEMP_DATA} / 128) + 25$$

Temperature data stored in FIFO is an 8-bit quantity, FIFO_TEMP_DATA. It can be converted to degrees centigrade by using the following formula:

$$\text{Temperature in Degrees Centigrade} = (\text{FIFO_TEMP_DATA} / 2) + 25$$

17.15 TMST_FSYNCH

Name: TMST_FSYNCH Address: 14 (0Eh) Serial IF: SYNCR Reset value: 0x00 Clock Domain: SCLK		
BIT	NAME	FUNCTION
7:0	TMST_FSYNCH_DATA_UI[15:8]	Stores the upper byte of the time delta from the rising edge of FSYNC to the latest ODR until the UI Interface reads the FSYNC tag in the status register

17.16 TMST_FSYNCL

Name: TMST_FSYNCL Address: 15 (0Fh) Serial IF: SYNCR Reset value: 0x00 Clock Domain: SCLK		
BIT	NAME	FUNCTION
7:0	TMST_FSYNCH_DATA_UI[7:0]	Stores the lower byte of the time delta from the rising edge of FSYNC to the latest ODR until the UI Interface reads the FSYNC tag in the status register

17.17 PWR_MGMT0

Name: PWR_MGMT0 Address: 16 (10h) Serial IF: R/W Reset value: 0x00 Clock Domain: MCLK		
BIT	NAME	FUNCTION
7:4	-	Reserved
3:2	GYRO_MODE	00: Turns gyroscope off 01: Places gyroscope in Standby Mode 10: Places gyroscope in Low Power (LP) Mode 11: Places gyroscope in Low Noise (LN) Mode Can be changed on-the-fly.
1:0	ACCEL_MODE	00: Turns accelerometer off 01: Turns accelerometer off 10: Places accelerometer in Low Power (LP) Mode 11: Places accelerometer in Low Noise (LN) Mode Can be changed on-the-fly.

17.18 FIFO_COUNT_0

Name: FIFO_COUNT_0
 Address: 18 (12h)
 Serial IF: R
 Reset value: 0x00
 Clock Domain: SCLK

BIT	NAME	FUNCTION
7:0	FIFO_DATA_CNT[15:8]	High Bits, count indicates the number of packets available in FIFO.

17.19 FIFO_COUNT_1

Name: FIFO_COUNT_1
 Address: 19 (13h)
 Serial IF: R
 Reset value: 0x00
 Clock Domain: SCLK

BIT	NAME	FUNCTION
7:0	FIFO_DATA_CNT[7:0]	Low Bits, count indicates the number of packets available in FIFO.

17.20 FIFO_DATA

Name: FIFO_DATA
 Address: 20 (14h)
 Serial IF: R
 Reset value: 0x7F
 Clock Domain: SCLK

BIT	NAME	FUNCTION
7:0	FIFO_DATA	FIFO data port

17.21 INT1_CONFIG0

Name: INT1_CONFIG0 Address: 22 (16h) Serial IF: R/W Reset value: 0x80 Clock Domain: MCLK		
BIT	NAME	FUNCTION
7	INT1_STATUS_EN_RESET_DONE	Enable interrupt status bit to flag the occurrence of Reset Done event on INT1 0: Disable interrupt. 1: Enable interrupt. Setting can be changed by UI interface.
6	INT1_STATUS_EN_AUX1_AGC_RDY	Enable interrupt status bit to flag the occurrence of AUX1 AGC Ready event on INT1 0: Disable interrupt. 1: Enable interrupt. Setting can be changed by UI interface.
5	INT1_STATUS_EN_AP_AGC_RDY	Enable interrupt status bit to flag the occurrence of UI AGC Ready event on INT1 0: Disable interrupt. 1: Enable interrupt. Setting can be changed by UI interface.
4	INT1_STATUS_EN_AP_FSYNC	Enable interrupt status bit to flag the occurrence of UI FSYNC event on INT1 0: Disable interrupt. 1: Enable interrupt. Setting can be changed by UI interface.
3	INT1_STATUS_EN_AUX1_DRDY	Enable interrupt status bit to flag the occurrence of AUX1 Data Ready event on INT1 0: Disable interrupt. 1: Enable interrupt. Setting can be changed by UI interface.
2	INT1_STATUS_EN_DRDY	Enable interrupt status bit to flag the occurrence of UI Data Ready event on INT1 0: Disable interrupt. 1: Enable interrupt. Setting can be changed by UI interface.
1	INT1_STATUS_EN_FIFO_THRESHOLD	Enable interrupt status bit to flag the occurrence of FIFO count \geq FIFO threshold event on INT1

		<p>0: Disable interrupt. 1: Enable interrupt.</p> <p>Setting can be changed by UI interface.</p>
0	INT1_STATUS_EN_FIFO_FULL	<p>Enable interrupt status bit to flag the occurrence of FIFO full event on INT1</p> <p>0: Disable interrupt. 1: Enable interrupt.</p> <p>Setting can be changed by UI interface.</p>

17.22 INT1_CONFIG1

Name: INT1_CONFIG1 Address: 23 (17h) Serial IF: R/W Reset value: 0x00 Clock Domain: MCLK		
BIT	NAME	FUNCTION
7	-	Reserved
6	INT1_STATUS_EN_APEX_EVENT	Enable interrupt status bit to flag the occurrence of APEX event on INT1 0: Disable interrupt. 1: Enable interrupt. Setting can be changed by UI interface.
5	INT1_STATUS_EN_I2CM_DONE	Enable interrupt status bit to flag the completion of I ² C master event on INT1 0: Disable interrupt. 1: Enable interrupt. Setting can be changed by UI interface.
4	INT1_STATUS_EN_I3C_PROTOCOL_ERR	Enable interrupt status bit to flag the occurrence of I3C Protocol Error event on INT1 0: Disable interrupt. 1: Enable interrupt. Setting can be changed by UI interface.
3	INT1_STATUS_EN_WOM_Z	Enable interrupt status bit to flag the occurrence of WOM on Z-axis event on INT1 0: Disable interrupt. 1: Enable interrupt. Setting can be changed by UI interface.
2	INT1_STATUS_EN_WOM_Y	Enable interrupt status bit to flag the occurrence of WOM on Y-axis event on INT1 0: Disable interrupt. 1: Enable interrupt. Setting can be changed by UI interface.
1	INT1_STATUS_EN_WOM_X	Enable interrupt status bit to flag the occurrence of WOM on X-axis event on INT1 0: Disable interrupt. 1: Enable interrupt. Setting can be changed by UI interface.
0	INT1_STATUS_EN_PLL_RDY	Enable interrupt status bit to flag the occurrence of PLL Ready event on INT1 0: Disable interrupt.

		1: Enable interrupt. Setting can be changed by UI interface.
--	--	---

17.23 INT1_CONFIG2

Name: INT1_CONFIG2 Address: 24 (18h) Serial IF: R/W Reset value: 0x04 Clock Domain: MCLK		
BIT	NAME	FUNCTION
7:3	-	Reserved
2	INT1_DRIVE	Sets INT1 to open-drain or push-pull 0: Push-pull 1: Open-drain
1	INT1_MODE	INT1 interrupt mode 0: Pulse mode 1: Latch mode Setting can be changed only when all interrupts of the corresponding serial interface are disabled
0	INT1_POLARITY	INT1 interrupt polarity 0: Active low 1: Active high Setting can be changed only when all interrupts of the corresponding serial interface are disabled

17.24 INT1_STATUS0

Name: INT1_STATUS0 Address: 25 (19h) Serial IF: R/C Reset value: 0x00 Clock Domain: MCLK		
BIT	NAME	FUNCTION
7	INT1_STATUS_RESET_DONE	Flags the occurrence of Reset Done event on INT1 0: Interrupt did not occur 1: Interrupt occurred
6	INT1_STATUS_AUX1_AGC_RDY	Flags the occurrence of AUX1 AGC Ready event on INT1 0: Interrupt did not occur 1: Interrupt occurred
5	INT1_STATUS_AP_AGC_RDY	Flags the occurrence of UI AGC Ready event on INT1 0: Interrupt did not occur 1: Interrupt occurred
4	INT1_STATUS_AP_FSYNC	Flags the occurrence of UI FSYNC event on INT1 0: Interrupt did not occur 1: Interrupt occurred
3	INT1_STATUS_AUX1_DRDY	Flags the occurrence of AUX1 Data Ready event on INT1 0: Interrupt did not occur 1: Interrupt occurred
2	INT1_STATUS_DRDY	Flags the occurrence of UI Data Ready event on INT1 0: Interrupt did not occur 1: Interrupt occurred
1	INT1_STATUS_FIFO_THS	Flags the occurrence of FIFO count \geq FIFO threshold event on INT1 0: Interrupt did not occur 1: Interrupt occurred
0	INT1_STATUS_FIFO_FULL	Flags the occurrence of FIFO full event on INT1 0: Interrupt did not occur 1: Interrupt occurred

17.25 INT1_STATUS1

Name: INT1_STATUS1 Address: 26 (1Ah) Serial IF: R/C Reset value: 0x00 Clock Domain: MCLK		
BIT	NAME	FUNCTION
7	-	Reserved
6	INT1_STATUS_APEX_EVENT	Flags the occurrence of APEX event on INT1 0: Interrupt did not occur 1: Interrupt occurred
5	INT1_STATUS_I2CM_DONE	Flags the occurrence of I ² C Master Done event on INT1 0: Interrupt did not occur 1: Interrupt occurred
4	INT1_STATUS_I3C_PROTOCOL_ERR	Flags the occurrence of I3C SM Protocol Error event on INT1 0: Interrupt did not occur 1: Interrupt occurred
3	INT1_STATUS_WOM_Z	Flags the occurrence of Z-axis WOM event on INT1 0: Interrupt did not occur 1: Interrupt occurred
2	INT1_STATUS_WOM_Y	Flags the occurrence of Y-axis WOM event on INT1 0: Interrupt did not occur 1: Interrupt occurred
1	INT1_STATUS_WOM_X	Flags the occurrence of X-axis WOM event on INT1 0: Interrupt did not occur 1: Interrupt occurred
0	INT1_STATUS_PLL_RDY	Flags the occurrence of PLL Ready event on INT1 0: Interrupt did not occur 1: Interrupt occurred

17.26 ACCEL_CONFIG0

Name: ACCEL_CONFIG0 Address: 27 (1Bh) Serial IF: R/W Reset value: 0x06 Clock Domain: MCLK		
BIT	NAME	FUNCTION
7	-	Reserved
6:4	ACCEL_UI_FS_SEL	Full scale select for accelerometer UI interface output 000: Reserved 001: ±16g 010: ±8g 011: ±4g 100: ±2g 101: Reserved 110: Reserved 111: Reserved Can be changed on-the-fly.
3:0	ACCEL_ODR	Accelerometer ODR selection for UI interface output 0000: Reserved 0001: Reserved 0010: Reserved 0011: 6.4kHz (LN mode) 0100: 3.2kHz (LN mode) 0101: 1.6kHz (LN mode) 0110: 800Hz (LN mode) 0111: 400Hz (LP or LN mode) 1000: 200Hz (LP or LN mode) 1001: 100Hz (LP or LN mode) 1010: 50Hz (LP or LN mode) 1011: 25Hz (LP or LN mode) 1100: 12.5Hz (LP or LN mode) 1101: 6.25Hz (LP mode) 1110: 3.125Hz (LP mode) 1111: 1.5625Hz (LP mode) Can be changed on-the-fly.

17.27 GYRO_CONFIG0

Name: GYRO_CONFIG0 Address: 28 (1Ch) Serial IF: R/W Reset value: 0x06 Clock Domain: MCLK		
BIT	NAME	FUNCTION
7:4	GYRO_UI_FS_SEL	Full scale select for gyroscope UI interface output 0000: Reserved 0001: ±2000dps 0010: ±1000dps 0011: ±500dps 0100: ±250dps 0101: ±125dps 0110: ±62.5dps 0111: ±31.25dps 1000: ±15.625dps Rest of the settings are reserved Can be changed on-the-fly.
3:0	GYRO_ODR	Gyroscope ODR selection for UI interface output 0000: Reserved 0001: Reserved 0010: Reserved 0011: 6.4kHz (LN mode) 0100: 3.2kHz (LN mode) 0101: 1.6kHz (LN mode) 0110: 800Hz (LN mode) 0111: 400Hz (LP or LN mode) 1000: 200Hz (LP or LN mode) 1001: 100Hz (LP or LN mode) 1010: 50Hz (LP or LN mode) 1011: 25Hz (LP or LN mode) 1100: 12.5Hz (LP or LN mode) 1101: 6.25Hz (LP mode) 1110: 3.125Hz (LP mode) 1111: 1.5625Hz (LP mode) Can be changed on-the-fly.

17.28 FIFO_CONFIG0

Name: FIFO_CONFIG0 Address: 29 (1Dh) Serial IF: R/W Reset value: 0x00 Clock Domain: MCLK		
BIT	NAME	FUNCTION
7:6	FIFO_MODE	Set the FIFO operation mode. 00: Bypass (disabled) 01: Stream mode - Frames are overwritten when the FIFO full condition is reached. Supported only for 8, 16, 20 bytes frame size. When this mode is selected for 32 or 64 bytes frame sizes, FIFO remains in Bypass mode. 10: Stop-on-full mode - Frames are not stored in FIFO once the FIFO full condition is reached. 11: Reserved Can be changed on-the-fly.
5:0	FIFO_DEPTH	Set the FIFO depth in bytes. 000111: Sets FIFO depth to 2K bytes (recommended setting) 011111: Sets FIFO depth to 8K bytes (valid when all APEX features are disabled) Others: Reserved Can be changed when FIFO is disabled (Bypass mode).

17.29 FIFO_CONFIG1_0

Name: FIFO_CONFIG1_0 Address: 30 (1Eh) Serial IF: R/W Reset value: 0x00 Clock Domain: MCLK		
BIT	NAME	FUNCTION
7:0	FIFO_WM_TH[7:0]	Lower bits of FIFO watermark threshold. When set to 0, the watermark is disabled. When writing new threshold value, user must first write threshold LSByte (bits [7:0]), then MSByte (bits [15:8]). New threshold register value will take effect only when MSByte is written. Can be changed on-the-fly.

17.30 FIFO_CONFIG1_1

Name: FIFO_CONFIG1_1 Address: 31 (1Fh) Serial IF: R/W Reset value: 0x00 Clock Domain: MCLK		
BIT	NAME	FUNCTION
7:0	FIFO_WM_TH[15:8]	Upper bits of FIFO watermark threshold. When set to 0, the watermark is disabled. When writing new threshold value, user must first write threshold LSByte (bits [7:0]), then MSByte (bits [15:8]). New threshold register value will take effect only when MSByte is written. Can be changed on-the-fly.

17.31 FIFO_CONFIG2

Name: FIFO_CONFIG2 Address: 32 (20h) Serial IF: R/W Reset value: 0x20 Clock Domain: MCLK		
BIT	NAME	FUNCTION
7	FIFO_FLUSH	FIFO flush command. When set high the FIFO is flushed, meaning the pointers and control logic is reset. Configuration registers are not reset. Can be changed on-the-fly.
6:4	-	Reserved
3	FIFO_WR_WM_GT_TH	Set write watermark interrupt generating condition: 0: Write watermark interrupt generated when FIFO data count is equal to the FIFO watermark threshold 1: Write watermark interrupt generated when FIFO data count is greater than or equal to FIFO watermark threshold Can be changed when FIFO is disabled (Bypass mode).
2:0	-	Reserved

17.32 FIFO_CONFIG3

Name: FIFO_CONFIG3 Address: 33 (21h) Serial IF: R/W Reset value: 0x00 Clock Domain: MCLK		
BIT	NAME	FUNCTION
7:6	-	Reserved
5	FIFO_ES1_EN	Enable External Sensor 1 data insertion into FIFO frame
4	FIFO_ES0_EN	Enable External Sensor 0 data insertion into FIFO frame
3	FIFO_HIRES_EN	Enable high resolution accel and gyro data insertion into FIFO frame
2	FIFO_GYRO_EN	Enable gyro data insertion into FIFO frame
1	FIFO_ACCEL_EN	Enable accel data insertion into FIFO frame
0	FIFO_IF_EN	<p>Enable Sensor Registers write interface to FIFO. This interface should be enabled when the FIFO is also enabled (i.e., not in bypass mode). A standard enable sequence is:</p> <ol style="list-style-type: none"> 1) Enable FIFO. 2) Enable Sensor Registers to FIFO interface. <p>The opposite sequence should be used for the disable.</p> <p>To prevent power drain, FIFO_IF_EN should be set to 0 if FIFO is in bypass mode.</p> <p>Can be changed on-the-fly.</p>

17.33 FIFO_CONFIG4

Name: FIFO_CONFIG4 Address: 34 (22h) Serial IF: R/W Reset value: 0x00 Clock Domain: MCLK		
BIT	NAME	FUNCTION
7:6	-	Reserved
5:3	FIFO_COMP_NC_FLOW_CFG	Configures the compression algorithm to write non-compressed packets to FIFO at a certain rate 000: Non-compressed packet flow is disabled 001: Non-compressed packet every 8 frames 010: Non-compressed packet every 16 frames 011: Non-compressed packet every 32 frames 100: Non-compressed packet every 64 frames 101: Non-compressed packet every 128 frames Others: Reserved
2	FIFO_COMP_EN	0: FIFO compression disabled 1: FIFO compression enabled
1	FIFO_TMST_FSYNC_EN	Enable the insertion of the Timestamp or FSYNC data into FIFO frame 0: No Timestamp/FSYNC data inserted into FIFO frame (timestamp fields are 0x0000). FSYNC_TAG_EN bit in FIFO header is 0. 1: Timestamp/FSYNC data inserted into FIFO frame. FSYNC_TAG_EN bit in FIFO header is set on an FSYNC trigger event.
0	FIFO_ES0_6B_9B	Select number of valid bytes provided by External Sensor 0 0: 6 bytes 1: 9 bytes

17.34 TMST_WOM_CONFIG

Name: TMST_WOM_CONFIG Address: 35 (23h) Serial IF: R/W Reset value: 0x00 Clock Domain: MCLK		
BIT	NAME	FUNCTION
7	-	Reserved
6	TMST_DELTA_EN	Time Stamp Delta Enable 0: Time stamp field does not contain the measurement of time since the last occurrence of trigger event 1: Time stamp field contains the measurement of time since the last occurrence of trigger event
5	TMST_RESOL	Time Stamp Resolution 0: 1 μ s 1: 16 μ s
4	WOM_EN	Wake on Motion Enable 0: Wake on Motion not enabled 1: Wake on Motion enabled
3	WOM_MODE	Wake on Motion Mode 0: Initial sample is stored. Future samples are compared to initial sample 1: Compare current sample to previous sample
2	WOM_INT_MODE	Wake on Motion Interrupt 0: Off 1: On
1:0	WOM_INT_DUR	Wake on Motion Interrupt Duration 00: Wake on Motion interrupt asserted at first over-threshold event 01: Wake on Motion interrupt asserted at second over-threshold event 10: Wake on Motion interrupt asserted at third over-threshold event 11: Wake on Motion interrupt asserted at fourth over-threshold event

17.35 FSYNC_CONFIG0

Name: FSYNC_CONFIG0 Address: 36 (24h) Serial IF: R/W Reset value: 0x00 Clock Domain: MCLK		
BIT	NAME	FUNCTION
7:4	-	Reserved
3	AP_FSYNC_FLAG_CLEAR_SEL	Select the AP/UI FSYNC flag clear policy. 0: The FSYNC flag is cleared when UI/AP sensor register is updated. 1: The FSYNC flag is cleared when UI/AP serial interface reads the sensor register LSB of FSYNC tagged axis.
2:0	AP_FSYNC_SEL	Select the AP/UI sensor that will carry the FSYNC tagging. 0: FSYNC tagging is disabled 1: Tag FSYNC flag to TEMP_DATA_UI LSB 2: Tag FSYNC flag to GYRO_DATA_X_UI LSB 3: Tag FSYNC flag to GYRO_DATA_Y_UI LSB 4: Tag FSYNC flag to GYRO_DATA_Z_UI LSB 5: Tag FSYNC flag to ACCEL_DATA_X_UI LSB 6: Tag FSYNC flag to ACCEL_DATA_Y_UI LSB 7: Tag FSYNC flag to ACCEL_DATA_Z_UI LSB

17.36 DMP_EXT_SEN_ODR_CFG

Name: DMP_EXT_SEN_ODR_CFG Address: 39 (27h) Serial IF: R/W Reset value: 0x01 Clock Domain: MCLK		
BIT	NAME	FUNCTION
7	-	Reserved
6	EXT_SENSOR_EN	0: Disables generation of ODR event for external sensor operation per the setting of EXT_ODR. 1: Enables generation of ODR event for external sensor operation per the setting of EXT_ODR.
5:3	EXT_ODR	I ² C master external sensor ODR 000: 3.125Hz 001: 6.25Hz 010: 12.5Hz 011: 25Hz 100: 50Hz 101: 100Hz 110: 200Hz 111: 400Hz
2:0	APEX_ODR	DMP Output Data Rate. APEX_ODR should be smaller than or equal to both ACCEL_ODR and GYRO_ODR. All rates shown below except 800Hz can be set if Accel UI/AP in in LP mode. Accel UI/AP must be in LN mode to set 800Hz. 000: 25Hz 001: 50Hz 010: 100Hz 011: 200Hz 100: 400Hz 101: 800Hz 110: Reserved 111: Reserved

17.37 ODR_DECIMATE_CONFIG

Name: ODR_DECIMATE_CONFIG Address: 40 (28h) Serial IF: R/W Reset value: 0x00 Clock Domain: MCLK		
BIT	NAME	FUNCTION
7:4	GYRO_FIFO_ODR_DEC	Decimation factor for Gyroscope FIFO data: 0000: 1 (same are input ODR) 0001: 2 0010: 4 0011: 8 0100: 16 0101: 32 0110: 64 0111: 128 1000: 256 1001: 512 1010: 1024 1011: 2048 1100: 4096 1101: Reserved 1110: Reserved 1111: Reserved
3:0	ACCEL_FIFO_ODR_DEC	Decimation factor for Accelerometer FIFO data: 0000: 1 (same are input ODR) 0001: 2 0010: 4 0011: 8 0100: 16 0101: 32 0110: 64 0111: 128 1000: 256 1001: 512 1010: 1024 1011: 2048 1100: 4096 1101: Reserved 1110: Reserved 1111: Reserved

17.38 EDMP_APEX_EN0

Name: EDMP_APEX_EN0		
Address: 41 (29h)		
Serial IF: R/W		
Reset value: 0x00		
Clock Domain: MCLK		
BIT	NAME	FUNCTION
7	SMD_EN	Set 1 to enable SMD algorithm
6	R2W_EN	Set 1 to enable Raise to Wake algorithm
5	FF_EN	Set 1 to enable Freefall algorithm
4	PEDO_EN	Set 1 to enable Pedometer algorithm
3	TILT_EN	Set 1 to enable Tilt algorithm
2:1	-	Reserved
0	TAP_EN	Set 1 to enable Tap algorithm

17.39 EDMP_APEX_EN1

Name: EDMP_APEX_EN1		
Address: 42 (2Ah)		
Serial IF: R/W		
Reset value: 0x00		
Clock Domain: MCLK		
BIT	NAME	FUNCTION
7	-	Reserved
6	EDMP_ENABLE	Set 1 to enable eDMP
5	FEATURE3_EN	Set 1 to enable eDMP to run algorithms from RAM image
4:3	-	Reserved
2	POWER_SAVE_EN	Set 1 to enable power save mode
1	INIT_EN	This bit is set by the host to indicate: eDMP executes only the segment of code that initialize constants used by algorithms.
0	SOFT_HARD_IRON_CORR_EN	Set 1 to enable soft iron hard iron correction

17.40 APEX_BUFFER_MGMT

Name: APEX_BUFFER_MGMT Address: 43 (2Bh) Serial IF: R/W (bits 5:4 are R only) Reset value: 0x00 Clock Domain: MCLK		
BIT	NAME	FUNCTION
7:6	FF_DURATION_HOST_RPTR	LSB indicates SRAM address for host to read; MSB indicates size 2 buffer wrap around 00: Host reads buffer 0 01: Host reads buffer 1 10: Host reads buffer 0 11: Host reads buffer 1
5:4	FF_DURATION_EDMP_WPTR	Read only register field: LSB indicates SRAM address for eDMP to write; MSB indicates size 2 buffer wrap around 00: eDMP writes to buffer 0 01: eDMP writes to buffer 1 10: eDMP writes to buffer 0 11: eDMP writes to buffer 1
3:2	STEP_COUNT_HOST_RPTR	LSB indicates SRAM address for host to read; MSB indicates size 2 buffer wrap around 00: Host reads buffer 0 01: Host reads buffer 1 10: Host reads buffer 0 11: Host reads buffer 1
1:0	STEP_COUNT_EDMP_WPTR	Read only register field: LSB indicates SRAM address for eDMP to write; MSB indicates size 2 buffer wrap around 00: eDMP writes to buffer 0 01: eDMP writes to buffer 1 10: eDMP writes to buffer 0 11: eDMP writes to buffer 1

17.41 INTF_CONFIG0

Name: INTF_CONFIG0 Address: 44 (2Ch) Serial IF: R/W (bits 1 and 0 are Read only) Reset value: 0x9A Clock Domain: MCLK		
BIT	NAME	FUNCTION
7:2	-	Reserved
1	AP_SPI_34_MODE	Read only register field, shows OTP trim for UI interface SPI in 3-wire or 4-wire mode 0: 3-wire mode 1: 4-wire mode
0	AP_SPI_MODE	Read only register field, shows OTP trim for UI interface SPI mode selection 0: SPI mode 0 or 3 1: SPI mode 1 or 2

17.42 INTF_CONFIG1_OVRD

Name: INTF_CONFIG1_OVRD Address: 45 (2Dh) Serial IF: R/W Reset value: 0x0C Clock Domain: SCLK		
BIT	NAME	FUNCTION
7:4	-	Reserved
3	AP_SPI_34_MODE_OVRD	0: Override disable for AP interface SPI 4-wire/3-wire modes 1: Override enable for AP interface SPI 4-wire/3-wire modes
2	AP_SPI_34_MODE_OVRD_VAL	Override value for AP interface SPI 4-wire/3-wire modes 0: SPI 3-wire mode 1: SPI 4-wire mode
1	AP_SPI_MODE_OVRD	0: Override disable for AP interface SPI_MODE value 1: Override enable for AP interface SPI_MODE value
0	AP_SPI_MODE_OVRD_VAL	Override value for AP interface SPI Mode 0: SPI mode 0 or 3 1: SPI mode 1 or 2

17.43 IOC_PAD_SCENARIO

Name: IOC_PAD_SCENARIO Address: 47 (2Fh) Serial IF: R Reset value: 0x09 Clock Domain: MCLK		
BIT	NAME	FUNCTION
7:3	-	Reserved
2:1	AUX1_MODE	Read only register field, effective only when AUX1_ENABLE is 1. Selects AUX1 mode: 00: Reserved 01: AUX1 in I2C Master mode 10: AUX1 in I2C Master Bypass mode (Enable only when AP is not in SPI mode) 11: Reserved
0	AUX1_ENABLE	Read only register field, enable or disable AUX1 0: AUX1 disabled 1: AUX1 enabled

17.44 IOC_PAD_SCENARIO_AUX_OVRD

Name: IOC_PAD_SCENARIO_AUX_OVRD Address: 48 (30h) Serial IF: R/W Reset value: 0x00 Clock Domain: MCLK		
BIT	NAME	FUNCTION
7:5	-	Reserved
4	AUX1_MODE_OVRD	Override enable for AUX1_MODE 0: Disable 1: Enable
3:2	AUX1_ENABLE_OVRD_VAL	Override value for AUX1_ENABLE. Effective only when AUX1_ENABLE is 1. Selects modes of AUX1 use: 0: Reserved 1: AUX1 in I2C Master mode 2: AUX1 in I2C Master Bypass mode (enable only when AP is not in SPI mode) Note: When enabling the I2C Master Bypass mode, this register should be programmed individually, not as part of a burst transaction.
1	AUX1_ENABLE_OVRD	Override enable for AUX1_ENABLE 0: Disable 1: Enable
0	AUX1_ENABLE_OVRD_VAL	Override value for AUX1_ENABLE 0: AUX1 disabled 1: AUX1 enabled

17.45 DRIVE_CONFIG0

Name: DRIVE_CONFIG0 Address: 50 (32h) Serial IF: R/W Reset value: 0x6C Clock Domain: MCLK		
BIT	NAME	FUNCTION
7	-	Reserved
6:4	PADS_I2C_SLEW	<p>Slew rate control for any pin in the I²C mode of operation, including pins on the AP serial interface when device is a client device of an I²C bus, including pins on the AUX1 serial interface when device is a master device of an I²C bus. Setting of the slew rate takes effect 1.5μs after the register is programmed.</p> <p>000: MIN: 3 ns; TYP: 20 ns; MAX: 136 ns 010: MIN: 2 ns; TYP: 7 ns; MAX: 84 ns Others: Reserved</p>
3:1	PADS_SPI_SLEW	<p>Slew rate control for any pin in the SPI mode of operation. Setting of the slew rate takes effect 1.5μs after the register is programmed.</p> <p>000: MIN: 12 ns; TYP: 38 ns; MAX: 106 ns 001: MIN: 4 ns; TYP: 14 ns; MAX: 45 ns 010: MIN: 3 ns; TYP: 10 ns; MAX: 37 ns 011: MIN: 2 ns; TYP: 7 ns; MAX: 25 ns 100: MIN: 1 ns; TYP: 5 ns; MAX: 17 ns 101: MIN: 1 ns; TYP: 4 ns; MAX: 14 ns 11x: MIN: 0.1 ns; TYP: 0.5 ns; MAX: 6 ns</p>
0	-	Reserved

17.46 DRIVE_CONFIG1

Name: DRIVE_CONFIG1 Address: 51 (33h) Serial IF: R/W Reset value: 0x36 Clock Domain: MCLK		
BIT	NAME	FUNCTION
7:6	-	Reserved
5:3	PADS_I3C_DDR_SLEW	Slew rate control when device is in I3C SM DDR protocol. Setting of the slew rate takes effect 1.5μs after the register is programmed. 000: MIN: 12 ns; TYP: 38 ns; MAX: 106 ns 001: MIN: 4 ns; TYP: 14 ns; MAX: 45 ns 010: MIN: 3 ns; TYP: 10 ns; MAX: 37 ns 011: MIN: 2 ns; TYP: 7 ns; MAX: 25 ns 100: MIN: 1 ns; TYP: 5 ns; MAX: 17 ns 101: MIN: 1 ns; TYP: 4 ns; MAX: 14 ns 11x: MIN: 0.1 ns; TYP: 0.5 ns; MAX: 6 ns
2:0	PADS_I3C_SDR_SLEW	Slew rate control when device is in I3C SM SDR protocol. Setting of the slew rate takes effect 1.5μs after the register is programmed. 000: MIN: 12 ns; TYP: 38 ns; MAX: 106 ns 001: MIN: 4 ns; TYP: 14 ns; MAX: 45 ns 010: MIN: 3 ns; TYP: 10 ns; MAX: 37 ns 011: MIN: 2 ns; TYP: 7 ns; MAX: 25 ns 100: MIN: 1 ns; TYP: 5 ns; MAX: 17 ns 101: MIN: 1 ns; TYP: 4 ns; MAX: 14 ns 11x: MIN: 0.1 ns; TYP: 0.5 ns; MAX: 6 ns

17.47 DRIVE_CONFIG2

Name: DRIVE_CONFIG2 Address: 52 (34h) Serial IF: R/W Reset value: 0x06 Clock Domain: MCLK		
BIT	NAME	FUNCTION
7:3	-	Reserved
2:0	PADS_SLEW	Slew rate control for INT1 pin at all times. Slew rate control for all pins before OTP copy operation is completed. Setting of the slew rate takes effect 1.5μs after the register is programmed. 000: MIN: 12 ns; TYP: 38 ns; MAX: 106 ns 001: MIN: 4 ns; TYP: 14 ns; MAX: 45 ns 010: MIN: 3 ns; TYP: 10 ns; MAX: 37 ns 011: MIN: 2 ns; TYP: 7 ns; MAX: 25 ns 100: MIN: 1 ns; TYP: 5 ns; MAX: 17 ns 101: MIN: 1 ns; TYP: 4 ns; MAX: 14 ns 11x: MIN: 0.1 ns; TYP: 0.5 ns; MAX: 6 ns

17.48 REG_MISC1

Name: REG_MISC1 Address: 53 (35h) Serial IF: R/W Reset value: 0x00 Clock Domain: MCLK		
BIT	NAME	FUNCTION
7:4	-	Reserved
3:0	OSC_ID_OVRD	Selects MCLK source. 0000: MCLK source requested by internal logic (default) 0010: Requests internal relaxation oscillator 1000: Requests external clock Rest: Reserved The selected clock source is the highest index that's requested and that is ready.

17.49 INT_APEX_CONFIG0

Name: INT_APEX_CONFIG0 Address: 57 (39h) Serial IF: R/W Reset value: 0x00 Clock Domain: MCLK		
BIT	NAME	FUNCTION
7	INT_STATUS_MASK_PIN_R2W_WAKE_DET	Enable interrupt pin assertion when the INT_STATUS_R2W_WAKE_DET status bit is 1. 0: Enable Interrupt pin assertion 1: No Interrupt pin assertion
6	INT_STATUS_MASK_PIN_FF_DET	Enable interrupt pin assertion when the INT_STATUS_FF_DET status bit is 1. 0: Enable Interrupt pin assertion 1: No Interrupt pin assertion
5	INT_STATUS_MASK_PIN_STEP_DET	Enable interrupt pin assertion when the INT_STATUS_STEP_DET status bit is 1. 0: Enable Interrupt pin assertion 1: No Interrupt pin assertion
4	INT_STATUS_MASK_PIN_STEP_CNT_OVFL	Enable interrupt pin assertion when the INT_STATUS_STEP_CNT_OVFL status bit is 1. 0: Enable Interrupt pin assertion 1: No Interrupt pin assertion
3	INT_STATUS_MASK_PIN_TILT_DET	Enable interrupt pin assertion when the INT_STATUS_TILT_DET status bit is 1. 0: Enable Interrupt pin assertion 1: No Interrupt pin assertion
2	INT_STATUS_MASK_PIN_LOW_G_DET	Enable interrupt pin assertion when the INT_STATUS_LOW_G_DET status bit is 1. 0: Enable Interrupt pin assertion 1: No Interrupt pin assertion
1	INT_STATUS_MASK_PIN_HIGH_G_DET	Enable interrupt pin assertion when the INT_STATUS_HIGH_G_DET status bit is 1. 0: Enable Interrupt pin assertion 1: No Interrupt pin assertion
0	INT_STATUS_MASK_PIN_TAP_DET	Enable interrupt pin assertion when the INT_STATUS_TAP_DET status bit is 1. 0: Enable Interrupt pin assertion 1: No Interrupt pin assertion

17.50 INT_APEX_CONFIG1

Name: INT_APEX_CONFIG1 Address: 58 (3Ah) Serial IF: R/W Reset value: 0x00 Clock Domain: MCLK		
BIT	NAME	FUNCTION
7:5	-	Reserved
4	INT_STATUS_MASK_PIN_SA_DONE	0: Enable interrupt generation when Secure Authentication is done 1: Disable interrupt generation for Secure Authentication
3	-	Reserved
2	INT_STATUS_MASK_PIN_SELF_TEST_DONE	0: Enable interrupt generation when self-test is done 1: Disable interrupt generation for self-test
1	INT_STATUS_MASK_PIN_SMD_DET	0: Enable interrupt generation for Significant Motion Detection (SMD) 1: Disable interrupt generation for Significant Motion Detection (SMD)
0	INT_STATUS_MASK_PIN_R2W_SLEEP_DET	0: Enable interrupt generation for Wake Sleep Detection 1: Disable interrupt generation for Wake Sleep Detection

17.51 INT_APEX_STATUS0

Name: INT_APEX_STATUS0 Address: 59 (3Bh) Serial IF: R/C Reset value: 0x00 Clock Domain: MCLK		
BIT	NAME	FUNCTION
7	INT_STATUS_R2W_WAKE_DET	0: Wake interrupt did not occur. 1: Wake interrupt occurred.
6	INT_STATUS_FF_DET	0: Freefall interrupt did not occur. 1: Freefall interrupt occurred.
5	INT_STATUS_STEP_DET	0: Step Detection interrupt did not occur. 1: Step Detection interrupt occurred.
4	INT_STATUS_STEP_CNT_OVERFLOW	0: Step-Count Overflow interrupt did not occur. 1: Step-Count Overflow interrupt occurred.
3	INT_STATUS_TILT_DET	0: Tilt Detection interrupt did not occur. 1: Tilt Detection interrupt occurred.
2	INT_STATUS_LOW_G_DET	0: LowG Detection interrupt did not occur. 1: LowG Detection interrupt occurred.
1	INT_STATUS_HIGH_G_DET	0: HighG Detection interrupt did not occur. 1: HighG Detection interrupt occurred.
0	INT_STATUS_TAP_DET	0: Tap Detection interrupt did not occur. 1: Tap Detection interrupt occurred.

17.52 INT_APEX_STATUS1

Name: INT_APEX_STATUS1 Address: 60 (3Ch) Serial IF: R/C Reset value: 0x00 Clock Domain: MCLK		
BIT	NAME	FUNCTION
7:5	-	Reserved
4	INT_STATUS_SA_DONE	For EDMP_OUT interface. 0: Secure Authentication interrupt did not occur. 1: Secure Authentication interrupt occurred.
3	-	Reserved
2	INT_STATUS_SELFTEST_DONE	0: Self-Test interrupt did not occur. 1: Self-Test interrupt occurred.
1	INT_STATUS_SMD_DET	This bit is set to 1 when Significant Motion Detection (SMD) interrupt is generated 0: Significant Motion Detection (SMD) interrupt did not occur. 1: Significant Motion Detection (SMD) interrupt occurred.
0	INT_STATUS_R2W_SLEEP_DE T	0: Sleep interrupt did not occur. 1: Sleep interrupt occurred.

17.53 INT2_CONFIG0

Name: INT2_CONFIG0 Address: 86 (56h) Serial IF: R/W Reset value: 0x80 Clock Domain: MCLK		
BIT	NAME	FUNCTION
7	INT2_STATUS_EN_RESET_DONE	Enable interrupt status bit to flag the occurrence of Reset Done event on INT2 0: Disable interrupt. 1: Enable interrupt. Setting can be changed by UI or AUX1 interface.
6	INT2_STATUS_EN_AUX1_AGC_RDY	Enable interrupt status bit to flag the occurrence of AUX1 AGC Ready event on INT2 0: Disable interrupt. 1: Enable interrupt. Setting can be changed by UI or AUX1 interface.
5	INT2_STATUS_EN_AP_AGC_RDY	Enable interrupt status bit to flag the occurrence of UI AGC Ready event on INT2 0: Disable interrupt. 1: Enable interrupt. Setting can be changed by UI or AUX1 interface.
4	INT2_STATUS_EN_AP_FSYNC	Enable interrupt status bit to flag the occurrence of UI FSYNC event on INT2 0: Disable interrupt. 1: Enable interrupt. Setting can be changed by UI or AUX1 interface.
3	INT2_STATUS_EN_AUX1_DRDY	Enable interrupt status bit to flag the occurrence of AUX1 Data Ready event on INT2 0: Disable interrupt. 1: Enable interrupt. Setting can be changed by UI or AUX1 interface.
2	INT2_STATUS_EN_DRDY	Enable interrupt status bit to flag the occurrence of UI Data Ready event on INT2 0: Disable interrupt. 1: Enable interrupt. Setting can be changed by UI or AUX1 interface.
1	INT2_STATUS_EN_FIFO_THRESHOLD	Enable interrupt status bit to flag the occurrence of FIFO count \geq FIFO threshold event on INT2

		<p>0: Disable interrupt. 1: Enable interrupt.</p> <p>Setting can be changed by UI or AUX1 interface.</p>
0	INT2_STATUS_EN_FIFO_FULL	<p>Enable interrupt status bit to flag the occurrence of FIFO full event on INT2</p> <p>0: Disable interrupt. 1: Enable interrupt.</p> <p>Setting can be changed by UI or AUX1 interface.</p>

17.54 INT2_CONFIG1

Name: INT2_CONFIG1 Address: 87 (57h) Serial IF: R/W Reset value: 0x00 Clock Domain: MCLK		
BIT	NAME	FUNCTION
7	-	Reserved
6	INT2_STATUS_EN_APEX_EVENT	Enable interrupt status bit to flag the occurrence of APEX event on INT2 0: Disable interrupt. 1: Enable interrupt. Setting can be changed by UI interface.
5	INT2_STATUS_EN_I2CM_DONE	Enable interrupt status bit to flag the completion of I ² C master event on INT2 0: Disable interrupt. 1: Enable interrupt. Setting can be changed by UI interface.
4	INT2_STATUS_EN_I3C_PROTOCOL_ERR	Enable interrupt status bit to flag the occurrence of I3C Protocol Error event on INT2 0: Disable interrupt. 1: Enable interrupt. Setting can be changed by UI interface.
3	INT2_STATUS_EN_WOM_Z	Enable interrupt status bit to flag the occurrence of WOM on Z-axis event on INT2 0: Disable interrupt. 1: Enable interrupt. Setting can be changed by UI interface.
2	INT2_STATUS_EN_WOM_Y	Enable interrupt status bit to flag the occurrence of WOM on Y-axis event on INT2 0: Disable interrupt. 1: Enable interrupt. Setting can be changed by UI interface.
1	INT2_STATUS_EN_WOM_X	Enable interrupt status bit to flag the occurrence of WOM on X-axis event on INT2 0: Disable interrupt. 1: Enable interrupt. Setting can be changed by UI interface.
0	INT2_STATUS_EN_PLL_RDY	Enable interrupt status bit to flag the occurrence of PLL Ready event on INT2 0: Disable interrupt.

		1: Enable interrupt. Setting can be changed by UI interface.
--	--	---

17.55 INT2_CONFIG2

Name: INT2_CONFIG2 Address: 88 (58h) Serial IF: R/W Reset value: 0x04 Clock Domain: MCLK		
BIT	NAME	FUNCTION
7:3	-	Reserved
2	INT2_DRIVE	Sets INT2 to open-drain or push-pull 0: Push-pull 1: Open-drain
1	INT2_MODE	INT2 interrupt mode 0: Pulse mode 1: Latch mode Setting can be changed only when all interrupts of the corresponding serial interface are disabled
0	INT2_POLARITY	INT2 interrupt polarity 0: Active low 1: Active high Setting can be changed only when all interrupts of the corresponding serial interface are disabled

17.56 INT2_STATUS0

Name: INT2_STATUS0 Address: 89 (59h) Serial IF: R/C Reset value: 0x00 Clock Domain: MCLK		
BIT	NAME	FUNCTION
7	INT2_STATUS_RESET_DONE	Flags the occurrence of Reset Done event on INT2 0: Interrupt did not occur 1: Interrupt occurred
6	INT2_STATUS_AUX1_AGC_RDY	Flags the occurrence of AUX1 AGC Ready event on INT2 0: Interrupt did not occur 1: Interrupt occurred
5	INT2_STATUS_AP_AGC_RDY	Flags the occurrence of UI AGC Ready event on INT2 0: Interrupt did not occur 1: Interrupt occurred
4	INT2_STATUS_AP_FSYNC	Flags the occurrence of UI FSYNC event on INT2 0: Interrupt did not occur 1: Interrupt occurred
3	INT2_STATUS_AUX1_DRDY	Flags the occurrence of AUX1 Data Ready event on INT2 0: Interrupt did not occur 1: Interrupt occurred
2	INT2_STATUS_DRDY	Flags the occurrence of UI Data Ready event on INT2 0: Interrupt did not occur 1: Interrupt occurred
1	INT2_STATUS_FIFO_THS	Flags the occurrence of FIFO count \geq FIFO threshold event on INT2 0: Interrupt did not occur 1: Interrupt occurred
0	INT2_STATUS_FIFO_FULL	Flags the occurrence of FIFO full event on INT2 0: Interrupt did not occur 1: Interrupt occurred

17.57 INT2_STATUS1

Name: INT2_STATUS1 Address: 90 (5Ah) Serial IF: R/C Reset value: 0x00 Clock Domain: MCLK		
BIT	NAME	FUNCTION
7	-	Reserved
6	INT2_STATUS_APEX_EVENT	Flags the occurrence of APEX event on INT2 0: Interrupt did not occur 1: Interrupt occurred
5	INT2_STATUS_I2CM_DONE	Flags the occurrence of I ² C Master Done event on INT2 0: Interrupt did not occur 1: Interrupt occurred
4	INT2_STATUS_I3C_PROTOCOL_ERR	Flags the occurrence of I3C SM Protocol Error event on INT2 0: Interrupt did not occur 1: Interrupt occurred
3	INT2_STATUS_WOM_Z	Flags the occurrence of Z-axis WOM event on INT2 0: Interrupt did not occur 1: Interrupt occurred
2	INT2_STATUS_WOM_Y	Flags the occurrence of Y-axis WOM event on INT2 0: Interrupt did not occur 1: Interrupt occurred
1	INT2_STATUS_WOM_X	Flags the occurrence of X-axis WOM event on INT2 0: Interrupt did not occur 1: Interrupt occurred
0	INT2_STATUS_PLL_RDY	Flags the occurrence of PLL Ready event on INT2 0: Interrupt did not occur 1: Interrupt occurred

17.58 WHO_AM_I

Name: WHO_AM_I Address: 114 (72h) Serial IF: R Reset value: 0xE5 Clock Domain: ALL		
BIT	NAME	FUNCTION
7:0	WHOAMI	Register to indicate to user which device is being accessed

Description:

This register is used to verify the identity of the device. The contents of WHOAMI is an 8-bit device ID. The default value of the register is 0xE5. This is different from the I²C address of the device as seen on the slave I²C controller by the applications processor.

17.59 REG_HOST_MSG

Name: REG_HOST_MSG Address: 115 (73h) Serial IF: R/W Reset value: 0x00 Clock Domain: SCLK		
BIT	NAME	FUNCTION
7:6	-	Reserved
5	EDMP_ON_DEMAND_EN	When set, a trigger will be sent which will cause the eDMP to run once. It is automatically reset to 0.
4:1	-	Reserved
0	TESTOPENABLE	1: Enable test operation

17.60 IREG_ADDR_15_8

Name: IREG_ADDR_15_8 Address: 124 (7Ch) Serial IF: R/W Reset value: 0xAF Clock Domain: SCLK		
BIT	NAME	FUNCTION
7:0	IREG_ADDR_15_8	Address bit[15:8] of the 16-bit indirect address for assessing indirect access registers (IREG) Can be changed on-the-fly.

17.61 IREG_ADDR_7_0

Name: IREG_ADDR_7_0 Address: 125 (7Dh) Serial IF: R/W Reset value: 0x06 Clock Domain: SCLK		
BIT	NAME	FUNCTION
7:0	IREG_ADDR_7_0	Address bit[7:0] of the 16-bit indirect address for assessing indirect access registers (IREG) Can be changed on-the-fly.

17.62 IREG_DATA

Name: IREG_DATA Address: 126 (7Eh) Serial IF: R/W Reset value: 0x02 Clock Domain: SCLK		
BIT	NAME	FUNCTION
7:0	IREG_DATA	Register for indirect access registers (IREG) data read/write operations. Can be changed on-the-fly.

17.63 REG_MISC2

Name: REG_MISC2 Address: 127 (7Fh) Serial IF: R/W Reset value: 0x01 Clock Domain: SCLK		
BIT	NAME	FUNCTION
7:2	-	Reserved
1	SOFT_RST	0: Soft reset not enabled. 1: Triggers soft reset operation. The programmed value of 1 is self-cleared to 0 upon completion of soft reset operation. Can be changed on-the-fly.
0	IREG_DONE	0: Indicates that an indirect register access operation is in progress. No new indirect register access should be triggered. 1: Indirect register access has completed. New indirect register access can be triggered.

18 USER BANK IMEM_SRAM REGISTER MAP – DESCRIPTIONS

This section describes the function and contents of each register within user bank IMEM_SRAM. The registers described in this section are indirect access registers. Section 13 describes the procedure for accessing indirect access registers.

18.1 IMEM_SRAM_REG_0

Name: IMEM_SRAM_REG_0 Address: 00 (00h) Serial IF: R/W Reset value: Random value after reset until host runs EDMP_INIT procedure Clock Domain: MCLK		
BIT	NAME	FUNCTION
7:0	GYRO_X_STR_FT[7:0]	Self-test response for gyro X-axis. Units are in kdps. Full scale is 0.5kdps, LSB is 30mdps.

18.2 IMEM_SRAM_REG_1

Name: IMEM_SRAM_REG_1 Address: 01 (01h) Serial IF: R/W Reset value: Random value after reset until host runs EDMP_INIT procedure Clock Domain: MCLK		
BIT	NAME	FUNCTION
7:0	GYRO_X_STR_FT[15:8]	Self-test response for gyro X-axis. Units are in kdps. Full scale is 0.5kdps, LSB is 30mdps.

18.3 IMEM_SRAM_REG_2

Name: IMEM_SRAM_REG_2 Address: 02 (02h) Serial IF: R/W Reset value: Random value after reset until host runs EDMP_INIT procedure Clock Domain: MCLK		
BIT	NAME	FUNCTION
7:0	GYRO_Y_STR_FT[7:0]	Self-test response for gyro Y-axis. Units are in kdps. Full scale is 0.5kdps, LSB is 30mdps.

18.4 IMEM_SRAM_REG_3

Name: IMEM_SRAM_REG_3 Address: 03 (03h) Serial IF: R/W Reset value: Random value after reset until host runs EDMP_INIT procedure Clock Domain: MCLK		
BIT	NAME	FUNCTION
7:0	GYRO_Y_STR_FT[15:8]	Self-test response for gyro Y-axis. Units are in kdps. Full scale is 0.5kdps, LSB is 30mdps.

18.5 IMEM_SRAM_REG_4

Name: IMEM_SRAM_REG_4		
Address: 04 (04h)		
Serial IF: R/W		
Reset value: Random value after reset until host runs EDMP_INIT procedure		
Clock Domain: MCLK		
BIT	NAME	FUNCTION
7:0	GYRO_Z_STR_FT[7:0]	Self-test response for gyro Z-axis. Units are in kdps. Full scale is 0.5kdps, LSB is 30mdps.

18.6 IMEM_SRAM_REG_5

Name: IMEM_SRAM_REG_5		
Address: 05 (05h)		
Serial IF: R/W		
Reset value: Random value after reset until host runs EDMP_INIT procedure		
Clock Domain: MCLK		
BIT	NAME	FUNCTION
7:0	GYRO_Z_STR_FT[15:8]	Self-test response for gyro Z-axis. Units are in kdps. Full scale is 0.5kdps, LSB is 30mdps.

18.7 IMEM_SRAM_REG_6

Name: IMEM_SRAM_REG_6		
Address: 06 (06h)		
Serial IF: R/W		
Reset value: Random value after reset until host runs EDMP_INIT procedure		
Clock Domain: MCLK		
BIT	NAME	FUNCTION
7:0	GYRO_X_CMOS_GAIN_FT[7:0]	Gyro X-axis gain measurement result. Units are in kdps. FSR is 500 dps, resolution is 122 mdps.

18.8 IMEM_SRAM_REG_7

Name: IMEM_SRAM_REG_7		
Address: 07 (07h)		
Serial IF: R/W		
Reset value: Random value after reset until host runs EDMP_INIT procedure		
Clock Domain: MCLK		
BIT	NAME	FUNCTION
7:4	-	Reserved
3:0	GYRO_X_CMOS_GAIN_FT[11:8]	Gyro X-axis gain measurement result. Units are in kdps. FSR is 500 dps, resolution is 122 mdps.

18.9 IMEM_SRAM_REG_8

Name: IMEM_SRAM_REG_8 Address: 08 (08h) Serial IF: R/W Reset value: Random value after reset until host runs EDMP_INIT procedure Clock Domain: MCLK		
BIT	NAME	FUNCTION
7:0	GYRO_Y_CMOS_GAIN_FT[7:0]	Gyro Y-axis gain measurement result. Units are in kdps. FSR is 500 dps, resolution is 122 mdps.

18.10 IMEM_SRAM_REG_9

Name: IMEM_SRAM_REG_9 Address: 09 (09h) Serial IF: R/W Reset value: Random value after reset until host runs EDMP_INIT procedure Clock Domain: MCLK		
BIT	NAME	FUNCTION
7:4	-	Reserved
3:0	GYRO_Y_CMOS_GAIN_FT [11:8]	Gyro Y-axis gain measurement result. Units are in kdps. FSR is 500 dps, resolution is 122 mdps.

18.11 IMEM_SRAM_REG_10

Name: IMEM_SRAM_REG_10 Address: 10 (0Ah) Serial IF: R/W Reset value: Random value after reset until host runs EDMP_INIT procedure Clock Domain: MCLK		
BIT	NAME	FUNCTION
7:0	GYRO_Z_CMOS_GAIN_FT[7:0]	Gyro Z-axis gain measurement result. Units are in kdps. FSR is 500 dps, resolution is 122 mdps.

18.12 IMEM_SRAM_REG_11

Name: IMEM_SRAM_REG_11 Address: 11 (0Bh) Serial IF: R/W Reset value: Random value after reset until host runs EDMP_INIT procedure Clock Domain: MCLK		
BIT	NAME	FUNCTION
7:4	-	Reserved
3:0	GYRO_Z_CMOS_GAIN_FT [11:8]	Gyro Z-axis gain measurement result. Units are in kdps. FSR is 500 dps, resolution is 122 mdps.

18.13 IMEM_SRAM_REG_56

Name: IMEM_SRAM_REG_56		
Address: 56 (38h)		
Serial IF: R/W		
Reset value: Random value after reset until host runs EDMP_INIT procedure		
Clock Domain: MCLK		
BIT	NAME	FUNCTION
7	ST_AVG_TIME[0]	Averaging time used to perform self-test (ST_AVG_TIME[2:1] in IMEM_SRAM_REG_57) 000: 10ms 001: 20ms 010: 40ms 011: 80ms 100: 160ms 101: 320ms Rest: Reserved
6:3	-	Reserved
2	ST_GYRO_EN	1: Enable gyro self-test operation
1	ST_ACCEL_EN	1: Enable accel self-test operation
0	STC_INIT_EN	1: Initializes self-test parameters

18.14 IMEM_SRAM_REG_57

Name: IMEM_SRAM_REG_57		
Address: 57 (39h)		
Serial IF: R/W		
Reset value: Random value after reset until host runs EDMP_INIT procedure		
Clock Domain: MCLK		
BIT	NAME	FUNCTION
7:5	ST_GYRO_LIMIT	Tolerance between factory trim and gyro self-test response 000: 5% 001: 10% 010: 15% 011: 20% 100: 25% 101: 30% 110: 40% 111: 50%
4:2	ST_ACCEL_LIMIT	Tolerance between factory trim and accel self-test response 000: 5% 001: 10% 010: 15% 011: 20% 100: 25% 101: 30% 110: 40% 111: 50%

1:0	ST_AVG_TIME[2:1]	<p>Averaging time used to perform self-test (ST_AVG_TIME[0] in IMEM_SRAM_REG_56)</p> <p>000: 10ms 001: 20ms 010: 40ms 011: 80ms 100: 160ms 101: 320ms Rest: Reserved</p>
-----	------------------	--

18.15 IMEM_SRAM_REG_64

Name: IMEM_SRAM_REG_64 Address: 64 (40h) Serial IF: R/W Reset value: Random value after reset until host runs EDMP_INIT procedure Clock Domain: MCLK		
BIT	NAME	FUNCTION
7:0	ST_DEBUG_EN	Debug capability of self-test feature. Must be set to 0 whenever self-test is requested.

18.16 IMEM_SRAM_REG_68

Name: IMEM_SRAM_REG_68 Address: 68 (44h) Serial IF: R Reset value: Random value after reset until host runs EDMP_INIT procedure Clock Domain: MCLK		
BIT	NAME	FUNCTION
7:6	ST_STATUS	Self-test status (gyro or accel) 00: Done 01: In Progress 10: Error 11: Reserved
5	GZ_ST_PASS	1: Gyro Z-axis self-test passed
4	GY_ST_PASS	1: Gyro Y-axis self-test passed
3	GX_ST_PASS	1: Gyro X-axis self-test passed
2	AZ_ST_PASS	1: Accel Z-axis self-test passed
1	AY_ST_PASS	1: Accel Y-axis self-test passed
0	AX_ST_PASS	1: Accel X-axis self-test passed

18.17 IMEM_SRAM_REG_92

Name: IMEM_SRAM_REG_92 Address: 92 (5Ch) Serial IF: R/W Reset value: Random value after reset until host runs EDMP_INIT procedure Clock Domain: MCLK		
BIT	NAME	FUNCTION
7:0	QUAT_RESET_EN	Set 1 to force reset 3-axis quaternion when next tilt reset is done. This is applicable only if TILT_RESET_EN is also set to 1. Range: [0 – 1] Default: 0

18.18 IMEM_SRAM_REG_96

Name: IMEM_SRAM_REG_96 Address: 96 (60h) Serial IF: R/W Reset value: Random value after reset until host runs EDMP_INIT procedure Clock Domain: MCLK		
BIT	NAME	FUNCTION
7:0	STC_GAIN_GX[7:0]	Gyro measurements for X-axis in s32.16 for gyro self-test

18.19 IMEM_SRAM_REG_97

Name: IMEM_SRAM_REG_97 Address: 97 (61h) Serial IF: R/W Reset value: Random value after reset until host runs EDMP_INIT procedure Clock Domain: MCLK		
BIT	NAME	FUNCTION
7:0	STC_GAIN_GX[15:8]	Gyro measurements for X-axis in s32.16 for gyro self-test

18.20 IMEM_SRAM_REG_98

Name: IMEM_SRAM_REG_98 Address: 98 (62h) Serial IF: R/W Reset value: Random value after reset until host runs EDMP_INIT procedure Clock Domain: MCLK		
BIT	NAME	FUNCTION
7:0	STC_GAIN_GX[23:16]	Gyro measurements for X-axis in s32.16 for gyro self-test

18.21 IMEM_SRAM_REG_99

Name: IMEM_SRAM_REG_99		
Address: 99 (63h)		
Serial IF: R/W		
Reset value: Random value after reset until host runs EDMP_INIT procedure		
Clock Domain: MCLK		
BIT	NAME	FUNCTION
7:0	STC_GAIN_GX[31:24]	Gyro measurements for X-axis in s32.16 for gyro self-test

18.22 IMEM_SRAM_REG_100

Name: IMEM_SRAM_REG_100		
Address: 100 (64h)		
Serial IF: R/W		
Reset value: Random value after reset until host runs EDMP_INIT procedure		
Clock Domain: MCLK		
BIT	NAME	FUNCTION
7:0	STC_GAIN_GY[7:0]	Gyro measurements for Y-axis in s32.16 for gyro self-test

18.23 IMEM_SRAM_REG_101

Name: IMEM_SRAM_REG_101		
Address: 101 (65h)		
Serial IF: R/W		
Reset value: Random value after reset until host runs EDMP_INIT procedure		
Clock Domain: MCLK		
BIT	NAME	FUNCTION
7:0	STC_GAIN_GY[15:8]	Gyro measurements for Y-axis in s32.16 for gyro self-test

18.24 IMEM_SRAM_REG_102

Name: IMEM_SRAM_REG_102		
Address: 102 (66h)		
Serial IF: R/W		
Reset value: Random value after reset until host runs EDMP_INIT procedure		
Clock Domain: MCLK		
BIT	NAME	FUNCTION
7:0	STC_GAIN_GY[23:16]	Gyro measurements for Y-axis in s32.16 for gyro self-test

18.25 IMEM_SRAM_REG_103

Name: IMEM_SRAM_REG_103		
Address: 103 (67h)		
Serial IF: R/W		
Reset value: Random value after reset until host runs EDMP_INIT procedure		
Clock Domain: MCLK		
BIT	NAME	FUNCTION
7:0	STC_GAIN_GY[31:24]	Gyro measurements for Y-axis in s32.16 for gyro self-test

18.26 IMEM_SRAM_REG_104

Name: IMEM_SRAM_REG_104		
Address: 104 (68h)		
Serial IF: R/W		
Reset value: Random value after reset until host runs EDMP_INIT procedure		
Clock Domain: MCLK		
BIT	NAME	FUNCTION
7:0	STC_GAIN_GZ[7:0]	Gyro measurements for Z-axis in s32.16 for gyro self-test

18.27 IMEM_SRAM_REG_105

Name: IMEM_SRAM_REG_105		
Address: 105 (69h)		
Serial IF: R/W		
Reset value: Random value after reset until host runs EDMP_INIT procedure		
Clock Domain: MCLK		
BIT	NAME	FUNCTION
7:0	STC_GAIN_GZ[15:8]	Gyro measurements for Z-axis in s32.16 for gyro self-test

18.28 IMEM_SRAM_REG_106

Name: IMEM_SRAM_REG_106		
Address: 106 (6Ah)		
Serial IF: R/W		
Reset value: Random value after reset until host runs EDMP_INIT procedure		
Clock Domain: MCLK		
BIT	NAME	FUNCTION
7:0	STC_GAIN_GZ[23:16]	Gyro measurements for Z-axis in s32.16 for gyro self-test

18.29 IMEM_SRAM_REG_107

Name: IMEM_SRAM_REG_107		
Address: 107 (6Bh)		
Serial IF: R/W		
Reset value: Random value after reset until host runs EDMP_INIT procedure		
Clock Domain: MCLK		
BIT	NAME	FUNCTION
7:0	STC_GAIN_GZ[31:24]	Gyro measurements for Z-axis in s32.16 for gyro self-test

18.30 IMEM_SRAM_REG_136

Name: IMEM_SRAM_REG_136 Address: 136 (88h) Serial IF: R/W Reset value: Random value after reset until host runs EDMP_INIT procedure Clock Domain: MCLK		
BIT	NAME	FUNCTION
7:0	FF_DURATION_BUF1[7:0]	Duration of the freefall in number of samples. Filled in alternatively with FF_DURATION_BUF2. Unit: Number of samples. Freefall duration in seconds is FF_DURATION_BUF1 / ACCEL_ODR (in Hz)

18.31 IMEM_SRAM_REG_137

Name: IMEM_SRAM_REG_137 Address: 137 (89h) Serial IF: R/W Reset value: Random value after reset until host runs EDMP_INIT procedure Clock Domain: MCLK		
BIT	NAME	FUNCTION
7:0	FF_DURATION_BUF1[15:8]	Duration of the freefall in number of samples. Filled in alternatively with FF_DURATION_BUF2. Unit: Number of samples. Freefall duration in seconds is FF_DURATION_BUF1 / ACCEL_ODR (in Hz)

18.32 IMEM_SRAM_REG_138

Name: IMEM_SRAM_REG_138 Address: 138 (8Ah) Serial IF: R/W Reset value: Random value after reset until host runs EDMP_INIT procedure Clock Domain: MCLK		
BIT	NAME	FUNCTION
7:0	FF_DURATION_BUF2[7:0]	Duration of the freefall in number of samples. Filled in alternatively with FF_DURATION_BUF1. Unit: Number of samples. Freefall duration in seconds is FF_DURATION_BUF2 / ACCEL_ODR (in Hz)

18.33 IMEM_SRAM_REG_139

Name: IMEM_SRAM_REG_139 Address: 139 (8Bh) Serial IF: R/W Reset value: Random value after reset until host runs EDMP_INIT procedure Clock Domain: MCLK		
BIT	NAME	FUNCTION
7:0	FF_DURATION_BUF2[15:8]	Duration of the freefall in number of samples. Filled in alternatively with FF_DURATION_BUF1. Unit: Number of samples. Freefall duration in seconds is FF_DURATION_BUF2 / ACCEL_ODR (in Hz)

18.34 IMEM_SRAM_REG_141

Name: IMEM_SRAM_REG_141 Address: 141 (8Dh) Serial IF: R/W Reset value: Random value after reset until host runs EDMP_INIT procedure Clock Domain: MCLK		
BIT	NAME	FUNCTION
7:0	TAP_NUM	Type of the last reported TAP event: 0: no tap, 1: single tap, 2: double tap

18.35 IMEM_SRAM_REG_142

Name: IMEM_SRAM_REG_142 Address: 142 (8Eh) Serial IF: R/W Reset value: Random value after reset until host runs EDMP_INIT procedure Clock Domain: MCLK		
BIT	NAME	FUNCTION
7:0	TAP_AXIS	Indicates the axis of the tap in the device frame 0: AX, 1: AY, 2: AZ

18.36 IMEM_SRAM_REG_143

Name: IMEM_SRAM_REG_143 Address: 143 (8Fh) Serial IF: R/W Reset value: Random value after reset until host runs EDMP_INIT procedure Clock Domain: MCLK		
BIT	NAME	FUNCTION
7:0	TAP_DIR	Indicates the direction of the tap in the device frame 0: Positive, 1: Negative

18.37 IMEM_SRAM_REG_144

Name: IMEM_SRAM_REG_144 Address: 144 (90h) Serial IF: R/W Reset value: Random value after reset until host runs EDMP_INIT procedure Clock Domain: MCLK		
BIT	NAME	FUNCTION
7:0	DOUBLE_TAP_TIMING	Indicate in case of double tap, the sample count between the 2 detected pulses In case of double tap, indicates the sample count between the two detected pulses. Double tap timing in seconds is DOUBLE_TAP_TIMING / ACCEL_ODR (in Hz).

18.38 IMEM_SRAM_REG_146

Name: IMEM_SRAM_REG_146 Address: 146 (92h) Serial IF: R/W Reset value: Random value after reset until host runs EDMP_INIT procedure Clock Domain: MCLK		
BIT	NAME	FUNCTION
7:0	TILT_RESET_EN	Set 1 to reset tilt prior to any further tilt processing on next sensor data. Range: [0 - 1] Default: 0

18.39 IMEM_SRAM_REG_154

Name: IMEM_SRAM_REG_154 Address: 154 (9Ah) Serial IF: R/W Reset value: Random value after reset until host runs EDMP_INIT procedure Clock Domain: MCLK		
BIT	NAME	FUNCTION
7:0	PED_STEP_CNT_BUF1[7:0]	Number of steps done since the last init of the pedometer feature. Filled in alternatively with PED_STEP_CNT_BUF2. Unit: number of steps

18.40 IMEM_SRAM_REG_155

Name: IMEM_SRAM_REG_155 Address: 155 (9Bh) Serial IF: R/W Reset value: Random value after reset until host runs EDMP_INIT procedure Clock Domain: MCLK		
BIT	NAME	FUNCTION
7:0	PED_STEP_CNT_BUF1[15:8]	Number of steps done since the last init of the pedometer feature. Filled in alternatively with PED_STEP_CNT_BUF2. Unit: number of steps

18.41 IMEM_SRAM_REG_156

Name: IMEM_SRAM_REG_156 Address: 156 (9Ch) Serial IF: R/W Reset value: Random value after reset until host runs EDMP_INIT procedure Clock Domain: MCLK		
BIT	NAME	FUNCTION
7:0	PED_STEP_CNT_BUF2[7:0]	Number of steps done since the last init of the pedometer feature. Filled in alternatively with PED_STEP_CNT_BUF1. Unit: number of steps

18.42 IMEM_SRAM_REG_157

Name: IMEM_SRAM_REG_157 Address: 157 (9Dh) Serial IF: R/W Reset value: Random value after reset until host runs EDMP_INIT procedure Clock Domain: MCLK		
BIT	NAME	FUNCTION
7:0	PED_STEP_CNT_BUF2[15:8]]	Number of steps done since the last init of the pedometer feature. Filled in alternatively with PED_STEP_CNT_BUF1. Unit: number of steps

18.43 IMEM_SRAM_REG_159

Name: IMEM_SRAM_REG_159 Address: 159 (9Fh) Serial IF: R/W Reset value: Random value after reset until host runs EDMP_INIT procedure Clock Domain: MCLK		
BIT	NAME	FUNCTION
7:0	PED_STEP_CADENCE	Instant step cadence measured by the algorithm Unit: 4*number of samples between two consecutive steps. Cadency (step/s) = (ped_step_cadence / 4) / (pedometer_ODR).

18.44 IMEM_SRAM_REG_160

Name: IMEM_SRAM_REG_160 Address: 160 (A0h) Serial IF: R/W Reset value: Random value after reset until host runs EDMP_INIT procedure Clock Domain: MCLK		
BIT	NAME	FUNCTION
7:0	POWER_ACTIVITY_CLASS	Activity classification of step detected 00000000: Unknown 00000001: Walk 00000010: Run Others: Reserved

18.45 IMEM_SRAM_REG_182

Name: IMEM_SRAM_REG_182 Address: 182 (B6h) Serial IF: R/W Reset value: Random value after reset until host runs EDMP_INIT procedure Clock Domain: MCLK		
BIT	NAME	FUNCTION
7:0	ES_RAM_IMAGE_EN	Set 1 to load device specific RAM image for external sensor support, otherwise set 0

18.46 IMEM_SRAM_REG_185

Name: IMEM_SRAM_REG_185		
Address: 185 (B9h)		
Serial IF: R/W		
Reset value: Random value after reset until host runs EDMP_INIT procedure		
Clock Domain: MCLK		
BIT	NAME	FUNCTION
7:0	ES0_COMPASS_EN	Set 1 for compass support with es0, for other external sensors with es0, set 0

18.47 IMEM_SRAM_REG_186

Name: IMEM_SRAM_REG_186		
Address: 186 (BAh)		
Serial IF: R/W		
Reset value: Random value after reset until host runs EDMP_INIT procedure		
Clock Domain: MCLK		
BIT	NAME	FUNCTION
7:0	ES_POWER_MODE	Set 1 for possibility of power savings when APEX features utilization is minimal. Set 0 when APEX features utilization is at maximum.

18.48 IMEM_SRAM_REG_196

Name: IMEM_SRAM_REG_196		
Address: 196 (C4h)		
Serial IF: R/W		
Reset value: Random value after reset until host runs EDMP_INIT procedure		
Clock Domain: MCLK		
BIT	NAME	FUNCTION
7:0	POWER_SAVE_TIME[7:0]	Time of inactivity after which eDMP goes into power save mode. Units: Time in sample number Range: [0 - 4294967295] Default: 6400 corresponding to 8s for ODR = 800Hz

18.49 IMEM_SRAM_REG_197

Name: IMEM_SRAM_REG_197		
Address: 197 (C5h)		
Serial IF: R/W		
Reset value: Random value after reset until host runs EDMP_INIT procedure		
Clock Domain: MCLK		
BIT	NAME	FUNCTION
7:0	POWER_SAVE_TIME[15:8]	Time of inactivity after which eDMP goes into power save mode. Units: Time in sample number Range: [0 - 4294967295] Default: 6400 corresponding to 8s for ODR = 800Hz

18.50 IMEM_SRAM_REG_198

Name: IMEM_SRAM_REG_198 Address: 198 (C6h) Serial IF: R/W Reset value: Random value after reset until host runs EDMP_INIT procedure Clock Domain: MCLK		
BIT	NAME	FUNCTION
7:0	POWER_SAVE_TIME[23:16]	Time of inactivity after which eDMP goes into power save mode. Units: Time in sample number Range: [0 - 4294967295] Default: 6400 corresponding to 8s for ODR = 800Hz

18.51 IMEM_SRAM_REG_199

Name: IMEM_SRAM_REG_199 Address: 199 (C7h) Serial IF: R/W Reset value: Random value after reset until host runs EDMP_INIT procedure Clock Domain: MCLK		
BIT	NAME	FUNCTION
7:0	POWER_SAVE_TIME[31:24]	Time of inactivity after which eDMP goes into power save mode. Units: Time in sample number Range: [0 - 4294967295] Default: 6400 corresponding to 8s for ODR = 800Hz

18.52 IMEM_SRAM_REG_288

Name: IMEM_SRAM_REG_288 Address: 288 (120h) Serial IF: R/W Reset value: Random value after reset until host runs EDMP_INIT procedure Clock Domain: MCLK		
BIT	NAME	FUNCTION
7:0	FF_MIN_DURATION[7:0]	Minimum freefall duration. Shorter freefalls are ignored. Unit: time in samples number Range: [4 - 420] Default: 57 (set for default ODR = 400 Hz, equivalent to 142 ms)

18.53 IMEM_SRAM_REG_289

Name: IMEM_SRAM_REG_289 Address: 289 (121h) Serial IF: R/W Reset value: Random value after reset until host runs EDMP_INIT procedure Clock Domain: MCLK		
BIT	NAME	FUNCTION
7:0	FF_MIN_DURATION[15:8]	Minimum freefall duration. Shorter freefalls are ignored. Unit: time in samples number Range: [4 - 420] Default: 57 (set for default ODR = 400 Hz, equivalent to 142 ms)

18.54 IMEM_SRAM_REG_290

Name: IMEM_SRAM_REG_290 Address: 290 (122h) Serial IF: R/W Reset value: Random value after reset until host runs EDMP_INIT procedure Clock Domain: MCLK		
BIT	NAME	FUNCTION
7:0	FF_MIN_DURATION[23:16]	Minimum freefall duration. Shorter freefalls are ignored. Unit: time in samples number Range: [4 - 420] Default: 57 (set for default ODR = 400 Hz, equivalent to 142 ms)

18.55 IMEM_SRAM_REG_291

Name: IMEM_SRAM_REG_291 Address: 291 (123h) Serial IF: R/W Reset value: Random value after reset until host runs EDMP_INIT procedure Clock Domain: MCLK		
BIT	NAME	FUNCTION
7:0	FF_MIN_DURATION[31:24]	Minimum freefall duration. Shorter freefalls are ignored. Unit: time in samples number Range: [4 - 420] Default: 57 (set for default ODR = 400 Hz, equivalent to 142 ms)

18.56 IMEM_SRAM_REG_292

Name: IMEM_SRAM_REG_292 Address: 292 (124h) Serial IF: R/W Reset value: Random value after reset until host runs EDMP_INIT procedure Clock Domain: MCLK		
BIT	NAME	FUNCTION
7:0	FF_MAX_DURATION[7:0]	Maximum freefall duration. Longer freefalls are ignored. Unit: time in samples number Range: [12 - 1040] Default: 285 (set for default ODR = 400 Hz, equivalent to 712 ms)

18.57 IMEM_SRAM_REG_293

Name: IMEM_SRAM_REG_293 Address: 293 (125h) Serial IF: R/W Reset value: Random value after reset until host runs EDMP_INIT procedure Clock Domain: MCLK		
BIT	NAME	FUNCTION
7:0	FF_MAX_DURATION[15:8]	Maximum freefall duration. Longer freefalls are ignored. Unit: time in samples number Range: [12 - 1040] Default: 285 (set for default ODR = 400 Hz, equivalent to 712 ms)

18.58 IMEM_SRAM_REG_294

Name: IMEM_SRAM_REG_294 Address: 294 (126h) Serial IF: R/W Reset value: Random value after reset until host runs EDMP_INIT procedure Clock Domain: MCLK		
BIT	NAME	FUNCTION
7:0	FF_MAX_DURATION[23:16]	Maximum freefall duration. Longer freefalls are ignored. Unit: time in samples number Range: [12 - 1040] Default: 285 (set for default ODR = 400 Hz, equivalent to 712 ms)

18.59 IMEM_SRAM_REG_295

Name: IMEM_SRAM_REG_295 Address: 295 (127h) Serial IF: R/W Reset value: Random value after reset until host runs EDMP_INIT procedure Clock Domain: MCLK		
BIT	NAME	FUNCTION
7:0	FF_MAX_DURATION[31:24]	Maximum freefall duration. Longer freefalls are ignored. Unit: time in samples number Range: [12 - 1040] Default: 285 (set for default ODR = 400 Hz, equivalent to 712 ms)

18.60 IMEM_SRAM_REG_296

Name: IMEM_SRAM_REG_296 Address: 296 (128h) Serial IF: R/W Reset value: Random value after reset until host runs EDMP_INIT procedure Clock Domain: MCLK		
BIT	NAME	FUNCTION
7:0	FF_DEBOUNCE_DURATION [7:0]	Period after a freefall is signaled during which a new freefall will not be detected. Prevents false detection due to bounces. Unit: time in samples number Range: [75 - 3000] Default: 800 (set for default ODR = 800 Hz, equivalent to 1 s)

18.61 IMEM_SRAM_REG_297

Name: IMEM_SRAM_REG_297 Address: 297 (129h) Serial IF: R/W Reset value: Random value after reset until host runs EDMP_INIT procedure Clock Domain: MCLK		
BIT	NAME	FUNCTION
7:0	FF_DEBOUNCE_DURATION [15:8]	Period after a freefall is signaled during which a new freefall will not be detected. Prevents false detection due to bounces. Unit: time in samples number Range: [75 - 3000] Default: 800 (set for default ODR = 800 Hz, equivalent to 1 s)

18.62 IMEM_SRAM_REG_298

Name: IMEM_SRAM_REG_298 Address: 298 (12Ah) Serial IF: R/W Reset value: Random value after reset until host runs EDMP_INIT procedure Clock Domain: MCLK		
BIT	NAME	FUNCTION
7:0	FF_DEBOUNCE_DURATION [23:16]	Period after a freefall is signaled during which a new freefall will not be detected. Prevents false detection due to bounces. Unit: time in samples number Range: [75 - 3000] Default: 800 (set for default ODR = 800 Hz, equivalent to 1 s)

18.63 IMEM_SRAM_REG_299

Name: IMEM_SRAM_REG_299 Address: 299 (12Bh) Serial IF: R/W Reset value: Random value after reset until host runs EDMP_INIT procedure Clock Domain: MCLK		
BIT	NAME	FUNCTION
7:0	FF_DEBOUNCE_DURATION [31:24]	Period after a freefall is signaled during which a new freefall will not be detected. Prevents false detection due to bounces. Unit: time in samples number Range: [75 - 3000] Default: 800 (set for default ODR = 800 Hz, equivalent to 1 s)

18.64 IMEM_SRAM_REG_304

Name: IMEM_SRAM_REG_304 Address: 304 (130h) Serial IF: R/W Reset value: Random value after reset until host runs EDMP_INIT procedure Clock Domain: MCLK		
BIT	NAME	FUNCTION
7:0	HIGHG_PEAK_TH[7:0]	Threshold for accel values above which high-g state is detected. Unit: g in q12 Range: [1024 - 32768] Default: 29696

18.65 IMEM_SRAM_REG_305

Name: IMEM_SRAM_REG_305 Address: 305 (131h) Serial IF: R/W Reset value: Random value after reset until host runs EDMP_INIT procedure Clock Domain: MCLK		
BIT	NAME	FUNCTION
7:0	HIGHG_PEAK_TH[15:8]	Threshold for accel values above which high-g state is detected. Unit: g in q12 Range: [1024 - 32768] Default: 29696

18.66 IMEM_SRAM_REG_306

Name: IMEM_SRAM_REG_306 Address: 306 (132h) Serial IF: R/W Reset value: Random value after reset until host runs EDMP_INIT procedure Clock Domain: MCLK		
BIT	NAME	FUNCTION
7:0	HIGHG_PEAK_TH_HYST[7:0]	Hysteresis value subtracted from the high-g threshold after exceeding it. Unit: g in q12 Range: [128 - 1024] Default: 640

18.67 IMEM_SRAM_REG_307

Name: IMEM_SRAM_REG_307 Address: 307 (133h) Serial IF: R/W Reset value: Random value after reset until host runs EDMP_INIT procedure Clock Domain: MCLK		
BIT	NAME	FUNCTION
7:0	HIGHG_PEAK_TH_HYST[15:8]	Hysteresis value subtracted from the high-g threshold after exceeding it. Unit: g in q12 Range: [128 - 1024] Default: 640

18.68 IMEM_SRAM_REG_308

Name: IMEM_SRAM_REG_308 Address: 308 (134h) Serial IF: R/W Reset value: Random value after reset until host runs EDMP_INIT procedure Clock Domain: MCLK		
BIT	NAME	FUNCTION
7:0	HIGHG_TIME_TH[7:0]	Threshold for accel values above which high-g state is detected. Unit: time in samples number Range: [1-300] Default: 1 (set for default ODR = 800 Hz, equivalent to 1.25 ms)

18.69 IMEM_SRAM_REG_309

Name: IMEM_SRAM_REG_309 Address: 309 (135h) Serial IF: R/W Reset value: Random value after reset until host runs EDMP_INIT procedure Clock Domain: MCLK		
BIT	NAME	FUNCTION
7:0	HIGHG_TIME_TH[15:8]	Threshold for accel values above which high-g state is detected. Unit: time in samples number Range: [1-300] Default: 1 (set for default ODR = 800 Hz, equivalent to 1.25 ms)

18.70 IMEM_SRAM_REG_316

Name: IMEM_SRAM_REG_316 Address: 316 (13Ch) Serial IF: R/W Reset value: Random value after reset until host runs EDMP_INIT procedure Clock Domain: MCLK		
BIT	NAME	FUNCTION
7:0	LOWG_PEAK_TH[7:0]	Threshold for accel values below which low-g state is detected. Unit: g in q12 Range: [128 - 4096] Default: 2048

18.71 IMEM_SRAM_REG_317

Name: IMEM_SRAM_REG_317 Address: 317 (13Dh) Serial IF: R/W Reset value: Random value after reset until host runs EDMP_INIT procedure Clock Domain: MCLK		
BIT	NAME	FUNCTION
7:0	LOWG_PEAK_TH[15:8]	Threshold for accel values below which low-g state is detected. Unit: g in q12 Range: [128 - 4096] Default: 2048

18.72 IMEM_SRAM_REG_318

Name: IMEM_SRAM_REG_318 Address: 318 (13Eh) Serial IF: R/W Reset value: Random value after reset until host runs EDMP_INIT procedure Clock Domain: MCLK		
BIT	NAME	FUNCTION
7:0	LOWG_PEAK_TH_HYST[7:0]	Hysteresis value added to the low-g threshold after exceeding it. Unit: g in q12 Range: [128 - 1024] Default: 128

18.73 IMEM_SRAM_REG_319

Name: IMEM_SRAM_REG_319 Address: 319 (13Fh) Serial IF: R/W Reset value: Random value after reset until host runs EDMP_INIT procedure Clock Domain: MCLK		
BIT	NAME	FUNCTION
7:0	LOWG_PEAK_TH_HYST[15:8]	Hysteresis value added to the low-g threshold after exceeding it. Unit: g in q12 Range: [128 - 1024] Default: 128

18.74 IMEM_SRAM_REG_320

Name: IMEM_SRAM_REG_320 Address: 320 (140h) Serial IF: R/W Reset value: Random value after reset until host runs EDMP_INIT procedure Clock Domain: MCLK		
BIT	NAME	FUNCTION
7:0	LOWG_TIME_TH[7:0]	Number of samples required to enter low-g state. Unit: time in samples number Range: [1 - 300] Default: 13 (set for default ODR = 800 Hz, equivalent to 16 ms)

18.75 IMEM_SRAM_REG_321

Name: IMEM_SRAM_REG_321 Address: 321 (141h) Serial IF: R/W Reset value: Random value after reset until host runs EDMP_INIT procedure Clock Domain: MCLK		
BIT	NAME	FUNCTION
7:0	LOWG_TIME_TH[15:8]	Number of samples required to enter low-g state. Unit: time in samples number Range: [1 - 300] Default: 13 (set for default ODR = 800 Hz, equivalent to 16 ms)

18.76 IMEM_SRAM_REG_392

Name: IMEM_SRAM_REG_392 Address: 392 (188h) Serial IF: R/W Reset value: Random value after reset until host runs EDMP_INIT procedure Clock Domain: MCLK		
BIT	NAME	FUNCTION
7:0	TILT_WAIT_TIME[7:0]	Minimum duration for which the device should be tilted before signaling event. Unit: time in sample number Range: [0 - 65536] Default: 200 for ODR = 50Hz, 100 for ODR = 25Hz

18.77 IMEM_SRAM_REG_393

Name: IMEM_SRAM_REG_393 Address: 393 (189h) Serial IF: R/W Reset value: Random value after reset until host runs EDMP_INIT procedure Clock Domain: MCLK		
BIT	NAME	FUNCTION
7:0	TILT_WAIT_TIME[15:8]	Minimum duration for which the device should be tilted before signaling event. Unit: time in sample number Range: [0 - 65536] Default: 200 for ODR = 50Hz, 100 for ODR = 25Hz

18.78 IMEM_SRAM_REG_400

Name: IMEM_SRAM_REG_400 Address: 400 (190h) Serial IF: R/W Reset value: Random value after reset until host runs EDMP_INIT procedure Clock Domain: MCLK		
BIT	NAME	FUNCTION
7:0	TAP_TMAX[7:0]	Size of the analysis window to detect tap events (single-tap or double-tap) unit: time in sample number range: [49 – 496] default: 99 (set for default ODR = 200Hz, equivalent to. 0.5s)

18.79 IMEM_SRAM_REG_401

Name: IMEM_SRAM_REG_401 Address: 401 (191h) Serial IF: R/W Reset value: Random value after reset until host runs EDMP_INIT procedure Clock Domain: MCLK		
BIT	NAME	FUNCTION
7:0	TAP_TMAX[15:8]	Size of the analysis window to detect tap events (single-tap or double-tap) unit: time in sample number range: [49 – 496] default: 99 (set for default ODR = 200Hz, equivalent to. 0.5s)

18.80 IMEM_SRAM_REG_402

Name: IMEM_SRAM_REG_402 Address: 402 (192h) Serial IF: R/W Reset value: Random value after reset until host runs EDMP_INIT procedure Clock Domain: MCLK		
BIT	NAME	FUNCTION
7:0	TAP_TMIN	Single tap window, sub-windows within Tmax to detect single-tap event. Unit: time in sample number Range: [24 – 184] Default: 33 (set for default ODR = 200Hz, equivalent to. 0.165s)

18.81 IMEM_SRAM_REG_403

Name: IMEM_SRAM_REG_403 Address: 403 (193h) Serial IF: R/W Reset value: Random value after reset until host runs EDMP_INIT procedure Clock Domain: MCLK		
BIT	NAME	FUNCTION
7:0	TAP_MIN_JERK	The minimal value of jerk to be considered as a tap candidate. Unit: g in q6 Range: [0 - 64] Default: 17

18.82 IMEM_SRAM_REG_404

Name: IMEM_SRAM_REG_404 Address: 404 (194h) Serial IF: R/W Reset value: Random value after reset until host runs EDMP_INIT procedure Clock Domain: MCLK		
BIT	NAME	FUNCTION
7:0	TAP_SMUDGE_REJECT_THR	Max acceptable number of samples (jerk value) over TAP_MAX_PEAK_TOL during the Tmin window. Over this value, Tap event is rejected unit: time in number of samples range: [13 – 92] Default: 17 (set for default ODR = 200Hz, equivalent to 0.085s)

18.83 IMEM_SRAM_REG_405

Name: IMEM_SRAM_REG_405 Address: 405 (195h) Serial IF: R/W Reset value: Random value after reset until host runs EDMP_INIT procedure Clock Domain: MCLK		
BIT	NAME	FUNCTION
7:0	TAP_MAX_PEAK_TOL	Maximum peak tolerance is the percentage of pulse amplitude to get the smudge threshold for rejection. Range: [1 (12.5%) 2 (25.0%) 3 (37.5%) 4 (50.0 %)] Default: 2 Default: 17

18.84 IMEM_SRAM_REG_406

Name: IMEM_SRAM_REG_406 Address: 406 (196h) Serial IF: R/W Reset value: Random value after reset until host runs EDMP_INIT procedure Clock Domain: MCLK		
BIT	NAME	FUNCTION
7:0	TAP_TAVG	Energy measurement window size to determine the tap axis associated with the 1st tap. Unit: time in sample number Range: [1 ; 2 ; 4 ; 8] Default: 8

18.85 IMEM_SRAM_REG_540

Name: IMEM_SRAM_REG_540 Address: 540 (21Ch) Serial IF: R/W Reset value: Random value after reset until host runs EDMP_INIT procedure Clock Domain: MCLK		
BIT	NAME	FUNCTION
7:0	R2W_SLEEP_TIME_OUT[7:0]	Defines the duration after wake event to report sleep event no matter if position changes or not. Unit: time in ms (millisecond) Range: [100 - 10000] Default: 640 (equivalent to 0.64s)

18.86 IMEM_SRAM_REG_541

Name: IMEM_SRAM_REG_541 Address: 541 (21Dh) Serial IF: R/W Reset value: Random value after reset until host runs EDMP_INIT procedure Clock Domain: MCLK		
BIT	NAME	FUNCTION
7:0	R2W_SLEEP_TIME_OUT[15:8]	Defines the duration after wake event to report sleep event no matter if position changes or not. Unit: time in ms (millisecond) Range: [100 - 10000] Default: 640 (equivalent to 0.64s)

18.87 IMEM_SRAM_REG_542

Name: IMEM_SRAM_REG_542 Address: 542 (21Eh) Serial IF: R/W Reset value: Random value after reset until host runs EDMP_INIT procedure Clock Domain: MCLK		
BIT	NAME	FUNCTION
7:0	R2W_SLEEP_TIME_OUT[23:16]	Defines the duration after wake event to report sleep event no matter if position changes or not. Unit: time in ms (millisecond) Range: [100 - 10000] Default: 640 (equivalent to 0.64s)

18.88 IMEM_SRAM_REG_543

Name: IMEM_SRAM_REG_543 Address: 543 (21Fh) Serial IF: R/W Reset value: Random value after reset until host runs EDMP_INIT procedure Clock Domain: MCLK		
BIT	NAME	FUNCTION
7:0	R2W_SLEEP_TIME_OUT[31:24]	Defines the duration after wake event to report sleep event no matter if position changes or not. Unit: time in ms (millisecond) Range: [100 - 10000] Default: 640 (equivalent to 0.64s)

18.89 IMEM_SRAM_REG_544

Name: IMEM_SRAM_REG_544 Address: 544 (220h) Serial IF: R/W Reset value: Random value after reset until host runs EDMP_INIT procedure Clock Domain: MCLK		
BIT	NAME	FUNCTION
7:0	R2W_SLEEP_GESTURE_DELETE[7:0]	Defines the minimal duration of sleep position before trigger the sleep event. Unit: time in ms (millisecond) Range: [0 - 256] Default: 96 (equivalent to 0.096s)

18.90 IMEM_SRAM_REG_545

Name: IMEM_SRAM_REG_545 Address: 545 (221h) Serial IF: R/W Reset value: Random value after reset until host runs EDMP_INIT procedure Clock Domain: MCLK		
BIT	NAME	FUNCTION
7:0	R2W_SLEEP_GESTURE_DELETE[15:8]	Defines the minimal duration of sleep position before trigger the sleep event. Unit: time in ms (millisecond) Range: [0 - 256] Default: 96 (equivalent to 0.096s)

18.91 IMEM_SRAM_REG_546

Name: IMEM_SRAM_REG_546 Address: 546 (222h) Serial IF: R/W Reset value: Random value after reset until host runs EDMP_INIT procedure Clock Domain: MCLK		
BIT	NAME	FUNCTION
7:0	R2W_SLEEP_GESTURE_DEL AY[23:16]	Defines the minimal duration of sleep position before trigger the sleep event. Unit: time in ms (millisecond) Range: [0 - 256] Default: 96 (equivalent to 0.096s)

18.92 IMEM_SRAM_REG_547

Name: IMEM_SRAM_REG_547 Address: 547 (223h) Serial IF: R/W Reset value: Random value after reset until host runs EDMP_INIT procedure Clock Domain: MCLK		
BIT	NAME	FUNCTION
7:0	R2W_SLEEP_GESTURE_DEL AY[31:24]	Defines the minimal duration of sleep position before trigger the sleep event. Unit: time in ms (millisecond) Range: [0 - 256] Default: 96 (equivalent to 0.096s)

18.93 IMEM_SRAM_REG_548

Name: IMEM_SRAM_REG_548 Address: 548 (224h) Serial IF: R/W Reset value: Random value after reset until host runs EDMP_INIT procedure Clock Domain: MCLK		
BIT	NAME	FUNCTION
7:0	R2W_MOUNTING_MATRIX [7:0]	Mounting matrix to rotate data from chip frame to device frame. Range: 3 lower bits only are used [b2 b1 b0]: <ul style="list-style-type: none"> - b2 = 1 swap X and Y - b1 = 1 flip X sign - b0 = 1 flip Y sign Default: 0 (device frame aligned with android frame)

18.94 IMEM_SRAM_REG_549

Name: IMEM_SRAM_REG_549 Address: 549 (225h) Serial IF: R/W Reset value: Random value after reset until host runs EDMP_INIT procedure Clock Domain: MCLK		
BIT	NAME	FUNCTION
7:0	R2W_MOUNTING_MATRIX [15:8]	Mounting matrix to rotate data from chip frame to device frame. Range: 3 lower bits only are used [b2 b1 b0]: - b2 = 1 swap X and Y - b1 = 1 flip X sign - b0 = 1 flip Y sign Default: 0 (device frame aligned with android frame)

18.95 IMEM_SRAM_REG_550

Name: IMEM_SRAM_REG_550 Address: 550 (226h) Serial IF: R/W Reset value: Random value after reset until host runs EDMP_INIT procedure Clock Domain: MCLK		
BIT	NAME	FUNCTION
7:0	R2W_MOUNTING_MATRIX [23:16]	Mounting matrix to rotate data from chip frame to device frame. Range: 3 lower bits only are used [b2 b1 b0]: - b2 = 1 swap X and Y - b1 = 1 flip X sign - b0 = 1 flip Y sign Default: 0 (device frame aligned with android frame)

18.96 IMEM_SRAM_REG_551

Name: IMEM_SRAM_REG_551 Address: 551 (227h) Serial IF: R/W Reset value: Random value after reset until host runs EDMP_INIT procedure Clock Domain: MCLK		
BIT	NAME	FUNCTION
7:0	R2W_MOUNTING_MATRIX [31:24]	Mounting matrix to rotate data from chip frame to device frame. Range: 3 lower bits only are used [b2 b1 b0]: - b2 = 1 swap X and Y - b1 = 1 flip X sign - b0 = 1 flip Y sign Default: 0 (device frame aligned with android frame)

18.97 IMEM_SRAM_REG_556

Name: IMEM_SRAM_REG_556 Address: 556 (22Ch) Serial IF: R/W Reset value: Random value after reset until host runs EDMP_INIT procedure Clock Domain: MCLK		
BIT	NAME	FUNCTION
7:0	R2W_GRAVITY_FILTER_GAIN[7:0]	Gain used to filter the accelerometer to obtain an estimation of the gravity (low-pass filter), defined as: forgetting factor = Gain * SAMPLING_PERIOD / (40 * 32), and 100Hz. Range: [2-16] Default: 6 for ODR = 50Hz, 8 for ODR = 25Hz

18.98 IMEM_SRAM_REG_557

Name: IMEM_SRAM_REG_557 Address: 557 (22Dh) Serial IF: R/W Reset value: Random value after reset until host runs EDMP_INIT procedure Clock Domain: MCLK		
BIT	NAME	FUNCTION
7:0	R2W_GRAVITY_FILTER_GAIN[15:8]	Gain used to filter the accelerometer to obtain an estimation of the gravity (low-pass filter), defined as: forgetting factor = Gain * SAMPLING_PERIOD / (40 * 32), and 100Hz. Range: [2-16] Default: 6 for ODR = 50Hz, 8 for ODR = 25Hz

18.99 IMEM_SRAM_REG_558

Name: IMEM_SRAM_REG_558 Address: 558 (22Eh) Serial IF: R/W Reset value: Random value after reset until host runs EDMP_INIT procedure Clock Domain: MCLK		
BIT	NAME	FUNCTION
7:0	R2W_GRAVITY_FILTER_GAIN[23:16]	Gain used to filter the accelerometer to obtain an estimation of the gravity (low-pass filter), defined as: forgetting factor = Gain * SAMPLING_PERIOD / (40 * 32), and 100Hz. Range: [2-16] Default: 6 for ODR = 50Hz, 8 for ODR = 25Hz

18.100 IMEM_SRAM_REG_559

Name: IMEM_SRAM_REG_559 Address: 559 (22Fh) Serial IF: R/W Reset value: Random value after reset until host runs EDMP_INIT procedure Clock Domain: MCLK		
BIT	NAME	FUNCTION
7:0	R2W_GRAVITY_FILTER_GAIN[31:24]	Gain used to filter the accelerometer to obtain an estimation of the gravity (low-pass filter), defined as: forgetting factor = Gain * SAMPLING_PERIOD / (40 * 32), and 100Hz. Range: [2-16] Default: 6 for ODR = 50Hz, 8 for ODR = 25Hz

18.101 IMEM_SRAM_REG_560

Name: IMEM_SRAM_REG_560 Address: 560 (230h) Serial IF: R/W Reset value: Random value after reset until host runs EDMP_INIT procedure Clock Domain: MCLK		
BIT	NAME	FUNCTION
7:0	R2W_MOTION_THR_ANGLE_COSINE[7:0]	Set the minimal angle that needed to be applied to device to detect R2W Unit: fixed point value q30 of cosine of the angle Range: [130856211 - 1069655912], corresponding to angle between 5 and 85 degrees Default: 1046221864, corresponding to an angle of 13 degrees

18.102 IMEM_SRAM_REG_561

Name: IMEM_SRAM_REG_561 Address: 561 (231h) Serial IF: R/W Reset value: Random value after reset until host runs EDMP_INIT procedure Clock Domain: MCLK		
BIT	NAME	FUNCTION
7:0	R2W_MOTION_THR_ANGLE_COSINE[15:8]	Set the minimal angle that needed to be applied to device to detect R2W Unit: fixed point value q30 of cosine of the angle Range: [130856211 - 1069655912], corresponding to angle between 5 and 85 degrees Default: 1046221864, corresponding to an angle of 13 degrees

18.103 IMEM_SRAM_REG_562

Name: IMEM_SRAM_REG_562 Address: 562 (232h) Serial IF: R/W Reset value: Random value after reset until host runs EDMP_INIT procedure Clock Domain: MCLK		
BIT	NAME	FUNCTION
7:0	R2W_MOTION_THR_ANGLE_COSINE[23:16]	Set the minimal angle that needed to be applied to device to detect R2W Unit: fixed point value q30 of cosine of the angle Range: [130856211 - 1069655912], corresponding to angle between 5 and 85 degrees Default: 1046221864, corresponding to an angle of 13 degrees

18.104 IMEM_SRAM_REG_563

Name: IMEM_SRAM_REG_563 Address: 563 (233h) Serial IF: R/W Reset value: Random value after reset until host runs EDMP_INIT procedure Clock Domain: MCLK		
BIT	NAME	FUNCTION
7:0	R2W_MOTION_THR_ANGLE_COSINE[31:24]	Set the minimal angle that needed to be applied to device to detect R2W Unit: fixed point value q30 of cosine of the angle Range: [130856211 - 1069655912], corresponding to angle between 5 and 85 degrees Default: 1046221864, corresponding to an angle of 13 degrees

18.105 IMEM_SRAM_REG_564

Name: IMEM_SRAM_REG_564 Address: 564 (234h) Serial IF: R/W Reset value: Random value after reset until host runs EDMP_INIT procedure Clock Domain: MCLK		
BIT	NAME	FUNCTION
7:0	R2W_MOTION_THR_TIMER_FAST[7:0]	Timer relative to the rapidity of the algorithm to trigger wake up when the orientation before motion is Y axis up (with less than 30 degrees of inclination). Unit: ms (no dependency on ODR, it is managed internally by the algorithm) Range: [100 - 500] Default: 240

18.106 IMEM_SRAM_REG_565

Name: IMEM_SRAM_REG_565 Address: 565 (235h) Serial IF: R/W Reset value: Random value after reset until host runs EDMP_INIT procedure Clock Domain: MCLK		
BIT	NAME	FUNCTION
7:0	R2W_MOTION_THR_TIME R_FAST[15:8]	Timer relative to the rapidity of the algorithm to trigger wake up when the orientation before motion is Y axis up (with less than 30 degrees of inclination). Unit: ms (no dependency on ODR, it is managed internally by the algorithm) Range: [100 - 500] Default: 240

18.107 IMEM_SRAM_REG_566

Name: IMEM_SRAM_REG_566 Address: 566 (236h) Serial IF: R/W Reset value: Random value after reset until host runs EDMP_INIT procedure Clock Domain: MCLK		
BIT	NAME	FUNCTION
7:0	R2W_MOTION_THR_TIME R_FAST[23:16]	Timer relative to the rapidity of the algorithm to trigger wake up when the orientation before motion is Y axis up (with less than 30 degrees of inclination). Unit: ms (no dependency on ODR, it is managed internally by the algorithm) Range: [100 - 500] Default: 240

18.108 IMEM_SRAM_REG_567

Name: IMEM_SRAM_REG_567 Address: 567 (237h) Serial IF: R/W Reset value: Random value after reset until host runs EDMP_INIT procedure Clock Domain: MCLK		
BIT	NAME	FUNCTION
7:0	R2W_MOTION_THR_TIME R_FAST[31:24]	Timer relative to the rapidity of the algorithm to trigger wake up when the orientation before motion is Y axis up (with less than 30 degrees of inclination). Unit: ms (no dependency on ODR, it is managed internally by the algorithm) Range: [100 - 500] Default: 240

18.109 IMEM_SRAM_REG_568

Name: IMEM_SRAM_REG_568 Address: 568 (238h) Serial IF: R/W Reset value: Random value after reset until host runs EDMP_INIT procedure Clock Domain: MCLK		
BIT	NAME	FUNCTION
7:0	R2W_MOTION_THR_TIME R_SLOW[7:0]	Timer relative to the rapidity of the algorithm to trigger wake up when the orientation before motion is Y axis up (with less than 30 degrees of inclination). Unit: ms (no dependency on ODR, it is managed internally by the algorithm) Range: [100 - 500] Default: 240

18.110 IMEM_SRAM_REG_569

Name: IMEM_SRAM_REG_569 Address: 569 (239h) Serial IF: R/W Reset value: Random value after reset until host runs EDMP_INIT procedure Clock Domain: MCLK		
BIT	NAME	FUNCTION
7:0	R2W_MOTION_THR_TIME R_SLOW[15:8]	Timer relative to the rapidity of the algorithm to trigger wake up when the orientation before motion is Y axis up (with less than 30 degrees of inclination). Unit: ms (no dependency on ODR, it is managed internally by the algorithm) Range: [100 - 500] Default: 240

18.111 IMEM_SRAM_REG_570

Name: IMEM_SRAM_REG_570 Address: 570 (23Ah) Serial IF: R/W Reset value: Random value after reset until host runs EDMP_INIT procedure Clock Domain: MCLK		
BIT	NAME	FUNCTION
7:0	R2W_MOTION_THR_TIME R_SLOW[23:16]	Timer relative to the rapidity of the algorithm to trigger wake up when the orientation before motion is Y axis up (with less than 30 degrees of inclination). Unit: ms (no dependency on ODR, it is managed internally by the algorithm) Range: [100 - 500] Default: 240

18.112 IMEM_SRAM_REG_571

Name: IMEM_SRAM_REG_571 Address: 571 (23Bh) Serial IF: R/W Reset value: Random value after reset until host runs EDMP_INIT procedure Clock Domain: MCLK		
BIT	NAME	FUNCTION
7:0	R2W_MOTION_THR_TIME R_SLOW[31:24]	Timer relative to the rapidity of the algorithm to trigger wake up when the orientation before motion is Y axis up (with less than 30 degrees of inclination). Unit: ms (no dependency on ODR, it is managed internally by the algorithm) Range: [100 - 500] Default: 240

18.113 IMEM_SRAM_REG_572

Name: IMEM_SRAM_REG_572 Address: 572 (23Ch) Serial IF: R/W Reset value: Random value after reset until host runs EDMP_INIT procedure Clock Domain: MCLK		
BIT	NAME	FUNCTION
7:0	R2W_MOTION_PREV_GRA VITY_TIMEOUT[7:0]	Time delay to update internal value of previous gravity when no motion is detected. Longer time enables detection motion during slower gesture. Unit: ms (no dependency on ODR, it is managed internally by the algorithm) Range: [100 - 1000] Default: 300

18.114 IMEM_SRAM_REG_573

Name: IMEM_SRAM_REG_573 Address: 573 (23Dh) Serial IF: R/W Reset value: Random value after reset until host runs EDMP_INIT procedure Clock Domain: MCLK		
BIT	NAME	FUNCTION
7:0	R2W_MOTION_PREV_GRA VITY_TIMEOUT[15:8]	Time delay to update internal value of previous gravity when no motion is detected. Longer time enables detection motion during slower gesture. Unit: ms (no dependency on ODR, it is managed internally by the algorithm) Range: [100 - 1000] Default: 300

18.115 IMEM_SRAM_REG_574

Name: IMEM_SRAM_REG_574 Address: 574 (23Eh) Serial IF: R/W Reset value: Random value after reset until host runs EDMP_INIT procedure Clock Domain: MCLK		
BIT	NAME	FUNCTION
7:0	R2W_MOTION_PREV_GRAVITY_TIMEOUT[23:16]	Time delay to update internal value of previous gravity when no motion is detected. Longer time enables detection motion during slower gesture. Unit: ms (no dependency on ODR, it is managed internally by the algorithm) Range: [100 - 1000] Default: 300

18.116 IMEM_SRAM_REG_575

Name: IMEM_SRAM_REG_575 Address: 575 (23Fh) Serial IF: R/W Reset value: Random value after reset until host runs EDMP_INIT procedure Clock Domain: MCLK		
BIT	NAME	FUNCTION
7:0	R2W_MOTION_PREV_GRAVITY_TIMEOUT[31:24]	Time delay to update internal value of previous gravity when no motion is detected. Longer time enables detection motion during slower gesture. Unit: ms (no dependency on ODR, it is managed internally by the algorithm) Range: [100 - 1000] Default: 300

18.117 IMEM_SRAM_REG_576

Name: IMEM_SRAM_REG_576 Address: 576 (240h) Serial IF: R/W Reset value: Random value after reset until host runs EDMP_INIT procedure Clock Domain: MCLK		
BIT	NAME	FUNCTION
7:0	R2W_LAST_GRAVITY_MOTION_TIMER[7:0]	Time delay to update the current gravity estimator when no motion is detected. Unit: ms (no dependency on ODR, it is managed internally by the algorithm) Range: [100 - 1000] Default: 480

18.118 IMEM_SRAM_REG_577

Name: IMEM_SRAM_REG_577 Address: 577 (241h) Serial IF: R/W Reset value: Random value after reset until host runs EDMP_INIT procedure Clock Domain: MCLK		
BIT	NAME	FUNCTION
7:0	R2W_LAST_GRAVITY_MOTION_TIMER[15:8]	Time delay to update the current gravity estimator when no motion is detected. Unit: ms (no dependency on ODR, it is managed internally by the algorithm) Range: [100 - 1000] Default: 480

18.119 IMEM_SRAM_REG_578

Name: IMEM_SRAM_REG_578 Address: 578 (242h) Serial IF: R/W Reset value: Random value after reset until host runs EDMP_INIT procedure Clock Domain: MCLK		
BIT	NAME	FUNCTION
7:0	R2W_LAST_GRAVITY_MOTION_TIMER[23:16]	Time delay to update the current gravity estimator when no motion is detected. Unit: ms (no dependency on ODR, it is managed internally by the algorithm) Range: [100 - 1000] Default: 480

18.120 IMEM_SRAM_REG_579

Name: IMEM_SRAM_REG_579 Address: 579 (243h) Serial IF: R/W Reset value: Random value after reset until host runs EDMP_INIT procedure Clock Domain: MCLK		
BIT	NAME	FUNCTION
7:0	R2W_LAST_GRAVITY_MOTION_TIMER[31:24]	Time delay to update the current gravity estimator when no motion is detected. Unit: ms (no dependency on ODR, it is managed internally by the algorithm) Range: [100 - 1000] Default: 480

18.121 IMEM_SRAM_REG_580

Name: IMEM_SRAM_REG_580 Address: 580 (244h) Serial IF: R/W Reset value: Random value after reset until host runs EDMP_INIT procedure Clock Domain: MCLK		
BIT	NAME	FUNCTION
7:0	R2W_LAST_GRAVITY_TIME_OUT[7:0]	Time delay to update gravity in case motion is detected all the time, force to update gravity estimator even if the device is not stable. Unit: ms (no dependency on ODR, it is managed internally by the algorithm) Range: [1000 - 10000] Default: 2600

18.122 IMEM_SRAM_REG_581

Name: IMEM_SRAM_REG_581 Address: 581 (245h) Serial IF: R/W Reset value: Random value after reset until host runs EDMP_INIT procedure Clock Domain: MCLK		
BIT	NAME	FUNCTION
7:0	R2W_LAST_GRAVITY_TIME_OUT[15:8]	Time delay to update gravity in case motion is detected all the time, force to update gravity estimator even if the device is not stable. Unit: ms (no dependency on ODR, it is managed internally by the algorithm) Range: [1000 - 10000] Default: 2600

18.123 IMEM_SRAM_REG_582

Name: IMEM_SRAM_REG_582 Address: 582 (246h) Serial IF: R/W Reset value: Random value after reset until host runs EDMP_INIT procedure Clock Domain: MCLK		
BIT	NAME	FUNCTION
7:0	R2W_LAST_GRAVITY_TIME_OUT[23:16]	Time delay to update gravity in case motion is detected all the time, force to update gravity estimator even if the device is not stable. Unit: ms (no dependency on ODR, it is managed internally by the algorithm) Range: [1000 - 10000] Default: 2600

18.124 IMEM_SRAM_REG_583

Name: IMEM_SRAM_REG_583 Address: 583 (247h) Serial IF: R/W Reset value: Random value after reset until host runs EDMP_INIT procedure Clock Domain: MCLK		
BIT	NAME	FUNCTION
7:0	R2W_LAST_GRAVITY_TIME_OUT[31:24]	Time delay to update gravity in case motion is detected all the time, force to update gravity estimator even if the device is not stable. Unit: ms (no dependency on ODR, it is managed internally by the algorithm) Range: [1000 - 10000] Default: 2600

18.125 IMEM_SRAM_REG_584

Name: IMEM_SRAM_REG_584 Address: 584 (248h) Serial IF: R/W Reset value: Random value after reset until host runs EDMP_INIT procedure Clock Domain: MCLK		
BIT	NAME	FUNCTION
7:0	R2W_GESTURE_VALIDITY_TIMEOUT[7:0]	If gesture is not completed in this timeout limit, gesture is invalid. Unit: ms (no dependency on ODR, it is managed internally by the algorithm) Range: [100 - 1000] Default: 240

18.126 IMEM_SRAM_REG_585

Name: IMEM_SRAM_REG_585 Address: 585 (249h) Serial IF: R/W Reset value: Random value after reset until host runs EDMP_INIT procedure Clock Domain: MCLK		
BIT	NAME	FUNCTION
7:0	R2W_GESTURE_VALIDITY_TIMEOUT[15:8]	If gesture is not completed in this timeout limit, gesture is invalid. Unit: ms (no dependency on ODR, it is managed internally by the algorithm) Range: [100 - 1000] Default: 240

18.127 IMEM_SRAM_REG_586

Name: IMEM_SRAM_REG_586 Address: 586 (24Ah) Serial IF: R/W Reset value: Random value after reset until host runs EDMP_INIT procedure Clock Domain: MCLK		
BIT	NAME	FUNCTION
7:0	R2W_GESTURE_VALIDITY_TIMEOUT[23:16]	If gesture is not completed in this timeout limit, gesture is invalid. Unit: ms (no dependency on ODR, it is managed internally by the algorithm) Range: [100 - 1000] Default: 240

18.128 IMEM_SRAM_REG_587

Name: IMEM_SRAM_REG_587 Address: 587 (24Bh) Serial IF: R/W Reset value: Random value after reset until host runs EDMP_INIT procedure Clock Domain: MCLK		
BIT	NAME	FUNCTION
7:0	R2W_GESTURE_VALIDITY_TIMEOUT[31:24]	If gesture is not completed in this timeout limit, gesture is invalid. Unit: ms (no dependency on ODR, it is managed internally by the algorithm) Range: [100 - 1000] Default: 240

18.129 IMEM_SRAM_REG_988

Name: IMEM_SRAM_REG_988 Address: 988 (3DCh) Serial IF: R/W Reset value: Random value after reset until host runs EDMP_INIT procedure Clock Domain: MCLK		
BIT	NAME	FUNCTION
7:0	PED_STEP_CNT_TH[7:0]	Minimum number of steps that must be detected before step count is incremented. Low values reduce latency but increase false positives. High values increase step count accuracy but increase latency Unit: Number of steps Range: [0-15] Default: 5

18.130 IMEM_SRAM_REG_989

Name: IMEM_SRAM_REG_989
 Address: 989 (3DDh)
 Serial IF: R/W
 Reset value: Random value after reset until host runs EDMP_INIT procedure
 Clock Domain: MCLK

BIT	NAME	FUNCTION
7:0	PED_STEP_CNT_TH[15:8]	Minimum number of steps that must be detected before step count is incremented. Low values reduce latency but increase false positives. High values increase step count accuracy but increase latency Unit: Number of steps Range: [0-15] Default: 5

18.131 IMEM_SRAM_REG_990

Name: IMEM_SRAM_REG_990
 Address: 990 (3DEh)
 Serial IF: R/W
 Reset value: Random value after reset until host runs EDMP_INIT procedure
 Clock Domain: MCLK

BIT	NAME	FUNCTION
7:0	PED_STEP_DET_TH[7:0]	Minimum number of steps that must be detected before step event is signaled. Low values reduce latency but increase false positives. High values increase step event validity but increase latency. Unit: number of steps Range: [0-7] Default: 2

18.132 IMEM_SRAM_REG_991

Name: IMEM_SRAM_REG_991
 Address: 991 (3DFh)
 Serial IF: R/W
 Reset value: Random value after reset until host runs EDMP_INIT procedure
 Clock Domain: MCLK

BIT	NAME	FUNCTION
7:0	PED_STEP_DET_TH[15:8]	Minimum number of steps that must be detected before step event is signaled. Low values reduce latency but increase false positives. High values increase step event validity but increase latency. Unit: number of steps Range: [0-7] Default: 2

18.133 IMEM_SRAM_REG_994

Name: IMEM_SRAM_REG_994 Address: 994 (3E2h) Serial IF: R/W Reset value: Random value after reset until host runs EDMP_INIT procedure Clock Domain: MCLK		
BIT	NAME	FUNCTION
7:0	PED_SB_TIMER_TH[7:0]	While in the step buffer state, the step buffer count resets to 0 if a new step isn't detected for this amount of time (user is considered to have "stopped walking"). Unit: time in samples number Range: [0 - 225] Default: 150 for ODR = 50Hz

18.134 IMEM_SRAM_REG_995

Name: IMEM_SRAM_REG_995 Address: 995 (3E3h) Serial IF: R/W Reset value: Random value after reset until host runs EDMP_INIT procedure Clock Domain: MCLK		
BIT	NAME	FUNCTION
7:0	PED_SB_TIMER_TH[15:8]	While in the step buffer state, the step buffer count resets to 0 if a new step isn't detected for this amount of time (user is considered to have "stopped walking"). Unit: time in samples number Range: [0 - 225] Default: 150 for ODR = 50Hz

18.135 IMEM_SRAM_REG_1000

Name: IMEM_SRAM_REG_1000 Address: 1000 (3E8h) Serial IF: R/W Reset value: Random value after reset until host runs EDMP_INIT procedure Clock Domain: MCLK		
BIT	NAME	FUNCTION
7:0	PED_LOW_EN_AMP_TH[7:0]	Threshold to select a valid step. Used to increase step detection for slow walk use case only. Unit: g in q25. Range: [1006632 - 3523215] Default: 2684354

18.136 IMEM_SRAM_REG_1001

Name: IMEM_SRAM_REG_1001
 Address: 1001 (3E9h)
 Serial IF: R/W
 Reset value: Random value after reset until host runs EDMP_INIT procedure
 Clock Domain: MCLK

BIT	NAME	FUNCTION
7:0	PED_LOW_EN_AMP_TH[15:8]	Threshold to select a valid step. Used to increase step detection for slow walk use case only. Unit: g in q25. Range: [1006632 - 3523215] Default: 2684354

18.137 IMEM_SRAM_REG_1002

Name: IMEM_SRAM_REG_1002
 Address: 1002 (3EAh)
 Serial IF: R/W
 Reset value: Random value after reset until host runs EDMP_INIT procedure
 Clock Domain: MCLK

BIT	NAME	FUNCTION
7:0	PED_LOW_EN_AMP_TH[23:16]	Threshold to select a valid step. Used to increase step detection for slow walk use case only. Unit: g in q25. Range: [1006632 - 3523215] Default: 2684354

18.138 IMEM_SRAM_REG_1003

Name: IMEM_SRAM_REG_1003
 Address: 1003 (3EBh)
 Serial IF: R/W
 Reset value: Random value after reset until host runs EDMP_INIT procedure
 Clock Domain: MCLK

BIT	NAME	FUNCTION
7:0	PED_LOW_EN_AMP_TH[31:24]	Threshold to select a valid step. Used to increase step detection for slow walk use case only. Unit: g in q25. Range: [1006632 - 3523215] Default: 2684354

18.139 IMEM_SRAM_REG_1004

Name: IMEM_SRAM_REG_1004
 Address: 1004 (3ECh)
 Serial IF: R/W
 Reset value: Random value after reset until host runs EDMP_INIT procedure
 Clock Domain: MCLK

BIT	NAME	FUNCTION
7:0	PED_SENSITIVITY_MODE	Pedometer sensitivity mode. Slow walk mode improves slow walk detection (<1 Hz) but the number of false positives may increase Range: 0: Normal 1: Slow walk Default: 0

18.140 IMEM_SRAM_REG_1008

Name: IMEM_SRAM_REG_1008
 Address: 1008 (3F0h)
 Serial IF: R/W
 Reset value: Random value after reset until host runs EDMP_INIT procedure
 Clock Domain: MCLK

BIT	NAME	FUNCTION
7:0	PED_AMP_TH[7:0]	Threshold of step detection sensitivity. Low values increase detection sensitivity: reduce miss-detection. High values reduce detection sensitivity: reduce false-positive. Unit: g in q25. Range: [1006632 - 3019898] Default: 2080374

18.141 IMEM_SRAM_REG_1009

Name: IMEM_SRAM_REG_1009
 Address: 1009 (3F1h)
 Serial IF: R/W
 Reset value: Random value after reset until host runs EDMP_INIT procedure
 Clock Domain: MCLK

BIT	NAME	FUNCTION
7:0	PED_AMP_TH[15:8]	Threshold of step detection sensitivity. Low values increase detection sensitivity: reduce miss-detection. High values reduce detection sensitivity: reduce false-positive. Unit: g in q25. Range: [1006632 - 3019898] Default: 2080374

18.142 IMEM_SRAM_REG_1010

Name: IMEM_SRAM_REG_1010 Address: 1010 (3F2h) Serial IF: R/W Reset value: Random value after reset until host runs EDMP_INIT procedure Clock Domain: MCLK		
BIT	NAME	FUNCTION
7:0	PED_AMP_TH[23:16]	Threshold of step detection sensitivity. Low values increase detection sensitivity: reduce miss-detection. High values reduce detection sensitivity: reduce false-positive. Unit: g in q25. Range: [1006632 - 3019898] Default: 2080374

18.143 IMEM_SRAM_REG_1011

Name: IMEM_SRAM_REG_1011 Address: 1011 (3F3h) Serial IF: R/W Reset value: Random value after reset until host runs EDMP_INIT procedure Clock Domain: MCLK		
BIT	NAME	FUNCTION
7:0	PED_AMP_TH[31:24]	Threshold of step detection sensitivity. Low values increase detection sensitivity: reduce miss-detection. High values reduce detection sensitivity: reduce false-positive. Unit: g in q25. Range: [1006632 - 3019898] Default: 2080374

18.144 IMEM_SRAM_REG_1016

Name: IMEM_SRAM_REG_1016 Address: 1016 (3F8h) Serial IF: R/W Reset value: Random value after reset until host runs EDMP_INIT procedure Clock Domain: MCLK		
BIT	NAME	FUNCTION
7:0	PED_HI_EN_TH[7:0]	Threshold to classify acceleration signal as motion not due to steps High values improve vibration rejection. Low values improve detection. Unit: g in q25. Range: [2949120 - 5210112] Default: 3506176

18.145 IMEM_SRAM_REG_1017

Name: IMEM_SRAM_REG_1017 Address: 1017 (3F9h) Serial IF: R/W Reset value: Random value after reset until host runs EDMP_INIT procedure Clock Domain: MCLK		
BIT	NAME	FUNCTION
7:0	PED_HI_EN_TH[15:8]	Threshold to classify acceleration signal as motion not due to steps High values improve vibration rejection. Low values improve detection. Unit: g in q25. Range: [2949120 - 5210112] Default: 3506176

18.146 IMEM_SRAM_REG_1018

Name: IMEM_SRAM_REG_1018 Address: 1018 (3FAh) Serial IF: R/W Reset value: Random value after reset until host runs EDMP_INIT procedure Clock Domain: MCLK		
BIT	NAME	FUNCTION
7:0	PED_HI_EN_TH[23:16]	Threshold to classify acceleration signal as motion not due to steps High values improve vibration rejection. Low values improve detection. Unit: g in q25. Range: [2949120 - 5210112] Default: 3506176

18.147 IMEM_SRAM_REG_1019

Name: IMEM_SRAM_REG_1019 Address: 1019 (3FBh) Serial IF: R/W Reset value: Random value after reset until host runs EDMP_INIT procedure Clock Domain: MCLK		
BIT	NAME	FUNCTION
7:0	PED_HI_EN_TH[31:24]	Threshold to classify acceleration signal as motion not due to steps High values improve vibration rejection. Low values improve detection. Unit: g in q25. Range: [2949120 - 5210112] Default: 3506176

18.148 IMEM_SRAM_REG_1042

Name: IMEM_SRAM_REG_1042
 Address: 1042 (412h)
 Serial IF: R/W
 Reset value: Random value after reset until host runs EDMP_INIT procedure
 Clock Domain: MCLK

BIT	NAME	FUNCTION
7:0	SMD_SENSITIVITY	Parameter to tune SMD algorithm robustness to rejection, ranging from 0 to 4 (values higher than 4 are reserved). Low values increase detection rate but increase false positives. High values reduce false positives but reduce detection rate (especially for transport use cases). Range: [0 - 4] Default: 0

18.149 IMEM_SRAM_REG_1168 TO IMEM_SRAM_REG_1203

Name: IMEM_SRAM_REG_1168 to IMEM_SRAM_REG_1203
 Address: 1168 to 1203 (490h to 4B3h)
 Serial IF: R/W
 Reset value: Random value after reset until host runs EDMP_INIT procedure
 Clock Domain: MCLK

BIT	NAME	FUNCTION
7:0	SOFT_IRON_SENSITIVITY_MATRIX[287:0]	Input 3x3 calibration matrix in q14 format applied to uncalibrated data.

19 USER BANK IPREG_BAR REGISTER MAP – DESCRIPTIONS

This section describes the function and contents of each register within user bank IPREG_BAR. The registers described in this section are indirect access registers. Section 13 describes the procedure for accessing indirect access registers.

19.1 IPREG_BAR_REG_57

Name: IPREG_BAR_REG_57		
Address: 57 (39h)		
Serial IF: R/W		
Reset value: 0x33		
Clock Domain: MCLK		
BIT	NAME	FUNCTION
7	-	Reserved
6	IO_OPT0	Set this register field to 1 for optimal speed of IOs. IO_OPT1 must be also set to 1 if IO_OPT0 is set to 1. Can be changed on-the-fly.
5	IO_OPT1	Set this register field to 1 for optimal speed of IOs. Can be changed on-the-fly.
4:0	-	Reserved

19.2 IPREG_BAR_REG_58

Name: IPREG_BAR_REG_58 Address: 58 (3Ah) Serial IF: R/W Reset value: 0xD9 Clock Domain: MCLK		
BIT	NAME	FUNCTION
7	PADS_AP_SCLK_PUD_TRIM_D2A	Selects internal resistor pull direction for AP_SCLK pin (pin 13) 0: Down 1: Up Can be changed on-the-fly.
6	PADS_AP_SCLK_PE_TRIM_D2A	Enables internal pull resistor to pull up or down for AP_SCLK pin (pin 13), depending on direction selected by bit 7. 0: Not enabled 1: Enabled Can be changed on-the-fly.
5	-	Reserved
4	PADS_AP_CS_PUD_TRIM_D2A	Selects internal resistor pull direction for AP_CS pin (pin 12) 0: Down 1: Up Can be changed on-the-fly.
3	PADS_AP_CS_PE_TRIM_D2A	Enables internal pull resistor to pull up or down for AP_CS pin (pin 12), depending on direction selected by bit 4. 0: Not enabled 1: Enabled Can be changed on-the-fly.
2:1	-	Reserved
0	IO_OPT2	Set this register field to 1 for optimal speed of IOs. IO_OPT1 must be also set to 1 if IO_OPT2 is set to 1 Can be changed on-the-fly.

19.3 IPREG_BAR_REG_59

Name: IPREG_BAR_REG_59 Address: 59 (3Bh) Serial IF: R/W Reset value: 0xB6 Clock Domain: MCLK		
BIT	NAME	FUNCTION
7	PADS_PIN7_PE_TRIM_D2A	Enables internal pull resistor to pull up or down for pin 7, depending on direction selected by bit 0 of register IPREG_BAR_REG_60 0: Not enabled 1: Enabled Can be changed on-the-fly.
6	-	Reserved
5	PADS_AP_SDO_PUD_TRIM_D2A	Selects internal resistor pull direction for AP_SDO pin (pin 1) 0: Down 1: Up Can be changed on-the-fly.
4	PADS_AP_SDO_PE_TRIM_D2A	Enables internal pull resistor to pull up or down for AP_SDO pin (pin 1), depending on direction selected by bit 5. 0: Not enabled 1: Enabled Can be changed on-the-fly.
3	-	Reserved
2	PADS_AP_SDI_PUD_TRIM_D2A	Selects internal resistor pull direction for AP_SDI pin (pin 14) 0: Down 1: Up Can be changed on-the-fly.
1	PADS_AP_SDI_PE_TRIM_D2A	Enables internal pull resistor to pull up or down for AP_SDI pin (pin 14), depending on direction selected by bit 2. 0: Not enabled 1: Enabled Can be changed on-the-fly.
0	-	Reserved

19.4 IPREG_BAR_REG_60

Name: IPREG_BAR_REG_60 Address: 60 (3Ch) Serial IF: R/W Reset value: 0x6D Clock Domain: MCLK		
BIT	NAME	FUNCTION
7	-	Reserved
6	PADS_AUX1_SCLK_PUD_TRIM_D2A	Enables internal pull resistor to pull up or down for AUX1_SCLK pin (pin 3), depending on direction selected by bit 5. 0: Not enabled 1: Enabled Can be changed on-the-fly.
5	PADS_AUX1_SCLK_PE_TRIM_D2A	Selects internal resistor pull direction for AUX1_SCLK pin (pin 3) 0: Down 1: Up Can be changed on-the-fly.
4	PADS_AUX_SCLK_TP2_FROM_PAD_DISABLE_TRIM_D2A	Set this bit to 1 if using I ² C master mode. Set it to 0 otherwise.
3	PADS_AUX1_CS_PUD_TRIM_D2A	Enables internal pull resistor to pull up or down for AUX1_CS pin (pin 10), depending on direction selected by bit 2. 0: Not enabled 1: Enabled Can be changed on-the-fly.
2	PADS_AUX1_CS_PE_TRIM_D2A	Selects internal resistor pull direction for AUX1_CS pin (pin 10) 0: Down 1: Up Can be changed on-the-fly.
1	-	Reserved
0	PADS_PIN7_CS_PUD_TRIM_D2A	Selects internal resistor pull direction for pin 7 0: Down 1: Up Can be changed on-the-fly.

19.5 IPREG_BAR_REG_61

Name: IPREG_BAR_REG_61 Address: 61 (3Dh) Serial IF: R/W Reset value: 0xBB Clock Domain: MCLK		
BIT	NAME	FUNCTION
7	PADS_INT1_PUD_TRIM_D2A	Enables internal pull resistor to pull up or down for INT1 pin (pin 4), depending on direction selected by bit 6. 0: Not enabled 1: Enabled Can be changed on-the-fly.
6	PADS_INT1_PE_TRIM_D2A	Selects internal resistor pull direction for INT1 pin (pin 4) 0: Down 1: Up Can be changed on-the-fly.
5	-	Reserved
4	PADS_AUX1_SDO_PUD_TRIM_D2A	Selects internal resistor pull direction for AUX1_SDO pin (pin 11) 0: Down 1: Up Can be changed on-the-fly.
3	PADS_AUX1_SDO_PE_TRIM_D2A	Enables internal pull resistor to pull up or down for AUX1_SDO pin (pin 11), depending on direction selected by bit 4. 0: Not enabled 1: Enabled Can be changed on-the-fly.
2	-	Reserved
1	PADS_AUX1_SDI_PUD_TRIM_D2A	Enables internal pull resistor to pull up or down for AUX1_SDI pin (pin 2), depending on direction selected by bit 0. 0: Not enabled 1: Enabled Can be changed on-the-fly.
0	PADS_AUX1_SDI_PE_TRIM_D2A	Selects internal resistor pull direction for AUX1_SDI pin (pin 2) 0: Down 1: Up Can be changed on-the-fly.

19.6 IPREG_BAR_REG_62

Name: IPREG_BAR_REG_62 Address: 62 (3Eh) Serial IF: R/W Reset value: 0x06 Clock Domain: MCLK		
BIT	NAME	FUNCTION
7:3	-	Reserved
2	PADS_INT2_PUD_TRIM_D2 A	Selects internal resistor pull direction for INT2 pin (pin 9) 0: Down 1: Up Can be changed on-the-fly.
1	PADS_INT2_PE_TRIM_D2A	Enables internal pull resistor to pull up or down for INT2 pin (pin 9), depending on direction selected by bit 2. 0: Not enabled 1: Enabled Can be changed on-the-fly.
0	-	Reserved

20 USER BANK IPREG_TOP1 REGISTER MAP – DESCRIPTIONS

This section describes the function and contents of each register within user bank IPREG_TOP1. The registers described in this section are indirect access registers. Section 13 describes the procedure for accessing indirect access registers.

20.1 I2CM_COMMAND_0

Name: I2CM_COMMAND_0 (I ² C master command buffer 0) Address: 06 (06h) Serial IF: R/W Reset value: 0x00 Clock Domain: MCLK		
BIT	NAME	FUNCTION
7	ENDFLAG_0	Indicates if the current entry is the last I ² C master communication with the external slave device.
6	CH_SEL_0	Specifies the channel number for I ² C master transaction. Two external sensors are supported. 0: Specify one external sensor with device ID "ID1" 1: Specify the other external sensor with device ID "ID2" "ID1" and "ID2" should be replaced by the actual device ID of the chosen external devices.
5:4	R_W_0	I ² C master read/write command. 00: Write operation 01: Read operation with register address specified 10: Read operation without register address specified 11: Reserved
3:0	BURSTLEN_0	Specifies the burst length of I ² C master communication with the external slave device. 0000: Reserved 0001: 1 byte 0010: 2 bytes 0011: 3 bytes 0100: 4 bytes 0101: 5 bytes 0110: 6 bytes 0111: 7 bytes 1000: 8 bytes 1001: 9 bytes 1010: 10 bytes 1011: 11 bytes 1100: 12 bytes 1101: 13 bytes 1110: 14 bytes 1111: 15 bytes Note: For write operation the valid values are 0001 to 0110; For read operation the valid values are 0001 to 1111.

20.2 I2CM_COMMAND_1

Name: I2CM_COMMAND_1 (I ² C master command buffer 1) Address: 07 (07h) Serial IF: R/W Reset value: 0x00 Clock Domain: MCLK		
BIT	NAME	FUNCTION
7	ENDFLAG_1	Indicates if the current entry is the last I ² C master communication with the external slave device.
6	CH_SEL_1	Specifies the channel number for I ² C master transaction. Two external sensors are supported. 0: Specify one external sensor with device ID "ID1" 1: Specify the other external sensor with device ID "ID2" "ID1" and "ID2" should be replaced by the actual device ID of the chosen external devices.
5:4	R_W_1	I ² C master read/write command. 00: Write operation 01: Read operation with register address specified 10: Read operation without register address specified 11: Reserved
3:0	BURSTLEN_1	Specifies the burst length of I ² C master communication with the external slave device. 0000: Reserved 0001: 1 byte 0010: 2 bytes 0011: 3 bytes 0100: 4 bytes 0101: 5 bytes 0110: 6 bytes 0111: 7 bytes 1000: 8 bytes 1001: 9 bytes 1010: 10 bytes 1011: 11 bytes 1100: 12 bytes 1101: 13 bytes 1110: 14 bytes 1111: 15 bytes Note: For write operation the valid values are 0001 to 0110; For read operation the valid values are 0001 to 1111.

20.3 I2CM_COMMAND_2

Name: I2CM_COMMAND_2 (I ² C master command buffer 2) Address: 08 (08h) Serial IF: R/W Reset value: 0x00 Clock Domain: MCLK		
BIT	NAME	FUNCTION
7	ENDFLAG_2	Indicates if the current entry is the last I ² C master communication with the external slave device.
6	CH_SEL_2	Specifies the channel number for I ² C master transaction. Two external sensors are supported. 0: Specify one external sensor with device ID "ID1" 1: Specify the other external sensor with device ID "ID2" "ID1" and "ID2" should be replaced by the actual device ID of the chosen external devices.
5:4	R_W_2	I ² C master read/write command. 00: Write operation 01: Read operation with register address specified 10: Read operation without register address specified 11: Reserved
3:0	BURSTLEN_2	Specifies the burst length of I ² C master communication with the external slave device. 0000: Reserved 0001: 1 byte 0010: 2 bytes 0011: 3 bytes 0100: 4 bytes 0101: 5 bytes 0110: 6 bytes 0111: 7 bytes 1000: 8 bytes 1001: 9 bytes 1010: 10 bytes 1011: 11 bytes 1100: 12 bytes 1101: 13 bytes 1110: 14 bytes 1111: 15 bytes Note: For write operation the valid values are 0001 to 0110; For read operation the valid values are 0001 to 1111.

20.4 I2CM_COMMAND_3

Name: I2CM_COMMAND_3 (I ² C master command buffer 3) Address: 09 (09h) Serial IF: R/W Reset value: 0x00 Clock Domain: MCLK		
BIT	NAME	FUNCTION
7	ENDFLAG_3	Indicates if the current entry is the last I ² C master communication with the external slave device.
6	CH_SEL_3	Specifies the channel number for I ² C master transaction. Two external sensors are supported. 0: Specify one external sensor with device ID "ID1" 1: Specify the other external sensor with device ID "ID2" "ID1" and "ID2" should be replaced by the actual device ID of the chosen external devices.
5:4	R_W_3	I ² C master read/write command. 00: Write operation 01: Read operation with register address specified 10: Read operation without register address specified 11: Reserved
3:0	BURSTLEN_3	Specifies the burst length of I ² C master communication with the external slave device. 0000: Reserved 0001: 1 byte 0010: 2 bytes 0011: 3 bytes 0100: 4 bytes 0101: 5 bytes 0110: 6 bytes 0111: 7 bytes 1000: 8 bytes 1001: 9 bytes 1010: 10 bytes 1011: 11 bytes 1100: 12 bytes 1101: 13 bytes 1110: 14 bytes 1111: 15 bytes Note: For write operation the valid values are 0001 to 0110; For read operation the valid values are 0001 to 1111.

20.5 I2CM_DEV_PROFILE0

Name: I2CM_DEV_PROFILE0		
Address: 14 (0Eh)		
Serial IF: R/W		
Reset value: 0x00		
Clock Domain: MCLK		
BIT	NAME	FUNCTION
7:0	RD_ADDRESS_0	Specifies the read address for channel 0 I ² C master transaction

20.6 I2CM_DEV_PROFILE1

Name: I2CM_DEV_PROFILE1		
Address: 15 (0Fh)		
Serial IF: R/W		
Reset value: 0x00		
Clock Domain: MCLK		
BIT	NAME	FUNCTION
7	-	Reserved
6:0	DEV_ID_0	Specifies the slave ID for channel 0 I ² C master transaction

20.7 I2CM_DEV_PROFILE2

Name: I2CM_DEV_PROFILE2		
Address: 16 (10h)		
Serial IF: R/W		
Reset value: 0x00		
Clock Domain: MCLK		
BIT	NAME	FUNCTION
7:0	RD_ADDRESS_1	Specifies the read address for channel 1 I ² C master transaction

20.8 I2CM_DEV_PROFILE3

Name: I2CM_DEV_PROFILE3		
Address: 17 (11h)		
Serial IF: R/W		
Reset value: 0x00		
Clock Domain: MCLK		
BIT	NAME	FUNCTION
7	-	Reserved
6:0	DEV_ID_1	Specifies the slave ID for channel 1 I ² C master transaction

20.9 I2CM_CONTROL

Name: I2CM_CONTROL Address: 22 (16h) Serial IF: RWS Reset value: 0x00 Clock Domain: MCLK		
BIT	NAME	FUNCTION
7	-	Reserved
6	I2CM_RESTART_EN	0: No Restart is used 1: In an I2C register read transaction, the Restart is used to bridge the register-address write transaction and register-data read transaction. This bit is not programmable by MCU when I2CM_BUSY = 1.
5:4	-	Reserved
3	I2CM_SPEED	0: I ² C Fast Mode 1: I ² C Standard Mode
2:1	-	Reserved
0	I2CM_GO	1: Kicks off I ² C master operation. Clears to 0 after I ² C master operation is completed. This bit is not programmable when I2CM_BUSY = 1

20.10 I2CM_STATUS

Name: I2CM_STATUS Address: 24 (18h) Serial IF: R Reset value: 0x00 Clock Domain: MCLK		
BIT	NAME	FUNCTION
7:6	-	Reserved
5	I2CM_SDA_ERR	I2C master SDA error indication
4	I2CM_SCL_ERR	I2C master SCL error indication
3	I2CM_SRST_ERR	I2C master SRST error indication
2	I2CM_TIMEOUT_ERR	I2C master timeout error indication
1	I2CM_DONE	1: Status bit, indicates I ² C master operation has completed, with or without errors. This bit is cleared due to (a) MCU read or (b) when I2CM_GO is programmed to 1 or (c) ODR event for fetching sensor data from the external sensor.
0	I2CM_BUSY	0: Indicates no I ² C master operation is running 1: Indicates I ² C master operation is running

20.11 I2CM_EXT_DEV_STATUS

Name: I2CM_EXT_DEV_STATUS Address: 26 (1Ah) Serial IF: R/C Reset value: 0x0F Clock Domain: MCLK		
BIT	NAME	FUNCTION
7:4	-	Reserved
3:0	I2CM_EXT_DEV_STATUS	<p>Indicates ACK/NACK feedback from the external device per each entry of the command buffer. I2CM_EXT_DEV_STATUS is set to 0xF whenever I²C master operation is kicked off.</p> <p>Bit 0 of I2CM_EXT_DEV_STATUS: ACK/NACK feedback from the external device to I2CM_COMMAND_0. 0: ACK 1: NACK</p> <p>Bit 1 of I2CM_EXT_DEV_STATUS: ACK/NACK feedback from the external device to I2CM_COMMAND_1. 0: ACK 1: NACK</p> <p>Bit 2 of I2CM_EXT_DEV_STATUS: ACK/NACK feedback from the external device to I2CM_COMMAND_2. 0: ACK 1: NACK</p> <p>Bit 3 of I2CM_EXT_DEV_STATUS: ACK/NACK feedback from the external device to I2CM_COMMAND_3. 0: ACK 1: NACK</p>

20.12 I2CM_RD_DATA0

Name: I2CM_RD_DATA0 Address: 27 (1Bh) Serial IF: RWS Reset value: 0x00 Clock Domain: MCLK		
BIT	NAME	FUNCTION
7:0	I2CM_RD_DATA0	<p>The 1st byte received from I²C slave.</p> <p>Content of this register is automatically cleared to 0 when I2CM_GO = 1 or upon ODR event for fetching sensor data from the external sensor.</p>

20.13 I2CM_RD_DATA1

Name: I2CM_RD_DATA1 Address: 28 (1Ch) Serial IF: RWS Reset value: 0x00 Clock Domain: MCLK		
BIT	NAME	FUNCTION
7:0	I2CM_RD_DATA1	The 2 nd byte received from I ² C slave. Content of this register is automatically cleared to 0 when I2CM_GO = 1 or upon ODR event for fetching sensor data from the external sensor.

20.14 I2CM_RD_DATA2

Name: I2CM_RD_DATA2 Address: 29 (1Dh) Serial IF: RWS Reset value: 0x00 Clock Domain: MCLK		
BIT	NAME	FUNCTION
7:0	I2CM_RD_DATA2	The 3 rd byte received from I ² C slave. Content of this register is automatically cleared to 0 when I2CM_GO = 1 or upon ODR event for fetching sensor data from the external sensor.

20.15 I2CM_RD_DATA3

Name: I2CM_RD_DATA3 Address: 30 (1Eh) Serial IF: RWS Reset value: 0x00 Clock Domain: MCLK		
BIT	NAME	FUNCTION
7:0	I2CM_RD_DATA3	The 4 th byte received from I ² C slave. Content of this register is automatically cleared to 0 when I2CM_GO = 1 or upon ODR event for fetching sensor data from the external sensor.

20.16 I2CM_RD_DATA4

Name: I2CM_RD_DATA4 Address: 31 (1Fh) Serial IF: RWS Reset value: 0x00 Clock Domain: MCLK		
BIT	NAME	FUNCTION
7:0	I2CM_RD_DATA4	The 5 th byte received from I ² C slave. Content of this register is automatically cleared to 0 when I2CM_GO = 1 or upon ODR event for fetching sensor data from the external sensor.

20.17 I2CM_RD_DATA5

Name: I2CM_RD_DATA5 Address: 32 (20h) Serial IF: RWS Reset value: 0x00 Clock Domain: MCLK		
BIT	NAME	FUNCTION
7:0	I2CM_RD_DATA5	The 6 th byte received from I ² C slave. Content of this register is automatically cleared to 0 when I2CM_GO = 1 or upon ODR event for fetching sensor data from the external sensor.

20.18 I2CM_RD_DATA6

Name: I2CM_RD_DATA6 Address: 33 (21h) Serial IF: RWS Reset value: 0x00 Clock Domain: MCLK		
BIT	NAME	FUNCTION
7:0	I2CM_RD_DATA6	The 7 th byte received from I ² C slave. Content of this register is automatically cleared to 0 when I2CM_GO = 1 or upon ODR event for fetching sensor data from the external sensor.

20.19 I2CM_RD_DATA7

Name: I2CM_RD_DATA7 Address: 34 (22h) Serial IF: RWS Reset value: 0x00 Clock Domain: MCLK		
BIT	NAME	FUNCTION
7:0	I2CM_RD_DATA7	The 8 th byte received from I ² C slave. Content of this register is automatically cleared to 0 when I2CM_GO = 1 or upon ODR event for fetching sensor data from the external sensor.

20.20 I2CM_RD_DATA8

Name: I2CM_RD_DATA8 Address: 35 (23h) Serial IF: RWS Reset value: 0x00 Clock Domain: MCLK		
BIT	NAME	FUNCTION
7:0	I2CM_RD_DATA8	The 9 th byte received from I ² C slave. Content of this register is automatically cleared to 0 when I2CM_GO = 1 or upon ODR event for fetching sensor data from the external sensor.

20.21 I2CM_RD_DATA9

Name: I2CM_RD_DATA9 Address: 36 (24h) Serial IF: RWS Reset value: 0x00 Clock Domain: MCLK		
BIT	NAME	FUNCTION
7:0	I2CM_RD_DATA9	The 10 th byte received from I ² C slave. Content of this register is automatically cleared to 0 when I2CM_GO = 1 or upon ODR event for fetching sensor data from the external sensor.

20.22 I2CM_RD_DATA10

Name: I2CM_RD_DATA10 Address: 37 (25h) Serial IF: RWS Reset value: 0x00 Clock Domain: MCLK		
BIT	NAME	FUNCTION
7:0	I2CM_RD_DATA10	The 11 th byte received from I ² C slave. Content of this register is automatically cleared to 0 when I2CM_GO = 1 or upon ODR event for fetching sensor data from the external sensor.

20.23 I2CM_RD_DATA11

Name: I2CM_RD_DATA11 Address: 38 (26h) Serial IF: RWS Reset value: 0x00 Clock Domain: MCLK		
BIT	NAME	FUNCTION
7:0	I2CM_RD_DATA11	The 12 th byte received from I ² C slave. Content of this register is automatically cleared to 0 when I2CM_GO = 1 or upon ODR event for fetching sensor data from the external sensor.

20.24 I2CM_RD_DATA12

Name: I2CM_RD_DATA12 Address: 39 (27h) Serial IF: RWS Reset value: 0x00 Clock Domain: MCLK		
BIT	NAME	FUNCTION
7:0	I2CM_RD_DATA12	The 13 th byte received from I ² C slave. Content of this register is automatically cleared to 0 when I2CM_GO = 1 or upon ODR event for fetching sensor data from the external sensor.

20.25 I2CM_RD_DATA13

Name: I2CM_RD_DATA13 Address: 40 (28h) Serial IF: RWS Reset value: 0x00 Clock Domain: MCLK		
BIT	NAME	FUNCTION
7:0	I2CM_RD_DATA13	The 14 th byte received from I ² C slave. Content of this register is automatically cleared to 0 when I2CM_GO = 1 or upon ODR event for fetching sensor data from the external sensor.

20.26 I2CM_RD_DATA14

Name: I2CM_RD_DATA14 Address: 41 (29h) Serial IF: RWS Reset value: 0x00 Clock Domain: MCLK		
BIT	NAME	FUNCTION
7:0	I2CM_RD_DATA14	The 15 th byte received from I ² C slave. Content of this register is automatically cleared to 0 when I2CM_GO = 1 or upon ODR event for fetching sensor data from the external sensor.

20.27 I2CM_RD_DATA15

Name: I2CM_RD_DATA15 Address: 42 (2Ah) Serial IF: RWS Reset value: 0x00 Clock Domain: MCLK		
BIT	NAME	FUNCTION
7:0	I2CM_RD_DATA15	The 16 th byte received from I ² C slave. Content of this register is automatically cleared to 0 when I2CM_GO = 1 or upon ODR event for fetching sensor data from the external sensor.

20.28 I2CM_RD_DATA16

Name: I2CM_RD_DATA16 Address: 43 (2Bh) Serial IF: RWS Reset value: 0x00 Clock Domain: MCLK		
BIT	NAME	FUNCTION
7:0	I2CM_RD_DATA16	The 17 th byte received from I ² C slave. Content of this register is automatically cleared to 0 when I2CM_GO = 1 or upon ODR event for fetching sensor data from the external sensor.

20.29 I2CM_RD_DATA17

Name: I2CM_RD_DATA17 Address: 44 (2Ch) Serial IF: RWS Reset value: 0x00 Clock Domain: MCLK		
BIT	NAME	FUNCTION
7:0	I2CM_RD_DATA17	The 18 th byte received from I ² C slave. Content of this register is automatically cleared to 0 when I2CM_GO = 1 or upon ODR event for fetching sensor data from the external sensor.

20.30 I2CM_RD_DATA18

Name: I2CM_RD_DATA18 Address: 45 (2Dh) Serial IF: RWS Reset value: 0x00 Clock Domain: MCLK		
BIT	NAME	FUNCTION
7:0	I2CM_RD_DATA18	The 19 th byte received from I ² C slave. Content of this register is automatically cleared to 0 when I2CM_GO = 1 or upon ODR event for fetching sensor data from the external sensor.

20.31 I2CM_RD_DATA19

Name: I2CM_RD_DATA19 Address: 46 (2Eh) Serial IF: RWS Reset value: 0x00 Clock Domain: MCLK		
BIT	NAME	FUNCTION
7:0	I2CM_RD_DATA19	The 20 th byte received from I ² C slave. Content of this register is automatically cleared to 0 when I2CM_GO = 1 or upon ODR event for fetching sensor data from the external sensor.

20.32 I2CM_RD_STATUS20

Name: I2CM_RD_DATA20 Address: 47 (2Fh) Serial IF: RWS Reset value: 0x00 Clock Domain: MCLK		
BIT	NAME	FUNCTION
7:0	I2CM_RD_DATA20	The 21 st byte received from I ² C slave. Content of this register is automatically cleared to 0 when I2CM_GO = 1 or upon ODR event for fetching sensor data from the external sensor.

20.33 I2CM_WR_DATA0

Name: I2CM_WR_DATA0 Address: 51 (33h) Serial IF: R/W Reset value: 0x00 Clock Domain: MCLK		
BIT	NAME	FUNCTION
7:0	I2CM_WR_DATA0	The data/address byte for a Write transaction.

20.34 I2CM_WR_DATA1

Name: I2CM_WR_DATA1 Address: 52 (34h) Serial IF: R/W Reset value: 0x00 Clock Domain: MCLK		
BIT	NAME	FUNCTION
7:0	I2CM_WR_DATA1	The data/address byte for a Write transaction.

20.35 I2CM_WR_DATA2

Name: I2CM_WR_DATA2		
Address: 53 (35h)		
Serial IF: R/W		
Reset value: 0x00		
Clock Domain: MCLK		
BIT	NAME	FUNCTION
7:0	I2CM_WR_DATA2	The data/address byte for a Write transaction.

20.36 I2CM_WR_DATA3

Name: I2CM_WR_DATA3		
Address: 54 (36h)		
Serial IF: R/W		
Reset value: 0x00		
Clock Domain: MCLK		
BIT	NAME	FUNCTION
7:0	I2CM_WR_DATA3	The data/address byte for a Write transaction.

20.37 I2CM_WR_DATA4

Name: I2CM_WR_DATA4		
Address: 55 (37h)		
Serial IF: R/W		
Reset value: 0x00		
Clock Domain: MCLK		
BIT	NAME	FUNCTION
7:0	I2CM_WR_DATA4	The data/address byte for a Write transaction.

20.38 I2CM_WR_DATA5

Name: I2CM_WR_DATA5		
Address: 56 (38h)		
Serial IF: R/W		
Reset value: 0x00		
Clock Domain: MCLK		
BIT	NAME	FUNCTION
7:0	I2CM_WR_DATA5	The data/address byte for a Write transaction.

20.39 SIFS_IXC_ERROR_STATUS

Name: SIFS_IXC_ERROR_STATUS Address: 75 (4Bh) Serial IF: R/C Reset value: 0x00 Clock Domain: MCLK		
BIT	NAME	FUNCTION
7:2	-	Reserved
1	AUX1_SIFS_IXC_TIMEOUT_ERR	0: No timeout error. 1: Indicates than an lxC timeout error occurred in AUX1 SIFS. No clock toggle condition from host for 32ms while an lxC transaction was ongoing (after START and before STOP).
0	SIFS_IXC_TIMEOUT_ERR	0: No timeout error or when SPI slave is selected for serial transfers. 1: Indicates than an lxC timeout error occurred in SIFS. No clock toggle condition from host for 32ms while an lxC transaction was ongoing (after START and before STOP).

20.40 EDMP_PRGRM_IRQ0_0

Name: EDMP_PRGRM_IRQ0_0 Address: 79 (4Fh) Serial IF: R/W Reset value: 0x00 Clock Domain: MCLK		
BIT	NAME	FUNCTION
7:0	PRGRM_STRT_ADDR_IRQ_0[7:0]	Start address of IRQ_0 vector. Can be changed on-the-fly.

20.41 EDMP_PRGRM_IRQ0_1

Name: EDMP_PRGRM_IRQ0_1 Address: 80 (50h) Serial IF: R/W Reset value: 0x00 Clock Domain: MCLK		
BIT	NAME	FUNCTION
7:0	PRGRM_STRT_ADDR_IRQ_0[15:8]	Start address of IRQ_0 vector. Can be changed on-the-fly.

20.42 EDMP_PRGRM_IRQ1_0

Name: EDMP_PRGRM_IRQ1_0 Address: 81 (51h) Serial IF: R/W Reset value: 0x00 Clock Domain: MCLK		
BIT	NAME	FUNCTION
7:0	PRGRM_STRT_ADDR_IRQ_1[7:0]	Start address of IRQ_1 vector. Can be changed on-the-fly.

20.43 EDMP_PRGRM_IRQ1_1

Name: EDMP_PRGRM_IRQ1_1 Address: 82 (52h) Serial IF: R/W Reset value: 0x00 Clock Domain: MCLK		
BIT	NAME	FUNCTION
7:0	PRGRM_STRT_ADDR_IRQ_1[15:8]	Start address of IRQ_1 vector. Can be changed on-the-fly.

20.44 EDMP_PRGRM_IRQ2_0

Name: EDMP_PRGRM_IRQ2_0 Address: 83 (53h) Serial IF: R/W Reset value: 0x00 Clock Domain: MCLK		
BIT	NAME	FUNCTION
7:0	PRGRM_STRT_ADDR_IRQ_2[7:0]	Start address of IRQ_2 vector. Can be changed on-the-fly.

20.45 EDMP_PRGRM_IRQ2_1

Name: EDMP_PRGRM_IRQ2_1 Address: 84 (54h) Serial IF: R/W Reset value: 0x00 Clock Domain: MCLK		
BIT	NAME	FUNCTION
7:0	PRGRM_STRT_ADDR_IRQ_2[15:8]	Start address of IRQ_2 vector. Can be changed on-the-fly.

20.46 EDMP_SP_START_ADDR

Name: EDMP_SP_START_ADDR Address: 85 (55h) Serial IF: R/W Reset value: 0x00 Clock Domain: MCLK		
BIT	NAME	FUNCTION
7:0	EDMP_SP_START_ADDR	Sets eDMP stack address. Can be changed on-the-fly.

20.47 SMC_CONTROL_0

Name: SMC_CONTROL_0 Address: 88 (58h) Serial IF: R/W Reset value: 0x60 Clock Domain: MCLK		
BIT	NAME	FUNCTION
7:5	-	Reserved
4	ACCEL_LP_CLK_SEL	<p>This bit is applicable to host interface operation.</p> <p>A. When RTC mode is not enabled (or RTC_MODE = 0):</p> <p>This bit is effective when the host interface is in accel only operation with ACCEL_MODE set to LP mode.</p> <p>0: Host interface is in AULP mode. 1: Host interface is in ALP mode.</p> <p>When I3CSM Synchronous Timing Control function is enabled on host interface, if the host interface is in accel only operation with ACCEL_MODE set to LP mode, ACCEL_LP_CLK_SEL must be set to 1. I3CSM Synchronous Timing Control may not generate correct timing if ACCEL_LP_CLK_SEL is set to 0.</p> <p>B. When RTC mode is enabled (or RTC_MODE = 1):</p> <p>Independent of enabling/disabling of I3CSM Synchronous timing control function, ACCEL_LP_CLK_SEL must be set to 1.</p> <p>Dynamic Change Supported.</p>
3	TEMP_DIS	<p>0: Temperature Sensor not disabled. 1: Temperature Sensor disabled.</p>
2	TMST_FORCE_AUX_FINE_EN	<p>0: Time Stamp fine counting enabled only on UI interface. 1: Time Stamp fine counting enabled on AUX interfaces in addition to UI interface.</p>
1	TMST_FSYNC_EN	<p>Time Stamp register FSYNC Enable.</p> <p>0: Timestamp feature of FSYNC not enabled.</p>

		1: Timestamp feature of FSYNC enabled.
0	TMST_EN	0: Timestamp not enabled. 1: Timestamp enabled.

20.48 SMC_CONTROL_1

Name: SMC_CONTROL_1 Address: 89 (59h) Serial IF: R/W Reset value: 0x04 Clock Domain: MCLK		
BIT	NAME	FUNCTION
7:4	-	Reserved
3	SREG_AUX_ACCEL_ONLY_EN	0: Sensor data register read from AUX1 interface is supported only if gyro sensor is enabled. 1: Sensor data register read from AUX1 interface is supported even if gyro sensor is not enabled.
2:0	-	Reserved

20.49 STC_CONFIG

Name: STC_CONFIG Address: 99 (63h) Serial IF: R/W Reset value: 0x00 Clock Domain: MCLK		
BIT	NAME	FUNCTION
7:4	-	Reserved
3:2	STC_SENSOR_SEL	Sensor that controls STC: 0 or 1: Slowest ODR sensor 2: Accel 3: Gyro
1:0	-	Reserved

20.50 SREG_CTRL

Name: SREG_CTRL Address: 103 (67h) Serial IF: R/W Reset value: 0x00 Clock Domain: MCLK		
BIT	NAME	FUNCTION
7:2	-	Reserved
1	SREG_DATA_ENDIAN_SEL	Selects Endianness of Sensor Data Registers and FIFO data 0: Sensor data, FIFO data, and FIFO count is in Little Endian format 1: Sensor data, FIFO data, and FIFO count is in Big Endian format Note: User must set register field SREG_DATA_ENDIAN_SEL to 1, to enable Big Endian data format for data in Sensor Data Registers and FIFO, and for FIFO Count.
0	-	Reserved

20.51 SIFS_I3C_STC_CFG

Name: SIFS_I3C_STC_CFG Address: 104 (68h) Serial IF: R/W Reset value: 0x23 Clock Domain: MCLK		
BIT	NAME	FUNCTION
7:3	-	Reserved
2	I3C_STC_MODE	Enable the STC controller 0: Disable I3C STC. 1: Enable I3C STC. Toggling this bit restarts the ODR frequency and phase correction operation as if the chip is out of reset. The STC functionality can be enabled only if ACCEL_LP_CLK_SEL is set to 1; otherwise device may not behave as expected.
1:0	-	Reserved

20.52 INT_PULSE_MIN_ON_INTF0

Name: INT_PULSE_MIN_ON_INTF0 Address: 105 (69h) Serial IF: R/W Reset value: 0x01 Clock Domain: MCLK		
BIT	NAME	FUNCTION
7:3	-	Reserved
2:0	INT0_TPULSE_DURATION	INT0 interrupt pulse minimum “on” duration for host interface, when in pulse mode. 0: 100µs (use only if ODR < 4kHz) 1: 8µs (required if ODR ≥ 4kHz, optional for ODR < 4kHz) Other Settings: Reserved

20.53 INT_PULSE_MIN_ON_INTF1

Name: INT_PULSE_MIN_ON_INTF1 Address: 106 (6Ah) Serial IF: R/W Reset value: 0x01 Clock Domain: MCLK		
BIT	NAME	FUNCTION
7:3	-	Reserved
2:0	INT1_TPULSE_DURATION	INT1 interrupt pulse minimum “on” duration for host interface, when in pulse mode. 0: 100µs (use only if ODR < 4kHz) 1: 8µs (required if ODR ≥ 4kHz, optional for ODR < 4kHz) Other Settings: Reserved

20.54 INT_PULSE_MIN_OFF_INTF0

Name: INT_PULSE_MIN_OFF_INTF0 Address: 107 (6Bh) Serial IF: R/W Reset value: 0x01 Clock Domain: MCLK		
BIT	NAME	FUNCTION
7:3	-	Reserved
2:0	INT0_TDEASSERT_DISABLE	INT0 interrupt pulse minimum “off” duration for host interface, indicates minimum interrupt de-assertion duration. 0: 100µs 1: 8µs Other Settings: Reserved

20.55 INT_PULSE_MIN_OFF_INTF1

Name: INT_PULSE_MIN_OFF_INTF1 Address: 108 (6Ch) Serial IF: R/W Reset value: 0x01 Clock Domain: MCLK		
BIT	NAME	FUNCTION
7:3	-	Reserved
2:0	INT1_TDEASSERT_DISABLE	INT1 interrupt pulse minimum "off" duration for host interface, indicates minimum interrupt de-assertion duration. 0: 100µs 1: 8µs Other Settings: Reserved

20.56 ISR_0_7

Name: ISR_0_7 Address: 110 (6Eh) Serial IF: R/C Reset value: 0x00 Clock Domain: MCLK		
BIT	NAME	FUNCTION
7:6	-	Reserved
5	INT_STATUS_ON_DEMAND_PIN_0	For IRQ0 interface, if this interrupt status bit is enabled, this bit is to flag the occurrence of on demand event. 0: Interrupt did not occur. 1: Interrupt occurred.
4	-	Reserved
3	INT_STATUS_EXT_ODR_DRDY_PIN_0	For IRQ0 interface, if this interrupt status bit is enabled, this bit is to flag the occurrence of EXT ODR DRDY event. 0: Interrupt did not occur. 1: Interrupt occurred.
2:1	-	Reserved
0	INT_STATUS_ACCEL_DRDY_PIN_0	For IRQ0 interface, if this interrupt status bit is enabled, this bit is to flag the occurrence of Accel DRDY event. 0: Interrupt did not occur. 1: Interrupt occurred.

20.57 ISR_8_15

Name: ISR_8_15 Address: 111 (6Fh) Serial IF: R/C Reset value: 0x00 Clock Domain: MCLK		
BIT	NAME	FUNCTION
7:6	-	Reserved
5	INT_STATUS_ON_DEMAND_PIN_1	For IRQ1 interface, if this interrupt status bit is enabled, this bit is to flag the occurrence of on demand event. 0: Interrupt did not occur. 1: Interrupt occurred.
4	-	Reserved
3	INT_STATUS_EXT_ODR_DRDY_PIN_1	For IRQ1 interface, if this interrupt status bit is enabled, this bit is to flag the occurrence of EXT ODR DRDY event. 0: Interrupt did not occur. 1: Interrupt occurred.
2:1	-	Reserved
0	INT_STATUS_ACCEL_DRDY_PIN_1	For IRQ1 interface, if this interrupt status bit is enabled, this bit is to flag the occurrence of Accel DRDY event. 0: Interrupt did not occur. 1: Interrupt occurred.

20.58 ISR_16_23

Name: ISR_16_23 Address: 112 (70h) Serial IF: R/C Reset value: 0x00 Clock Domain: MCLK		
BIT	NAME	FUNCTION
7:6	-	Reserved
5	INT_STATUS_ON_DEMAND_PIN_2	For IRQ2 interface, if this interrupt status bit is enabled, this bit is to flag the occurrence of on demand event. 0: Interrupt did not occur. 1: Interrupt occurred.
4	-	Reserved
3	INT_STATUS_EXT_ODR_DRDY_PIN_2	For IRQ2 interface, if this interrupt status bit is enabled, this bit is to flag the occurrence of EXT ODR DRDY event. 0: Interrupt did not occur. 1: Interrupt occurred.
2:1	-	Reserved
0	INT_STATUS_ACCEL_DRDY_PIN_2	For IRQ2 interface, if this interrupt status bit is enabled, this bit is to flag the occurrence of Accel DRDY event. 0: Interrupt did not occur.

	1: Interrupt occurred.
--	------------------------

20.59 STATUS_MASK_PIN_0_7

Name: STATUS_MASK_PIN_0_7 Address: 113 (71h) Serial IF: R/W Reset value: 0x3F Clock Domain: MCLK		
BIT	NAME	FUNCTION
7:6	-	Reserved
5	INT_ON_DEMAND_PIN_0_DIS	For IRQ0, on-demand DRDY event, this is to enable the interrupt pin assertion when the INT_STATUS_ON_DEMAND_PIN_0 status bit is 1. 0: Enable the Interrupt pin assertion. 1: No Interrupt pin assertion.
4	-	Reserved
3	INT_EXT_ODR_DRDY_PIN_0_DIS	For IRQ0, ODR DRDY event, this is to enable the interrupt pin assertion when the INT_STATUS_EXT_ODR_DRDY_PIN_0 status bit is 1. 0: Enable the Interrupt pin assertion. 1: No Interrupt pin assertion.
2:1	-	Reserved
0	INT_ACCEL_DRDY_PIN_0_DIS	For IRQ0, accel DRDY event, this is to enable the interrupt pin assertion when the INT_STATUS_ACCEL_DRDY_PIN_0 status bit is 1. 0: Enable the Interrupt pin assertion. 1: No Interrupt pin assertion.

20.60 STATUS_MASK_PIN_8_15

Name: STATUS_MASK_PIN_8_15 Address: 114 (72h) Serial IF: R/W Reset value: 0x3F Clock Domain: MCLK		
BIT	NAME	FUNCTION
7:6	-	Reserved
5	INT_ON_DEMAND_PIN_1_DIS	For IRQ1, on-demand DRDY event, this is to enable the interrupt pin assertion when the INT_STATUS_ON_DEMAND_PIN_1 status bit is 1. 0: Enable the Interrupt pin assertion. 1: No Interrupt pin assertion.
4	-	Reserved
3	INT_EXT_ODR_DRDY_PIN_1_DIS	For IRQ1, ODR DRDY event, this is to enable the interrupt pin assertion when the INT_STATUS_EXT_ODR_DRDY_PIN_1 status bit is 1. 0: Enable the Interrupt pin assertion. 1: No Interrupt pin assertion.
2:1	-	Reserved
0	INT_ACCEL_DRDY_PIN_1_DIS	For IRQ1, accel DRDY event, this is to enable the interrupt pin assertion when the INT_STATUS_ACCEL_DRDY_PIN_1 status bit is 1. 0: Enable the Interrupt pin assertion. 1: No Interrupt pin assertion.

20.61 STATUS_MASK_PIN_16_23

Name: STATUS_MASK_PIN_16_23 Address: 115 (73h) Serial IF: R/W Reset value: 0x3F Clock Domain: MCLK		
BIT	NAME	FUNCTION
7:6	-	Reserved
5	INT_ON_DEMAND_PIN_2_DIS	Enables the eDMP to be run once when IRQ2 is triggered by setting the EDMP_ON_DEMAND_EN bit.
4	-	Reserved
3	INT_EXT_ODR_DRDY_PIN_2_DIS	For IRQ2, ODR DRDY event, this is to enable the interrupt pin assertion when the INT_STATUS_EXT_ODR_DRDY_PIN_2 status bit is 1. 0: Enable the Interrupt pin assertion. 1: No Interrupt pin assertion.
2:1	-	Reserved
0	INT_ACCEL_DRDY_PIN_2_DIS	For IRQ2, accel DRDY event, this is to enable the interrupt pin assertion when the INT_STATUS_ACCEL_DRDY_PIN_2 status bit is 1. 0: Enable the Interrupt pin assertion. 1: No Interrupt pin assertion.

20.62 INT_I2CM_SOURCE

Name: INT_I2CM_SOURCE Address: 116 (74h) Serial IF: R/W Reset value: 0x00 Clock Domain: MCLK		
BIT	NAME	FUNCTION
7:2	-	Reserved
1	INT_STATUS_I2CM_SMC_EXT_ODR_EN	0: Does not automatically trigger eDMP operation on target ODR 1: Automatically triggers eDMP operation on target ODR
0	-	Reserved

20.63 ACCEL_WOM_X_THR

Name: ACCEL_WOM_X_THR Address: 126 (7Eh) Serial IF: R/W Reset value: 0x00 Clock Domain: MCLK		
BIT	NAME	FUNCTION
7:0	WOM_X_TH	Set X-axis Wake on Motion threshold Wake on Motion thresholds are expressed in fixed “mg” independently of the selected full-scale (format <U,8,0>, range [0g : 1g], resolution 1g/256≈4mg)

20.64 ACCEL_WOM_Y_THR

Name: ACCEL_WOM_Y_THR Address: 127 (7Fh) Serial IF: R/W Reset value: 0x00 Clock Domain: MCLK		
BIT	NAME	FUNCTION
7:0	WOM_Y_TH	Set Y-axis Wake on Motion threshold Wake on Motion thresholds are expressed in fixed “mg” independently of the selected full-scale (format <U,8,0>, range [0g : 1g], resolution 1g/256=~4mg)

20.65 ACCEL_WOM_Z_THR

Name: ACCEL_WOM_Z_THR Address: 128 (80h) Serial IF: R/W Reset value: 0x00 Clock Domain: MCLK		
BIT	NAME	FUNCTION
7:0	WOM_Z_TH	Set Z-axis Wake on Motion threshold Wake on Motion thresholds are expressed in fixed “mg” independently of the selected full-scale (format <U,8,0>, range [0g : 1g], resolution 1g/256=~4mg)

20.66 SELFTEST

Name: SELFTEST Address: 144 (90h) Serial IF: R/W Reset value: 0x00 Clock Domain: MCLK		
BIT	NAME	FUNCTION
7:6	-	Reserved
5	EN_GZ_ST	0: Z-axis gyroscope self-test is not enabled 1: Z-axis gyroscope self-test is enabled Can be changed on-the-fly.
4	EN_GY_ST	0: Y-axis gyroscope self-test is not enabled 1: Y-axis gyroscope self-test is enabled Can be changed on-the-fly.
3	EN_GX_ST	0: X-axis gyroscope self-test is not enabled 1: X-axis gyroscope self-test is enabled Can be changed on-the-fly.
2	EN_AZ_ST	0: Z-axis accelerometer self-test is not enabled 1: Z-axis accelerometer self-test is enabled Can be changed on-the-fly.
1	EN_AY_ST	0: Y-axis accelerometer self-test is not enabled 1: Y-axis accelerometer self-test is enabled Can be changed on-the-fly.
0	EN_AX_ST	0: X-axis accelerometer self-test is not enabled 1: X-axis accelerometer self-test is enabled Can be changed on-the-fly.

20.67 IPREG_MISC

Name: IPREG_MISC Address: 151 (97h) Serial IF: R Reset value: 0x02 Clock Domain: MCLK		
BIT	NAME	FUNCTION
7:2	-	Reserved
1	EDMP_IDLE	0: Indicates eDMP is busy. 1: Indicates eDMP is idle.
0	-	Reserved

20.68 SW_PLL1_TRIM

Name: SW_PLL1_TRIM Address: 162 (A2h) Serial IF: R Reset value: 0x00 Clock Domain: MCLK		
BIT	NAME	FUNCTION
7:0	SW_PLL1_TRIM	Stores variation of PLL frequency test measurement vs. target value, used for SW applications. Value to trim = $(PLL_measurement - 6144000Hz) / 6144000Hz * 2540$. 6144000Hz is the target PLL freq. 2540 is the resolution coefficient: max register range / max oscillator frequency error = $(2^7 - 1) / 5\%$, with a sign bit.

20.69 FIFO_SRAM_SLEEP

Name: FIFO_SRAM_SLEEP Address: 167 (A7h) Serial IF: R/W Reset value: 0x00 Clock Domain: MCLK		
BIT	NAME	FUNCTION
7:2	-	Reserved
1:0	FIFO_GSLEEP_SHARED_SRAM	Set selected SRAM bank global sleep mode Bit 0: <ol style="list-style-type: none"> 1. When set to 1: SRAM bank-0 will remain enabled 2. When 0: permits SRAM bank-0 to go to sleep mode <ol style="list-style-type: none"> a. SRAM bank goes to sleep, if not allocated as FIFO memory space b. If allocated as FIFO memory space, remains active unless FIFO is empty and sensors are off Bit 1: <ol style="list-style-type: none"> 1. When set to 1: SRAM bank-1 will remain enabled 2. When 0: Permits SRAM bank-1 to go to sleep mode <ol style="list-style-type: none"> a. SRAM bank goes to sleep, if not allocated as FIFO memory space b. If allocated as FIFO memory space, remains active unless FIFO is empty and sensors are off

21 USER BANK IPREG_SYS1 REGISTER MAP – DESCRIPTIONS

This section describes the function and contents of each register within user bank IPREG_SYS1. The registers described in this section are indirect access registers. Section 13 describes the procedure for accessing indirect access registers.

21.1 IPREG_SYS1_REG_42

Name: IPREG_SYS1_REG_42 Address: 42 (2Ah) Serial IF: R/W Reset value: 0x00 Clock Domain: MCLK		
BIT	NAME	FUNCTION
7:0	GYRO_X_OFFUSER[7:0]	Low bits for X-gyro offset programmed by user. Range is ± 62.5 dps, resolution is 7.5mdps.

21.2 IPREG_SYS1_REG_43

Name: IPREG_SYS1_REG_43 Address: 43 (2Bh) Serial IF: R/W Reset value: 0x00 Clock Domain: MCLK		
BIT	NAME	FUNCTION
7:6	-	Reserved
5:0	GYRO_X_OFFUSER[13:8]	Upper bits for X-gyro offset programmed by user. Range is ± 62.5 dps, resolution is 7.5mdps.

21.3 IPREG_SYS1_REG_56

Name: IPREG_SYS1_REG_56 Address: 56 (38h) Serial IF: R/W Reset value: 0x00 Clock Domain: MCLK		
BIT	NAME	FUNCTION
7:0	GYRO_Y_OFFUSER[7:0]	Low bits for Y-gyro offset programmed by user. Range is ± 62.5 dps, resolution is 7.5mdps.

21.4 IPREG_SYS1_REG_57

Name: IPREG_SYS1_REG_57 Address: 57 (39h) Serial IF: R/W Reset value: 0x00 Clock Domain: MCLK		
BIT	NAME	FUNCTION
7:6	-	Reserved
5:0	GYRO_Y_OFFUSER[13:8]	Upper bits for Y-gyro offset programmed by user. Range is ± 62.5 dps, resolution is 7.5mdps.

21.5 IPREG_SYS1_REG_70

Name: IPREG_SYS1_REG_70 Address: 70 (46h) Serial IF: R/W Reset value: 0x00 Clock Domain: MCLK		
BIT	NAME	FUNCTION
7:0	GYRO_Z_OFFUSER[7:0]	Low bits for Z-gyro offset programmed by user. Range is ± 62.5 dps, resolution is 7.5mdps.

21.6 IPREG_SYS1_REG_71

Name: IPREG_SYS1_REG_71 Address: 71 (47h) Serial IF: R/W Reset value: 0x00 Clock Domain: MCLK		
BIT	NAME	FUNCTION
7:6	-	Reserved
5:0	GYRO_Z_OFFUSER[13:8]	Upper bits for Z-gyro offset programmed by user. Range is ± 62.5 dps, resolution is 7.5mdps.

21.7 IPREG_SYS1_REG_166

Name: IPREG_SYS1_REG_166 Address: 166 (A6h) Serial IF: R/W Reset value: 0x1B Clock Domain: MCLK		
BIT	NAME	FUNCTION
7	-	Reserved
6:5	GYRO_SRC_CTRL	Gyro SRC CTRL: 0: Interpolator and AAF FIR filter off 1: Interpolator off and AAF FIR filter on 2: Interpolator on and AAF FIR filter on 3: Reserved (debug mode)
4:0	-	Reserved

21.8 IPREG_SYS1_REG_170

Name: IPREG_SYS1_REG_170		
Address: 170 (AAh)		
Serial IF: R/W		
Reset value: 0x0A		
Clock Domain: MCLK		
BIT	NAME	FUNCTION
7:5	-	Reserved
4:1	GYRO_LP_AVG_SEL	Gyro Low Power Mode Averaging Filter Selection 0000: 1x 0001: 2x 0010: 4x 0011: 5x 0100: 7x 0101: 8x 0110: 10x 0111: 11x 1000: 16x 1001: 18x 1010: 20x 1011: 32x 1100: 64x Others: Reserved
0	-	Reserved

21.9 IPREG_SYS1_REG_172

Name: IPREG_SYS1_REG_172		
Address: 172 (ACh)		
Serial IF: R/W		
Reset value: 0x80		
Clock Domain: MCLK		
BIT	NAME	FUNCTION
7:3	-	Reserved
2:0	GYRO_UI_LPFBW_SEL	Selects cut-off bandwidth for Gyro UI path LPF 000: Bypass 001: ODR/4 010: ODR/8 011: ODR/16 100: ODR/32 101: ODR/64 110: ODR/128 111: ODR/128

Note: When the FIR AAF is enabled, the signal path BW is decided by the FIR AAF and UI LPF combination. Please refer to AN-000365 ICM-456xx User Guide for details.

22 USER BANK IPREG_SYS2 REGISTER MAP – DESCRIPTIONS

This section describes the function and contents of each register within user bank IPREG_SYS2. The registers described in this section are indirect access registers. Section 13 describes the procedure for accessing indirect access registers.

22.1 IPREG_SYS2_REG_24

Name: IPREG_SYS2_REG_24 Address: 24 (18h) Serial IF: R/W Reset value: 0x00 Clock Domain: MCLK		
BIT	NAME	FUNCTION
7:0	ACCEL_X_OFFUSER[7:0]	Low bits for X-accel offset programmed by user. Range is $\pm 1g$, resolution is 0.125mg.

22.2 IPREG_SYS2_REG_25

Name: IPREG_SYS2_REG_25 Address: 25 (19h) Serial IF: R/W Reset value: 0x00 Clock Domain: MCLK		
BIT	NAME	FUNCTION
7:6	-	Reserved
5:0	ACCEL_X_OFFUSER[13:8]	Upper bits for X-accel offset programmed by user. Range is $\pm 1g$, resolution is 0.125mg.

22.3 IPREG_SYS2_REG_32

Name: IPREG_SYS2_REG_32 Address: 32 (20h) Serial IF: R/W Reset value: 0x00 Clock Domain: MCLK		
BIT	NAME	FUNCTION
7:0	ACCEL_Y_OFFUSER[7:0]	Low bits for Y-accel offset programmed by user. Range is $\pm 1g$, resolution is 0.125mg.

22.4 IPREG_SYS2_REG_33

Name: IPREG_SYS2_REG_33 Address: 33 (21h) Serial IF: R/W Reset value: 0x00 Clock Domain: MCLK		
BIT	NAME	FUNCTION
7:6	-	Reserved
5:0	ACCEL_Y_OFFUSER[13:8]	Upper bits for Y-accel offset programmed by user. Range is $\pm 1g$, resolution is 0.125mg.

22.5 IPREG_SYS2_REG_40

Name: IPREG_SYS2_REG_40 Address: 40 (28h) Serial IF: R/W Reset value: 0x00 Clock Domain: MCLK		
BIT	NAME	FUNCTION
7:0	ACCEL_Z_OFFUSER[7:0]	Low bits for Z-accel offset programmed by user. Range is $\pm 1g$, resolution is 0.125mg.

22.6 IPREG_SYS2_REG_41

Name: IPREG_SYS2_REG_41 Address: 41 (29h) Serial IF: R/W Reset value: 0x00 Clock Domain: MCLK		
BIT	NAME	FUNCTION
7:6	-	Reserved
5:0	ACCEL_Z_OFFUSER[13:8]	Upper bits for Z-accel offset programmed by user. Range is $\pm 1g$, resolution is 0.125mg.

22.7 IPREG_SYS2_REG_123

Name: IPREG_SYS2_REG_123 Address: 123 (7Bh) Serial IF: R/W Reset value: 0x14 Clock Domain: MCLK		
BIT	NAME	FUNCTION
7:2	-	Reserved
1:0	ACCEL_SRC_CTRL	Accel SRC CTRL: 0: Interpolator and AAF FIR filter off 1: Interpolator off and AAF FIR filter on 2: Interpolator on and AAF FIR filter on 3: Reserved (debug mode)

22.8 IPREG_SYS2_REG_129

Name: IPREG_SYS2_REG_129		
Address: 129 (81h)		
Serial IF: R/W		
Reset value: 0x02		
Clock Domain: MCLK		
BIT	NAME	FUNCTION
7:4	-	Reserved
3:0	ACCEL_LP_AVG_SEL	Accel Low Power Mode Averaging Filter Selection 0000: 1x 0001: 2x 0010: 4x 0011: 5x 0100: 7x 0101: 8x 0110: 10x 0111: 11x 1000: 16x 1001: 18x 1010: 20x 1011: 32x 1100: 64x Others: Reserved

22.9 IPREG_SYS2_REG_131

Name: IPREG_SYS2_REG_131		
Address: 131 (83h)		
Serial IF: R/W		
Reset value: 0x00		
Clock Domain: MCLK		
BIT	NAME	FUNCTION
7:3	-	Reserved
2:0	ACCEL_UI_LPFBW_SEL	Selects cut-off bandwidth for Accel UI path LPF 000: Bypass 001: ODR/4 010: ODR/8 011: ODR/16 100: ODR/32 101: ODR/64 110: ODR/128 111: ODR/128

Note: When the FIR AAF is enabled, the signal path BW is decided by the FIR AAF and UI LPF combination. Please refer to AN-000365 ICM-456xx User Guide for details.

23 REFERENCE

Please refer to the following application notes for additional information.

- IxM-4xxxx, IxM-2xxxx and MPU-6xxx Products PCB Design, Mounting, and Handling Guidelines (AN-000393)
- Understanding IMU Sensor Offset (AN-000257)
- TDK InvenSense IMU Calibration Application Note (AN-000265)
- ICM-456xx Errata Update (AN-000364)
- ICM-45605 & ICM-45686 User Guide (AN-000478)

24 REVISION HISTORY

Revision Date	Revision	Description
07/25/2024	1.0	Initial Release

This information furnished by InvenSense or its affiliates (“TDK InvenSense”) is believed to be accurate and reliable. However, no responsibility is assumed by TDK InvenSense for its use, or for any infringements of patents or other rights of third parties that may result from its use. Specifications are subject to change without notice. TDK InvenSense reserves the right to make changes to this product, including its circuits and software, in order to improve its design and/or performance, without prior notice. TDK InvenSense makes no warranties, neither expressed nor implied, regarding the information and specifications contained in this document. TDK InvenSense assumes no responsibility for any claims or damages arising from information contained in this document, or from the use of products and services detailed therein. This includes, but is not limited to, claims or damages based on the infringement of patents, copyrights, mask work and/or other intellectual property rights.

Certain intellectual property owned by InvenSense and described in this document is patent protected. No license is granted by implication or otherwise under any patent or patent rights of InvenSense. This publication supersedes and replaces all information previously supplied. Trademarks that are registered trademarks are the property of their respective companies. TDK InvenSense sensors should not be used or sold in the development, storage, production or utilization of any conventional or mass-destructive weapons or for any other weapons or life threatening applications, as well as in any other life critical applications such as medical equipment, transportation, aerospace and nuclear instruments, undersea equipment, power plant equipment, disaster prevention and crime prevention equipment.

©2024 InvenSense. All rights reserved. InvenSense, MotionTracking, MotionProcessing, MotionProcessor, MotionFusion, MotionApps, DMP, AAR, and the InvenSense logo are trademarks of InvenSense, Inc. The TDK logo is a trademark of TDK Corporation. Other company and product names may be trademarks of the respective companies with which they are associated.



©2024 InvenSense. All rights reserved.