

NFC card reader expansion board based on ST25R200 for STM32 Nucleos

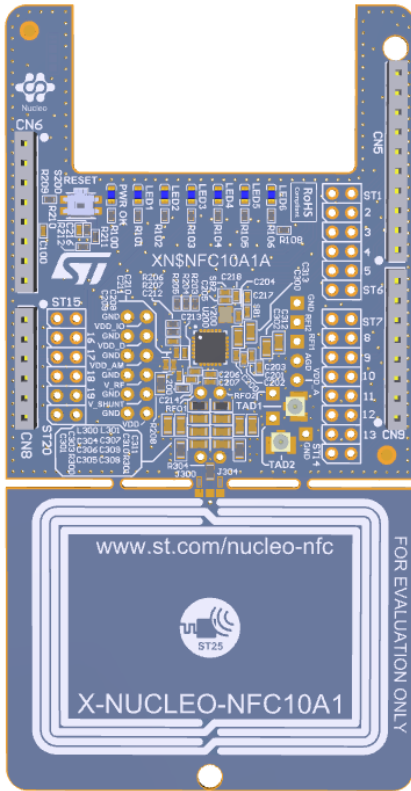

Features

- On-board NFC card reader IC: [ST25R200](#)
- 47 mm x 34 mm, four turns, 13.56 MHz inductive antenna etched on PCB and associated tuning circuit
- Six general-purpose LEDs
- ISO 14443A and ISO14443B
- ISO 15693
- Possibility of driving two antennas in single-ended configuration
- Equipped with Arduino UNO R3 connector
- Free comprehensive development firmware library compatible with [STM32Cube](#) and samples for [ST25R200](#)
- Scalable solution for multiple board cascade
- FCC certified
- RoHS and WEEE compliant

Description

The [X-NUCLEO-NFC10A1](#) NFC card reader expansion board is based on the [ST25R200](#) device.

The expansion board is configured to support ISO14443A/B, ISO15693.

The [ST25R200](#) manages frame coding and decoding in reader mode for standard applications, such as NFC, proximity, and vicinity HF RFID standards. It supports ISO/IEC 14443 type A/B and ISO/IEC 15693 RF communication protocols as well as the detection, reading and writing of NFC Forum type 1, 2, 4, and 5 tags.

It embeds a low power wake-up system capable of detecting an approaching tag. It also features a low power RC oscillator and wake-up timer to wake up the device automatically after a selected time period and check for a tag presence.

Product summary

NFC card reader expansion board based on ST25R200 for STM32 and STM8 Nucleos	X-NUCLEO-NFC10A1
High-performance NFC universal device and EMVCo reader	ST25R200-BMET
High-performance HF reader/NFC initiator IC software expansion for STM32Cube	X-CUBE-NFC10
Applications	Wireless Connectivity

1 Schematic diagrams

Figure 1. X-NUCLEO-NFC10A1 circuit schematic (1 of 3)

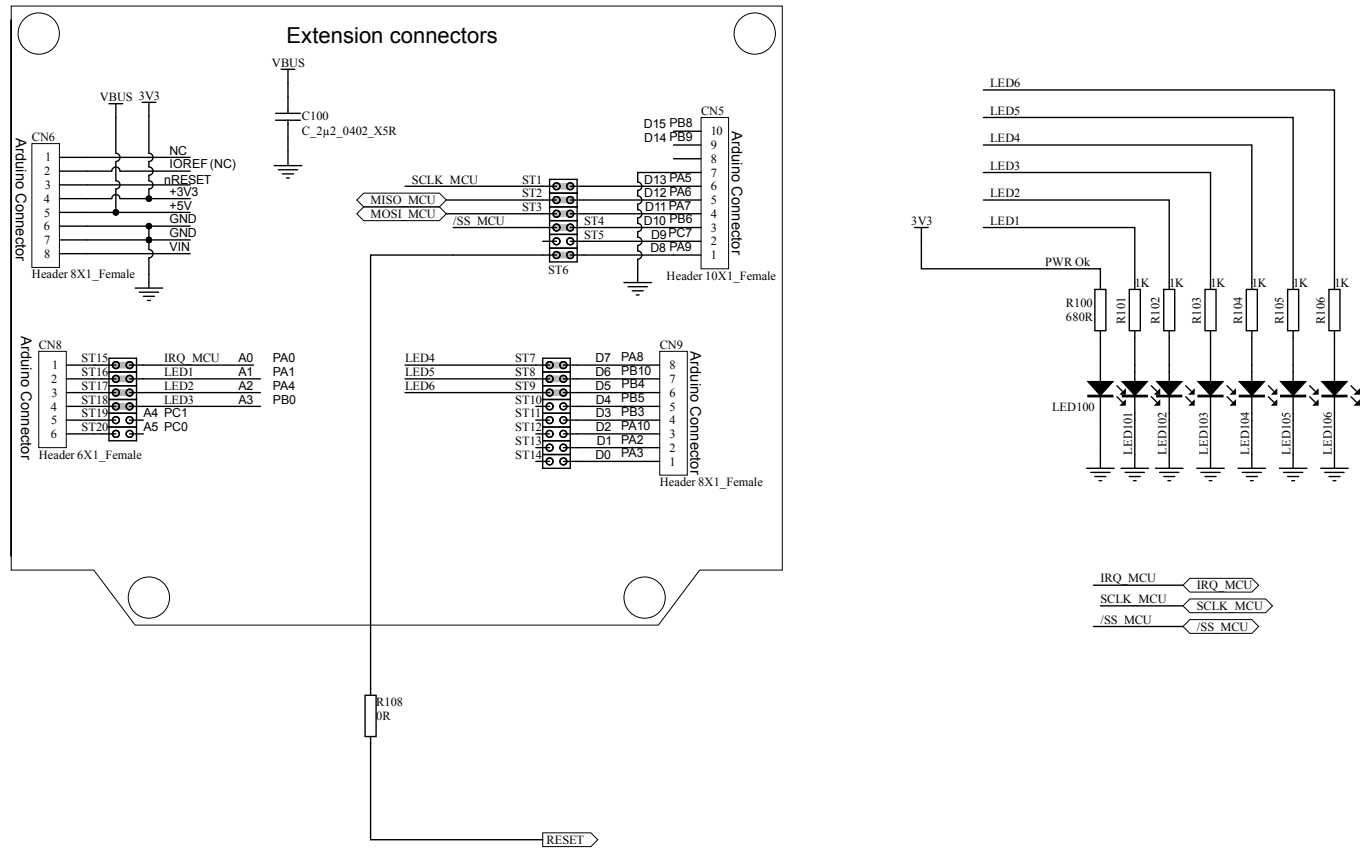

Figure 2. X-NUCLEO-NFC10A1 circuit schematic (2 of 3)

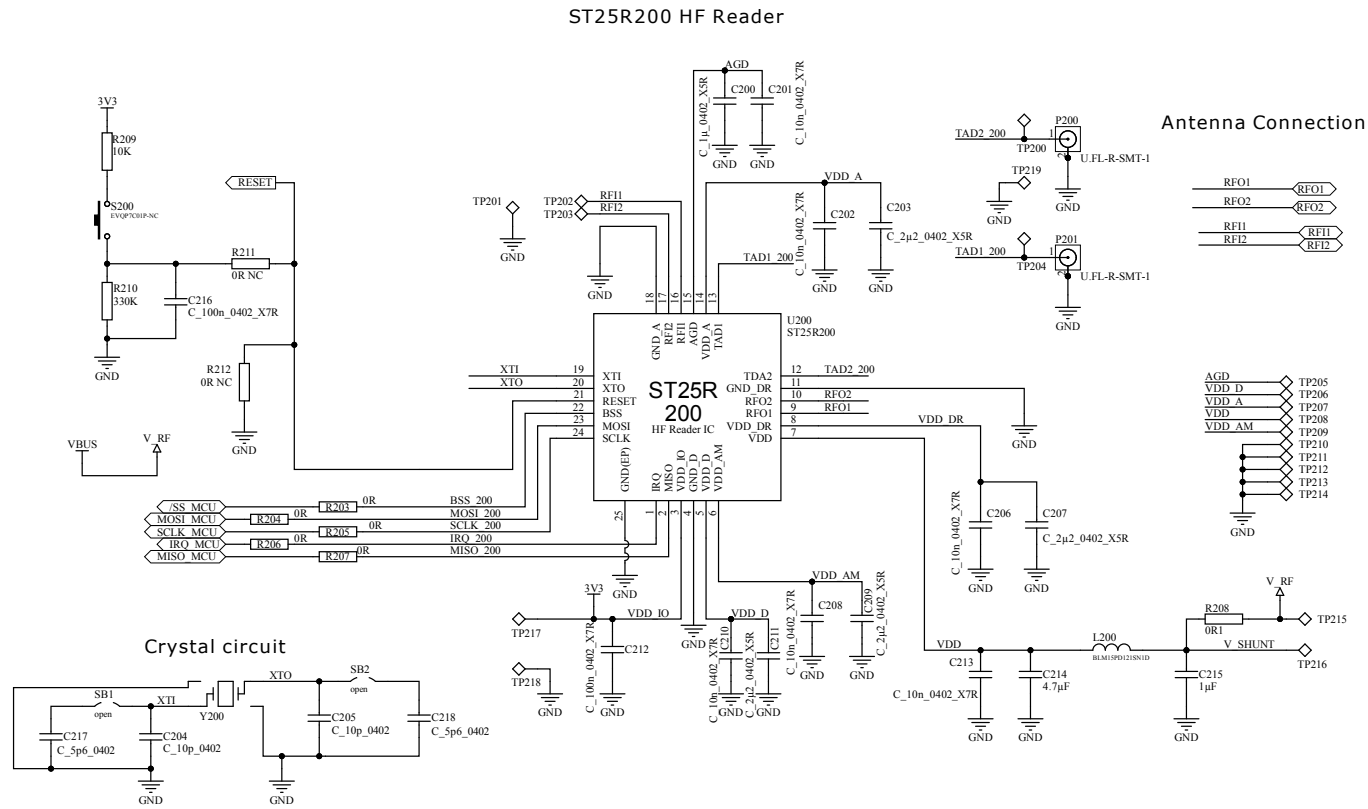
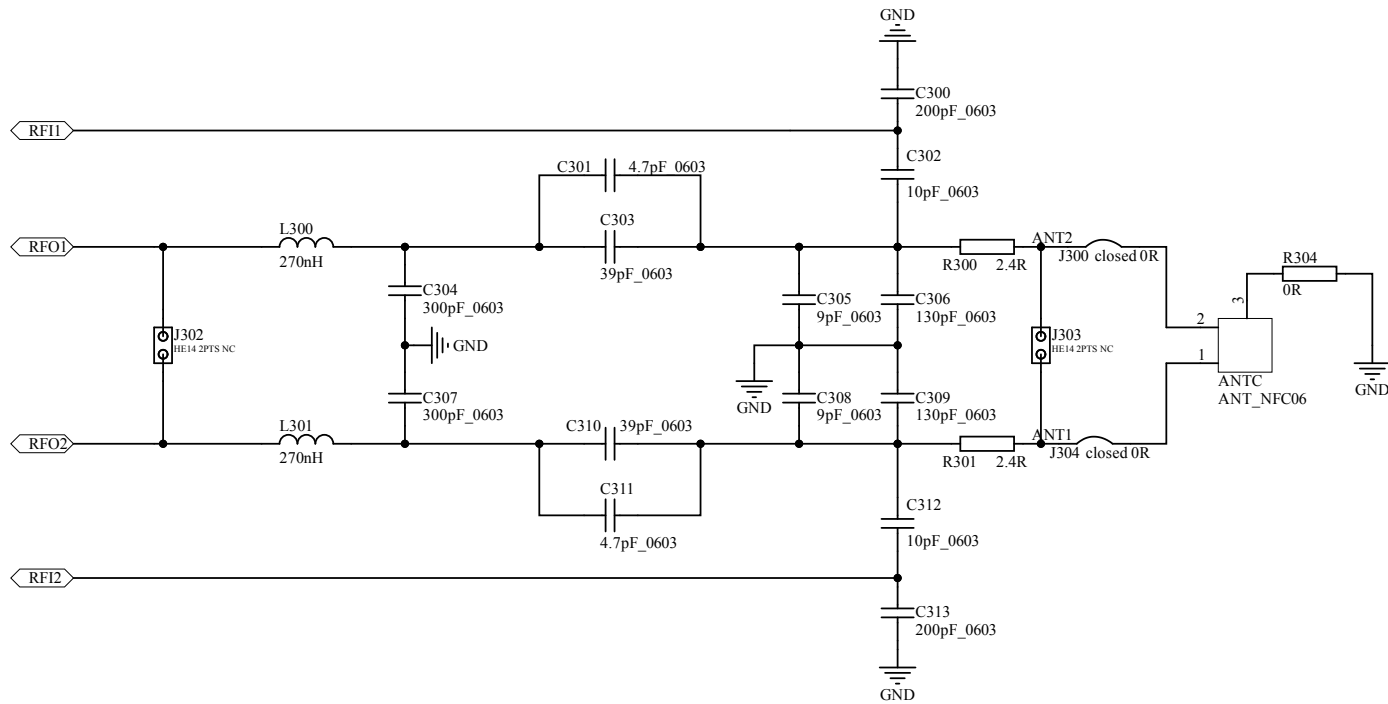

Figure 3. X-NUCLEO-NFC10A1 circuit schematic (3 of 3)

Antenna Circuit incl. EMI Filter and Matching



2 Board versions

Table 1. X-NUCLEO-NFC10A1 versions

PCB version	Schematic diagrams	Bill of materials
XN\$NFC10A1A ⁽¹⁾	XN\$NFC10A1A schematic diagrams	XN\$NFC10A1A bill of materials

1. This code identifies the X-NUCLEO-NFC10A1 expansion board first version. It is printed on the board PCB.

Revision history

Table 2. Document revision history

Date	Revision	Changes
17-Jul-2024	1	Initial release.

IMPORTANT NOTICE – READ CAREFULLY

STMicroelectronics NV and its subsidiaries (“ST”) reserve the right to make changes, corrections, enhancements, modifications, and improvements to ST products and/or to this document at any time without notice. Purchasers should obtain the latest relevant information on ST products before placing orders. ST products are sold pursuant to ST’s terms and conditions of sale in place at the time of order acknowledgment.

Purchasers are solely responsible for the choice, selection, and use of ST products and ST assumes no liability for application assistance or the design of purchasers’ products.

No license, express or implied, to any intellectual property right is granted by ST herein.

Resale of ST products with provisions different from the information set forth herein shall void any warranty granted by ST for such product.

ST and the ST logo are trademarks of ST. For additional information about ST trademarks, refer to www.st.com/trademarks. All other product or service names are the property of their respective owners.

Information in this document supersedes and replaces information previously supplied in any prior versions of this document.

© 2024 STMicroelectronics – All rights reserved