

TC Series

Chip Tantalum Capacitors (Large Capacitance)



FEATURES

- Ta-MnO₂ technology
- Low DCL
- Parameters stability over voltage and time
- Undertab and J-lead LF



LEAD-FREE
LEAD-FREE COMPATIBLE
COMPONENT



APPLICATIONS

- DC/DC
- Industrial
- Telecom
- IoT
- Home applications
- Sensors

MARKING A CASE

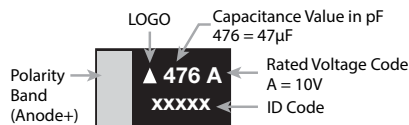

M, P CASE

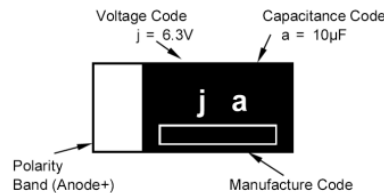

UNDERTAB M CASE

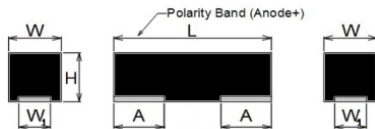

CASE DIMENSIONS:

millimeters (inches)

Code	EIA Code	EIA Metric	L±0.10 (0.004)	W±0.10 (0.004)	H±0.10 (0.004)	W ₁ ±0.10 (0.004)	A±0.10 (0.004)
M	0603	1608-09	1.60 (0.063)	0.85 (0.033)	0.80 (0.031)	0.55 (0.022)	0.50 (0.020)

J-LEAD A, P CASE

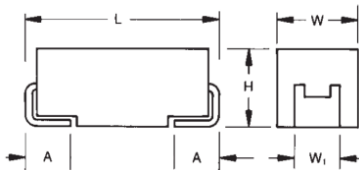

CASE DIMENSIONS:

millimeters (inches)

Code	EIA Code	EIA Metric	L±0.20 (0.008)	W±0.20 (0.008)	H±0.20 (0.008)	W ₁ ±0.20 (0.008)	A±0.30 (0.012)
A	1206	3216-18	3.20 (0.126)	1.60 (0.063)	1.60 (0.063)	1.20 (0.047)	0.80 (0.031)
P	0805	2012-12	2.00 (0.079)	1.25 (0.049)	1.20 (0.047) max.	0.90 (0.035)	0.45 (0.018)

HOW TO ORDER

TC
Type

M
Case Size
See table
above

0J
Rated DC Voltage
0G = 4Vdc
0J = 6.3Vdc
1A = 10Vdc
1C = 16Vdc
1D = 20Vdc
1E = 25Vdc
1H = 50Vdc

475
Capacitance Code
pF code: 1st two digits
represent significant figures,
3rd digit represents multiplier
(number of zeros to follow)

M
Tolerance
K = ±10%
M = ±20%

8R
Packaging
8 = Tape width
R = Positive electrode
on the side opposite to
sprocket hole

- □□□
Discrimination code

TC Series

Chip Tantalum Capacitors (Large Capacitance)

TECHNICAL SPECIFICATIONS

Technical Data:	All technical data relate to an ambient temperature of +25°C
Capacitance Range:	0.15µF to 100µF
Capacitance Tolerance:	±20%
Leakage Current DCL:	Please see the ratings and part number reference table below
Temperature Range:	-55°C to +125°C

CAPACITANCE AND RATED VOLTAGE RANGE (LETTER DENOTES CASE SIZE)

Capacitance		Rated Voltage DC (V _R) @ 85°C							Cap Code
µF	Code	4V (g)	6.3V (j)	10V (A)	16V (C)	20V(D)	25V(E)	50V(H)	
0.15	154							A	E
1.0	105			P	A,M,P	A	A,M,P		A
1.5	155				A				E
2.2	225		P	A,M,P	A,M				J
3.3	335			A,P	A		A		N
4.7	475		A,M,P	A,M,P	A	A	A		S
6.8	685		P	A	A				W
10	106	A,M,P	A,M,P	A*,M,P	A*				a
15	156		P	A					e
22	226	A,M,P	A,M,P	A	A				j
33	336	A	A,M	A					n
47	476	A	A						s
68	686	A							w
100	107	A							ā

Released ratings (*K tolerance is also available)

Note: Voltage ratings are minimum values. KYOCERA AVX reserves the right to supply higher voltage ratings in the same case size, to the same reliability standards.

RATINGS & PART NUMBER REFERENCE

Part No.	Case Size	Capacitance (µF)	Rated Voltage (V)	Maximum Operating Temp. (°C)	DCL Max. (µA)	DF Max. (%)	Impedance @100kHz (Ω)	MSL
4 Volt								
TCA0G106M8R	A	10	4	125	0.5	8	4.2	1
TCM0G106M8R	M	10	4	125	0.5	20	9	1
TCP0G106M8R	P	10	4	125	0.5	20	9.3	1
TCA0G226M8R	A	22	4	125	0.9	8	3	1
TCM0G226M8R	M	22	4	125	0.9	20	9	1
TCP0G226M8R	P	22	4	125	0.9	20	7.7	1
TCA0G336M8R	A	33	4	125	1.3	10	3.5	1
TCA0G476M8R	A	47	4	125	1.9	12	3.2	1
TCA0G686M8R	A	68	4	125	2.7	18	3	1
TCA0G107M8R	A	100	4	125	4.0	30	3	1
TCA0G107M8R-02	A	100	4	125	3.8	30	4	1
6.3 Volt								
TCP0J225M8R	P	2.2	6.3	125	0.5	20	17.5	1
TCA0J475M8R	A	4.7	6.3	125	0.5	8	4.9	1
TCM0J475M8R	M	4.7	6.3	125	0.5	20	9	1
TCP0J475M8R	P	4.7	6.3	125	0.5	20	11.8	1
TCP0J685M8R	P	6.8	6.3	125	0.5	20	9.3	1
TCA0J106M8R	A	10	6.3	125	0.6	8	4	1
TCM0J106M8R	M	10	6.3	125	0.6	20	9	1
TCM0J106M8R-02	M	10	6.3	125	0.6	20	9	1
TCM0J106M8R-CA2	M	10	6.3	125	0.3	20	8	1
TCP0J106M8R	P	10	6.3	125	0.6	20	8.3	1
TCP0J106M8R-02	P	10	6.3	125	0.1	20	6	1
TCP0J106M8R-Y1	P	10	6.3	125	0.6	20	8.3	1
TCP0J156M8R	P	15	6.3	125	0.9	20	7.7	1
TCA0J226M8R	A	22	6.3	125	1.4	10	3.5	1
TCM0J226M8R-CA2	M	22	6.3	125	6.9	20	8	1
TCM0J226M8R-EV2	M	22	6.3	125	13.0	30	9	1
TCM0J226M8R-V1	M	22	6.3	125	13.0	30	9	1
TCP0J226M8R	P	22	6.3	125	1.4	25	5	1
TCP0J226M8R-02	P	22	6.3	125	1.4	25	5	1

TC Series

Chip Tantalum Capacitors (Large Capacitance)



RATINGS & PART NUMBER REFERENCE

Part No.	Case Size	Capacitance (µF)	Rated Voltage (V)	Maximum Operating Temp. (°C)	DCL Max. (µA)	DF Max. (%)	Impedance @100kHz (Ω)	MSL
TCA0J336M8R	A	33	6.3	125	2.1	12	3.2	1
TCA0J336M8R-E1	A	33	6.3	125	2.1	12	3.2	1
TCM0J336M8R-V1	M	33	6.3	125	208.0	30	9	1
TCA0J476M8R	A	47	6.3	125	3.0	18	3.2	1
TCA0J476M8R-02	A	47	6.3	125	3.0	18	3.2	1
TCA0J476M8R-E1	A	47	6.3	125	3.0	18	3.2	1
10 Volt								
TCP1A105M8R	P	1.0	10	125	0.5	10	17.5	1
TCA1A225M8R	A	2.2	10	125	0.5	6	5.6	1
TCM1A225M8R	M	2.2	10	125	0.5	20	13.5	1
TCP1A225M8R	P	2.2	10	125	0.5	20	14.4	1
TCA1A335M8R	A	3.3	10	125	0.5	8	4.9	1
TCP1A335M8R	P	3.3	10	125	0.5	20	11.8	1
TCA1A475M8R	A	4.7	10	125	0.5	8	4.2	1
TCM1A475M8R	M	4.7	10	125	0.5	20	9	1
TCM1A475M8R-E1	M	4.7	10	125	0.5	20	9	1
TCP1A475M8R	P	4.7	10	125	0.5	20	9.3	1
TCA1A685M8R	A	6.8	10	125	0.7	8	4	1
TCA1A106*8R	A	10	10	125	1.0	8	3	1
TCM1A106M8R	M	10	10	125	10.0	20	9	1
TCM1A106M8R-02	M	10	10	125	10.0	20	9	1
TCM1A106M8R-CA2	M	10	10	125	2.0	20	8	1
TCP1A106M8R	P	10	10	125	1.0	20	7.7	1
TCP1A106M8R-02	P	10	10	125	1.0	20	7.7	1
TCA1A156M8R	A	15	10	125	1.5	10	3.5	1
TCA1A226M8R	A	22	10	125	2.2	12	3.2	1
TCA1A336M8R	A	33	10	125	3.3	8	1.7	1
16 Volt								
TCA1C105M8R	A	1.0	16	125	0.5	6	7	1
TCM1C105M8R	M	1.0	16	125	0.5	10	15	1
TCM1C105M8R-02	M	1.0	16	125	0.5	10	15	1
TCP1C105M8R	P	1.0	16	125	0.5	10	16.1	1
TCA1C155M8R	A	1.5	16	125	0.5	6	5.6	1
TCA1C225M8R	A	2.2	16	125	0.5	6	4.9	1
TCM1C225M8R	M	2.2	16	125	0.5	20	13.5	1
TCM1C225M8R-CA2	M	2.2	16	125	0.5	20	13.5	1
TCA1C335M8R	A	3.3	16	125	0.5	6	4.8	1
TCA1C475M8R	A	4.7	16	125	0.8	6	3.9	1
TCA1C685M8R	A	6.8	16	125	1.1	6	3.8	1
TCA1C106*8R	A	10	16	125	1.6	8	3.5	1
TCA1C106K8R-02	A	10	16	125	1.6	8	3.5	1
TCA1C106M8R-02	A	10	16	125	1.3	8	2.6	1
TCA1C226M8R	A	22	16	125	3.5	30	2.3	1
20 Volt								
TCA1D105M8R	A	1.0	20	125	0.5	6	7	1
TCA1D475M8R	A	4.7	20	125	0.9	6	3.9	1
25 Volt								
TCA1E105M8R	A	1.0	25	125	0.5	6	7	1
TCM1E105M8R	M	1.0	25	125	0.5	10	10	1
TCP1E105M8R	P	1.0	25	125	0.6	20	9.3	1
TCA1E335M8R	A	3.3	25	125	0.8	6	4.8	1
TCA1E475M8R	A	4.7	25	125	1.2	8	3.4	1
50 Volt								
TCA1H154M8R	A	0.15	50	125	0.5	4	15	1

Moisture Sensitivity Level (MSL) is defined according to J-STD-020.
All technical data relates to an ambient temperature of +25C.

Capacitance and DF are measured at 120Hz, 0.5RMS with DC bias of 1.5 volts.
DCL is measured at rated voltage after 5 minutes.
Impedance allowed to move up to 1.25 times catalog limit post mounting.

NOTE: KYOCERA AVX reserves the rights to supply higher voltage rating in the same case size, to the same reliability standards.

TC Series

Chip Tantalum Capacitors (Large Capacitance)

QUALIFICATION TABLE

TEST	TC series (Temperature range -55°C to +125°C)						
	Condition			Characteristics			
Endurance	Apply rated voltage (Ur) at 85°C for 1000hrs (for M and P case) 2000hrs (for A case) through a serial resistance of $\leq 3.0\Omega$. Stabilize at room temperature for 24 hours before measuring.			Visual examination	no visible damage		
				DCL	2x initial limit		
				$\Delta C/C$	within $\pm 30\%$ of initial value (M case), $\pm 20\%$ (A,P case)		
				DF	2x initial limit		
Humidity	Store at $60\pm 2^\circ\text{C}$, 90-95% relative humidity for 500+12/0 hours. Stabilize at room temperature and humidity for 24 hours before measuring.			Visual examination	no visible damage		
				DCL	2x initial limit		
				$\Delta C/C$	within $\pm 30\%$ of initial value (M case), $\pm 20\%$ (A,P case)		
				DF	2x initial limit		
Temperature Stability	Step	Temperature $^\circ\text{C}$	Duration(min)				
	1	-55	15	-55 $^\circ\text{C}$	+85 $^\circ\text{C}$	+125 $^\circ\text{C}$	
	2	+85	15	DCL	n/a	10xIL*	12.5xIL*
	3	+125	15	$\Delta C/C$	0/-30%	+15/-5%	+20/-5%
				DF	IL*	IL*	IL*
Surge Voltage	Apply 1.3x rated voltage (Ur) at $85\pm 2^\circ\text{C}$ for 1000 cycles, 300sec charge and 30sec discharge resistance 1000 Ω .			Visual examination	no visible damage		
				DCL	2x initial limit		
				$\Delta C/C$	$\pm 20\%$ of initial limit		
				DF	2x initial limit		
Vibration	4.17 JIS C 5101-1 Frequency: 10 to 55 to 10Hz/min. Amplitude: 1.5mm Time: 2hours each in X and Y directions			Visual examination	no visible damage		
				DCL	initial limit		
				$\Delta C/C$	within $\pm 5\%$ of initial value		
				DF	initial limit		

*Initial Limit

For use outside of recommended conditions and special request, please contact KYOCERA AVX.

Initial measurement max. 1hr after the removal from dry pack or after pretreatment at 85°C for 24 hours.

PACKAGING SPECIFICATIONS

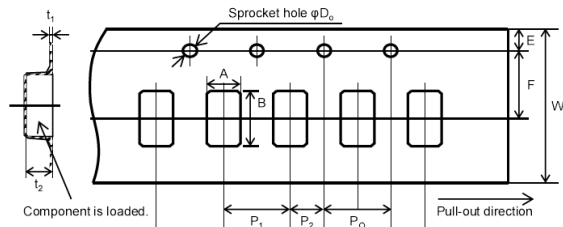

Unit (mm)

Case	A ± 0.10	B ± 0.10	W ± 0.20	E ± 0.10	F ± 0.05	P1 ± 0.10	P2 ± 0.05	PO ± 0.10	DO $\pm 0.10/0$	t1 ± 0.05	t2 ± 0.10	Standard packaging quantity
A	1.83	3.57	8.00	1.75	3.50	4.00	2.00	4.00	$\phi 1.50$	0.17	1.87	2,000 pcs
M	1.00	1.85	8.00	1.75	3.50	4.00	2.00	4.00	$\phi 1.50$	0.20	1.00	4,000 pcs
P	1.55	2.30	8.00	1.75	3.50	4.00	2.00	4.00	$\phi 1.55\pm 0.05$	0.25	1.32	3,000 pcs

REEL DIMENSIONS M, P CASE

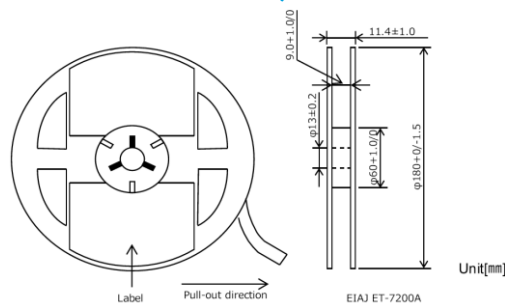

REEL DIMENSIONS A CASE

