

## Evaluation kit for industrial PLC solutions targeting SIL3 applications

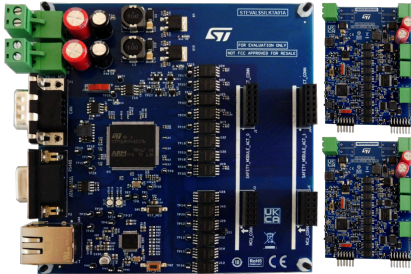

### Features

- Designed to meet IEC61508-2, EN 62061, EN ISO 13849-1, EN ISO 13849-2 for a SIL3/PLe achievement
- Dual core architecture based on [STM32H743ZG](#) and [STM32G431RB](#)
- Dual digital outputs [IPS1025H](#), [IPS4260L](#)
- Dual digital inputs [CLT03-1SC3](#)
- Full diagnostic coverage >90%
- Galvanic isolation for data transmission, and digital I/O signals using [STISO621](#)
- Redundancy on board, at hardware level and data processing
- Real time communication supporting Ethernet technology for Ethernet/IP, and differential serial communication for RS485 and CAN
- Overload and overtemperature protections, integrated on board at device level

### Description

The [STEVAL-SILKT01](#) is an evaluation kit designed to implement a PLC solution with hardware architecture designed to meet the requirements coming from functional safety standards IEC61508, EN 62061, EN ISO 13849-1, EN ISO 13849-2, to enable the use as a reference design for factory automation use cases having a hardware platform with safety integrity level SIL3.

The evaluation kit [STEVAL-SILKT01](#) contains one mother board [STEVAL-SILKTA01](#) (main board) and two daughter boards [STEVAL-SILKTB01](#) (actuation board).

The board architecture offers a dual-core data processing based on [STM32H743ZG](#) for the [STEVAL-SILKTA01](#) and on [STM32G431RB](#) for the [STEVAL-SILKTB01](#).

On the main board ([STEVAL-SILKTA01](#)) are available three connectivity interfaces, two of them with differential communication working on RS485 and CAN physical layer, the other one with Ethernet technology to support the Ethernet/IP.

The hardware is coming with the firmware package [STSW-SILKT01](#) based on the STM32Cube architecture and consisting of: application layer, drivers layer with BSP/CMSIS and HAL library, middleware layer.

Product summary	
Evaluation kit for industrial PLC solutions targeting SIL3 applications	<a href="#">STEVAL-SILKT01</a>
Software for <a href="#">STEVAL-SILKT01</a>	<a href="#">STSW-SILKT01</a>
High-performance and DSP with DP-FPU, Arm Cortex-M7 MCU with 1MByte of Flash memory, 1MB RAM, 480 MHz CPU, L1 cache, external memory interface, JPEG codec, large set of peripherals	<a href="#">STM32H743ZG</a>
Mainstream Arm Cortex-M4 MCU 170 MHz with 128 Kbytes of Flash memory, Math Accelerator, Medium Analog level integration	<a href="#">STM32G431RB</a>
Applications	Programmable Logic Controllers (PLC)

## 1 Industrial safety features

On both boards (STEVAL-SILKTA01 and STEVAL-SILKTB01) have been implemented architectural circuitries, able to:

- Cover diagnostic functions to achieve a coverage DC > 90%
- Implement redundancy on digital input using single channel digital input [CLT03-1SC3](#)
- Implement redundancy on digital output using high-side and low-side architecture ([IPS1025H](#) and [IPS4260L](#) respectively)
- Implement redundancy on the execution of safety functions
- Implement redundancy on digital output driving signals using dedicated logic gates
- Implement different power management circuitry to differentiate the power management unit for safety and non-safety related blocks

The STEVAL-SILKTA01 (main board) as well as the STEVAL-SILKTB01 (actuation board), embeds an isolation barrier based on [STISO621](#), managing:

- Serial communication between [STM32H743ZG](#) and [STM32G431RB](#)
- Digital input detection
- Digital output driving
- Diagnostic signalization for overload and overtemperature.



Figure 3. STEVAL-SILKTA01 circuit schematic (3 of 21)

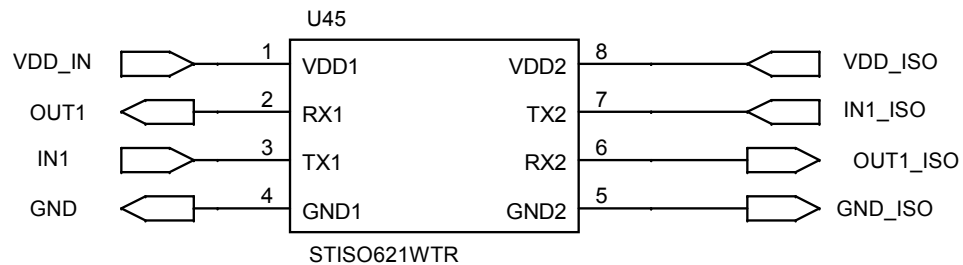

Figure 4. STEVAL-SILKTA01 circuit schematic (4 of 21)

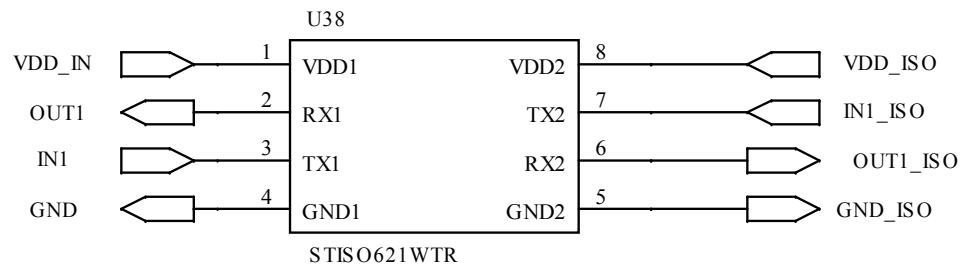

Figure 5. STEVAL-SILKTA01 circuit schematic (5 of 21)

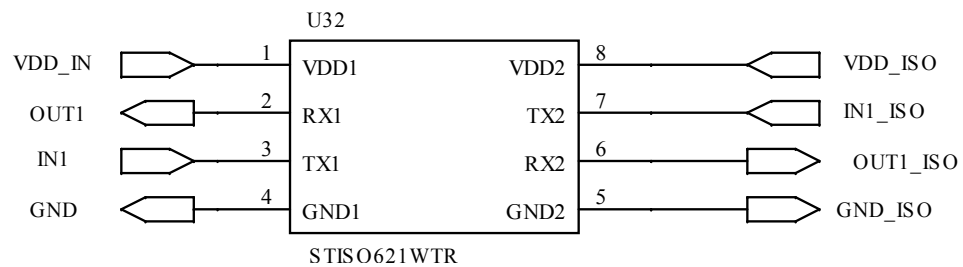

Figure 6. STEVAL-SILKTA01 circuit schematic (6 of 21)

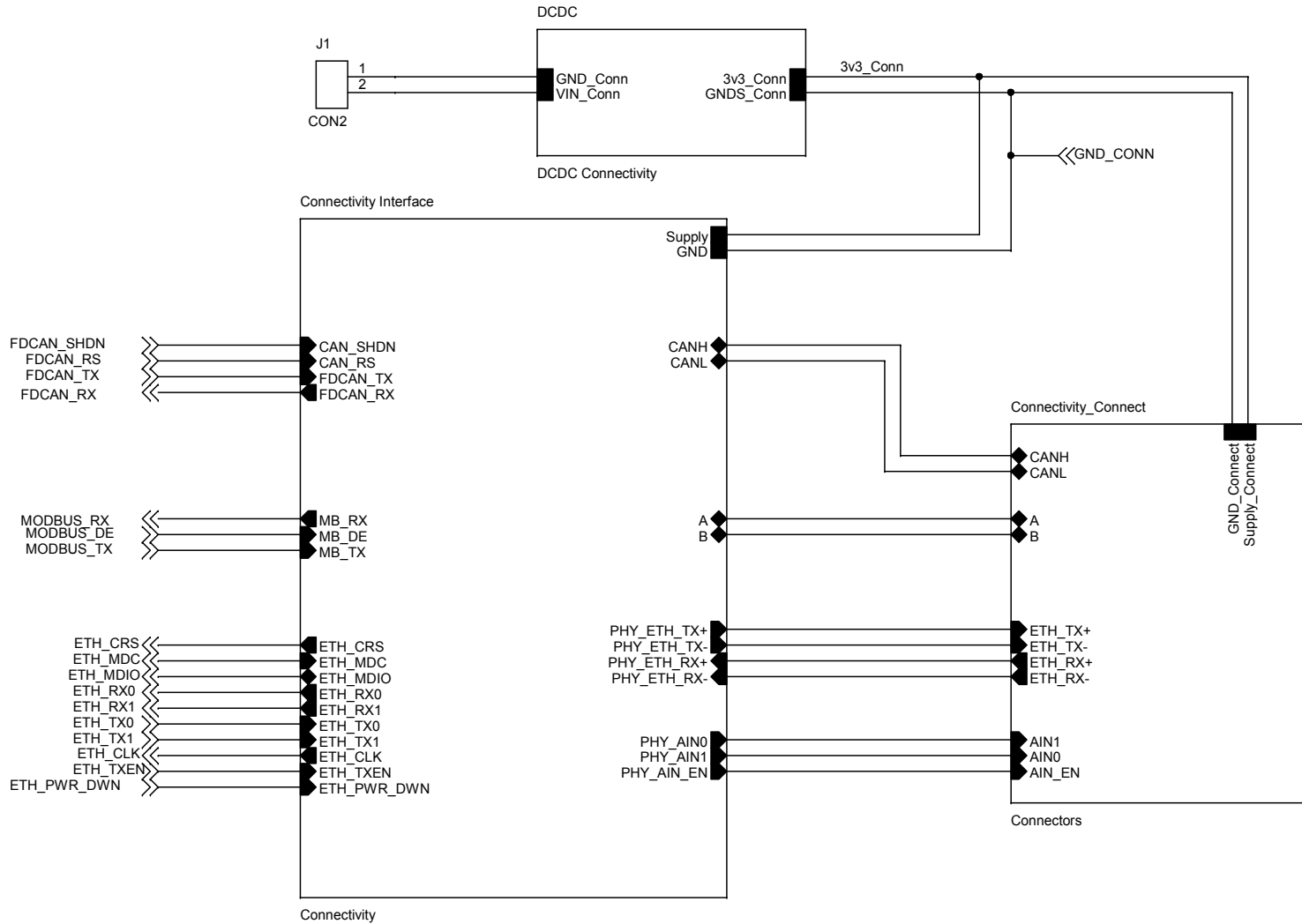
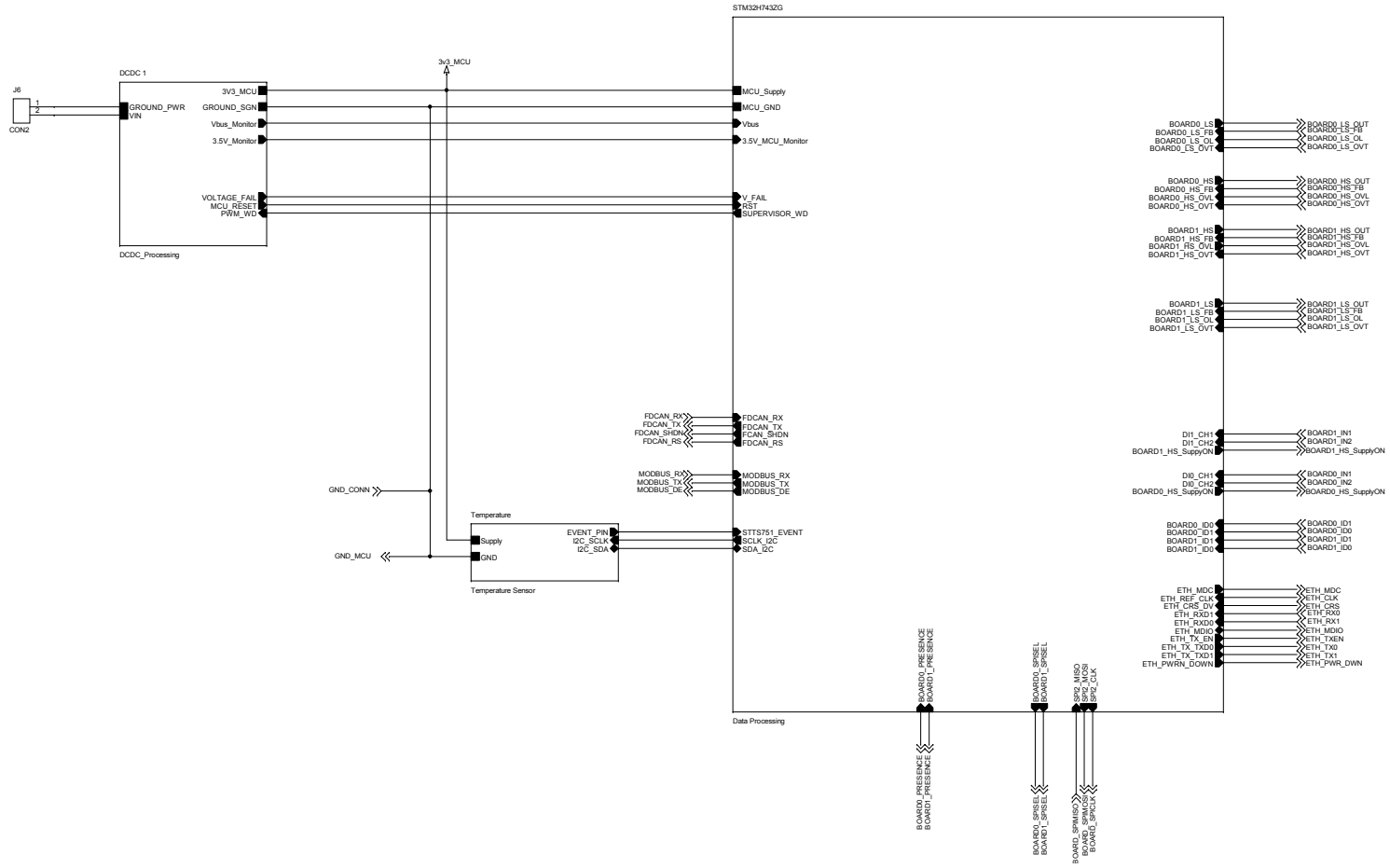



Figure 8. STEVAL-SILKTA01 circuit schematic (8 of 21)



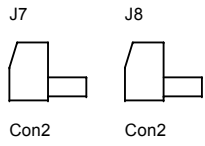

Figure 9. STEVAL-SILKTA01 circuit schematic (9 of 21)

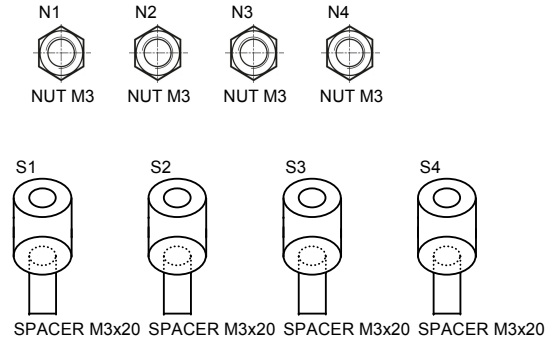





Figure 11. STEVAL-SILKTA01 circuit schematic (11 of 21)

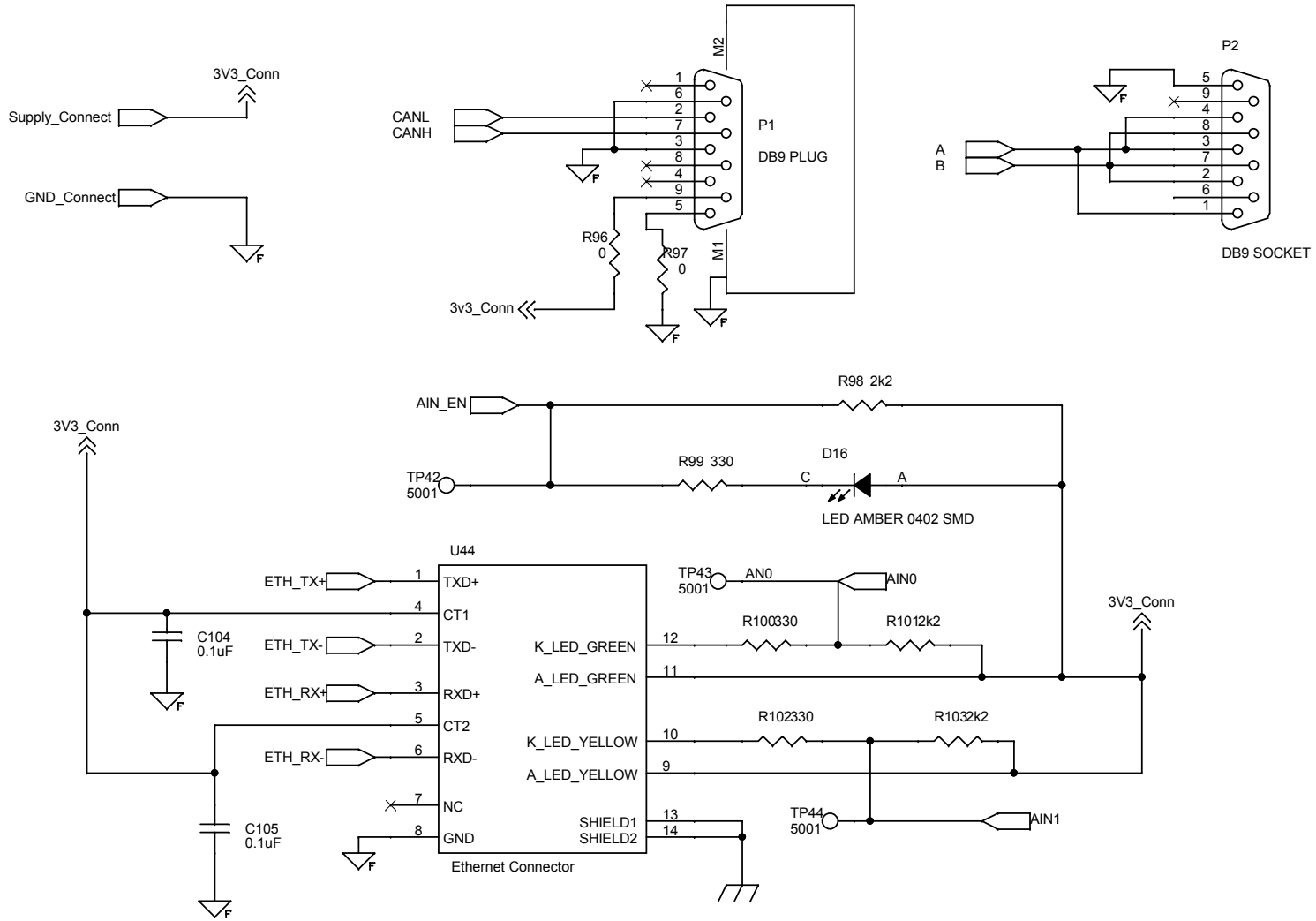



Figure 13. STEVAL-SILKTA01 circuit schematic (13 of 21)

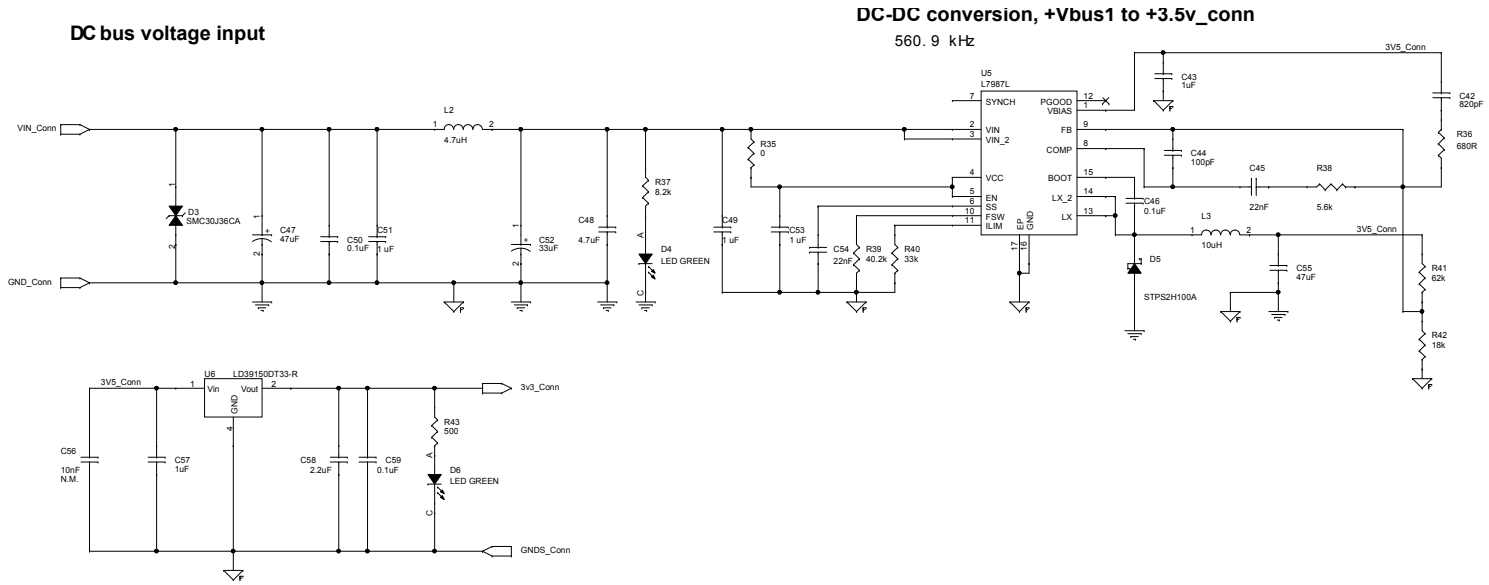

Figure 14. STEVAL-SILKTA01 circuit schematic (14 of 21)

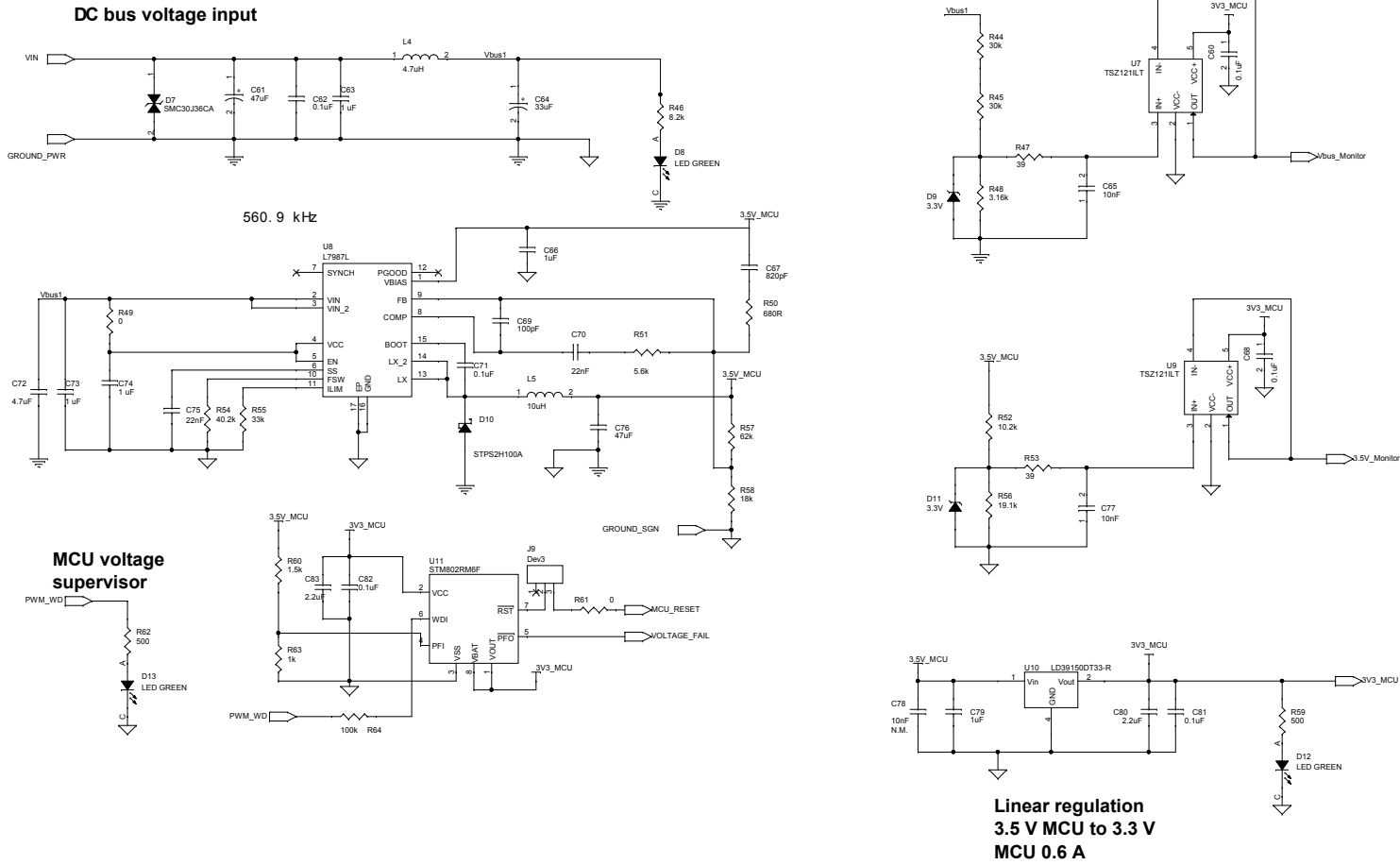

Figure 15. STEVAL-SILKTA01 circuit schematic (15 of 21)

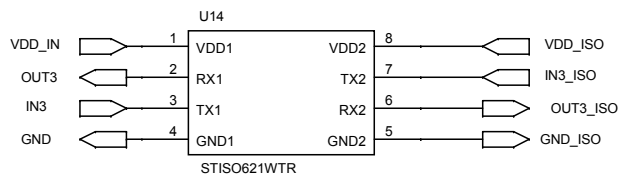
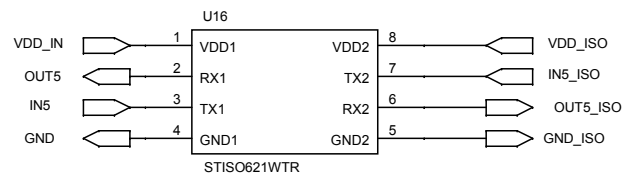
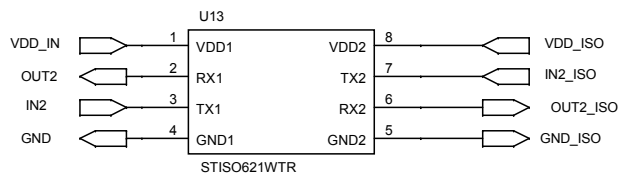
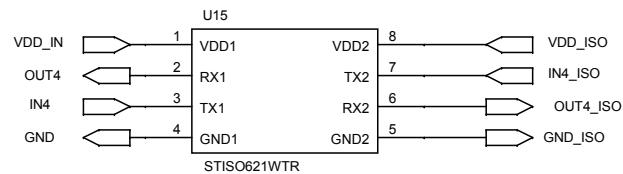
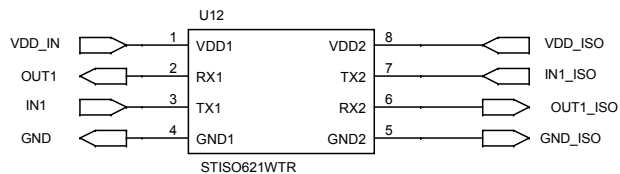

Figure 16. STEVAL-SILKTA01 circuit schematic (16 of 21)

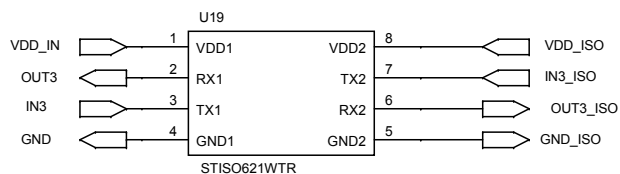
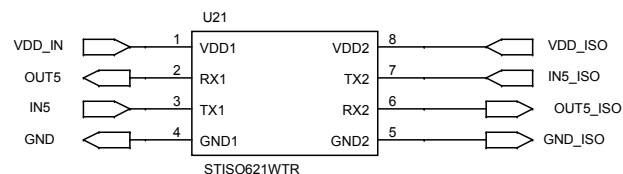
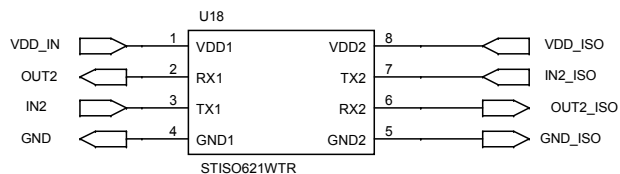
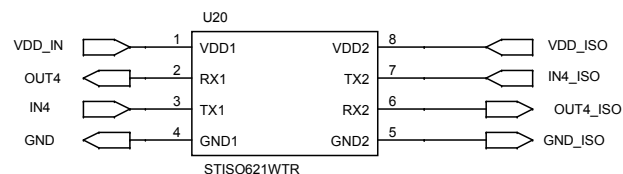
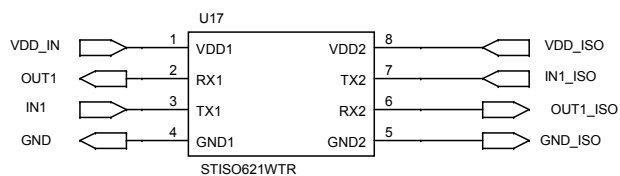

Figure 17. STEVAL-SILKTA01 circuit schematic (17 of 21)

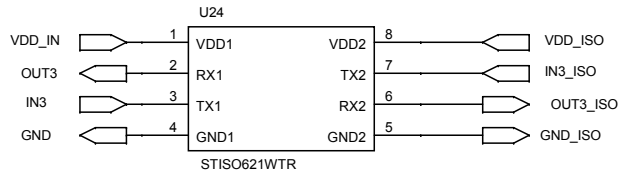
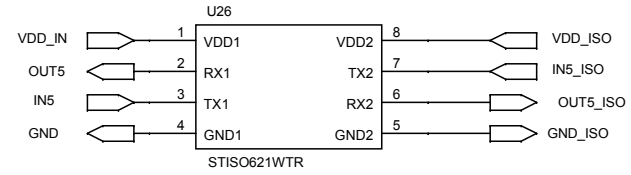
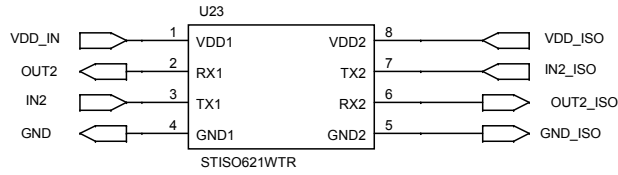
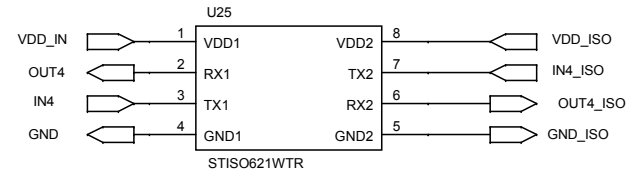
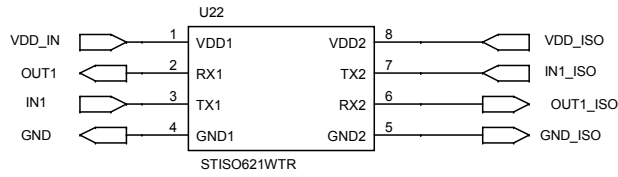

Figure 18. STEVAL-SILKTA01 circuit schematic (18 of 21)

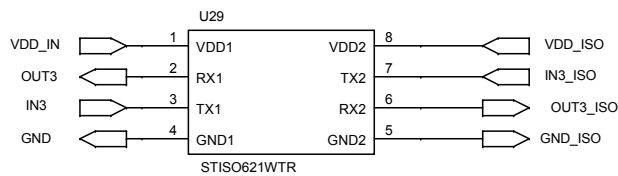
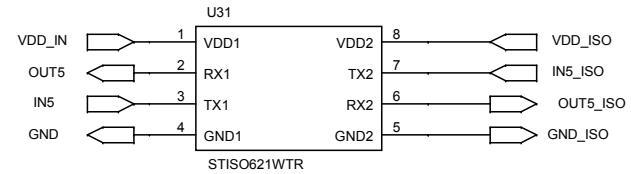
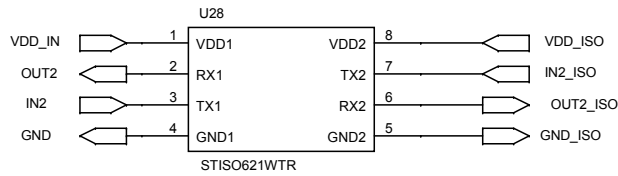
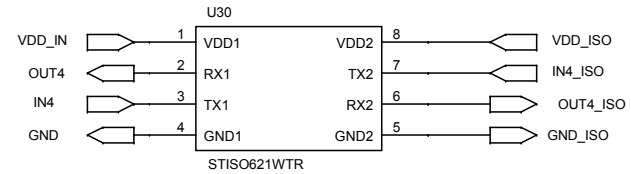
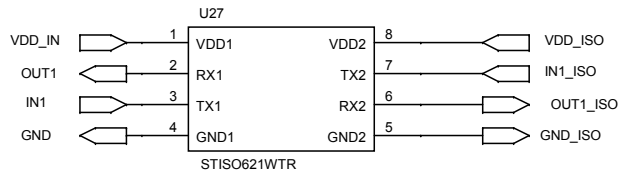

Figure 19. STEVAL-SILKTA01 circuit schematic (19 of 21)

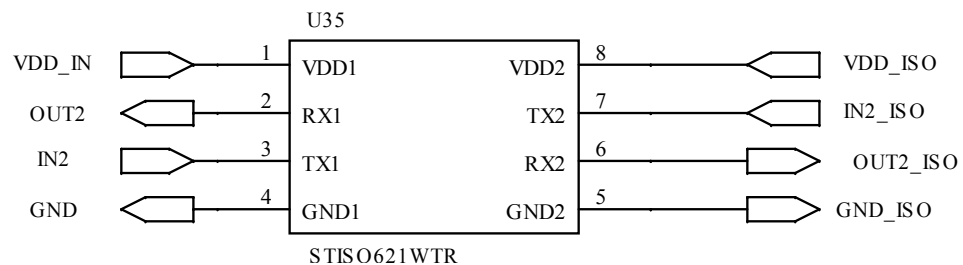
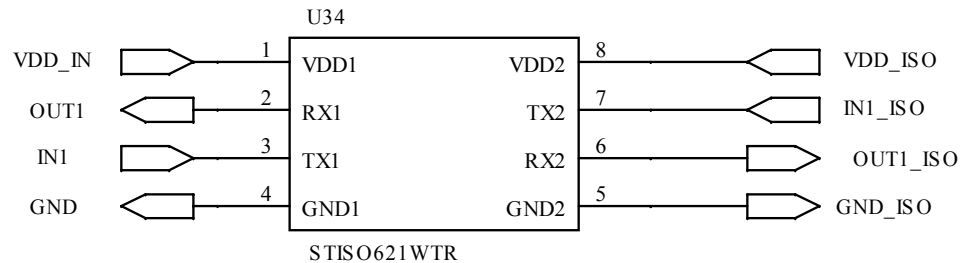

Figure 20. STEVAL-SILKTA01 circuit schematic (20 of 21)

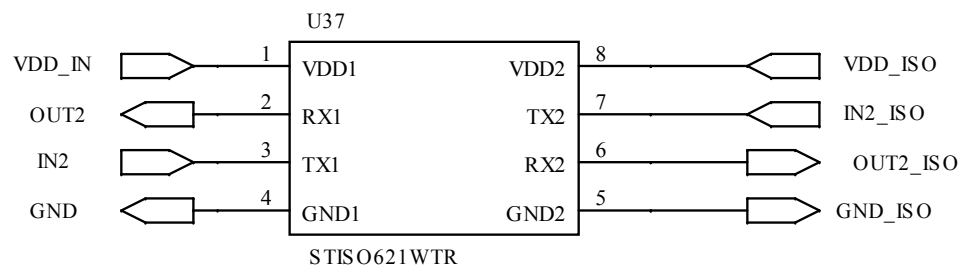
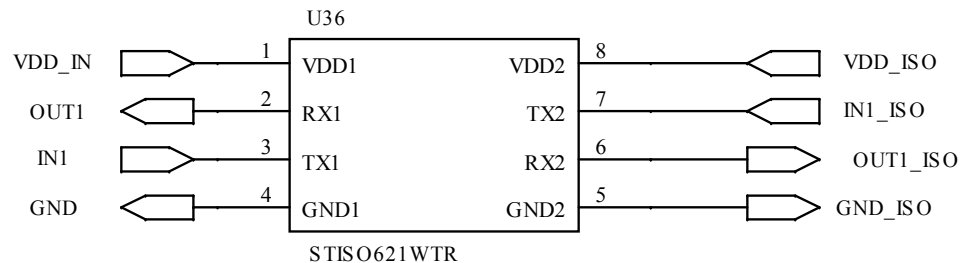



Figure 21. STEVAL-SILKTA01 circuit schematic (21 of 21)

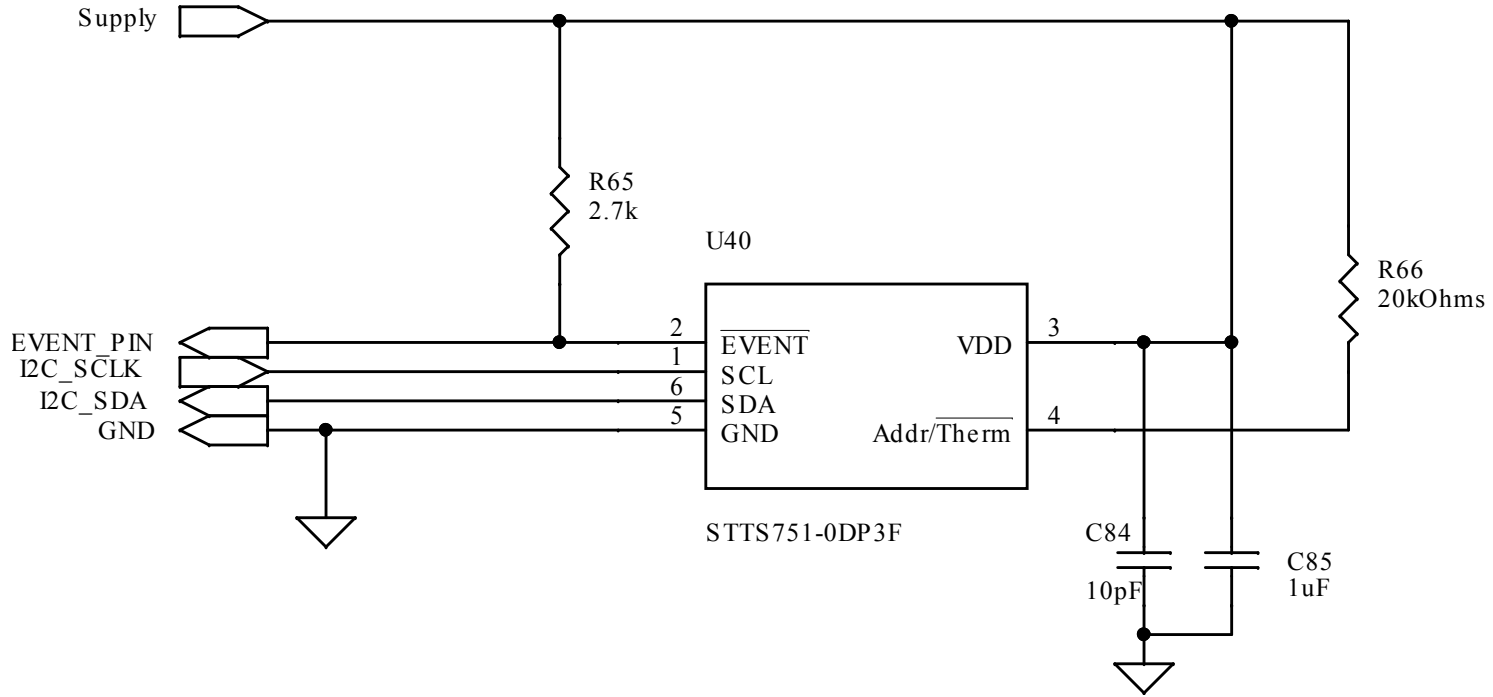

Figure 22. STEVAL-SILKTB01 circuit schematic (1 of 12)

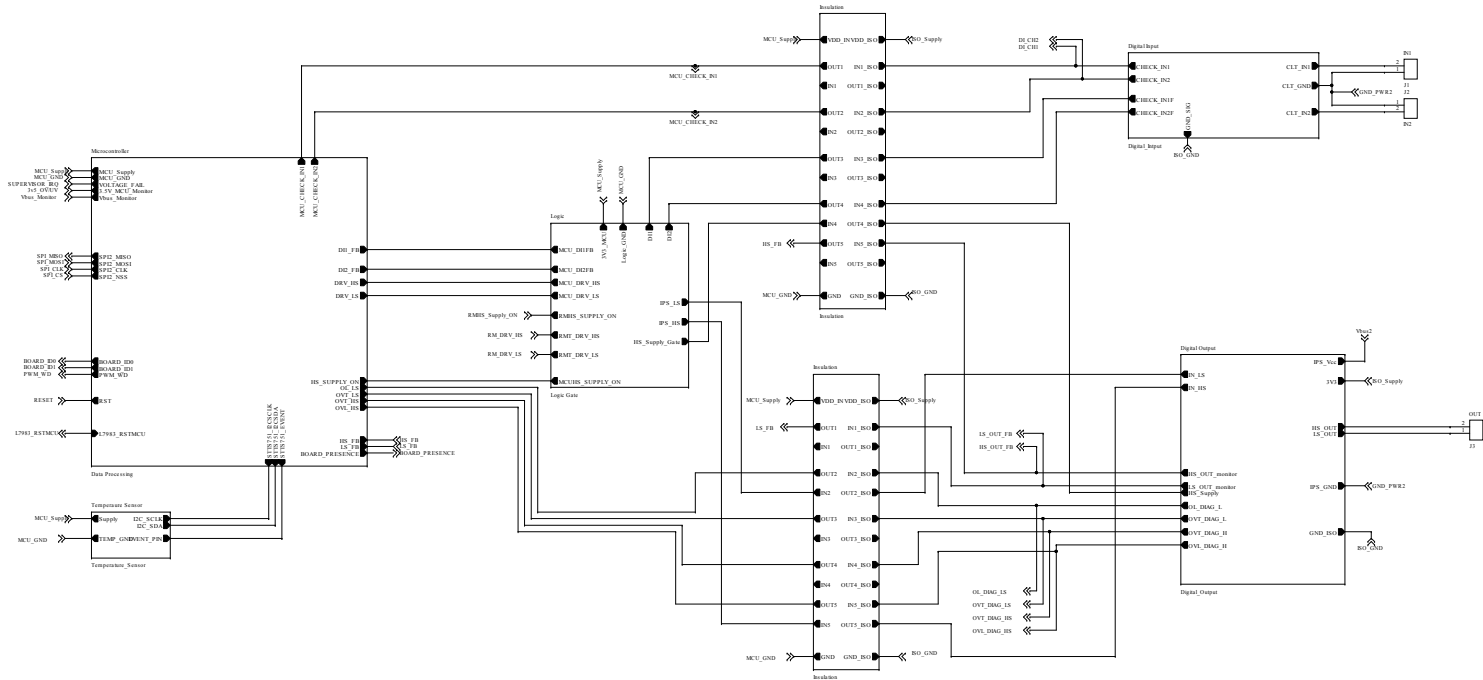

Figure 23. STEVAL-SILKTB01 circuit schematic (2 of 12)

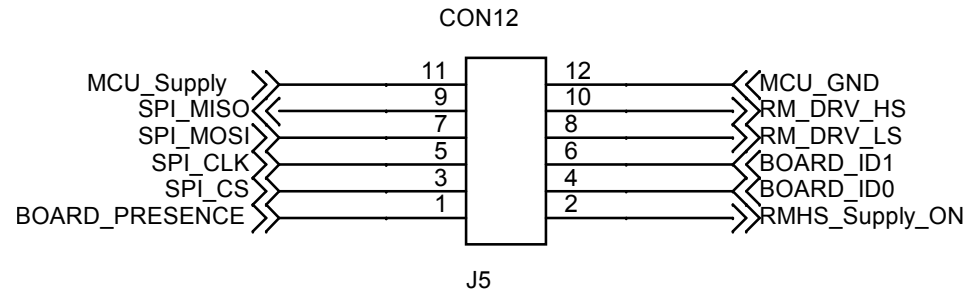
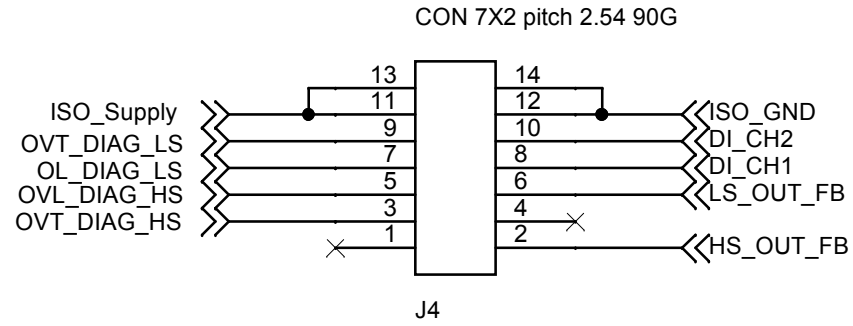

Figure 24. STEVAL-SILKTB01 circuit schematic (3 of 12)

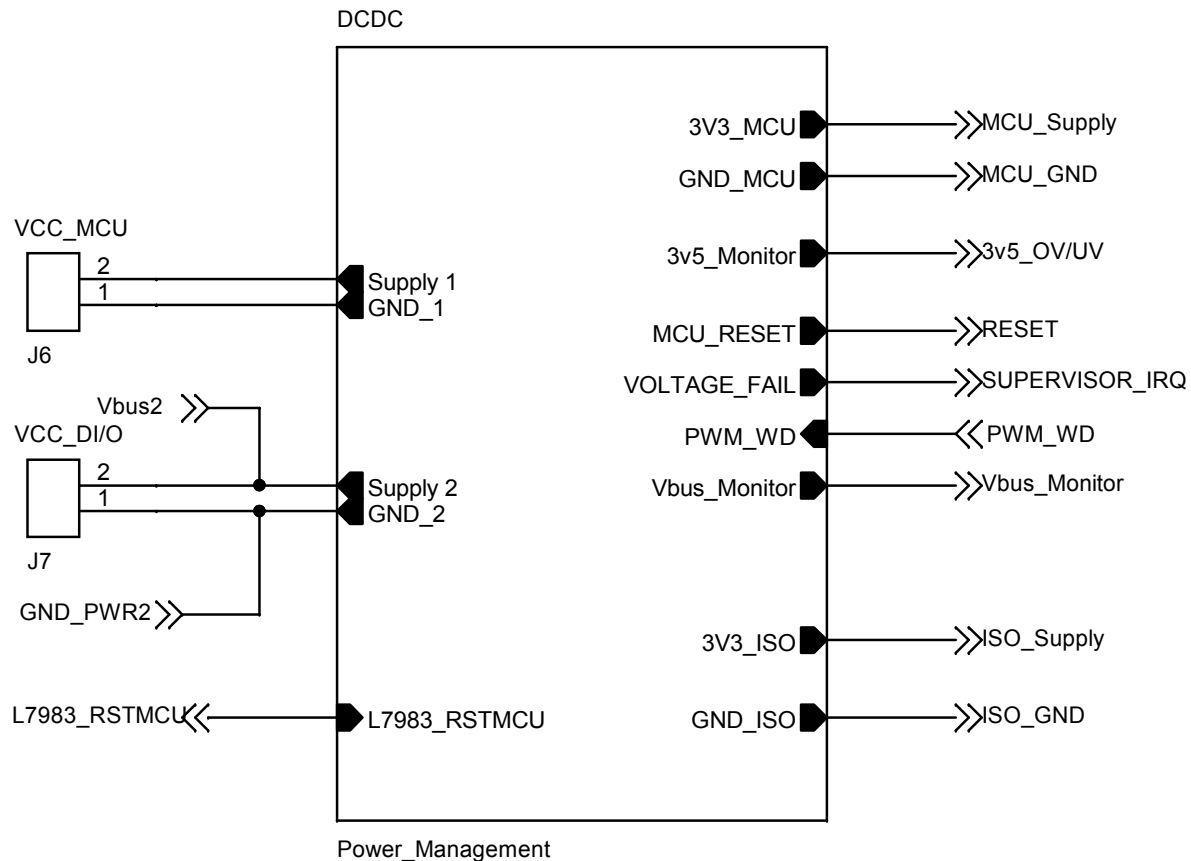

Figure 25. STEVAL-SILKTB01 circuit schematic (4 of 12)

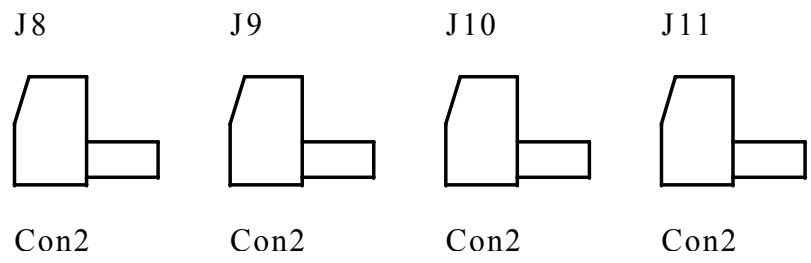

Figure 26. STEVAL-SILKTB01 circuit schematic (5 of 12)

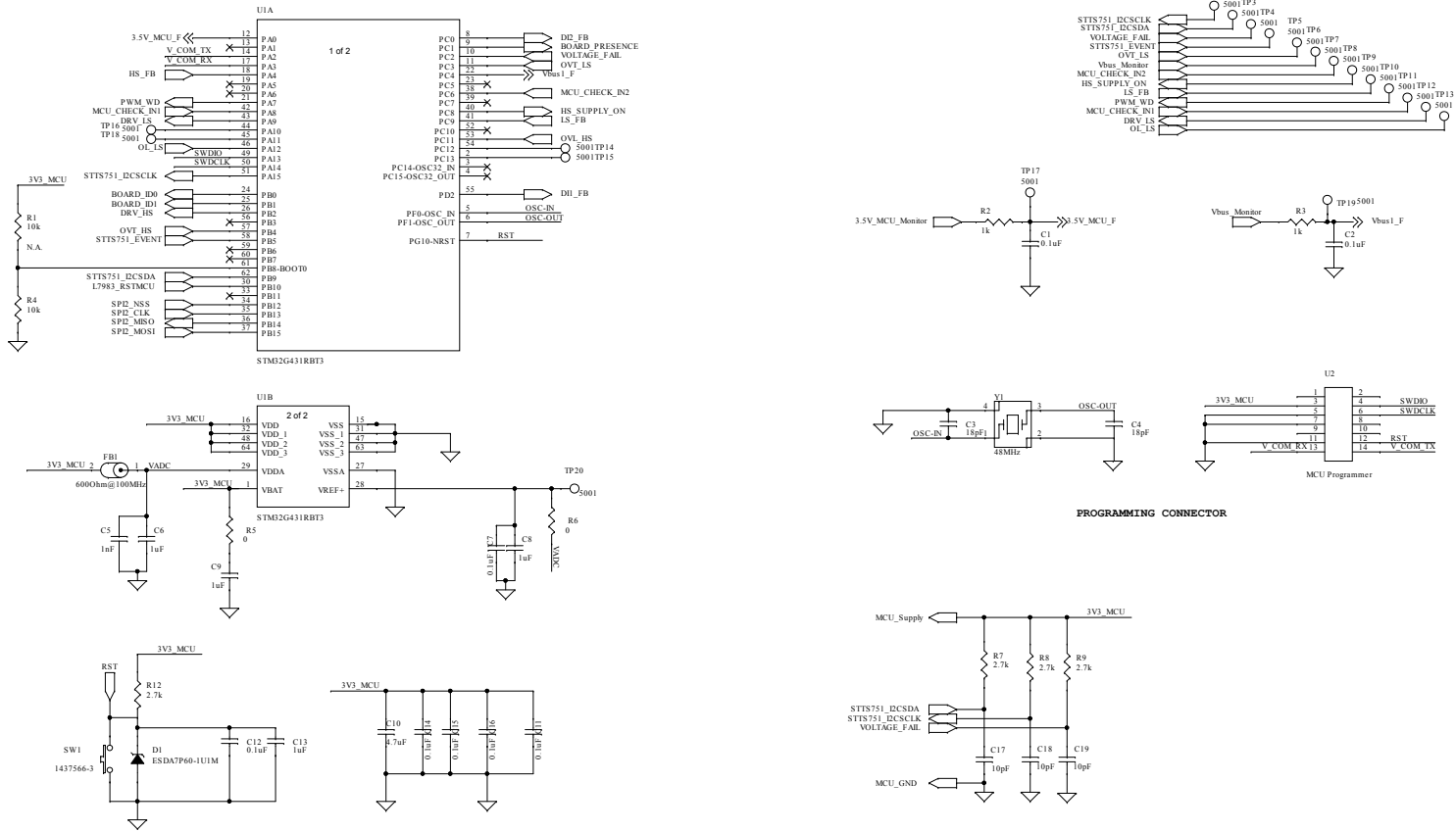

Figure 27. STEVAL-SILKTB01 circuit schematic (6 of 12)

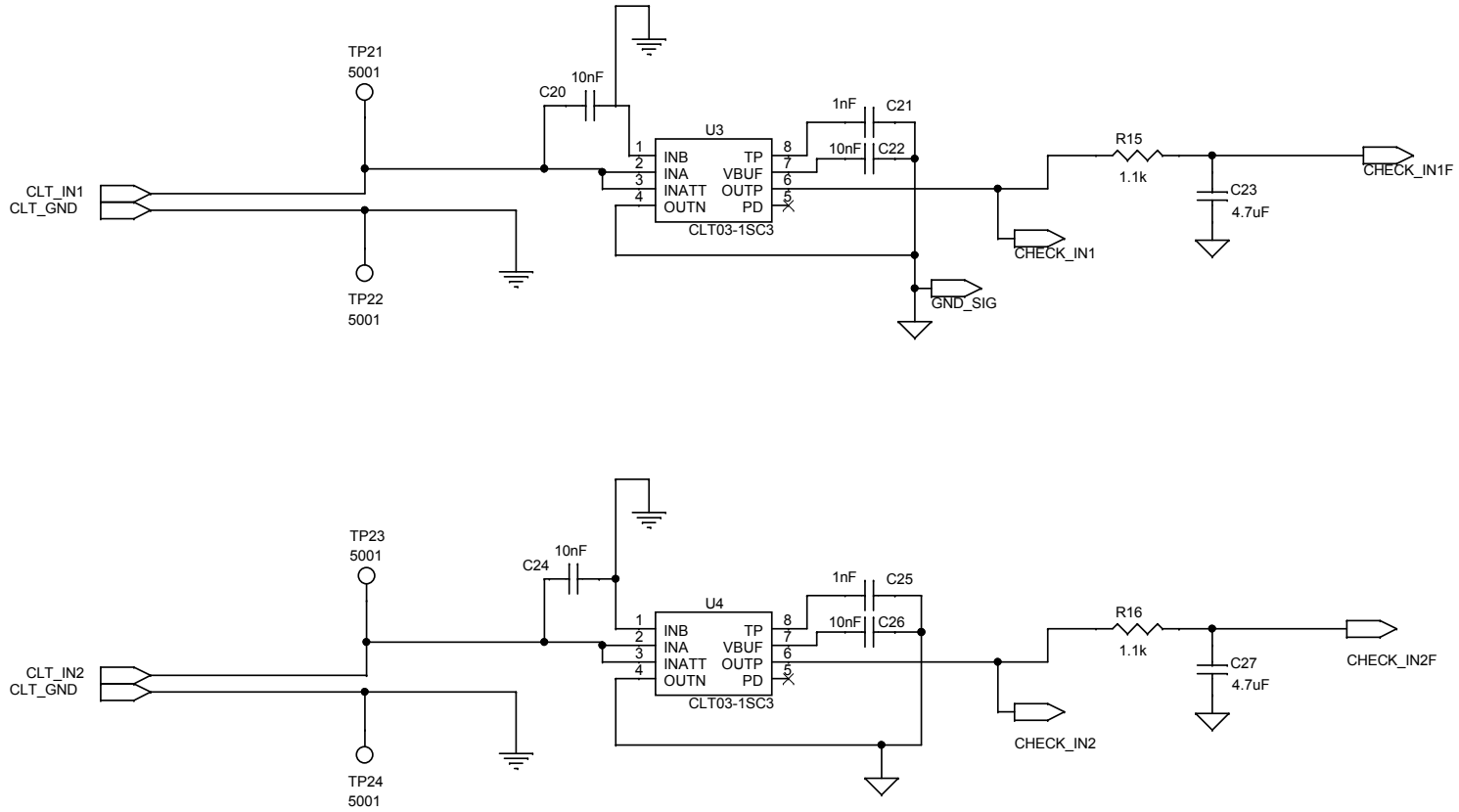

Figure 28. STEVAL-SILKTB01 circuit schematic (7 of 12)

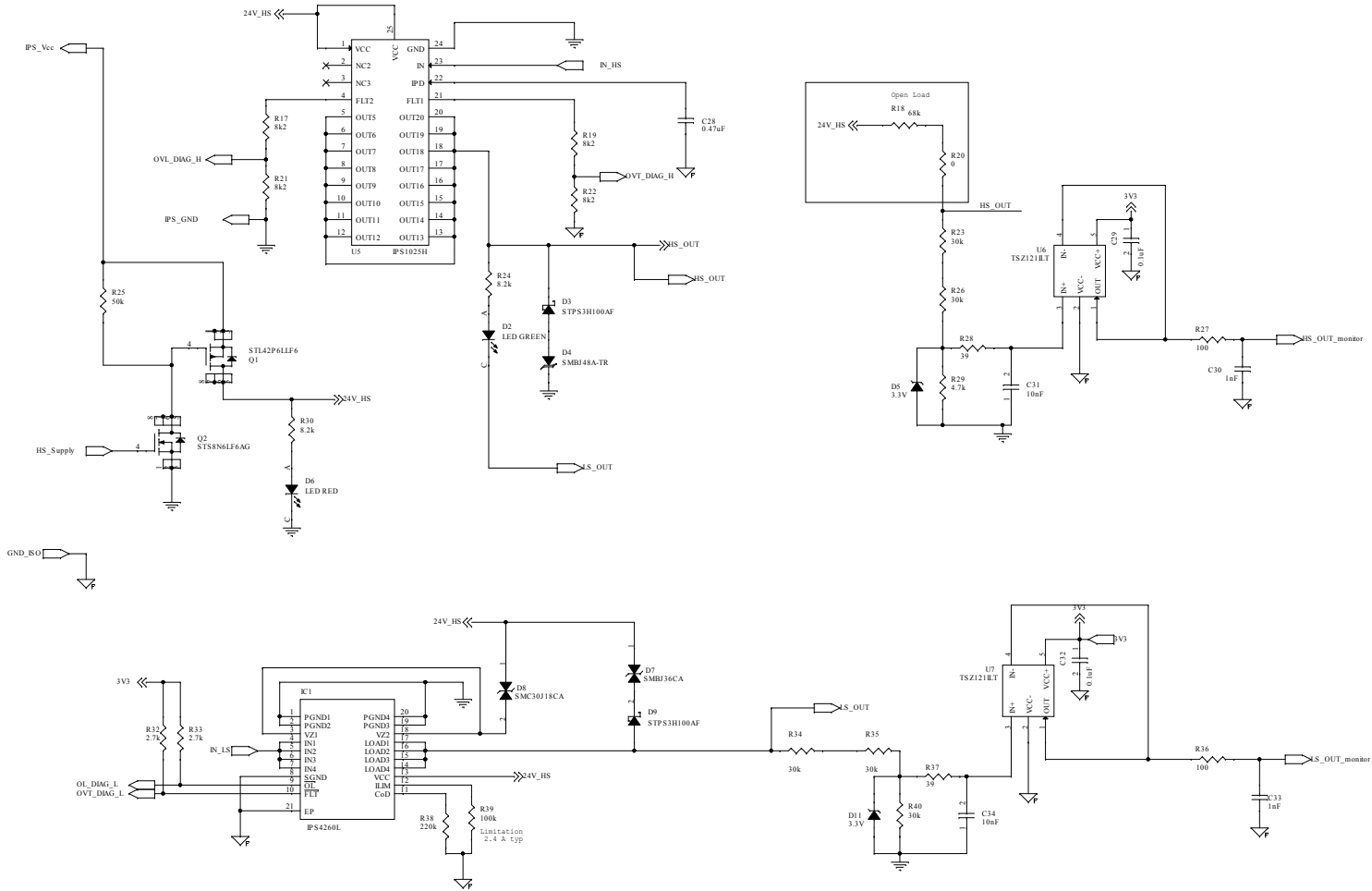

Figure 29. STEVAL-SILKTB01 circuit schematic (8 of 12)

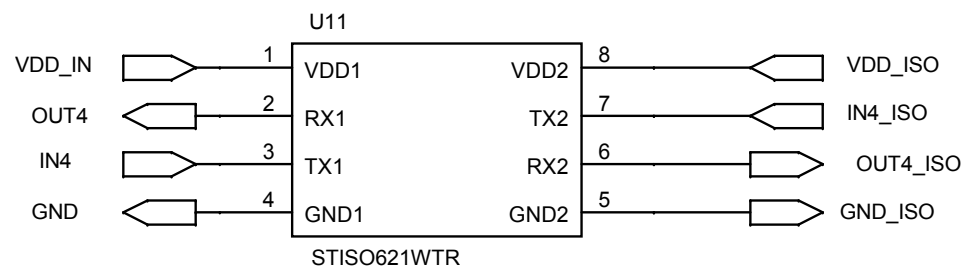
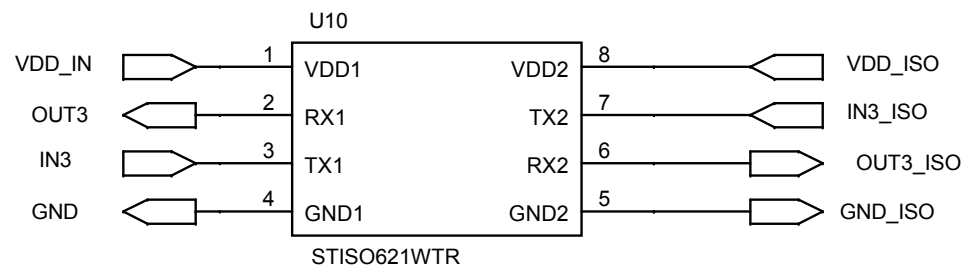
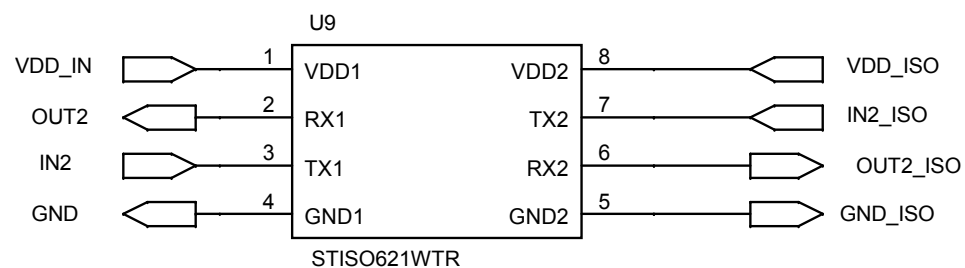
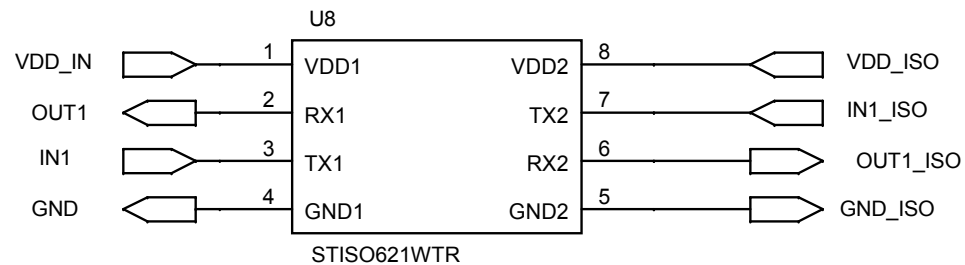
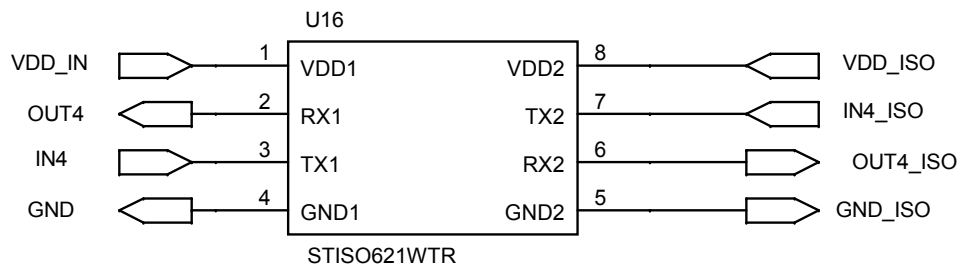
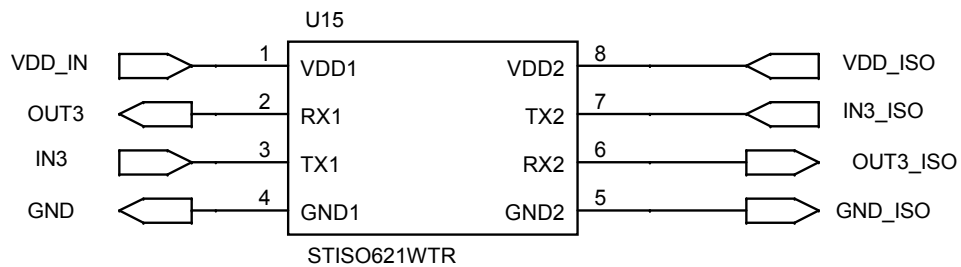
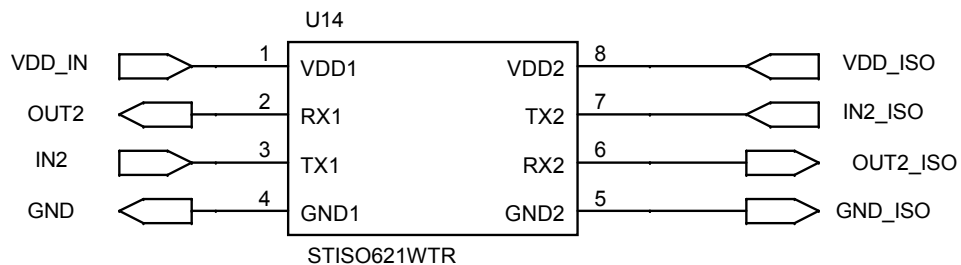
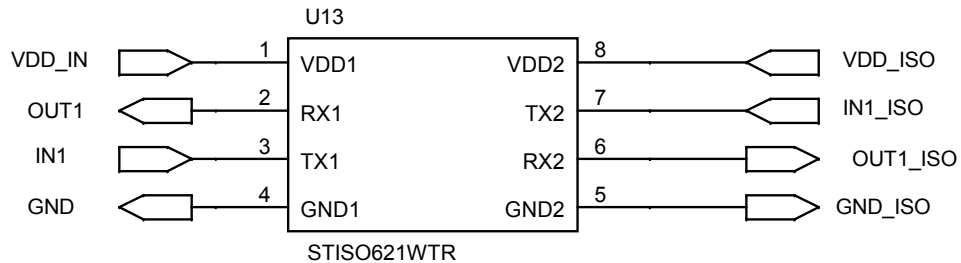



Figure 30. STEVAL-SILKTB01 circuit schematic (9 of 12)



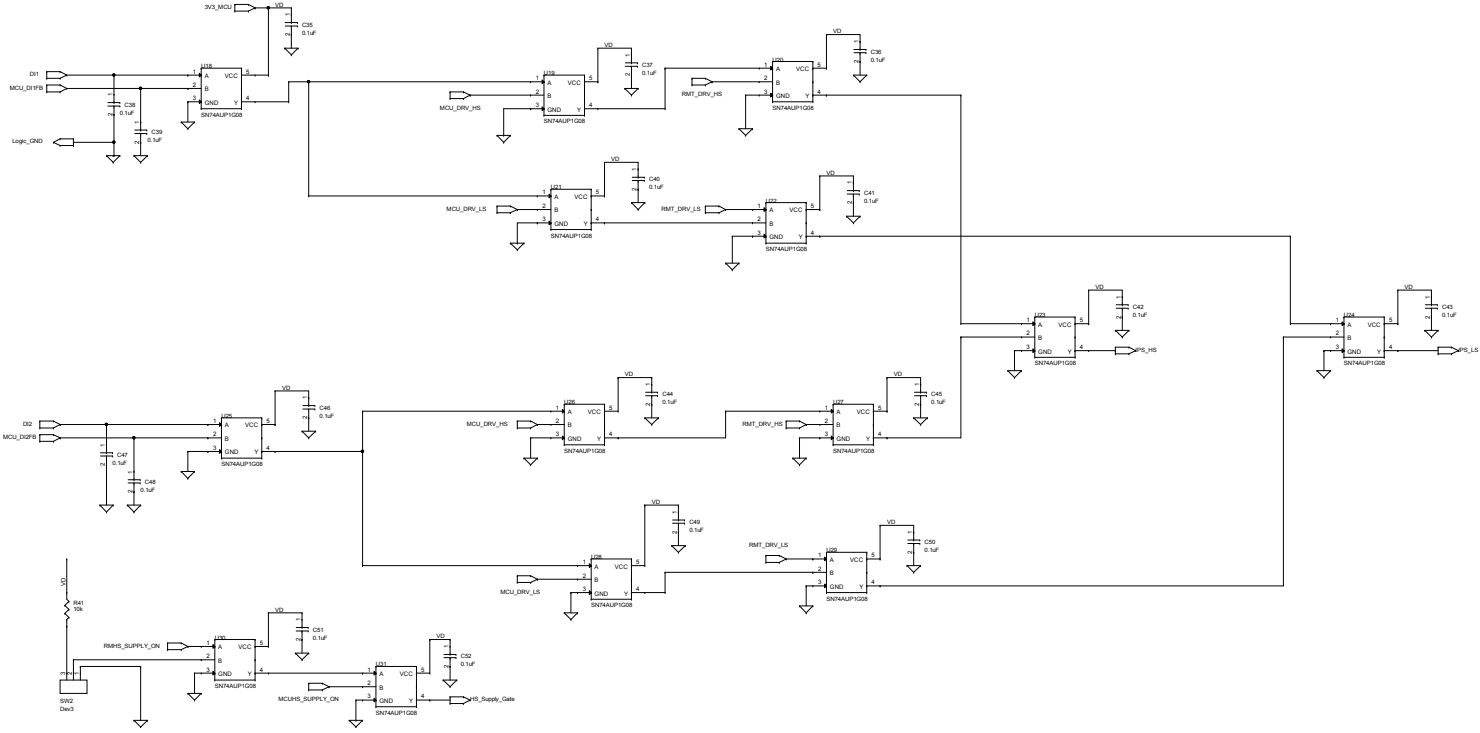

Figure 31. STEVAL-SILKT01 circuit schematic (10 of 12)



Figure 32. STEVAL-SILKTB01 circuit schematic (11 of 12)

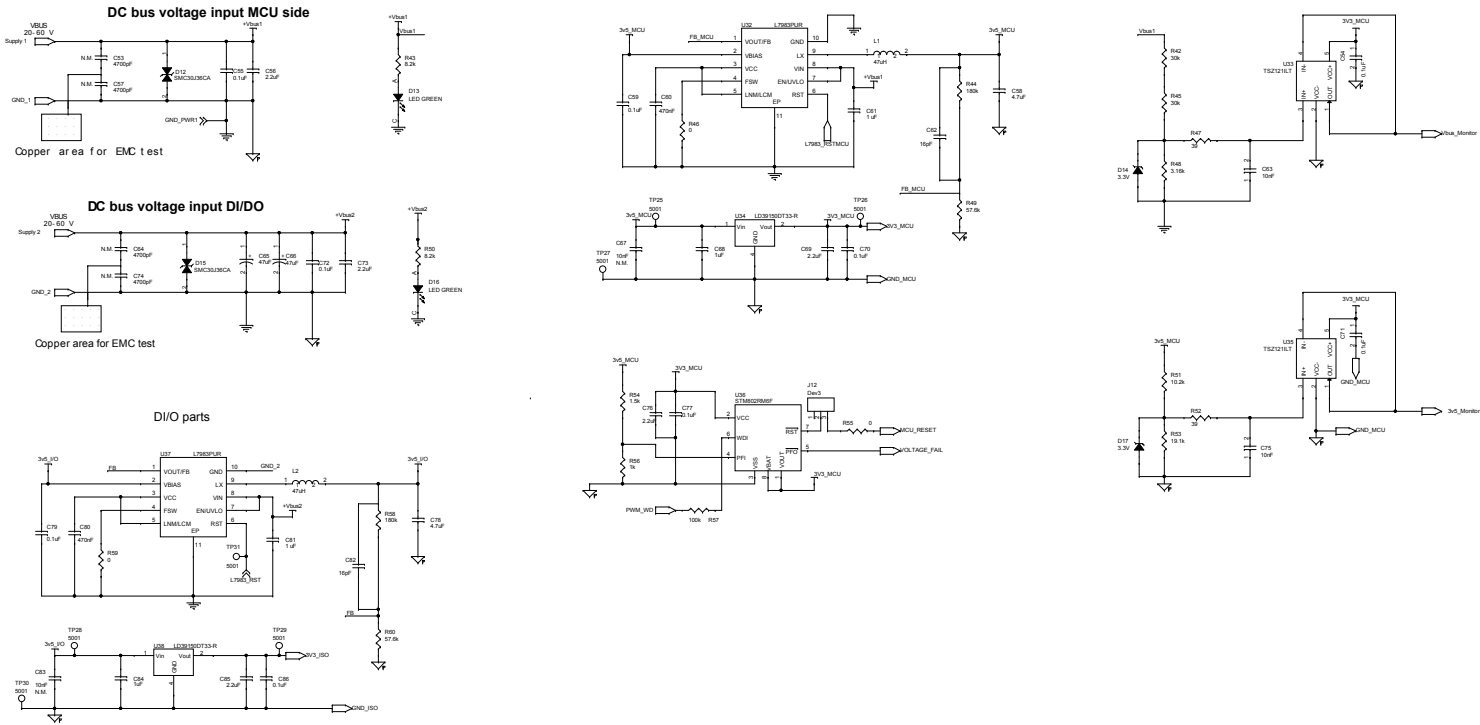
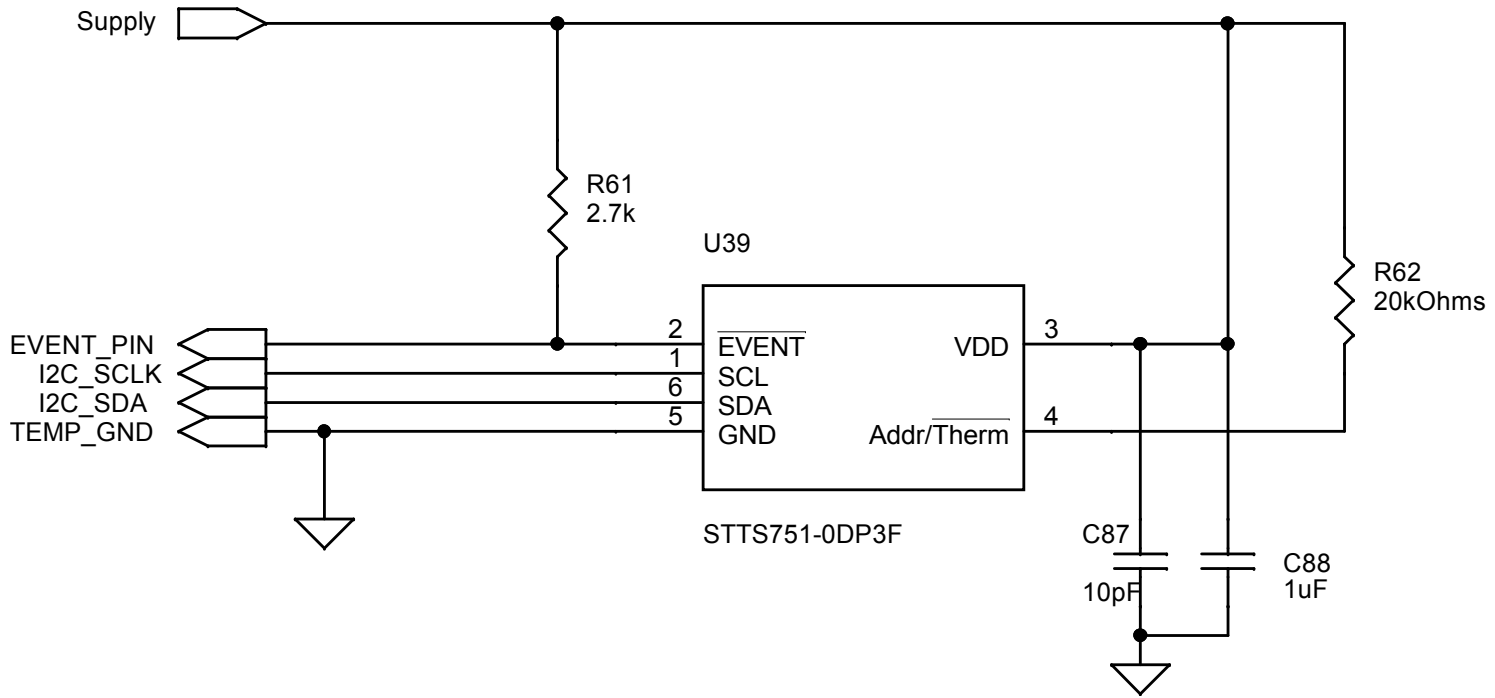

Figure 33. STEVAL-SILKTB01 circuit schematic (12 of 12)



### 3 Kit versions

**Table 1. STEVAL-SILKT01 versions**

PCB version	Schematic diagrams	Bill of materials
STEVAL\$SILKT01B <sup>(1)</sup>	STEVAL\$SILKT01B schematic diagrams	STEVAL\$SILKT01B bill of materials

- This code identifies the STEVAL-SILKT01 evaluation kit second version. The kit consists of the STEVAL-SILKTA01 main board whose version is identified by the code STEVAL\$SILKTA01A and two STEVAL-SILKTB01 actuation boards whose version is identified by the code STEVAL\$SILKTB01B.*

## Revision history

**Table 2. Document revision history**

Date	Revision	Changes
14-Dec-2023	1	Initial release.
26-Jun-2024	2	Updated <i>Figure 28. STEVAL-SILKTB01 circuit schematic (7 of 12)</i>
14-Nov-2024	3	Updated cover image, <a href="#">Section 2: Schematic diagrams</a> and <a href="#">Section 3: Kit versions</a> .

**IMPORTANT NOTICE – READ CAREFULLY**

STMicroelectronics NV and its subsidiaries (“ST”) reserve the right to make changes, corrections, enhancements, modifications, and improvements to ST products and/or to this document at any time without notice. Purchasers should obtain the latest relevant information on ST products before placing orders. ST products are sold pursuant to ST’s terms and conditions of sale in place at the time of order acknowledgment.

Purchasers are solely responsible for the choice, selection, and use of ST products and ST assumes no liability for application assistance or the design of purchasers’ products.

No license, express or implied, to any intellectual property right is granted by ST herein.

Resale of ST products with provisions different from the information set forth herein shall void any warranty granted by ST for such product.

ST and the ST logo are trademarks of ST. For additional information about ST trademarks, refer to [www.st.com/trademarks](http://www.st.com/trademarks). All other product or service names are the property of their respective owners.

Information in this document supersedes and replaces information previously supplied in any prior versions of this document.

© 2024 STMicroelectronics – All rights reserved