

SCARLET

Subboard Documentation

© **Fujitsu Microelectronics Europe GmbH**

Am Siebenstein 6-10
63303 Dreieich-Buchsschlag, Germany

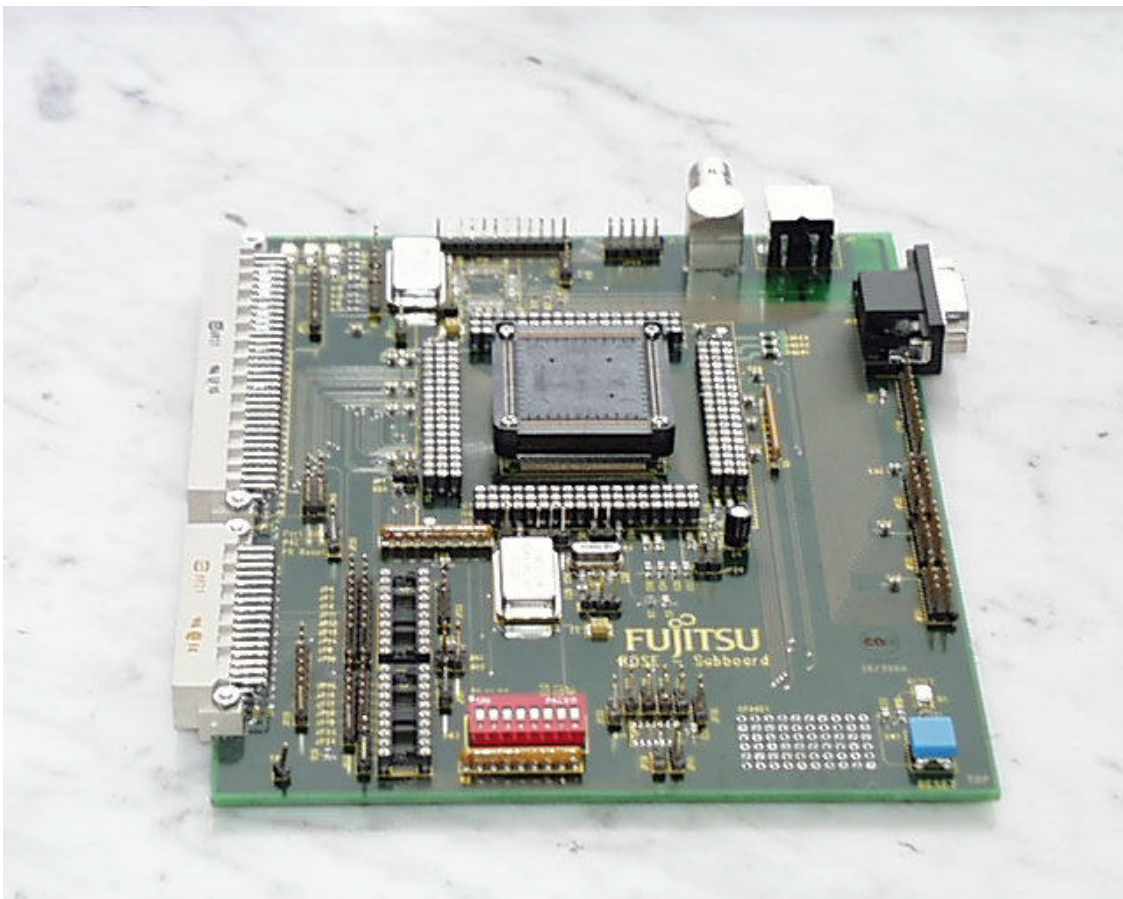

History

Revision	Date	Comment
V1.0	12.03.01	New Document
V1.1	06.06.01	Update (redesign of board)
V1.2	05.07.01	New board plan

Warranty and Disclaimer

To the maximum extent permitted by applicable law, Fujitsu Microelectronics Europe GmbH restricts its warranties and its liability for **all products delivered free of charge** (e.g. software include or header files, application examples, target boards, evaluation boards, engineering samples of IC's etc.), its performance and any consequential damages, on the use of the Product in accordance with (i) the terms of the License Agreement and the Sale and Purchase Agreement under which agreements the Product has been delivered, (ii) the technical descriptions and (iii) all accompanying written materials. In addition, to the maximum extent permitted by applicable law, Fujitsu Microelectronics Europe GmbH disclaims all warranties and liabilities for the performance of the Product and any consequential damages in cases of unauthorised decompiling and/or reverse engineering and/or disassembling. **Note, all these products are intended and must only be used in an evaluation laboratory environment.**

1. Fujitsu Microelectronics Europe GmbH warrants that the Product will perform substantially in accordance with the accompanying written materials for a period of 90 days from the date of receipt by the customer. Concerning the hardware components of the Product, Fujitsu Microelectronics Europe GmbH warrants that the Product will be free from defects in material and workmanship under use and service as specified in the accompanying written materials for a duration of 1 year from the date of receipt by the customer.
2. Should a Product turn out to be defect, Fujitsu Microelectronics Europe GmbH entire liability and the customer's exclusive remedy shall be, at Fujitsu Microelectronics Europe GmbH sole discretion, either return of the purchase price and the license fee, or replacement of the Product or parts thereof, if the Product is returned to Fujitsu Microelectronics Europe GmbH in original packing and without further defects resulting from the customer's use or the transport. However, this warranty is excluded if the defect has resulted from an accident not attributable to Fujitsu Microelectronics Europe GmbH, or abuse or misapplication attributable to the customer or any other third party not relating to Fujitsu Microelectronics Europe GmbH.
3. To the maximum extent permitted by applicable law Fujitsu Microelectronics Europe GmbH disclaims all other warranties, whether expressed or implied, in particular, but not limited to, warranties of merchantability and fitness for a particular purpose for which the Product is not designated.
4. To the maximum extent permitted by applicable law, Fujitsu Microelectronics Europe GmbH and its suppliers' liability is restricted to intention and gross negligence.

NO LIABILITY FOR CONSEQUENTIAL DAMAGES

To the maximum extent permitted by applicable law, in no event shall Fujitsu Microelectronics Europe GmbH and its suppliers be liable for any damages whatsoever (including but without limitation, consequential and/or indirect damages for personal injury, assets of substantial value, loss of profits, interruption of business operation, loss of information, or any other monetary or pecuniary loss) arising from the use of the Product.

Should one of the above stipulations be or become invalid and/or unenforceable, the remaining stipulations shall stay in full effect.

Important notice

This Starterkit contains an evaluation board, documentation and software on a CD-ROM.

For documentation or software updates, please refer to our web site www.fujitsu-fme.com !

Fujitsu reserves the right to make changes to its products or to discontinue any semiconductor product or service without notice.

12.03.01 V1.0

1. Introduction

The SCARLET-Subboard is a low cost multifunctional evaluation board for Fujitsu graphic device controller Scarlet. It can be used with CREMSON-Starterkit CPU-Modul for software development and testing as a simple target board.

The board allows the designer immediately to start the software development before his own final target system is available.

2. Features

- Graphic controller Scarlet in a package HQFP208
- 14.318 MHz crystal and 14.318 MHz oscillator
- Enhanced Video Input Processor (SAA7111A)
- Quarzoszilator for VIC
- Video input connector (BNC-90)
- 2 PALLV16V8
- a 74ALS1034 (six not inverted buffer)
- 3 LEDs for power supply
- Display interface (HD-DSUB-BU-15Pol)
- "CPU-Modul" interface
- Reset button for Scarlet

3. Jumpers and Switches

This chapter describes all jumpers and switches which can be modified on the evaluation board. The default setting is shown with a gray shaded area. All jumpers and switches are named directly on the board by its meaning, so it is very easy to set the jumpers according to the features.

3.1 Power Supply Voltage (JP1, JP2, JP4, JP20)

	Jumper setting	Description
3V3 power supply (JP1)	ON (closed)	Power supply
	OFF (open)	NO Power supply

	Jumper setting	Description
2V5 power supply (JP2)	ON (closed)	Power supply
	OFF (open)	NO Power supply

	Jumper setting	Description
2V5 power supply (JP4)	ON (closed)	Power supply
	OFF (open)	NO Power supply

	Jumper setting	Description
2V5 power supply (JP20)	ON (closed)	Analog Power supply
	OFF (open)	NO Analog Power supply

NOTE:

The supply voltage for the core and the IO Pins must be set. Otherwise it could happen that the controller does not work correctly!

3.2 Define graphic controller Operating Mode (SW3)

The Scarlet can be connected to Fujitsu FR30, Hitachi SH4(SH7750), SH3(SH7709/09A) and NEC V832. The host CPU type is specified by the MODE pins.

	CPU Type	SW3/Mode0	SW3/Mode1
Mode1-0	FR30/SH3	ON	ON
	SH4	OFF	ON
	V832	ON	OFF
	Reserved	OFF	OFF

	SW3/Mode2	Description
Mode2	ON	XRDY signal finished at low level
	OFF	XRDY signal finished at high level

	SW3/CKM	Description
Clock mode signal	ON	Output from internal PLL is selected
	OFF	Host CPU bus clock is selected

	SW3/EO	Description
Even/Odd signal mode	ON	Low level output in even frame, High level output in odd frame
	OFF	High level output in even frame, Low level output in odd frame

	Clock Input	SW3/CLKSEL0	SW3/CLKSEL1
Input Clock Selection	13.5 MHz	ON	ON
	14.32 MHz	OFF	ON
	17.73 MHz	ON	OFF
	Reserved	OFF	OFF

	SW3/OSCCNT	Description
Oscillator control	ON	Control of internal clock-module (should be H-level)
	OFF	

3.3 Reset Pin (JP29)

The Jumper JP29 determines the Scarlet Reset Pin. It can be connected directly with the Reset of the VGC, or with a port of the MCU, to execute a software Reset.

	JP29	Description
Reset	1-2	Reset from CPU-board
	2-3	Using port S0 from MCU

3.4 Video Input Processor (JP5, JP47, JP30)

	JP5	Description
Power supply voltage	On (closed)	Digital and analog supply voltage for VIC
	OFF (open)	NO power supply

	JP47	Description
VIC enable	1-2	VCC – VIC enable
	2-3	GND – VIC disable

	JP30	Description
I ² C-Bus slave address select	GND (closed)	0 = 48h for write, 49h for read
	VCC (open)	1 = 4Ah for write, 4Bh for read

	JP57	Description
I ² C-Serial data line (SDA)	1-2	Serial data line from MCU I ² C-Interface
	2-3	Serial data line from Scarlet I ² C-Interface

	JP27	Description
I ² C-Serial clock line (SCL)	1-2	Serial clock line from MCU I ² C-Interface
	2-3	Serial clock line from Scarlet I ² C-Interface

	JP58	Description
VIC signal	ON (closed)	Conclusion resistance 75 Ohm
	OFF (open)	More than 75 Ohm

3.5 Clock Settings (JP42, JP43, JP44)

	JP42	Description
Clock input enable	1-2	Scarlet clock from Oscillator Y1
	2-3	Scarlet clock from Crystal Y2

	JP43	Description
Crystal Y2	ON (closed)	Crystal enable
	OFF (open)	Crystal disable

	JP44	Description
PLL power supply	1-2	PLLVDV connect to core voltage
	2-3	PLLVDV connect to separated voltage

3.6 C-sync for display (JP5)

	JP5	Description
C-sync	ON (closed)	C-sync connected to VGA connector
	OFF (open)	C-sync not connected

3.7 PAL Settings (JP6, JP7, JP8, JP9, JP10, JP11, JP12, JP13, JP14, JP15, JP16, JP17, JP18, JP19, JP50, JP24)

	JP6	Description
Bus clock for PALLV16V8	ON (closed)	Needed for internal state machine
	OFF (open)	-

	JP7	Description
Wait request	ON (closed)	Wait request from Scarlet
	OFF (open)	-

	JP8	Description
Read strobe	ON (closed)	Read signal to Scarlet
	OFF (open)	-

	JP11	Description
Write strobe XWE0	ON (closed)	Write signal D0 – D7
	OFF (open)	-

	JP12	Description
Write strobe XWE1	ON (closed)	Write signal D8 – D15
	OFF (open)	-

	JP13	Description
Write strobe XWE2	ON (closed)	Write signal D16 – D23
	OFF (open)	-

	JP14	Description
Write strobe XWE3	ON (closed)	Write strobe D24 – D31
	OFF (open)	-

	JP9	Description
DMA acknowledge	ON (closed)	Not needed for internal logic
	OFF (open)	

	JP10	Description
DMA end operation	ON (closed)	Not needed for internal logic
	OFF (open)	

	JP15	Description
Bus clock for PALLV16V8	ON (closed)	Not needed for internal logic
	OFF (open)	

	JP16	Description
CS3	ON (closed)	CS3 for PAL logic enable
	OFF (open)	CS3 for PAL logic disable

	JP17	Description
CS4	ON (closed)	CS4 for PAL logic enable
	OFF (open)	CS4 for PAL logic disable

	JP18	Description
CS5	ON (closed)	CS5 for PAL logic enable
	OFF (open)	CS5 for PAL logic disable

	JP19	Description
CS6	ON (closed)	CS6 for PAL logic enable
	OFF (open)	CS6 for PAL logic disable

	JP50	Description
PAL Reset	ON (closed)	PAL Reset from VGC
	OFF (open)	-

	JP24	Description
Reset Switch	ON (closed)	Reset from switch SW1
	OFF (open)	-

3.7 Interrupt

	JP21 / JP52	Description
Interrupt enable	ON (closed)	Connected interrupt to MCU
	OFF (open)	-No connected

3.8 DMA

	JP23 / JP54	Description
DREQ0 enable	ON (closed)	Connected DREQ0 to MCU
	OFF (open)	-No connected

3.9 Header for Debug Signals

PWM (JP25)

- PortS7-1 - Free usable Port S (bit 1..7)

Display Signals (JP45)

- RTC0 - Real time control output
- RTS0 - PAL line identifier (SAA7111A)
- RTS1 - PAL line identifier (SAA7111A)
- V_{ref} - Vertical reference output signal
- H_{ref} - Horizontal reference output signal
- C_{ref} - Clock reference output
- HS - Horizontal sync output signal
- VS - Vertical sync output signal
- GPSW - General purpose switch output
- RES-out - Reset output (active low)

Power Supply Voltage (JP49)

- Power supply voltage (2V5, 3V3, 5V0) – GND

Video Input Processor Signals (JP84)

- SAA_VI7-0 - Digital Video Port Out-Bus from SAA7111A
- VI_CLK - Line-locked System Clock Output (27MHz) from SAA7111A

Chip Select Signals(JP28)

- CS0-6 - Chip Select from MCU

Buffer signals (JP34, JP35, JP36, JP37, JP38, JP39, JP40, JP41)

- I/O Pins for 74ALS1034 (six not inverted buffer)

Digital RED (JP31)

- R0-7 - Digital signal output (RED)

Digital GREEN (JP32)

- G0-7 - Digital signal output (GREEN)

Digital BLUE (JP33)

- B0-7 - Digital signal output (BLUE)

Analog Output (JP46)

- DCLK_OUT - Dot Clock Signal for Display
- DCLK_IN - Dot Clock Input for External Synchronization
- RED - Analog signal output (RED)
- GREEN - Analog signal output (GREEN)

- BLUE - Analog signal output (BLUE)
- H_SYNC - Horizontal sync signal output
- V_SYNC - Vertical sync signal output
- C_SYNC - Composite sync signal output
- GV - Video/Graphics Switch

PAL Output Pins (JH1, JH2, JP22, JP51, JP53)

- Not used in internal Logic

VIC Signal (JP59, JP60)

- Second connection for the video camera (video-in and camera GND)

For more information please look at the Hardware Manual of the Scarlet graphic controller, the Data Sheet of the Video Input Processor SAA7111A and the Data Sheet of the PALLV16V8.

4. Schematics and Drawings

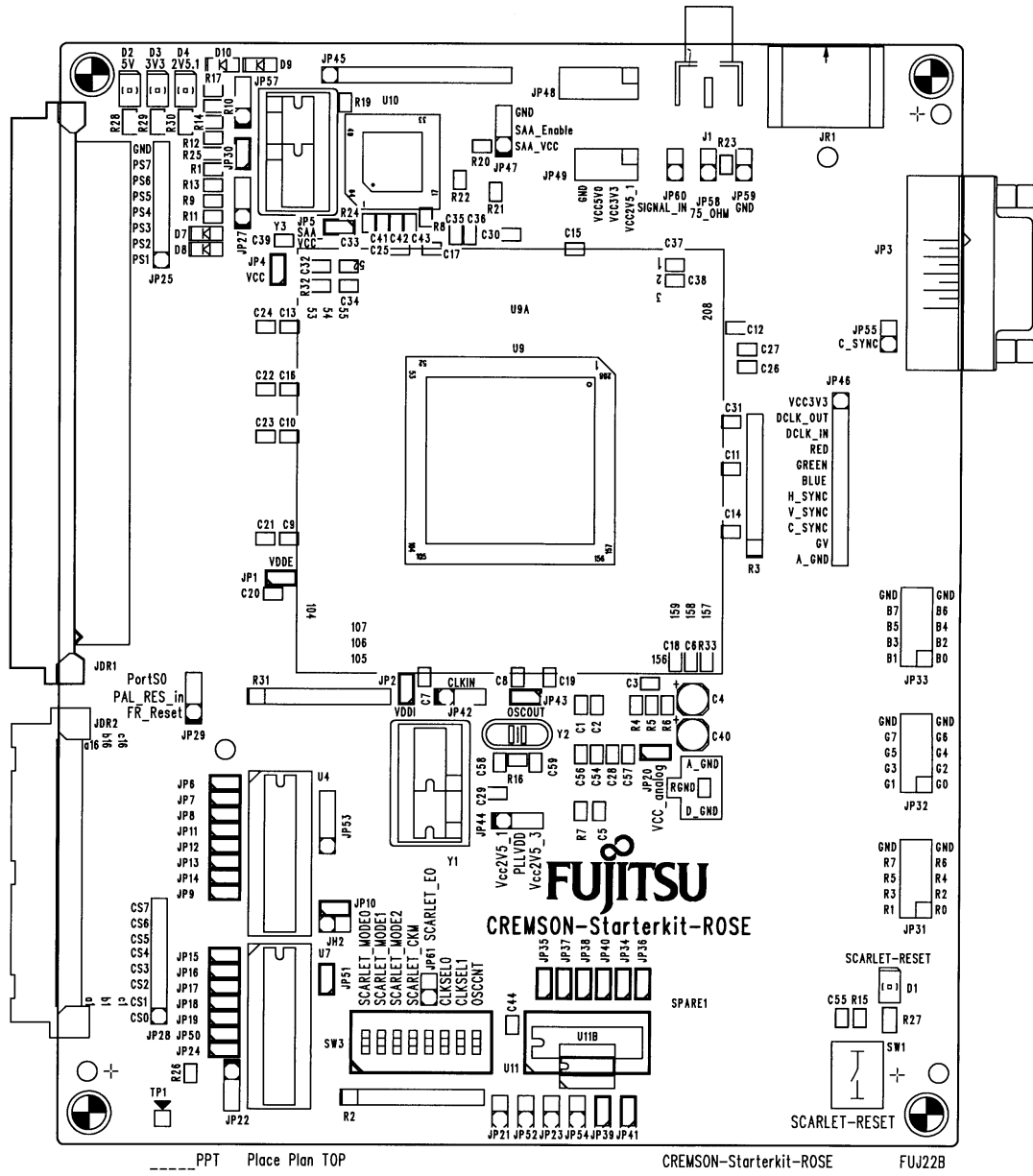

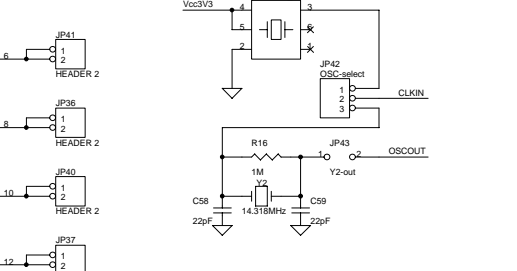
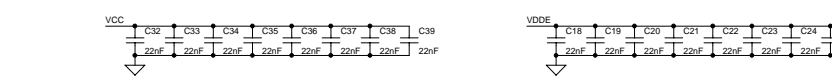
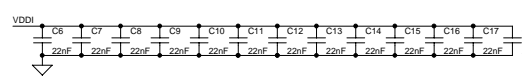
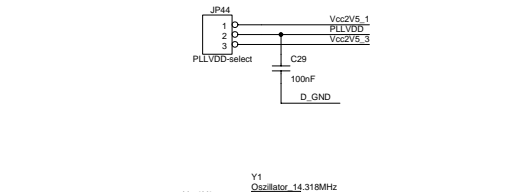
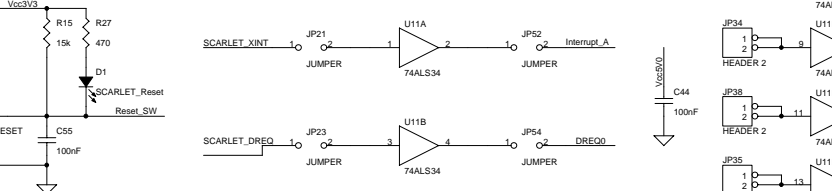
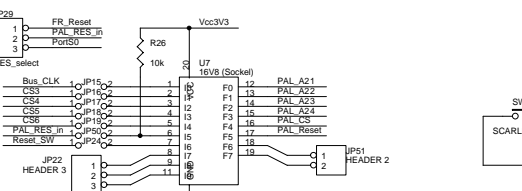
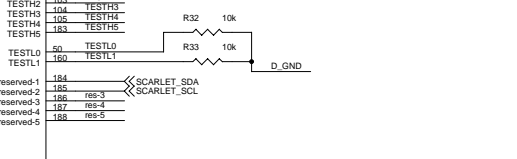
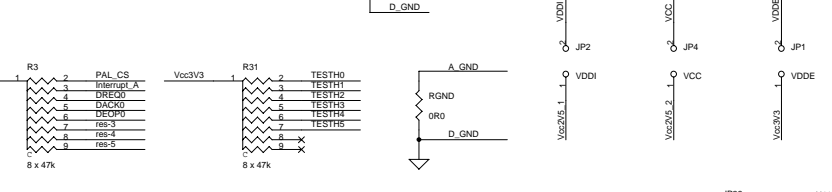
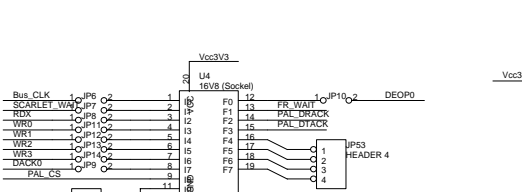
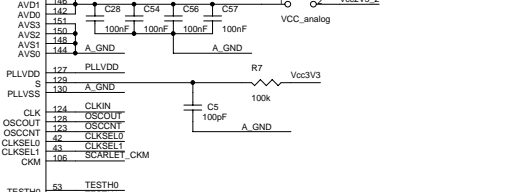
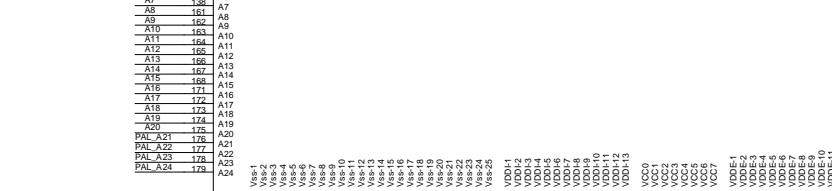
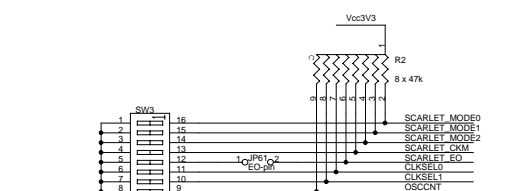
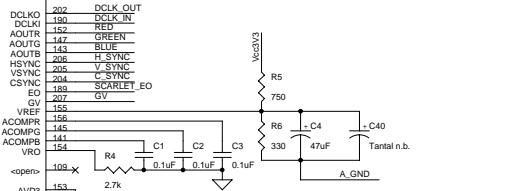
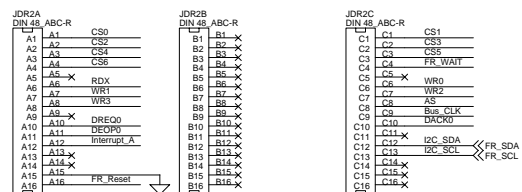
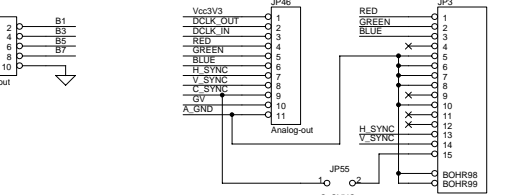
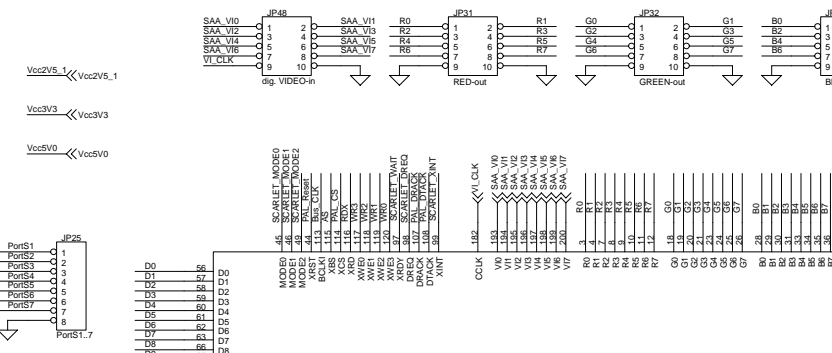
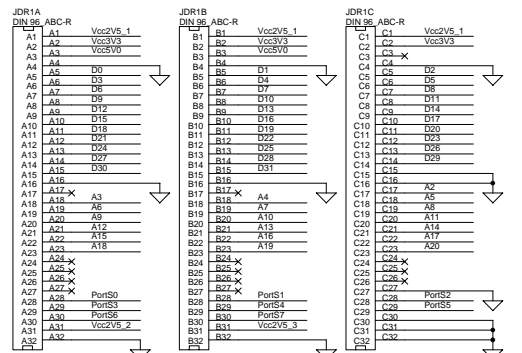

file	SCARLET-Subboard (CREMSON-Starterkit), FUJ22b		
Size	Document Number	SCARLET-Subboard / SCARLET	Rev 1.1
date	Thursday, April 05, 2001	Sheet	1 of 2

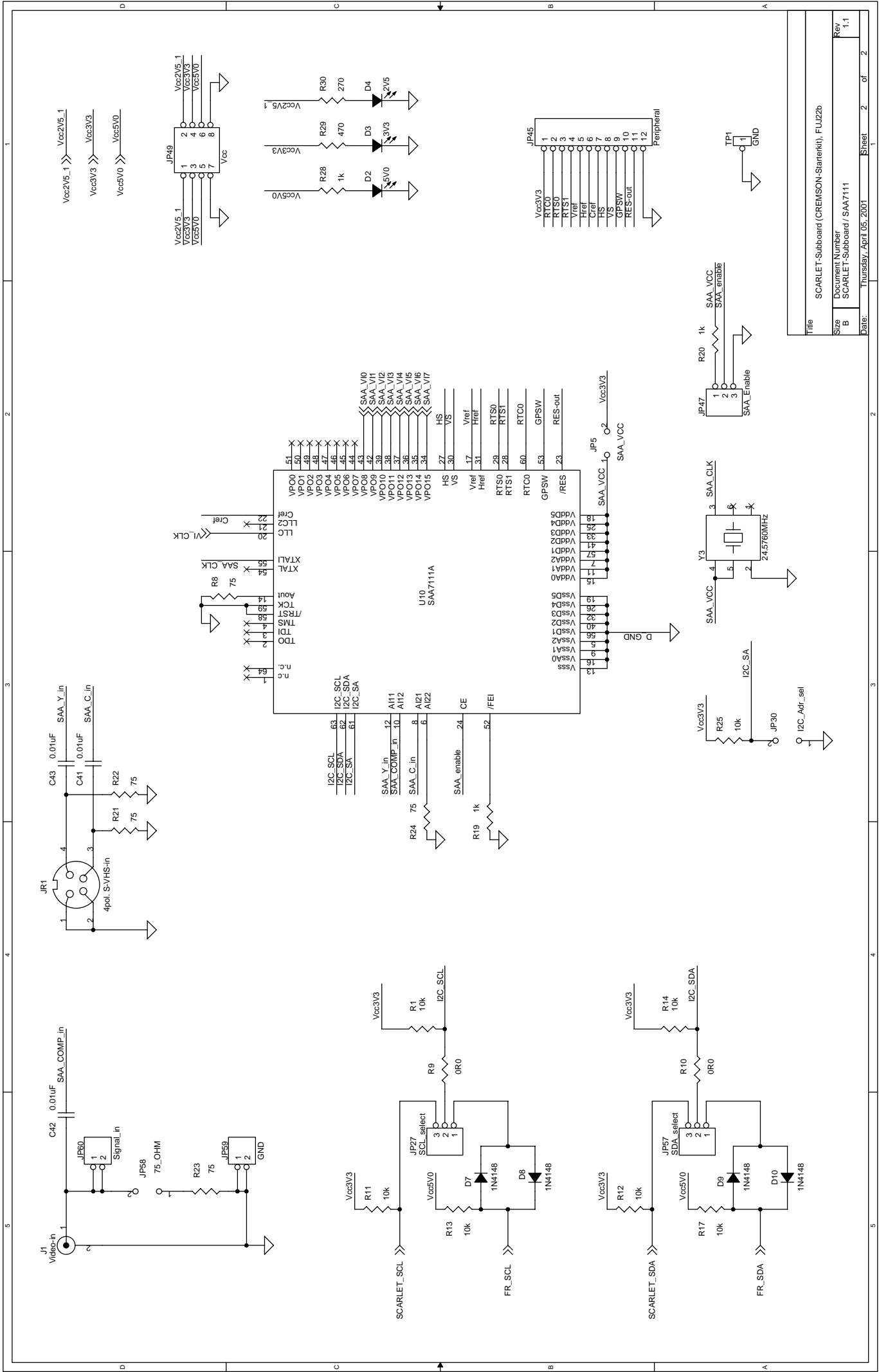

File		SCARLET-Subboard (CREMSON-Starterkit), FUJ22b	
Size	B	Document Number	SCARLET-Subboard / SAA7111
Date:	Thursday, April 05, 2001	Sheet	2 of 2
Rev	1, 1		