

## SDS Series

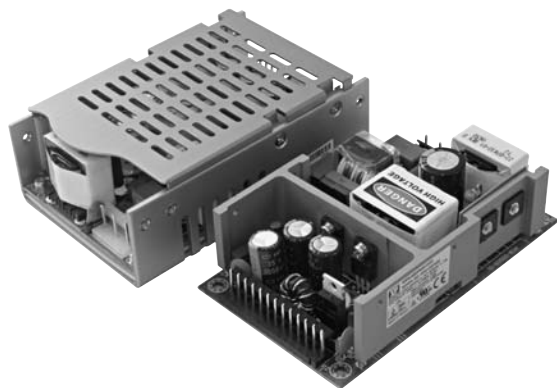

- Convection-cooled
- 3" x 5" Footprint
- Up to 90% Efficiency
- Open Frame, U-Channel & Covered Versions
- Low Temperature Option
- 150 W Medical Version
- 3 Year Warranty

## Specification

## Input

Input Voltage	• 90-260 VAC (120-370 VDC)
Input Frequency	• 47-63 Hz
Input Current	• 120 W: 1.7 / 1.0 A at 115 / 230 VAC 150 W: 2.0 / 0.8 A at 115 / 230 VAC 180 W: 2.7 A at 90 VAC
Inrush Current	• 120 W: 20 / 51 A at 115 / 230 VAC 150 W: 54 / 63 A at 115 / 230 VAC 180 W: 54 / 108 A at 115 / 230 VAC
Power Factor	• 0.97 typical
Earth Leakage Current	• 120 W: 0.30 / 0.75 mA at 115 / 230 VAC 150 W: 0.40 / 0.75 mA at 115 / 230 VAC 150 W (medical): 0.075 mA at 230 VAC 180 W: 0.75 mA at 230 VAC
Input Protection	• Internal T3.15 A / 250 VAC fuse
No Load Input Power	• 180 W: $\leq 0.5$ W

## Output

Output Voltage	• See table
Output Voltage Trim	• $\pm 5\%$ output 1 only (3.3 V variant $\pm 10\%$ ) SDS180: not user adjustable
Initial Set Accuracy	• Single output models: $\pm 1\%$ Multi-output models: $\pm 5\%$
Minimum Load	• No minimum load required for single output models. For multi-output models see table.
Start Up Delay	• 2 s max
Start Up Rise Time	• 2 ms typical
Hold Up Time	• 16 ms minimum at full load and 110 VAC
Line Regulation	• 0.5% typical
Load Regulation	• 3.0% typical
Transient Response	• 4% max deviation, recovery to within 1% in 500 $\mu$ s for a 50% load change
Ripple & Noise	• 1% pk-pk typical, 20 MHz bandwidth
Overvoltage Protection	• 112-132% V1 only, recycle input to reset
Overload Protection	• All outputs: 110-150% with auto recovery (primary power limit)
Short Circuit Protection	• Trip & restart (Hiccup mode), auto recovery
Temperature Coefficient	• $\pm 0.04\%/^{\circ}\text{C}$

## General

Efficiency	• 120 W: 80% typical 150 W and 180 W: 88% typical
Isolation	• 3000 VAC Input to Output 1500 VAC Input to Ground 500 VAC Output to Ground SDS150-M: 5600 VDC Input to Output 2800 VDC Input to Ground 500 VDC Output to Ground
Isolation Resistance	• 50 M $\Omega$
Switching Frequency	• 120 W: PFC 100 kHz typical, PWM 67 kHz typical 150 W: PFC 34 kHz minimum, PWM 55 kHz typical 180 W: PFC 67 kHz typical, PWM 67 kHz typical
Power Density	• 120 W: 4.87 W/In <sup>3</sup> , 150 W: 6.50 W/In <sup>3</sup> 180 W: 7.47 W/In <sup>3</sup>
Signals	• Power Fail Detect = TTL active low, combined AC and DC OK signal (option) Warning time 16 ms
MTBF	• >100 kHrs to MIL-HDBK-217F at 25 $^{\circ}\text{C}$ , GB

## Environmental

Operating Temperature	• 0 $^{\circ}\text{C}$ to +70 $^{\circ}\text{C}$ (-20 $^{\circ}\text{C}$ to +70 $^{\circ}\text{C}$ , SDS180), derate linearly from 100% load at +50 $^{\circ}\text{C}$ to 50% load at +70 $^{\circ}\text{C}$ , for low temperature option add suffix -L: -40 $^{\circ}\text{C}$ to +70 $^{\circ}\text{C}$ , SDS120 and SDS150, not available for SDS150-M and SDS180
Cooling	• Convection-cooled
Operating Humidity	• 5-95% RH, non-condensing
Storage Temperature	• -40 $^{\circ}\text{C}$ to +85 $^{\circ}\text{C}$

## EMC &amp; Safety

Emissions	• EN55022, CISPR22 level B conducted
Harmonic Currents	• EN61000-3-2, Class A
Voltage Flicker	• EN61000-3-3
ESD Immunity	• EN61000-4-2, level 2 Perf Criteria A
Radiated Immunity	• EN61000-4-3, 3 V/m Perf Criteria A
EFT/Burst	• EN61000-4-4, level 2 Perf Criteria A
Surge	• EN61000-4-5, level 3 Perf Criteria A
Conducted Immunity	• EN61000-4-6, level 2 Perf Criteria A
Dips & Interruptions	• EN61000-4-11, 30% 10 ms, 60% 100 ms, >95% 5000 ms Perf Criteria A, B, B
Safety Approvals	• EN60950-1, UL60950-1, CSA60950-1 per cUL

**Models and Ratings**

Max. Power	Output 1				Output 2				Output 3				Model Number <sup>(2,4,9)</sup>
	Vnom	Imin	Imax	Tol. <sup>(1)</sup>	Vnom	Imin	Imax	Tol. <sup>(1)</sup>	Vnom	Imin	Imax	Tol. <sup>(1)</sup>	
72.0 W	3.3 V	0.00 A	22.00 A	5%									SDS120PS03B†^
110.0 W	5.0 V	0.00 A	22.00 A	5%									SDS120PS05B†^
115.0 W	7.0 V	0.00 A	16.42 A	5%									SDS120PS07B
120.0 W	9.0 V	0.00 A	13.33 A	4%									SDS120PS09B
120.0 W	12.0 V	0.00 A	10.00 A	3%									SDS120PS12B†^
120.0 W	15.0 V	0.00 A	8.00 A	3%									SDS120PS15B†^
120.0 W	18.0 V	0.00 A	6.66 A	3%									SDS120PS18B
120.0 W	24.0 V	0.00 A	5.00 A	2%									SDS120PS24B†^
120.0 W	28.0 V	0.00 A	4.28 A	2%									SDS120PS28B†^
120.0 W	36.0 V	0.00 A	3.33 A	2%									SDS120PS36B
120.0 W	48.0 V	0.00 A	2.50 A	2%									SDS120PS48B†^
120.0 W	3.3 V	1.50 A	15.00 A	5%	12.0 V	0.20 A	6.0 A	5%					SDS120PD01B
120.0 W	5.0 V	1.50 A	15.00 A	5%	12.0 V	0.20 A	6.0 A	5%					SDS120PD02B
120.0 W	5.0 V	1.50 A	15.00 A	5%	15.0 V	0.20 A	6.0 A	5%					SDS120PD03B
120.0 W	5.0 V	1.50 A	15.00 A	5%	24.0 V	0.10 A	3.5 A	5%					SDS120PD04B
79.5 W	3.3 V	1.50 A	15.00 A	5%	5.0 V	0.40 A	6.0 A	5%					SDS120PD00B
120.0 W	5.0 V	1.50 A	15.00 A	5%	-24.0 V	0.20 A	2.0 A	5%					SDS120PD05B
120.0 W	28.0 V	0.39 A	3.92 A	5%	5.0 V	0.20 A	2.0 A	5%					SDS120PD06B
91.5 W	3.3 V	1.50 A	15.00 A	5%	5.0 V	0.60 A	6.0 A	5%	12.0 V	0.00 A	1.0 A	5%	SDS120PT00B†^
91.5 W	3.3 V	1.50 A	15.00 A	5%	5.0 V	0.60 A	6.0 A	5%	-12.0 V	0.00 A	1.0 A	5%	SDS120PT01B
120.0 W	3.3 V	1.50 A	15.00 A	5%	12.0 V	0.60 A	6.0 A	5%	5.0 V	0.00 A	0.8 A	5%	SDS120PT02B
120.0 W	3.3 V	1.50 A	15.00 A	5%	12.0 V	0.60 A	6.0 A	5%	-5.0 V	0.00 A	0.8 A	5%	SDS120PT03B
120.0 W	3.3 V	1.50 A	15.00 A	5%	12.0 V	0.60 A	6.0 A	5%	-12.0 V	0.00 A	0.8 A	5%	SDS120PT04B
120.0 W	3.3 V	1.50 A	15.00 A	5%	12.0 V	0.60 A	6.0 A	5%	12.0 V	0.00 A	0.8 A	5%	SDS120PT05B
120.0 W	5.0 V	1.50 A	15.00 A	5%	12.0 V	0.60 A	6.0 A	5%	5.0 V	0.00 A	0.8 A	5%	SDS120PT06B
120.0 W	5.0 V	1.50 A	15.00 A	5%	12.0 V	0.60 A	6.0 A	5%	-5.0 V	0.00 A	0.8 A	5%	SDS120PT07B†^
120.0 W	5.0 V	1.50 A	15.00 A	5%	12.0 V	0.60 A	6.0 A	5%	-12.0 V	0.00 A	0.8 A	5%	SDS120PT08B†^
120.0 W	5.0 V	1.50 A	15.00 A	5%	12.0 V	0.60 A	6.0 A	5%	12.0 V	0.00 A	0.8 A	5%	SDS120PT09B
120.0 W	5.0 V	1.50 A	15.00 A	5%	15.0 V	0.60 A	6.0 A	5%	-15.0 V	0.00 A	0.8 A	5%	SDS120PT10B†^
120.0 W	5.0 V	1.50 A	15.00 A	5%	15.0 V	0.60 A	6.0 A	5%	15.0 V	0.00 A	0.8 A	5%	SDS120PT11B
120.0 W	5.0 V	1.50 A	15.00 A	5%	24.0 V	0.35 A	3.5 A	5%	-24.0 V	0.00 A	0.8 A	5%	SDS120PT12B
120.0 W	5.0 V	1.50 A	15.00 A	5%	24.0 V	0.35 A	3.5 A	5%	24.0 V	0.00 A	0.8 A	5%	SDS120PT13B
120.0 W	5.0 V	1.50 A	15.00 A	5%	24.0 V	0.35 A	3.5 A	5%	-12.0 V	0.00 A	0.8 A	5%	SDS120PT14B
120.0 W	5.0 V	1.50 A	15.00 A	5%	24.0 V	0.35 A	3.5 A	5%	12.0 V	0.00 A	0.8 A	5%	SDS120PT15B†
120.0 W	5.0 V	1.50 A	15.00 A	5%	10.0 V	0.60 A	6.0 A	5%	-10.0 V	0.00 A	1.0 A	5%	SDS120PT16B
120.0 W	5.0 V	1.50 A	15.00 A	5%	10.0 V	0.60 A	6.0 A	5%	10.0 V	0.00 A	1.0 A	5%	SDS120PT17B

**Notes**

1. Total regulation includes line regulation and load regulation.
  2. For optional PCB only version, delete suffix 'B' from model number. Example SDS120PS03.
  3. For non-standard voltages contact sales.
- † Available from Farnell. See pages 266-269.

4. For optional low temperature -40 °C operation, add suffix '-L' to model number. Example: SDS120PS12B-L
  5. For optional Power Fail Detect circuit, add suffix '-P' to model number, example: SDS120PS12B-P
- ^ Available from Newark. See pages 270-272.

**Mechanical Details**

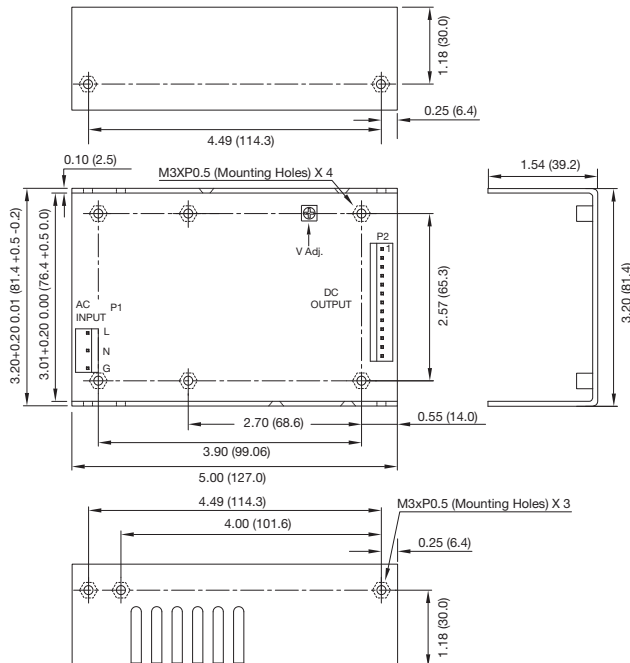

All dimensions are in inches (mm).  
 Weight: 0.77-0.99 lbs (350-450 g) approx.  
 For PCB-only version, overall dimensions are max 5.00 x 3.00 x 1.44 (127.0 x 76.2 x 36.6).

Pin	PIN CONNECTIONS		
	Single	Dual	Triple
1	V1	V2	V2
2	V1	V2	V2
3	V1	V1	V1
4	V1	V1	V1
5	V1	V1	V1
6	V1	V1	V1
7	Return	Common	Common
8	Return	Common	Common
9	Return	Common	Common
10	Return	N/C	V3
11	Return	Common	Common
12	Return	Common	Common
13	PFD <sup>(1)</sup>	PFD <sup>(1)</sup>	PFD <sup>(1)</sup>

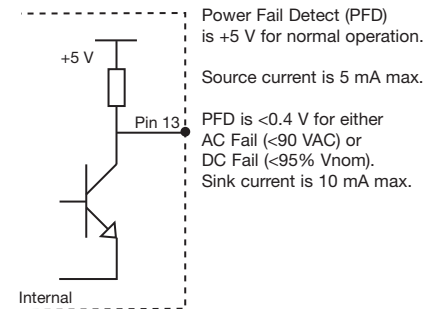

**Notes:**

1. Optional Power Fail Detect signal on 'P' versions only. Standard models pin 13 is N/C.
2. I/P connector P1 mates with Molex housing 09-50-3051 & Molex 2878 series crimp terminal.
3. O/P P2 mates with Molex housing 09-50-3131 & Molex 2878 series crimp terminal.
4. For optional cover kit order part number SDS120 COVER†^, to receive unit with cover fitted add suffix 'C' to model number (overall height is 1.73 (44.0)).
5. For mating connector kit order part number SDS120 CON KIT†.
6. For cable harness order part number SDS120S LOOM† for single output models & SDS120M LOOM† for multi-output models.
7. Maximum mounting screw penetration: 0.16 (4.0)



Maximum Output Power	Output Voltage	Output Current		Total Regulation <sup>(1)</sup>	Model Number <sup>(2,4,5,6)</sup>
		Minimum	Maximum		
144 W	9 V	0 A	16.00 A	5%	SDS150PS09B†^
150 W	12 V	0 A	12.50 A	5%	SDS150PS12B†^
150 W	15 V	0 A	10.00 A	5%	SDS150PS15B†^
150 W	18 V	0 A	8.33 A	4%	SDS150PS18B†^
150 W	24 V	0 A	6.25 A	3%	SDS150PS24B†^
150 W	30 V	0 A	5.00 A	2%	SDS150PS30B
150 W	36 V	0 A	4.17 A	2%	SDS150PS36B
150 W	48 V	0 A	3.13 A	2%	SDS150PS48B†^

**Notes**

1. Total regulation includes line regulation and load regulation.
2. For optional 2 pin Molex input, add suffix '-D' to model number. Example SDS150PS12B-D.
3. For non-standard voltages contact sales.
4. For optional low temperature -40 °C operation, add suffix '-L' to model number. Example: SDS150PS12B-L
5. For optional PCB only version, delete suffix 'B' from model number. Example SDS150PS48.
6. For optional Power Fail Detect signal (PFD), add suffix '-P' to model number. Example: SDS150PS48B-P.

† Available from Farnell. See pages 266-269.

^ Available from Newark. See pages 270-272.

**Mechanical Details**

**U Channel**

Weight: 1.27 lbs (580 g) approx.

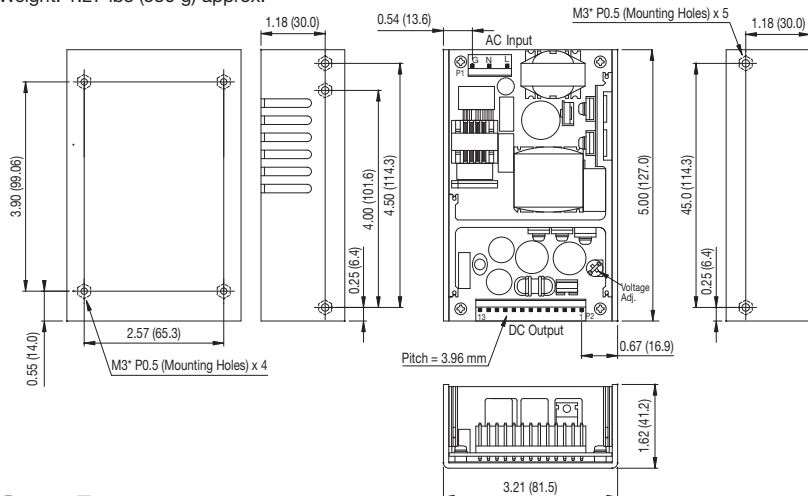

P2 - PIN CONNECTIONS			
Pin	Function	Pin	Function
1	V1	7	Return
2	V1	8	Return
3	V1	9	Return
4	V1	10	Return
5	V1	11	Return
6	V1	12	Return
		13	PFD <sup>(4)</sup>

**Notes:**

1. Dimensions in inches (mm), tolerance ±0.02 (±0.5).
2. Input connector P1 mates with Molex housing 09-50-3051 and Molex 2478 series crimp terminal.
3. Output connector P2 mates with Molex housing 09-50-3131 and Molex 2478 series crimp terminal.
4. Optional power fail detect signal on 'P' versions only. Standard models pin 13 is not connected.
5. For mating connector kit order part number SDS150 CON KIT.
6. For cable harness order part number SDS150 LOOM.
7. Maximum mounting screw penetration: 0.16 (4.0)

**Open Frame**

Weight: 0.86 lbs (390 g) approx.

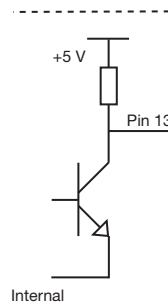
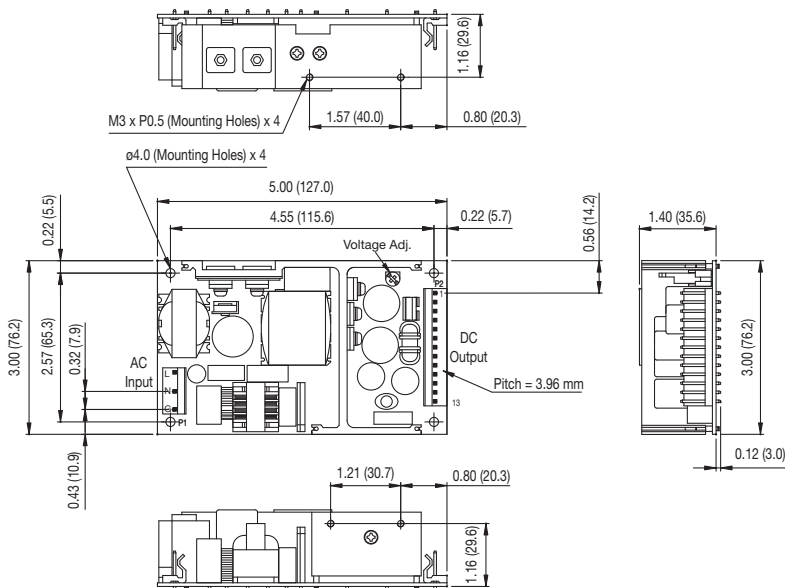

Power Fail Detect (PFD) is +5 V for normal operation. Source current is 5 mA max. PFD is <0.4 V for either AC Fail (<90 VAC) or DC Fail (<95% Vnom). Sink current is 10 mA max.

## Models and Ratings - 150 W Medical

**SDS150-M XP**

Maximum Output Power	Output Voltage	Output Current		Total Regulation <sup>(1)</sup>	Model Number <sup>(3,4)</sup>
		Minimum	Maximum		
150 W	12 V	0 A	12.5 A	5%	SDS150PS12-M
150 W	24 V	0 A	6.25 A	5%	SDS150PS24-M

### Notes

1. Total regulation includes line regulation and load regulation.
2. For non-standard voltages contact sales.
3. For optional U-Channel version 5.0 x 3.21" (127.0 x 81.5 mm) add suffix 'B' to part number. Example SDS150PS12B-M.

4. For optional 2 pin Molex input, add suffix '-D' to model number. Example SDS150PS12-MD.

## Mechanical Details

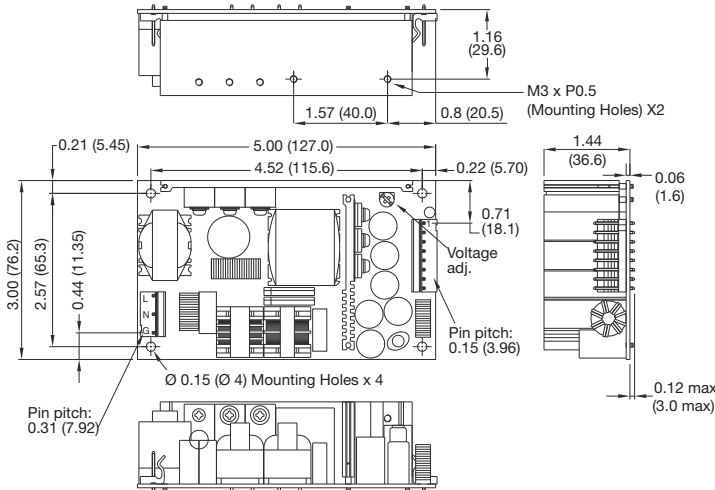

P2 - PIN CONNECTIONS			
Pin	Function	Pin	Function
1	V1	5	Return
2	V1	6	Return
3	V1	7	Return
4	V1	8	Return

### Notes:

1. Dimensions in inches (mm), tolerance  $\pm 0.02$  ( $\pm 0.5$ ).
2. Weight: 0.66 lbs (300 g)
3. Input connector P1 mates with Molex housing 09-50-3051 and Molex 2478 series crimp terminal.
4. Output connector P2 mates with Molex housing 09-50-3081 and Molex 2478 series crimp terminal.
5. For mating connector kit order part number: SDS150-M CON KIT.
6. For cable harness order part number SDS150-M LOOM.

## Models and Ratings

**SDS180 XP**

Maximum Output Power	Output Voltage	Output Current		Total Regulation <sup>(1)</sup>	Model Number <sup>(2)</sup>
		Minimum	Maximum		
180 W	12 V	0 A	14.58 A	5%	SDS180PS12B
180 W	24 V	0 A	7.50 A	3%	SDS180PS24B
180 W	48 V	0 A	3.75 A	2%	SDS180PS48B

### Notes

1. Total regulation includes line regulation and load regulation.
2. For optional L-bracket version, delete suffix 'B' from model number. Example SDS180PS48.

3. For non-standard voltages contact sales.

## Mechanical Details

### U Channel

Weight: 1.14 lbs (520 g)

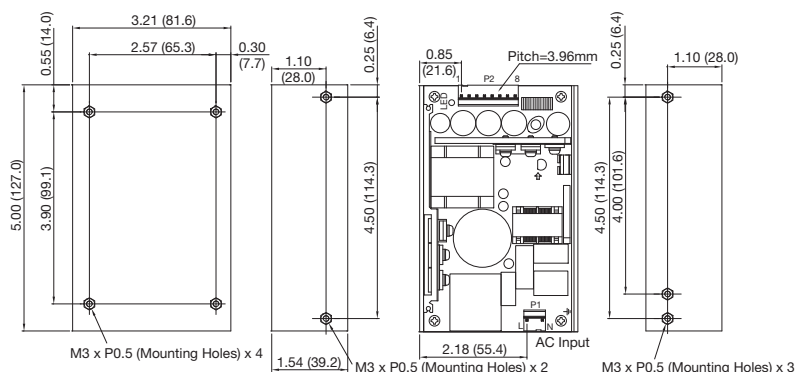

### L-bracket

Weight: 1.06 lbs (480 g)

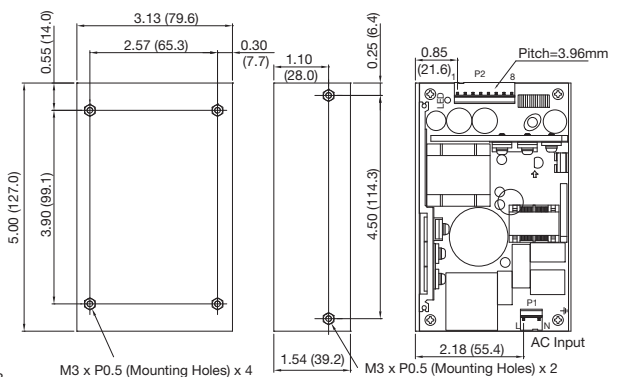

P2 - PIN CONNECTIONS			
Pin	Function	Pin	Function
1	Return	5	V1
2	Return	6	V1
3	Return	7	V1
4	Return	8	V1

### Notes:

1. Dimensions in inches (mm), tolerance  $\pm 0.02$  ( $\pm 0.5$ ).
2. Input connector P1 mates with Molex housing 09-50-3031 and Molex 2478 series crimp terminal.
3. Output connector P2 mates with Molex housing 09-50-3061 (or 09-50-3081) and Molex 2478 series crimp terminal.
4. For mating connector kit order part number: SDS180 CON KIT.
5. For cable harness order part number SDS180 LOOM.
6. Maximum mounting screw penetration: 0.16 (4.0)