

Product Manual

# Vandal-proof latching action switch MSM LA

<b>1</b>	<b>PRODUCT DESCRIPTION.....</b>	<b>2</b>
<b>2</b>	<b>TECHNICAL DATA AND DIMENSIONAL DRAWINGS.....</b>	<b>2</b>
2.1	Technical Data.....	2
2.2	Component Dimensions .....	4
2.3	Hole Dimensions .....	6
2.4	Switching Symbols .....	6
2.5	Contact Layout.....	7
<b>3</b>	<b>ORDER NUMBERS.....</b>	<b>8</b>
3.1	Order numbers MSM LA.....	8
<b>4</b>	<b>PACKAGING .....</b>	<b>9</b>
<b>5</b>	<b>ASSEMBLING .....</b>	<b>10</b>
<b>6</b>	<b>QUALIFICATION TEST.....</b>	<b>10</b>
6.1	IP Protection Class .....	10
6.2	IK Protection Class .....	10
6.3	ESD Protection .....	10
6.4	Salt Spray Test.....	11
<b>7</b>	<b>APPROVALS.....</b>	<b>11</b>
<b>8</b>	<b>ROHS COMPLIANT .....</b>	<b>11</b>

Changes that contribute to technical improvement are subject to alternations							
Seite	Erstelldatum:	Ersteller:	Änderungsdatum:	Geändert von:	Änderungs-Nr.	Datenblatt Nr.	Index
1 of 11	04.08.2007	Mangold	15.11.2007	Schillak	9596	105.9527	a

## 1 PRODUCT DESCRIPTION

Both, the housing and the actuator of the vandal-proof latching action switch MSM LA are made of high-quality stainless steel. By applying this robust and weather-resistant material, the switch is particularly suitable for the use in harsh environments. The MSM LA is available with mounting



diameters of  $\varnothing$  19 and 22 mm.

Different types of contact cover a range of permissible switching voltages from 30 VDC to 250 VAC, switching currents are permissible from 0.1 to 12 Ampere. The MSM is equipped with quick connect terminals to permit fast connection. The cables are plugged onto the switch assembly which is subsequently plugged onto the previously screwed-in housing assembly. Ring-illuminated versions are available for applications at night or as an optical status display. For all types, the MSM LA is available as a double-pole version.

## 2 TECHNICAL DATA AND DIMENSIONAL DRAWINGS

### 2.1 Technical Data

Electrical Data		
Switching Voltage min.	[V <sub>DC</sub> ]	30
Switching Voltage max.	[V <sub>AC</sub> ]	250
Switching Current min.	[A <sub>DC</sub> ]	0.1
Switching Current max.	[A <sub>AC</sub> ]	12
Rated Braking Capacity	[W]	3000
Lifetime (at 8A / 250 VAC)	[Actuations]	50,000
Initial Contact Resistance (at 12V / 1 ADC)	[m $\Omega$ ]	< 100
Insulation Resistance (500 VDC)	[M $\Omega$ ]	> 100

Changes that contribute to technical improvement are subject to alternations

Seite	Erstelldatum:	Ersteller:	Änderungsdatum:	Geändert von:	Änderungs-Nr.	Datenblatt Nr.	Index
2 of 11	04.08.2007	Mangold	15.11.2007	Schillak	9596	105.9527	a

<b>Mechanical Data</b>		
Actuating Force typ.	[N]	10
Actuating Travel typ.	[mm]	4.5
Lifetime mechanical	[Actuations]	150,000
Contact Gap	[mm]	> 3

<b>Starting Torque</b>		MSM 19 LA	MSM 22 LA
Plastic Nut max.	[Nm]	4.5	3.5
Stainless Steel Nut* max.	[Nm]	12	16

\* on request

<b>Climatical Data</b>		
Operating Temperature	[°C]	-40 bis +85
Storage Temperature	[°C]	-40 bis +85
Degree of Protection (DIN EN 60529)	[IP]	IP 67 Frontside IP 00 Rear Side

<b>Ring Illumination</b>		(MSM 19 LA RI and MSM 22 LA RI)
Supply Voltage U <sub>LED</sub>	[V <sub>DC</sub> ]	24

<b>Material</b>	
<b>Component</b>	<b>Material with flammability rating</b>
Switcher Collet	PA66 Blend (UL94-V0 related to d ≥ 1,6mm)
Intermediate Connector	PA66 Blend (UL94-V0 related to d ≥ 1,6mm)
Contact Pin Adapter	PA66 Blend (UL94-V0 related to d ≥ 1,6mm)
<b>Component</b>	<b>Material without flammability rating</b>
Housing	Stainless Steel 1.4305
Actuator	Stainless Steel 1.4305
Illuminated Ring Actuator (Ring Illumination)	PC
Gasket	NBR70

## 2.2 Component Dimensions

### 2.2.1 Component Dimensions M19

#### MSM 19 LA ST

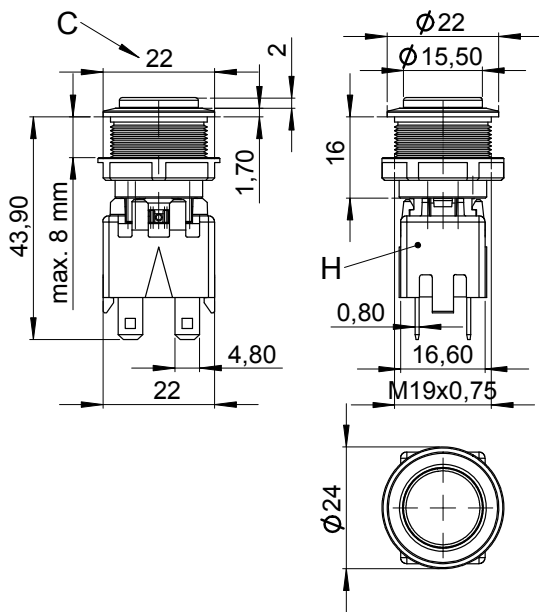

#### MSM 19 LA RI

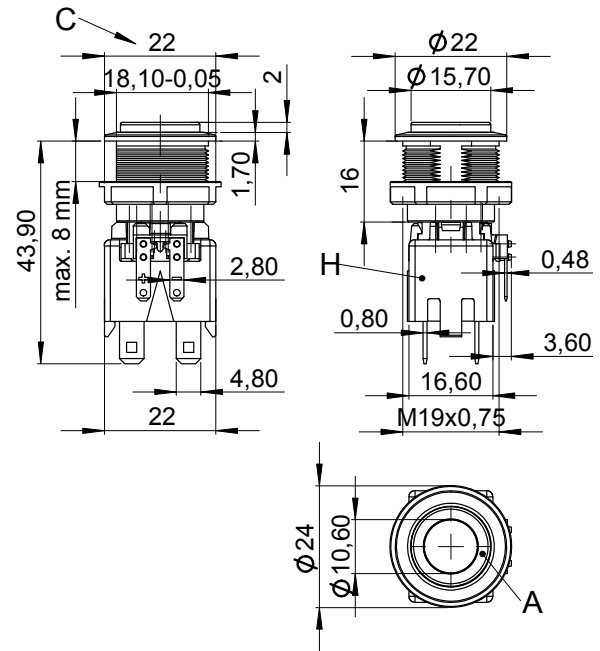

### Legend

- A = Illumination Area
- C = Width Across Flats
- D = Knurled Nut
- H = Switching Element

Changes that contribute to technical improvement are subject to alternations

Seite	Erstelldatum:	Ersteller:	Änderungsdatum:	Geändert von:	Änderungs-Nr.	Datenblatt Nr.	Index
4 of 11	04.08.2007	Mangold	15.11.2007	Schillak	9596	105.9527	a

2.2.2 Component Dimensions M22

MSM 22 LA ST

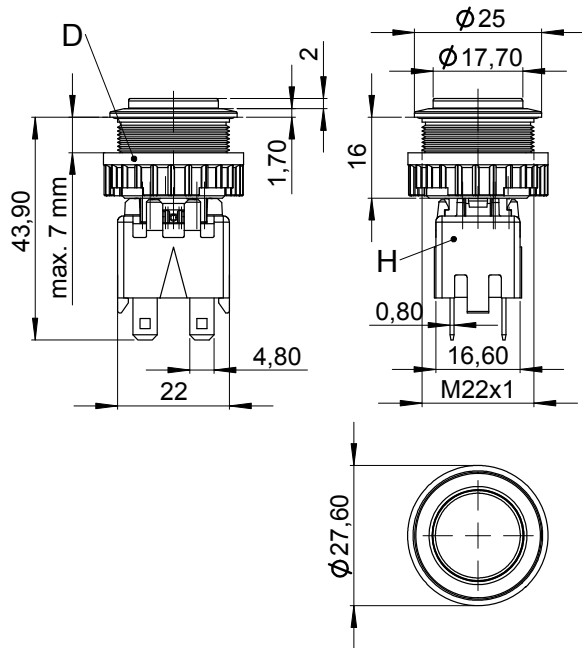

MSM 22 LA RI

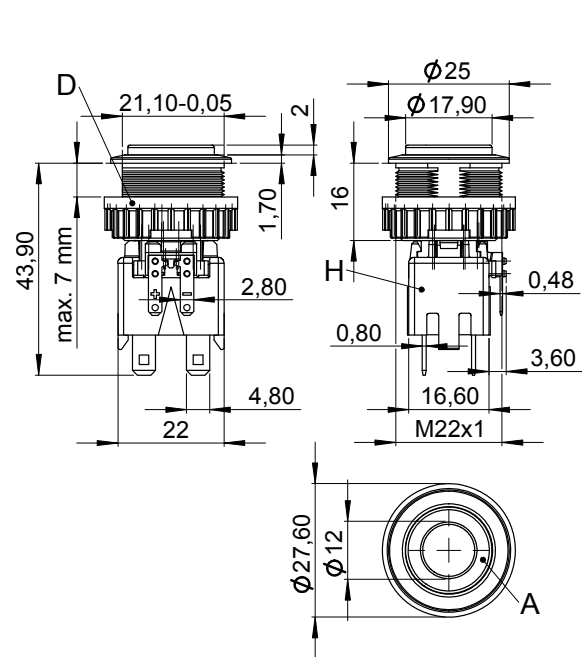

**Legend**

- A = Illumination Area
- C = Width Across Flats
- D = Knurled Nut
- H = Switching Element

Changes that contribute to technical improvement are subject to alternations

Seite	Erstelldatum:	Ersteller:	Änderungsdatum:	Geändert von:	Änderungs-Nr.	Datenblatt Nr.	Index
5 of 11	04.08.2007	Mangold	15.11.2007	Schillak	9596	105.9527	a

### 2.3 Hole Dimensions

**MSM 19 LA ST**

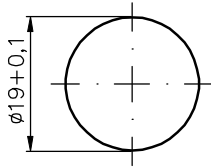

**MSM 19 LA RI**

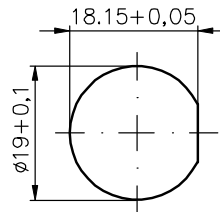

**MSM 22 LA ST**

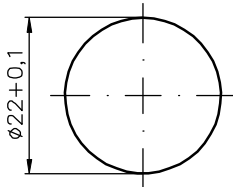

**MSM 22 LA RI**

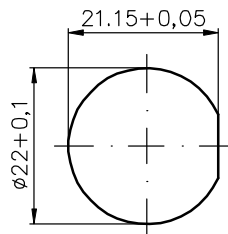

### 2.4 Switching Symbols

**MSM LA ST**

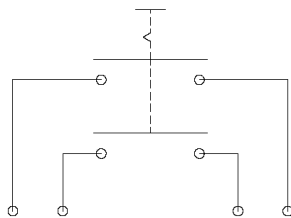

**MSM LA RI**

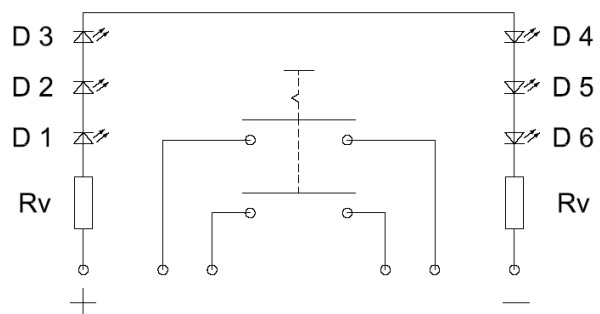

Changes that contribute to technical improvement are subject to alternations							
Seite	Erstelldatum:	Ersteller:	Änderungsdatum:	Geändert von:	Änderungs-Nr.	Datenblatt Nr.	Index
6 of 11	04.08.2007	Mangold	15.11.2007	Schillak	9596	105.9527	a

## 2.5 Contact Layout

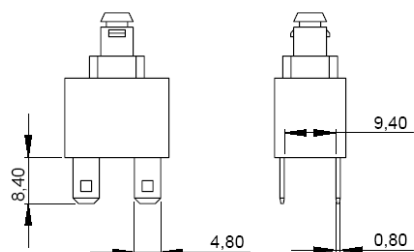
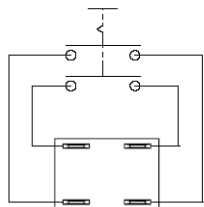

Changes that contribute to technical improvement are subject to alternations							
Seite	Erstelldatum:	Ersteller:	Änderungsdatum:	Geändert von:	Änderungs-Nr.	Datenblatt Nr.	Index
7 of 11	04.08.2007	Mangold	15.11.2007	Schillak	9596	105.9527	a

### 3 ORDER NUMBERS

#### 3.1 Order numbers MSM LA

Mounting Diameter (mm)		Ø 19	Ø 22
------------------------	--	------	------

Latching Action Switch, single-pole			
<i>Standard</i>		1241.6821.1110000	1241.6831.1110000
<i>Ring Illumination red</i>		1241.6824.1111000	1241.6834.1111000
<i>Ring Illumination green</i>		1241.6824.1112000	1241.6834.1112000
<i>Ring Illumination blue</i>		1241.6824.1114000	1241.6834.1114000

Latching Action Switch, double-pole			
Standard		1241.6821.1120000	1241.6831.1120000
Ring Illumination red		1241.6824.1121000	1241.6834.1121000
Ring Illumination green		1241.6824.1122000	1241.6834.1122000
Ring Illumination blue		1241.6824.1124000	1241.6834.1124000

*Italicly written types on request*



## 4 PACKAGING

### MSM LA

MSM 19 LA	10 pieces per box with inlay
MSM 22 LA	10 pieces per box with inlay

The nuts with gaskets and corresponding switch assembly are packed separately and enclosed in the box.

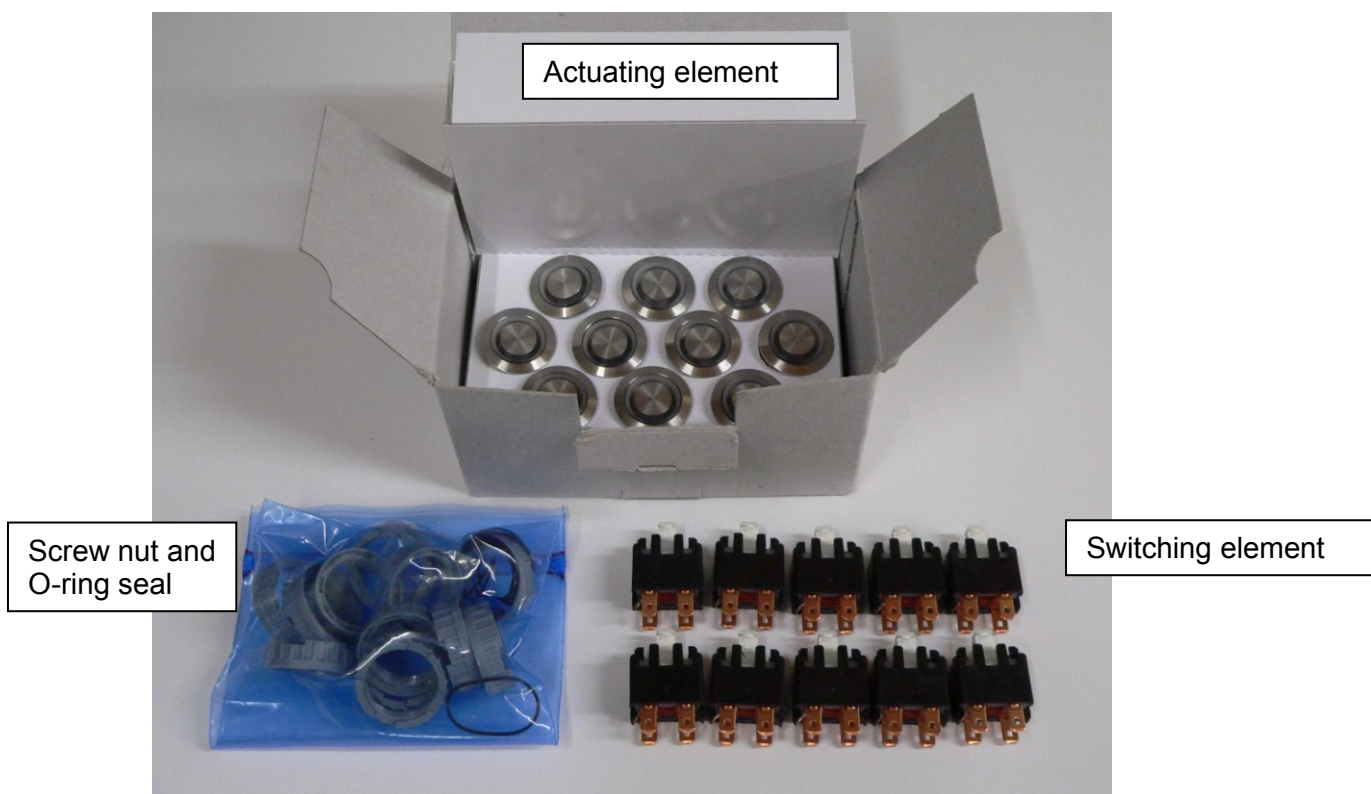

Changes that contribute to technical improvement are subject to alternations

Seite	Erstelldatum:	Ersteller:	Änderungsdatum:	Geändert von:	Änderungs-Nr.	Datenblatt Nr.	Index
9 of 11	04.08.2007	Mangold	15.11.2007	Schillak	9596	105.9527	a

## 5 Assembling

Actuating Element with the sealing ring is mounted to the frontpanel. Afterwards the switching element will be clipped on the actuating element as described by following pictures.

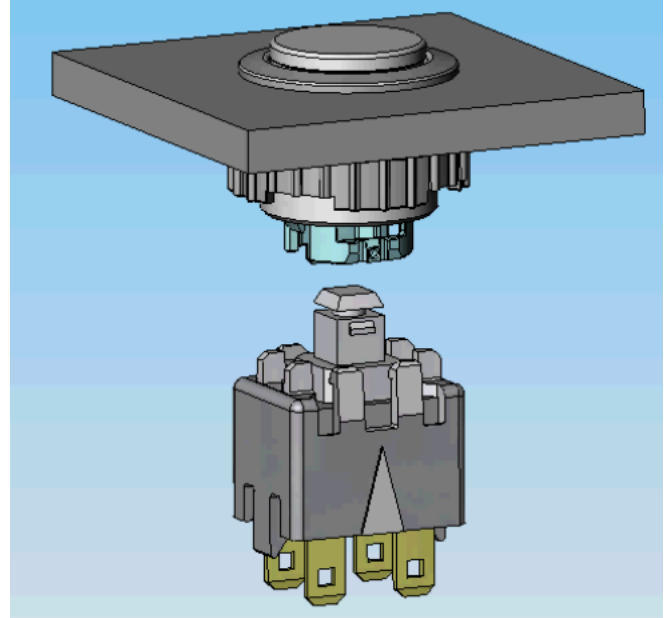
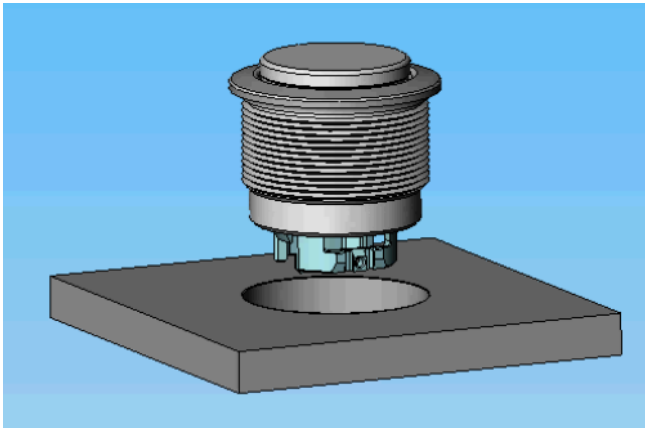

## 6 QUALIFICATION TEST

### 6.1 IP Protection Class

IP Protection Class IEC/DIN/EN/60529	IP 67
--------------------------------------	-------

### 6.2 IK Protection Class

Tested Centrally

IK Protection Class DIN EN 50102	IK07
----------------------------------	------

### 6.3 ESD Protection

ESD-Test according to DIN 61000-4-2:

4kV Contact Discharge	MSM LA ST	Ø 19; 22 mm
-----------------------	-----------	-------------

Changes that contribute to technical improvement are subject to alternations

Seite	Erstelldatum:	Ersteller:	Änderungsdatum:	Geändert von:	Änderungs-Nr.	Datenblatt Nr.	Index
10 of 11	04.08.2007	Mangold	15.11.2007	Schillak	9596	105.9527	a

## 6.4 Salt Spray Test

Salt spray test according to DIN 50021- SS  
24h, 48h and 96h residence time

The surface of the stainless steel material is covered with a molecular-passive layer. Only under very unfavourable conditions it is possible, that iron and rust molecules as well as base metals penetrate the passive layer as foreign substances (pollutions) and initiate the rust process.

The smoothness of the actuator was not affected. After the residence time the tested samples were cleaned under running water and all rust spots could be removed.

## 7 APPROVALS

The listed approvals only refer to the push button switch and not to the complete switch.

**Push button switch:**

Typ	Ausweisnummer	ENEC VDE / KEMA	UL 1054 CSA C22.2 NO55
1682.1101	KEMA 2106068.01	DIN EN 61058	E41791
3292	ENEC 117022-07	DIN EN 61058	E53892

## 8 ROHS COMPLIANT



Changes that contribute to technical improvement are subject to alternations

Seite	Erstelldatum:	Ersteller:	Änderungsdatum:	Geändert von:	Änderungs-Nr.	Datenblatt Nr.	Index
11 of 11	04.08.2007	Mangold	15.11.2007	Schillak	9596	105.9527	a

Print date: 20/11/2007 14:58:00