

## ETD cores and accessories

## ETD44

## CORE SETS

## Effective core parameters

SYMBOL	PARAMETER	VALUE	UNIT
$\Sigma(I/A)$	core factor (C1)	0.589	mm <sup>-1</sup>
$V_e$	effective volume	17800	mm <sup>3</sup>
$l_e$	effective length	103	mm
$A_e$	effective area	173	mm <sup>2</sup>
$A_{min}$	minimum area	172	mm <sup>2</sup>
m	mass of core half	≈47	g

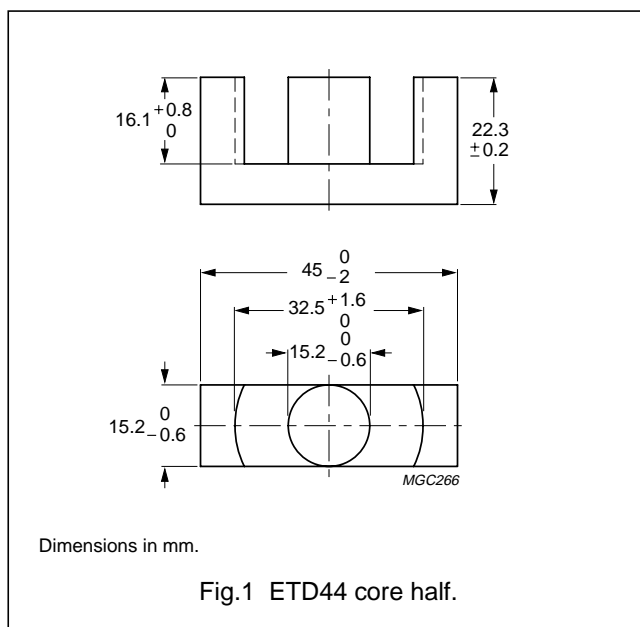

## Core halves

Clamping force  $40 \pm 20$  N. Gapped cores are available on request.

GRADE	$A_L$ (nH)	$\mu_e$	AIR GAP ( $\mu\text{m}$ )	TYPE NUMBER
3C30 <small>des</small>	$3100 \pm 25\%$	≈1550	≈0	ETD44-3C30
3C85	$3800 \pm 25\%$	≈1900	≈0	ETD44-3C85
3C90 <small>des</small>	$3800 \pm 25\%$	≈1900	≈0	ETD44-3C90
3F3 <small>des</small>	$3500 \pm 25\%$	≈1780	≈0	ETD44-3F3

## Properties of core sets under power conditions

GRADE	B (mT) at	CORE LOSS (W) at		
	H = 250 A/m; f = 25 kHz; T = 100 °C	f = 25 kHz; $\hat{B}$ = 200 mT; T = 100 °C	f = 100 kHz; $\hat{B}$ = 100 mT; T = 100 °C	f = 400 kHz; $\hat{B}$ = 50 mT; T = 100 °C
3C30	≥360	≤2.0	≤2.2	–
3C85	≥320	≤2.5	≤3.0	–
3C90	≥330	≤2.0	≤2.2	≤
3F3	≥320	–	≤2.2	≤ 3.9

## ETD cores and accessories

## ETD44

## COIL FORMERS

## General data 18-pins ETD44 coil former

PARAMETER	SPECIFICATION
Coil former material	polybutyleneterephthalate (PBT), glass-reinforced, flame retardant in accordance with "UL 94V-0"; UL file number E45329(R)
Pin material	copper-tin alloy (CuSn), tin-lead alloy (SnPb) plated
Maximum operating temperature	155 °C, "IEC 85" class F
Resistance to soldering heat	"IEC 68-2-20", Part 2, Test Tb, method 1B, 350 °C, 3.5 s
Solderability	"IEC 68-2-20", Part 2, Test Ta, method 1

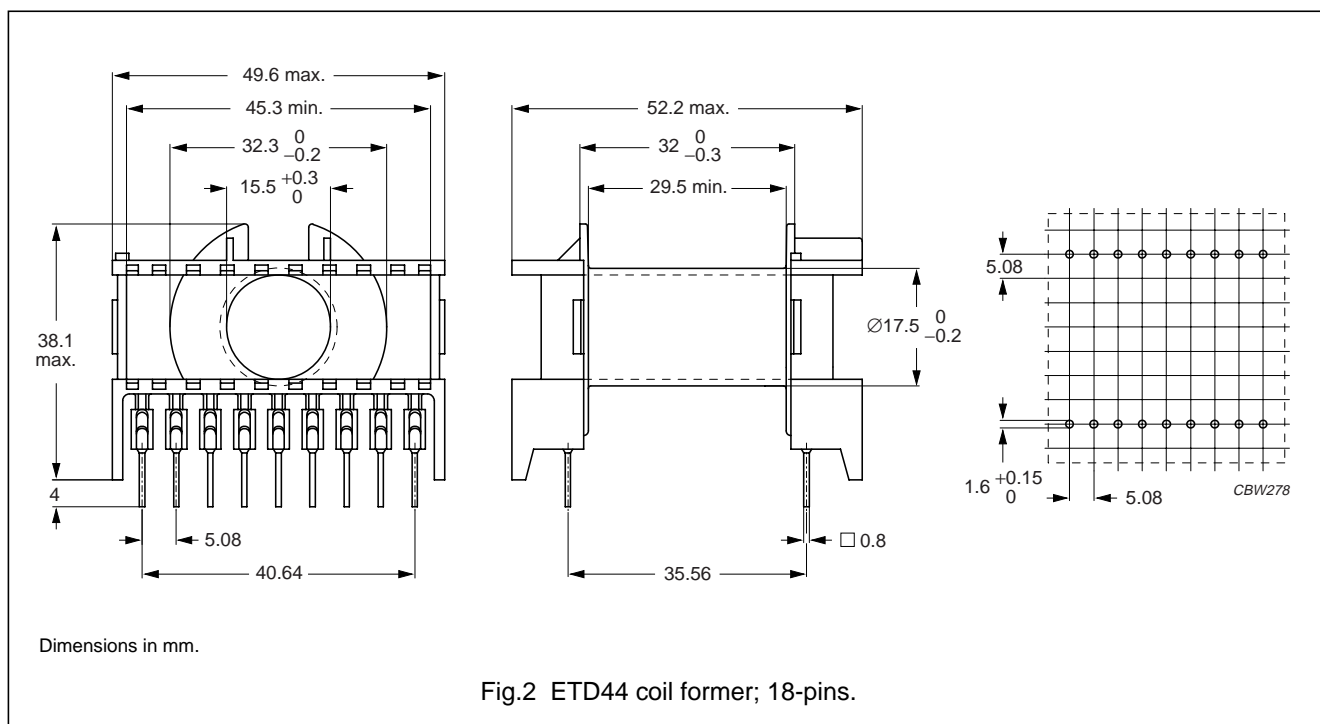

## Winding data for 18-pins ETD44 coil former

NUMBER OF SECTIONS	WINDING AREA (mm <sup>2</sup> )	MINIMUM WINDING WIDTH (mm)	AVERAGE LENGTH OF TURN (mm)	TYPE NUMBER
1	214	29.5	77	CPH-ETD44-1S-18P

## ETD cores and accessories

## ETD44

## MOUNTING PARTS

## General data

ITEM	REMARKS	FIGURE	TYPE NUMBER
Mounting clip	material: stainless steel	3	CLI-ETD44

