

MT9T031



3-Megapixel
1/3-Inch
Image Sensor
48-Pin PLCC or Die

Streamlined Designs for Wide FOV and Electronic Pan/Tilt/Zoom Cameras

1 High Resolution, High Speed, and High Performance

Capture single frames and continuous video at high rates and with crystal-clear detail.

2 Built-in Digital Pan/Tilt/Zoom Functions

This sensor provides a wide FOV that can be subwindowed, positioned, and sized to enable a low-cost, highly reliable pan/tilt/zoom camera.

3 Unparalleled Image Quality

Deliver brilliant, high-resolution color images, rivaling CCD image quality.

4 Mainstream Form Factor

The 1/3-inch optical format fits mainstream surveillance applications and lenses.

5 Ease of Design

With on-chip, 10-bit ADC, this one-chip solution enables a small footprint and easy design.

Applications

- High-resolution security cameras
- Electronic pan/tilt/zoom cameras
- Power-over-Ethernet cameras
- Wide field of view cameras



How to Buy

Production and sample quantities of Aptina products may be ordered through qualified distributors. See our Web site for details. You may also request access to NDA data sheets and other technical documentation by visiting our Web site.

MT9T031

Features

- DigitalClarity® imaging technology
- 3-megapixel resolution (2048H x 1536V)
- 1/3-inch optical format
- 3.2µm x 3.2µm pixel size
- Low-power image sensor
- Global pixel reset
- Row and column pixel binning
- Programmable gain and exposure
- Automatic black level calibration
- Viewfinder and snapshot modes
- On-chip, 10-bit analog-to-digital converter (ADC)

Specifications

Imaging Array

- Optical Format: 1/3-inch
- Active Array: 2048(H) x 1536(V)
- Imaging Area: 6.55mm(H) x 4.92mm(V)
(8.19mm diagonal)

Speed/Output

- Frame Rate: 12 fps (QXGA), 20 fps (UXGA)
27 fps (SXGA), 43 fps (XGA)
93 fps (VGA), with
programmable blanking
- Data Rate: 48 Mp/s
- Master Clock: 48 MHz
- Data Format: 10-bit parallel

Sensitivity

- Pixel Size: 3.2µm x 3.2µm
- Dynamic Range: >61dB
- Responsivity: >1.0 V/lux-sec (550nm)

Power

- Supply: 3.3V nominal (3.0V to 3.6V)
- Consumption: 244mW (nominal)
1.65µW (standby)

Temperature Range

- Operating: 0°C to +60°C

Package: 48-pin PLCC or die

Block Diagram

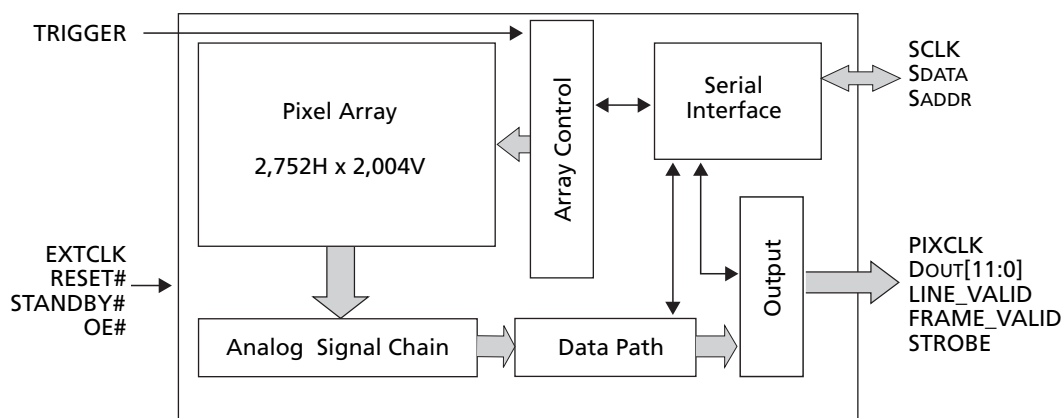

aptina.com

Products are warranted only to meet Aptina's production data sheet specifications. Products and specifications are subject to change without notice. Aptina, the Aptina logo, and DigitalClarity are the property of Micron Technology, Inc. All other trademarks are the property of their respective owners. ©2008 Micron Technology, Inc. All rights reserved. 02/22/08 EN.L

