

AC centrifugal fan

Backward curved



- **Impeller material:** All-plastic impeller of PA 6.6 GV, injected round sheet-metal plate
- **Bearings:** Maintenance-free ball bearings
- **Direction of rotation:** Right, looking at rotor

Nominal data

Type	Motor	Voltage 1 - VAC	Frequency Hz	Air flow m³/h	Speed 1/min	Power consumption W	Current draw A	Sound pressure level dB(A)	Weight kg
R2S133AE1705	M2S052CA	230	50	280	2780	36	0.25	55	0.9

Subject to modification

Characteristic: Pressure over air flow at 50Hz

n [min-1] P₁ [W] ntl [%] Lpa [dBA]

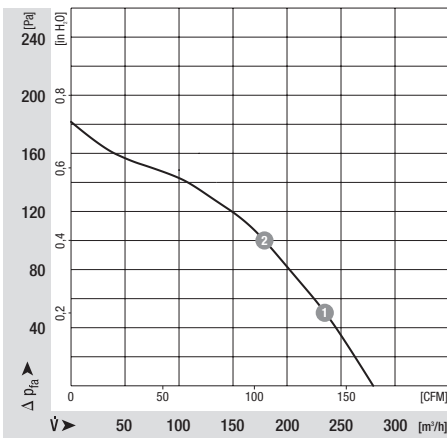

1	2720	38	--	--
2	2720	38	--	--

AC centrifugal fan

Backward curved

Specific drawing

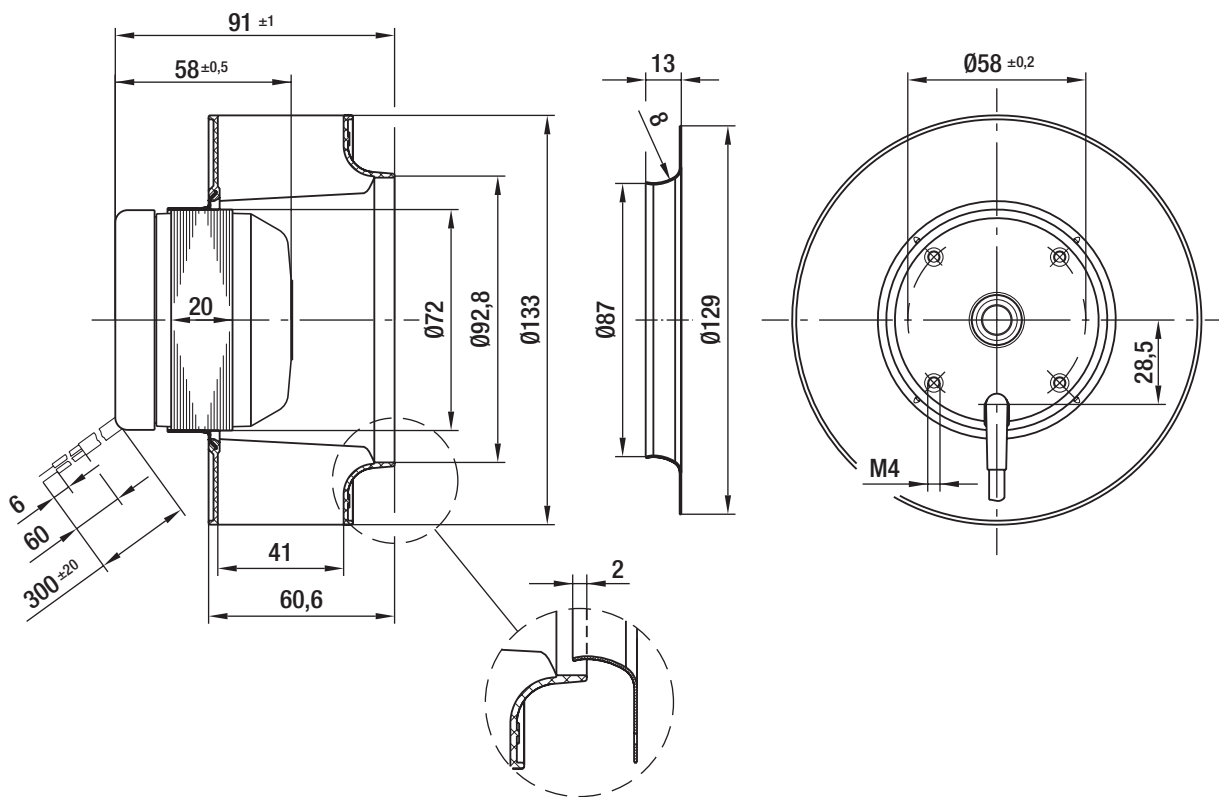

Connection illustration

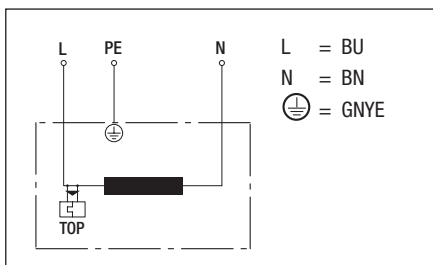

Technical description

- **Impeller material:** All-plastic impeller of PA 6.6 GV, injected round sheet-metal plate
- **Direction of rotation:** Right, looking at rotor
- **Cable layout:** Variable
- **Operating mode:** S1
- **Protection class:** I
- **Approvals:** CE
- **Bearings:** Maintenance-free ball bearings
- **Number of impeller blades:** 7
- **Screw depth:** Max. 5 mm
- **Insulation class:** "B"
- **System of protection:** IP 22

AC centrifugal fan

Backward curved

Contact

ebm-papst Mulfingen GmbH & Co. KG

Bachmühle 2

D-74673 Mulfingen

Phone +49 (0) 79 38 / 81-0

Fax +49 (0) 79 38 / 81-110

info1@de.ebmpapst.com

www.ebmpapst.com