

ZK 1-2/11.90

WAGO[®]

A reliable contact - everytime!

464-740
To 465-033

238-855

**Miniature Rail-Mounted Terminal Blocks,
Modular Terminal Blocks and Terminal Block Strips with
Cage-Clamp Spring* for Solid, Stranded and Flexible Conductors**

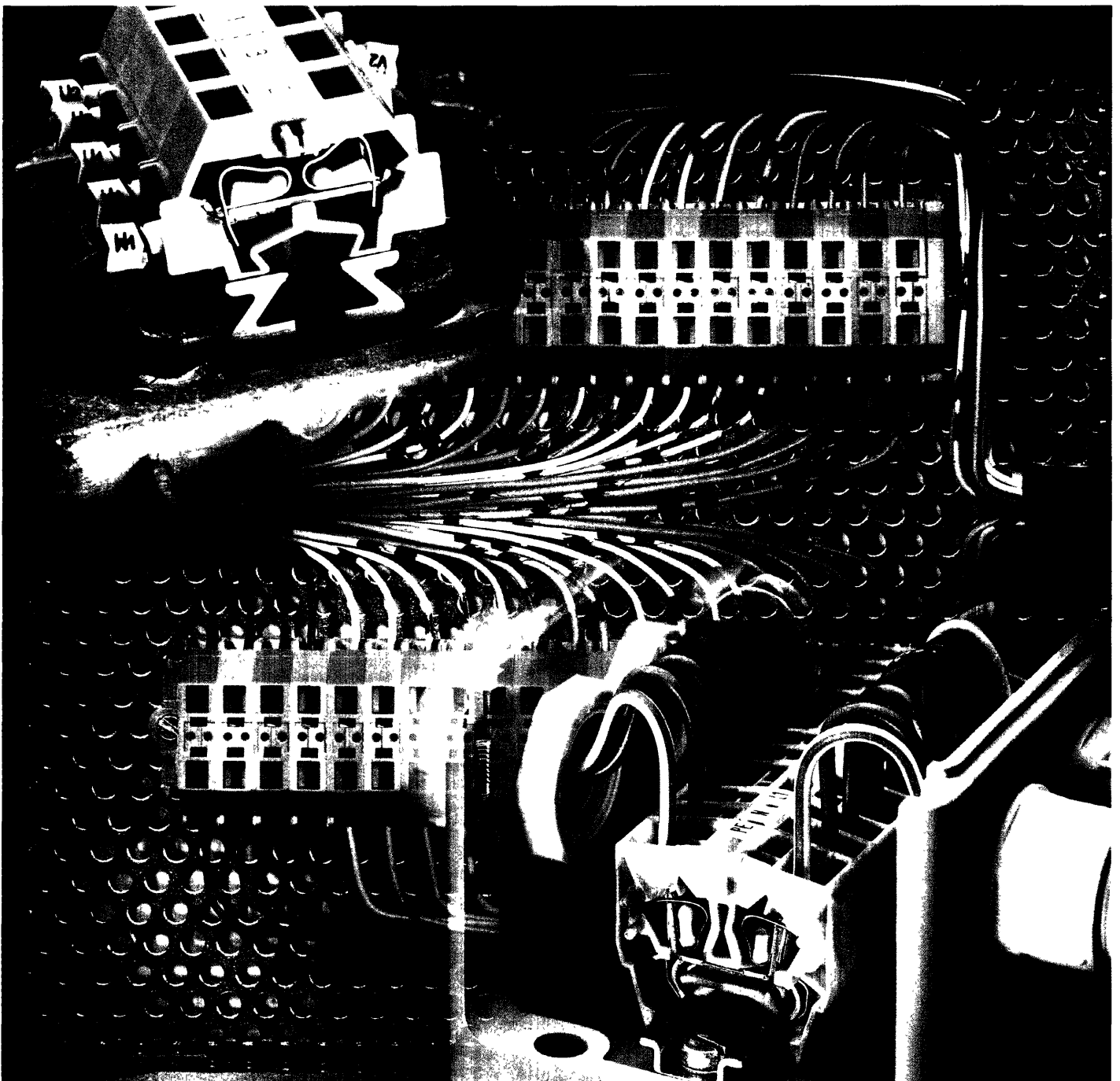

* a technical innovation from WAGO

Miniature rail-mounted terminal blocks for rails TS 15

WAGO	Description and handling; _____	3
Front-entry	miniature rail-mounted terminal blocks; series 264	
	EEx e II-miniature through terminal blocks; series 264 _____	6
	EEx i-miniature through terminal blocks; series 264 _____	4
	Miniature ground (earth) conductor terminal blocks; series 264 _____	5
	Miniature through terminal blocks; series 264 _____	4
	Mini-WSB-Quick marking system _____	7
	Order example, order form "Completely mounted rails" _____	8 – 9

Modular terminal blocks and terminal block strips*

WAGO	Description and handling; _____	11
Front-entry	series 264	
	EEx e II-modular terminal blocks _____	15
	with fixing flange; series 264	
	EEx e II-modular terminal blocks _____	16
	with snap-in mounting foot; series 264	
	EEx e II-terminal block strips _____	17
	with fixing flanges or snap-in mounting feet; series 264	
	Example of an assembly, order form _____	30 – 31
	"Custom-assembled terminal block strips"	
	Modular terminal blocks _____	12
	with fixing flange; series 264	
	Modular terminal blocks _____	13
	with snap-in mounting foot; series 264	
	Terminal block strips _____	14
	with fixing flanges or snap-in mounting feet; series 264	
WAGO	Description and handling; _____	19
Side-entry	series 260 to 262	
	EEx e II-modular terminal blocks _____	26
	with fixing flange or mounting foot; series 262	
	EEx e II-terminal block strips _____	27
	with fixing flanges or mounting feet; series 262	
	Example of an assembly, order form _____	30 – 31
	"Custom-assembled terminal block strips"	
	Marking accessories _____	28 – 29
	Modular terminal blocks _____	20
	with fixing flange or snap-in mounting foot; series 260	
	Modular terminal blocks _____	22
	with fixing flange or snap-in mounting foot; series 261	
	Modular terminal blocks _____	24
	with fixing flange or snap-in mounting foot; series 262	
	Terminal block strips _____	21
	with fixing flanges or mounting feet; series 260	
	Terminal block strips _____	23
	with fixing flanges or mounting feet; series 261	
	Terminal block strips _____	25
	with fixing flanges or mounting feet; series 262	

Description and handling

Miniature rail-mounted terminal blocks with cage-clamp spring

Series 264

WAGO Front-entry

Marking with miniature-WSB-quick marking system

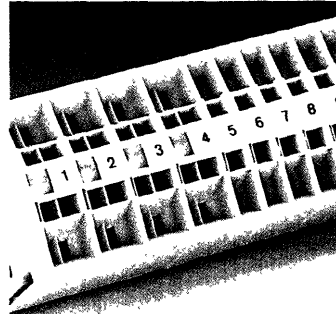

Suitable for all carrier rails TS 15

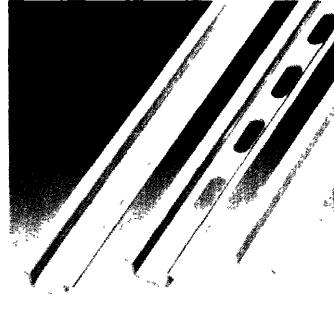

Formation of groups by use of intermediate plates

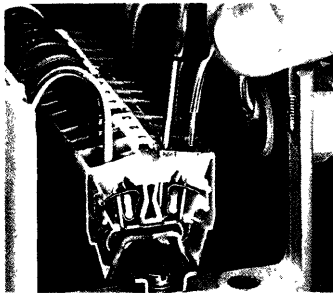
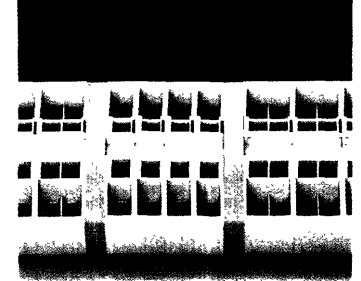

Connection of conductors

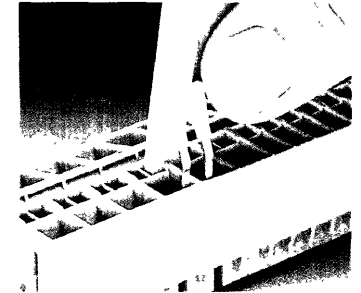
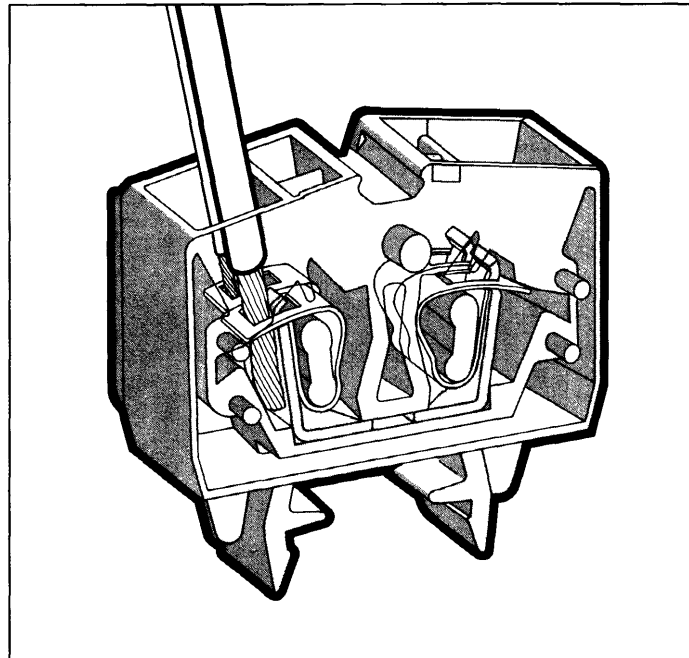

Commoning with comb-type jumper bar

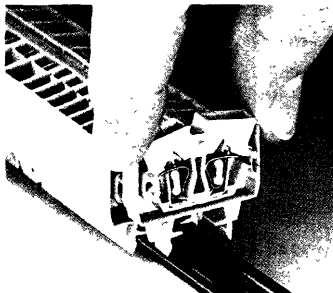

Assembly on the carrier rail TS 15

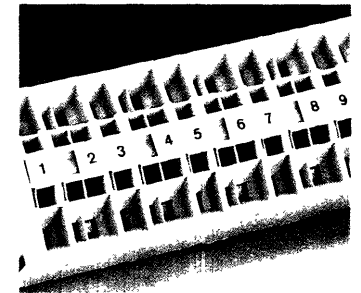

Mixing of 2- and 4-conductor term. blocks

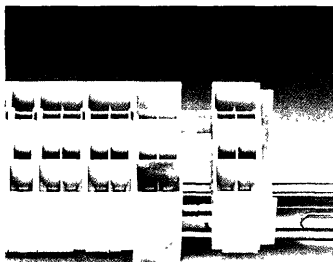

Quick assembly buttons prevent reverse mounting

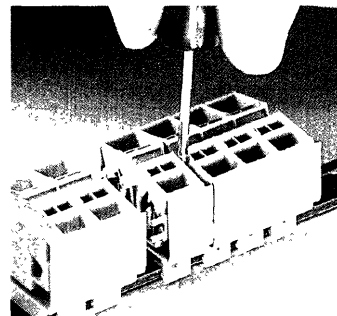

Removal: Separate terminal block strip and shift individual terminal block laterally ...

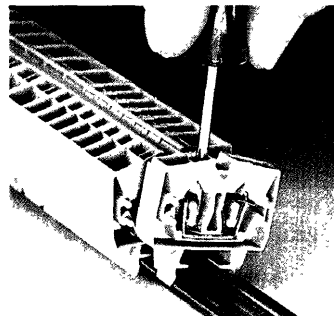

... and remove from the carrier rail

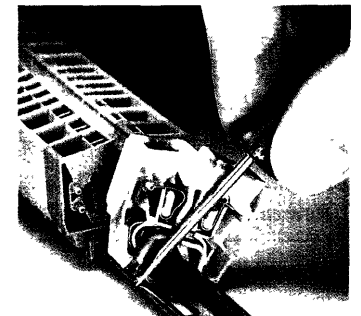

Removal of a ground (earth) conductor terminal block from the carrier rail

The cage-clamp spring clamps the following copper conductors:

For aluminium conductors please refer to the remarks on page 32!



solid



stranded*



flexible*



flexible with ferrule (gastight crimped) ①

















flexible with pin terminal (gastight crimped)

① When using ferrules, the maximum conductor cross-section which can be accommodated is one size below the nominal cross-section rating of the terminal block. (Except for EEx e II terminal blocks, where this has been allowed for!)

* If used in a corrosive atmosphere, please refer to the information concerning "Connection of flexible conductors" on page 32.

Miniature through terminal blocks

WAGO Front-entry

<p>AWG 26 – 14 0.08 mm² – 2.5 mm² 600 V, 15 A  750 V~, Gr. C 600 V, 20 A  26 A Terminal block width 0.236 in (6 mm) Stripped length 0.35 in (8 – 9 mm)</p> <p><small>*      </small></p>	<p>2 x AWG 26 – 14 2 x 0.08 – 2.5 mm² 600 V, 15 A  750 V~, Gr. C 600 V, 20 A  26 A Terminal block width 0.393 in (10 mm) Stripped length 0.35 in (8 – 9 mm)</p> <p><small>*     </small></p>
--	--

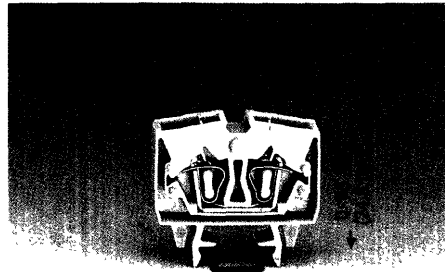

← 1.26 (32 mm) →

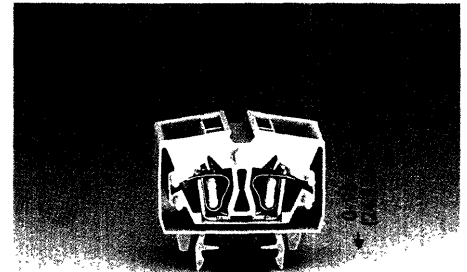

← 1.26 (32 mm) →









① For details concerning markings with the corresponding item-nos. please see page 7

② from upper edge of carrier rail

Suitable for EEx i-applications

Description		Item-No.	Pack.-unit pcs.	Item-No.	Pack.-unit pcs.
Through terminal block, for rail TS 15	grey	264-701	100	264-721	100
	blue	264-704	100	264-724 	100
	orange	264-706	100	264-726	100
		2-conductor through terminal blocks		4-conductor through terminal blocks	

Accessories

	End- and intermediate plate	grey orange	0.157 in (4 mm) thick	264-368	25	0.157 in (4 mm) thick	264-368	25
				264-369	25		264-369	25
	Comb-type jumper bar, insulated, 2-pole	grey	$I_N = 15 A$	264-402	200 (8 x 25)	reduction of cross section to AWG 16 (1.5 mm ²)	264-402	200 (8 x 25)
						reduction of cross section to AWG 16 (1.5 mm ²)		
	Operating tool, insulated	2-pole		280-432	1		280-432	1
	Plastic end stop, 0.236 in (6 mm) wide for rail TS 15			249-101	25		249-101	25
	Miniature-WSB-quick marker card, 10 strips with 10 markers each, white with black printing			248-5.. ①	5 cards		248-5.. ①	5 cards
	Carrier rail TS 15, 0.59 x 0.216 in (15 x 5.5 mm), 0.039 in (1 mm) th., steel, zinc plated a. yellow chrom.		6'6" (2 m) long perforated	210-111	1	acc. to DIN EN 50045	210-111	1
	Carrier rail TS 15, 0.59 x 0.216 in (15 x 5.5 mm), 0.039 in (1 mm) th., steel, zinc plated a. yellow chrom.		6'6" (2 m) long unperforated	210-295	1	acc. to DIN EN 50045	210-295	1
	Carrier rail TS 15, 0.59 x 0.216 in (15 x 5.5 mm), 0.039 in (1 mm) th., aluminium		6'6" (2 m) long unperforated	210-296	1	acc. to DIN EN 50045	210-296	1

Remarks concerning application



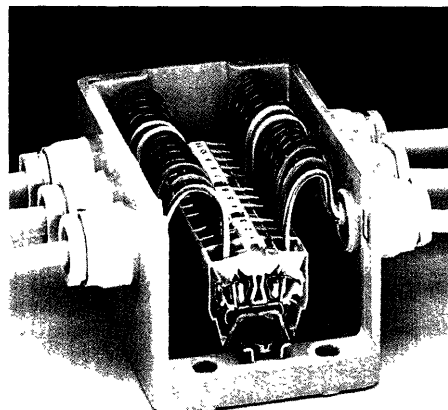

By arranging the cable seals above the wiring level of the WAGO front-entry miniature rail-mounted terminal blocks, extremely small enclosures can be used offering free and optimum handling and cable introduction.



* For approvals with the corresponding nominal data please see pages 34 – 35.

Miniature ground (earth) conductor terminal blocks

WAGO Front-entry

	<p>2 x AWG 26 – 14  2 x 0.08 – 2.5 mm² 2 x AWG 26 – 14 </p> <p>Terminal block width 0.393 in (10 mm) Stripped length 0.35 in (8 – 9 mm)</p> <p>*   </p>	
--	---	--

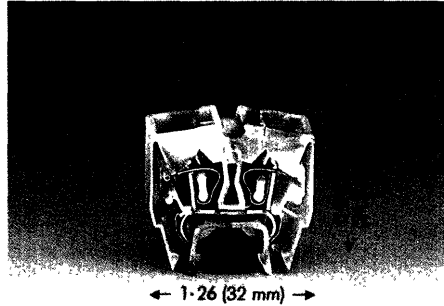









① For details concerning markings with the corresponding item-nos. please see page 7

② from upper edge of carrier rail

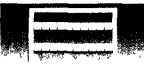
Description	Item-No.	Pack.-unit pcs.	
Ground (earth) conductor terminal block, for rail TS 15 green-yellow	264-727	100	
	4-conductor ground (earth) conductor terminal block		

Accessories

	End- and intermediate plate grey orange	0.157 in (4 mm) thick	
		264-368	25
		264-369	25
	Comb-type jumper bar, insulated, 2-pole grey I _N = 15 A		
		264-402	25
		reduction of cross section to AWG 16 (1.5 mm ²)	
	Operating tool, insulated 2-pole		
		280-432	1
	Plastic end stop, 0.236 in (6 mm) wide for rail TS 15		
		249-101	25
	Miniature-WSB-quick marker card, 10 strips with 10 markers each, white with black printing		
		248-5.. ①	5 cards
	Carrier rail TS 15, 0.59 x 0.216 in (15 x 5.5 mm), 0.039 in (1 mm) th., steel, zinc plated a. yellow chrom.	6'6" (2 m) long perforated acc. to DIN EN 50045	
		210-111	1
	Carrier rail TS 15, 0.59 x 0.216 in (15 x 5.5 mm), 0.039 in (1 mm) th., steel, zinc plated a. yellow chrom.	6'6" (2 m) long unperforated acc. to DIN EN 50045	
		210-295	1
	Carrier rail TS 15, 0.59 x 0.216 in (15 x 5.5 mm), 0.039 in (1 mm) th., aluminium	6'6" (2 m) long unperforated acc. to DIN EN 50045	
		210-296	1

Remarks concerning application



Assembly on the carrier rail

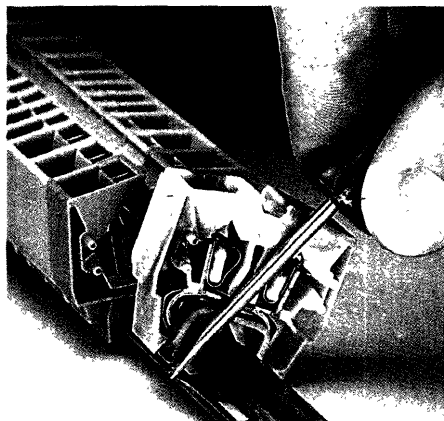

Removal from the carrier rail

EEx e II-Miniature through terminal blocks

WAGO Front-entry



AWG 16 (1.5 mm²) ①
250 V~
16 A
Terminal block width 0.236 in (6 mm)
Stripped length 0.35 in (8 – 9 mm)
PTB-certificate: Ex-90.C.3101 U



AWG 16 (1.5 mm²) ①
250 V~
16 A
Terminal block width 0.393 in (10 mm)
Stripped length 0.35 in (8 – 9 mm)
PTB-certificate: Ex-90.C.3101 U



① The cross-sections refer to conductors without and with gastight crimped ferrules.
 For types of conductors and their preparation see page 33 extract form "Electrical equipment for hazardous environments".

② from upper edge of carrier rail

③ For details concerning markings with the corresponding item-nos. please see page 7

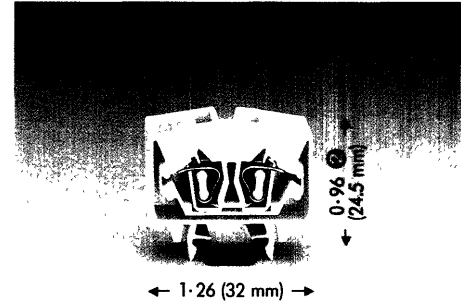
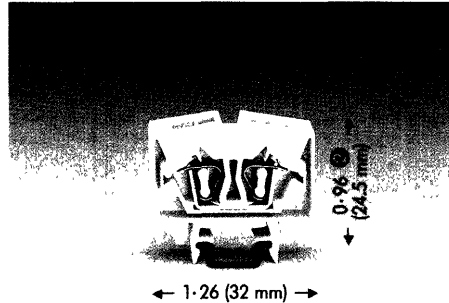

Description	Item-No.	Pack.-unit pcs.	Item-No.	Pack.-unit pcs.
Through terminal block, light grey for rail TS 15	264-120	100	264-220	100
	2-conductor through terminal blocks		4-conductor through terminal blocks	

Accessories

	End- and intermediate plate grey	0.157 in (4 mm) thick	264-368	25	0.157 in (4 mm) thick	264-368	25
	Comb-type jumper bar, insulated, 2-pole $I_N = 15 A$ grey	reduction of cross section to AWG 16 (1.5 mm ²)	264-402	25	reduction of cross section to AWG 16 (1.5 mm ²)	264-402	25
	Operating tool, insulated 2-pole		280-432	1		280-432	1
	Plastic end stop, 0.236 in (6 mm) wide for rail TS 15		249-101	25		249-101	25
	Miniature-WSB-quick marker card, 10 strips with 10 markers each, white with black printing		248-5.. ③	5 cards		248-5.. ③	5 cards
	Carrier rail TS 15, 0.59 x 0.216 in (15 x 5.5 mm), 0.039 in (1 mm) th., steel, zinc plated a. yellow chrom.	6'6" (2 m) long perforated acc. to DIN EN 50045	210-111	1	6'6" (2 m) long perforated acc. to DIN EN 50045	210-111	1
	Carrier rail TS 15, 0.59 x 0.216 in (15 x 5.5 mm), 0.039 in (1 mm) th., steel, zinc plated a. yellow chrom.	6'6" (2 m) long unperforated acc. to DIN EN 50045	210-295	1	6'6" (2 m) long unperforated acc. to DIN EN 50045	210-295	1
	Carrier rail TS 15, 0.59 x 0.216 in (15 x 5.5 mm), 0.039 in (1 mm) th., aluminium	6'6" (2 m) long unperforated acc. to DIN EN 50045	210-296	1	6'6" (2 m) long unperforated acc. to DIN EN 50045	210-296	1

Miniature WSB-quick marking system, for series 264

Horizontal marking Consecutive letters/symbols per strip for 2-conductor terminal blocks Series 264	Horizontal marking Consecutive letters/symbols per strip for 4-conductor terminal blocks Series 264	Coloured marker cards Horizontal marking Additional item-numbers for 2- and 4-conductor terminal blocks Series 264
--	--	---

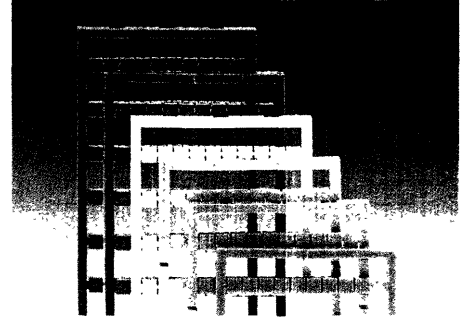
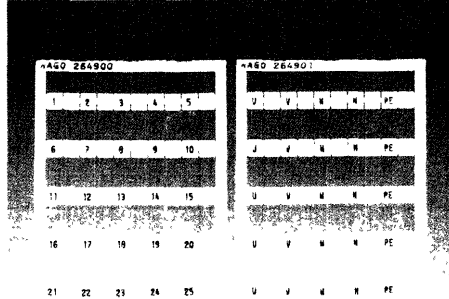
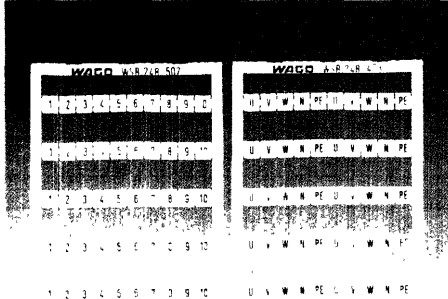

Marking per card	Item-No.	Pack.-unit pcs.	Marking per card	Item-No.	Pack.-unit Verp.-Einh.	Colour	Item-No.	Pack.-unit pcs.
1 ... 10 (10x)	248-502	5 cards	1, , 2, , 3, , 4, , 5, ;			Coloured marker cards		
11 ... 20 (10x)	248-503	5 cards	to				All markings stated opposite are also available with black printing on coloured marker cards.	
21 ... 30 (10x)	248-504	5 cards	46, , 47, , 48, , 49, , 50, ; (1 each)					
31 ... 40 (10x)	248-505	5 cards	264-900		5 cards			
41 ... 50 (10x)	248-506	5 cards	U, , V, , W, , N, , PE, ; (10x)				Add. item-no. for coloured marker cards	
51 ... 60 (10x)	248-569	5 cards	264-901		5 cards		yellow	.../000-002
61 ... 70 (10x)	248-570	5 cards	L1, , L2, , L3, , N, , PE, ; (10x)				red	.../000-005
71 ... 80 (10x)	248-571	5 cards	264-902		5 cards		blue	.../000-006
81 ... 90 (10x)	248-572	5 cards	1, , 1, , 1, , 1, , 1, ; (10x)				grey	.../000-007
91 ... 100 (10x)	248-573	5 cards	264-903		5 cards		orange	.../000-012
1 ... 50 (2x)	248-566	5 cards	2, , 2, , 2, , 2, , 2, ; (10x)			light green	.../000-017	
U, V, W, N, PE, U, V, W, N, PE; (5x)			264-904		5 cards			
L1, L2, L3, N, PE, L1, L2, L3, N, PE; (5x)	248-473	5 cards	3, , 3, , 3, , 3, , 3, ; (10x)					
plain,	248-501	5 cards	264-905		5 cards			
for self-marking								
Marking pen,	210-110	1						
with fibre tip,								
for permanent inscription								
All printings for WSB-cards in master catalogue HK 1-4, pages 3.4 - 3.7, item-no. 209-5... are also available as miniature WSB-cards. In that case the basic item-no changes to 248-5... The last two figures are identical for both versions. Example Marking WSB-card Mini-WSB-card 51 ... 100 209-507 248-507								
							Remark:	
							Please note that coloured marker cards are of a higher price and longer delivery than normal cards.	

Order Form "Custom-assembled miniature rail-mounted term. blocks, series 264"

Customer's name: _____

Modification: 5, 4, 3, 2, 1

Page 1 of _____

Release note: _____

Drawing-No.: _____

WAGO-Item-No.: _____

Original Item-No. Date Name

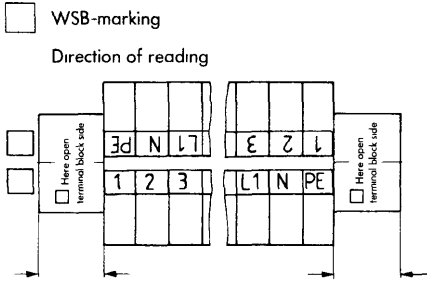

Carrier rail TS 15

- Standard rail with slotted holes
4.2 x 12.2 (210-111)
- Length = _____ mm
- Special rail (please state dimension)
- steel, galvanized and yellow chromated, except for cut edges
 - steel, galvanized allover and yellow chromated
 - aluminium

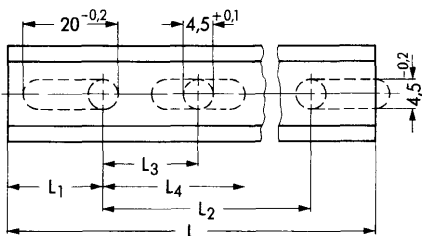

Dimensions:

- L = _____ mm ± 0.4 (min. 30/ max. 1999)
- L₁ = _____ mm ± 0.2 (min. 4)
- L₂ = _____ mm ± 0.2
- L₃ = _____ mm ± 0.2
- L₄ = _____ mm ± 0.2

For longer rails please state further fixing positions L₅, L₆ etc. if necessary.

Types of fixing:

- round hole $\varnothing 4.5 (+0.1)$
- slotted hole closed
4.5 x 20 (-0.2)
- slotted hole open
- threaded bolt M 4 x 6,
only possible on steel
rail, same position
as round hole

State of modification	Sequence	Item-No.	Jumper	Term. block marking	Jumper	State of modification	Sequence	Item-No.	Jumper	Term. block marking	Jumper
<input type="checkbox"/> Here open side of terminal block											
	1						49				
	2						50				
	3						51				
	4						52				
	5						53				
	6						54				
	7						55				
	8						56				
	9						57				
	10						58				
	11						59				
	12						60				
	13						61				
	14						62				
	15						63				
	16						64				
	17						65				
	18						66				
	19						67				
	20						68				
	21						69				
	22						70				
	23						71				
	24						72				
	25						73				
	26						74				
	27						75				
	28						76				
	29						77				
	30						78				
	31						79				
	32						80				
	33						81				
	34						82				
	35						83				
	36						84				
	37						85				
	38						86				
	39						87				
	40						88				
	41						89				
	42						90				
	43						91				
	44						92				
	45						93				
	46						94				
	47										
	48										
											<input type="checkbox"/> Here open side of terminal block

Order Form "Custom-assembled miniature rail-mounted term. blocks, series 264"

Release note:

Customer's name:
Musterbau KG

Modification	5			
	4			
	3			
	2			
	1			

Drawing-No.:

WAGO-Item-No.:

Original	Item-No.	Date	Name

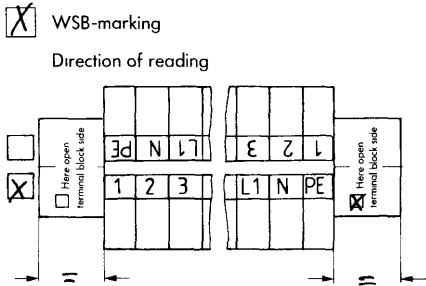

Carrier rail TS 15

Standard rail with slotted holes
4.2 x 12.2 (210-111)
Length = _____ mm

- Special rail (please state dimension)
- steel, galvanized and yellow chromated, except for cut edges
 - steel, galvanized allover and yellow chromated
 - aluminium

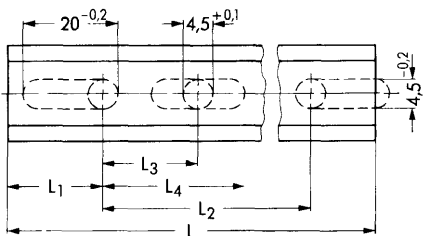

Dimensions:
 L = 80 mm ± 0.4 (min. 30/max. 1999)
 L₁ = 20 mm ± 0.2 (min. 4)
 L₂ = 40 mm ± 0.2
 L₃ = _____ mm ± 0.2
 L₄ = _____ mm ± 0.2

For longer rails please state further fixing positions L₅, L₆ etc. if necessary.

Types of fixing:

- round hole ∅ 4.5 (+0.1)
- slotted hole closed 4.5 x 20 (-0.2)
- slotted hole open
- threaded bolt M 4 x 6, only possible on steel rail, same position as round hole

State of modification Sequence	Item-No.	Jumper <input type="checkbox"/>	Term. block marking	Jumper <input type="checkbox"/>	State of modification Sequence	Item-No.	Jumper	Term. block marking	Jumper
1	249-101				49				
2	264-727		5/-		50				
3	264-724		4/-		51				
4	264-704		3		52				
5	264-721	<input type="checkbox"/>	2/-		53				
6	264-701	<input type="checkbox"/>	1		54				
7	264-368				55				
8	249-101				56				
9					57				
10					58				
11					59				
12					60				
13					61				
14					62				
15					63				
16					64				
17					65				
18					66				
19					67				
20					68				
21					69				
22					70				
23					71				
24					72				
25					73				
26					74				
27					75				
28					76				
29					77				
30					78				
31					79				
32					80				
33					81				
34					82				
35					83				
36					84				
37					85				
38					86				
39					87				
40					88				
41					89				
42					90				
43					91				
44					92				
45					93				
46					94				
47									
48									

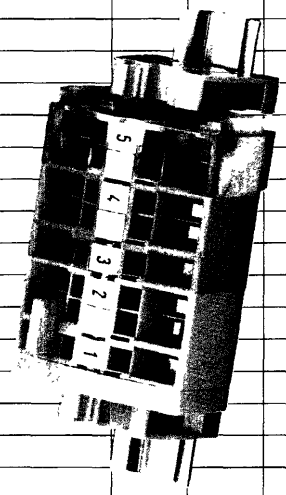

Here open side of terminal block

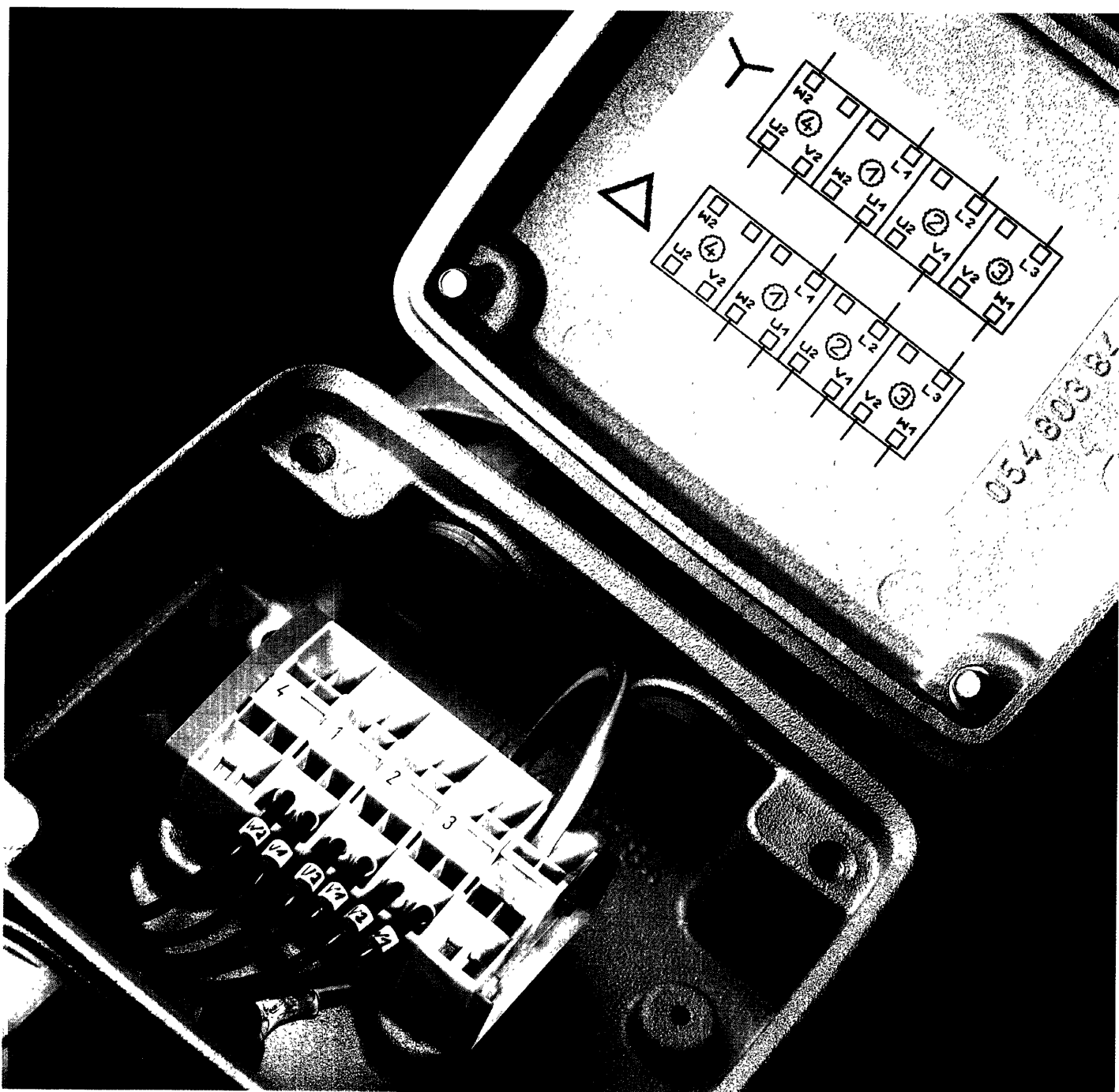

Description and handling

Modular terminal blocks and terminal block strips with cage-clamp spring

Series 264

WAGO Front-entry

Marking with WSB-quick marking system

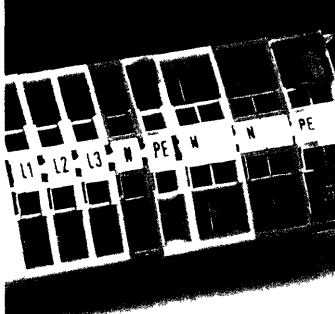

Terminal block strips with fixing flanges, screw-fixing

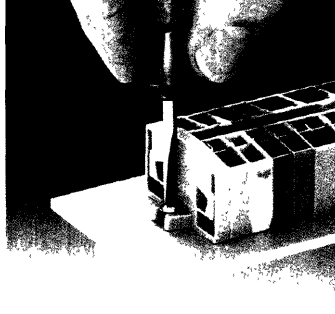

Terminal block strips with snap-in mounting feet, hole-fixing

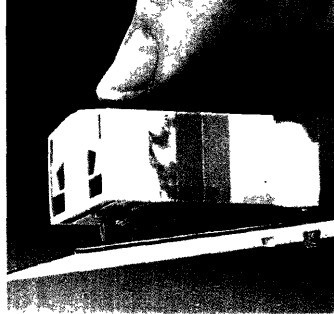

Terminal block strips with snap-in mounting feet on special aluminium carrier rail

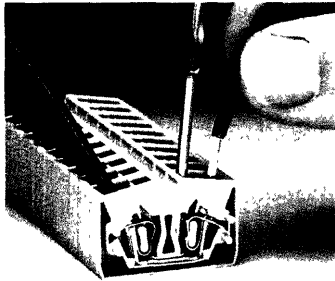
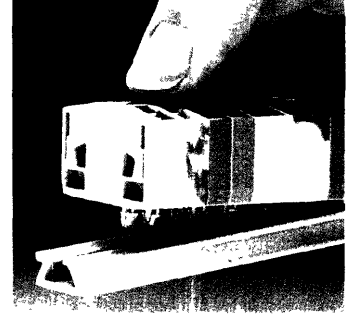

Connection of conductors

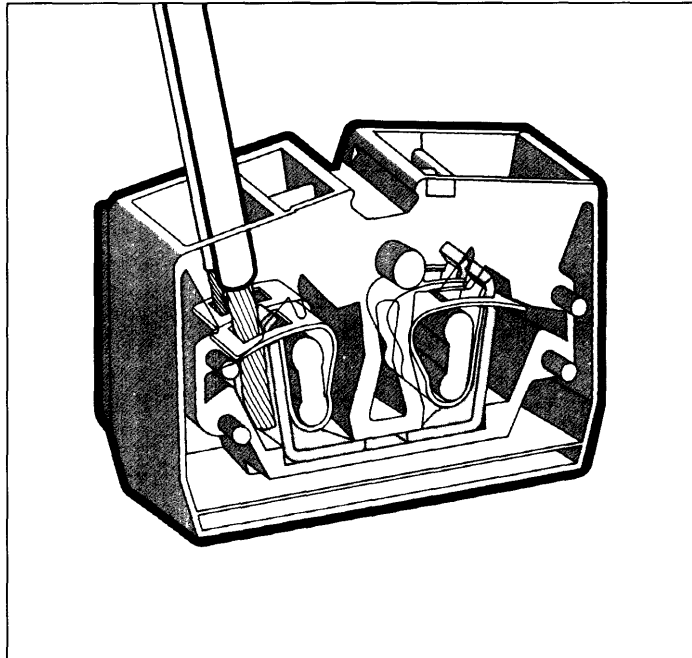

Terminal block strips with snap-in mounting feet, assembly of mount. adap. 209-120*

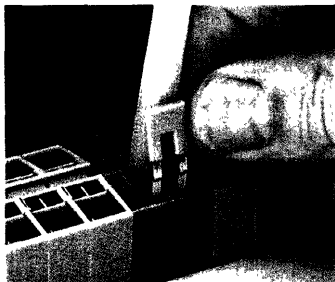

Commoning with jumper bars

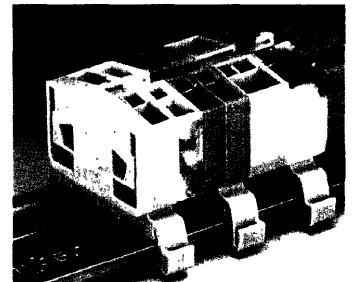

Terminal block strips with snap-in mounting feet on carrier rail TS 35

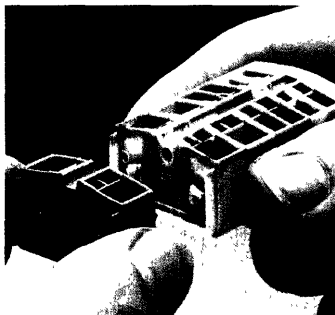

Assembly of modular terminal blocks to terminal block strips

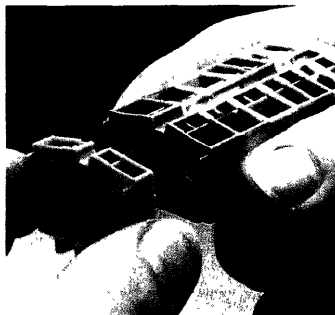

Mounting of an "end terminal block" with fixing flange

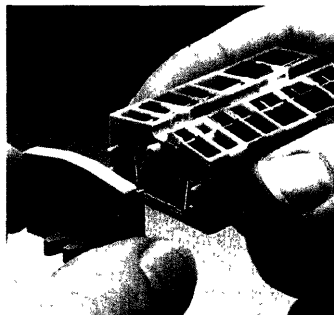

Mounting of an end plate

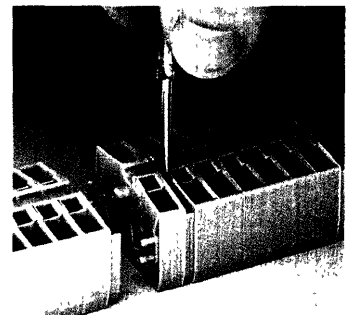

Removal of a terminal block strip from the rail

* The distance between mounting adapters should be 1.38 - 1.57 in (35 - 40 mm) max.

The cage-clamp spring clamps the following copper conductors:

For aluminum conductors please refer to the remarks on page 32!



solid



stranded**



flexible**



flexible with ferrule (gastight crimped) ①



flexible with pin terminal (gastight crimped)

① When using ferrules, the maximum conductor cross-section which can be accommodated is one size below the nominal cross-section rating of the terminal block. (Except for EEx e II-terminal blocks, where this has been allowed for!)

** If used in a corrosive atmosphere, please refer to the information concerning "Connection of flexible conductors" on page 32.



Modular terminal blocks with fixing flange, series 264

WAGO Front-entry

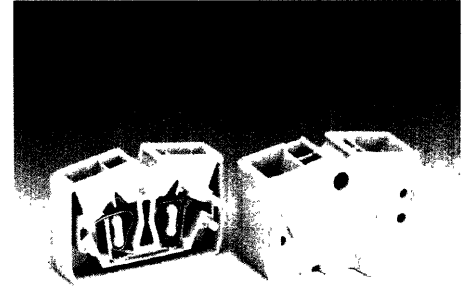
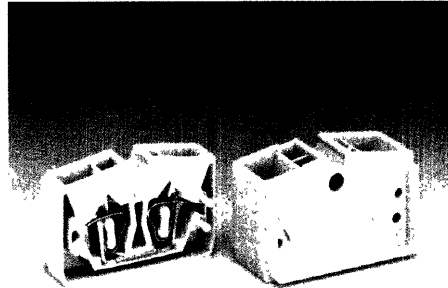

	AWG 26 – 14 600 V 600 V Term. bl. w. 0.236/0.393 in (6/10 mm) Stripped length 0.35 in (8 – 9 mm)	0.08 – 2.5 mm² 750 V~, Gr. C 26 A	AWG 26 – 14 600 V 600 V Term. bl. w. 0.236/0.393 in (6/10 mm) Stripped length 0.35 in (8 – 9 mm)	0.08 – 2.5 mm² 750 V~, Gr. C 26 A
--	---	---	---	---



suitable for EEx i-applications

Description	Colour	Item-No.	Pack.-unit pcs.	Colour	Item-No.	Pack.-unit pcs.
 Center terminal blocks, required for terminal block strips with fixing flanges between end plate and end terminals. (see also remarks concerning application)	2-conductor center terminal blocks 0.236 in (6 mm) wide			2-conductor end terminal blocks w. fixing flange 0.236 in (6 mm) wide		
	grey	264-321	100	grey	264-301	100
	blue	264-324	100	blue	264-304	100
	orange	264-326	100	orange	264-306	100
 End terminal blocks with fixing flange, for screw- or similar methods of fixing, fixing hole diameter 3.2 mm. (see also remarks concerning application)	4-conductor center terminal blocks 0.393 in (10 mm) wide			4-conductor end terminal blocks w. fixing flange 0.393 in (10 mm) wide		
	grey	264-351	100	grey	264-331	100
	blue	264-354	100	blue	264-334	100
	orange	264-356	100	orange	264-336	100
	green-yellow	264-357	100	green-yellow	264-337	100

Accessories for modular terminal blocks and terminal block strips (Marking accessories see page 7)

 End plate with fixing flange grey	0.157 in (4 mm) thick	264-361	25	0.157 in (4 mm) thick	264-361	25
 Comb-type jumper bar, 2-pole insulated, grey $I_N = 15 A$		264-402	200 (8 x 25)		264-402	200 (8 x 25)
 Operating tool, 2-pole, insulated, for connecting the comb-type jumper bar		280-432	1		280-432	1

Remarks concerning application (Dimensions see page 14)

Complete terminal block strip with fixing flanges, consisting of:

end plate with fixing flange

end terminal block with fixing flange

center terminal blocks



Terminal block strips with fixing flanges or snap-in mounting feet, series 264

WAGO Front-entry

	AWG 26 - 14 600 V 600 V Pole width 0.236 in (6 mm) Stripped length 0.35 in (8 - 9 mm)	0.08 - 2.5 mm² 750 V~, Gr. C 26 A	2 x AWG 26 - 14 600 V 600 V Pole width 0.393 in (10 mm) Stripped length 0.35 in (8 - 9 mm)	2 x 0.08 - 2.5 mm² 750 V~, Gr. C 26 A
--	--	---	---	---

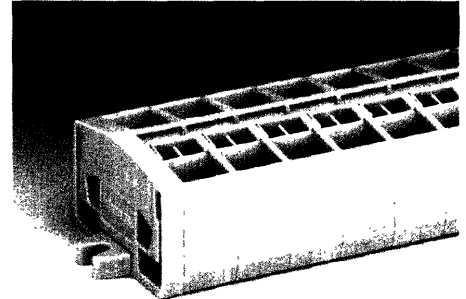
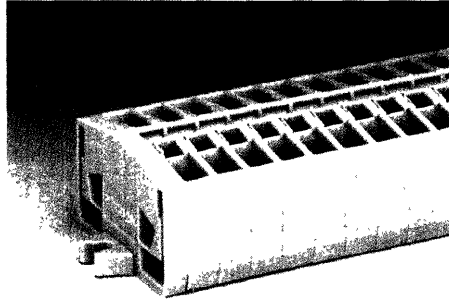

❶ For higher numbers of poles and/or terminal block strips with mixed colours acc. to customer's specification, please see page 30.

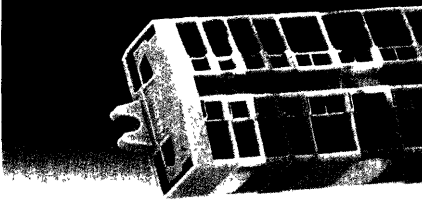
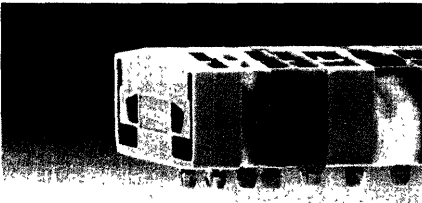
Description	No. of poles	Item-No.	Pack.-unit pcs.	No. of poles	Item-No.	Pack.-unit pcs.
 <p>Terminal block strips with fixing flanges, for screw- or similar methods of fixing, fixing hole diameter 3.2 mm</p>	2-conductor terminal block strips w. fixing flanges			4-conductor terminal block strips w. fixing flange		
	grey			grey		
	2	264-102		2	264-202	
	3	264-103		3	264-203	
	4	264-104		4	264-204	
	5	264-105		5	264-205	
	6	264-106		6	264-206	
	7	264-107		7	264-207	
	8	264-108		8	264-208	
	9	264-109		9	264-209	
	10	264-110		10	264-210	
	11	264-111		11	264-211	
12 ❶	264-112		12 ❶	264-212		
 <p>Terminal block strips with snap-in mounting feet, for plate thickness 0.6 - 1.2 mm, fixing hole diameter 3.5 mm, (also on aluminium rail 210-154 or with mounting adapter 209-120 on rail TS 35)</p>	2-cond. term. block strips w. snap-in mount. feet			4-cond. term. block strips w. snap-in mount. feet		
	grey			grey		
	2	264-152		2	264-252	
	3	264-153		3	264-253	
	4	264-154		4	264-254	
	5	264-155		5	264-255	
	6	264-156		6	264-256	
	7	264-157		7	264-257	
	8	264-158		8	264-258	
	9	264-159		9	264-259	
	10	264-160		10	264-260	
	11	264-161		11	264-261	
12 ❶	264-162		12 ❶	264-262		

Dimensions for modular terminal blocks and terminal block strips (in mm)

Modular terminal blocks and terminal block strips with fixing flanges

$L = \text{No. of poles} \times \text{pitch}$
 $L_1 = L + 9.6 \text{ mm}$
 $L_2 = L + 16 \text{ mm}$

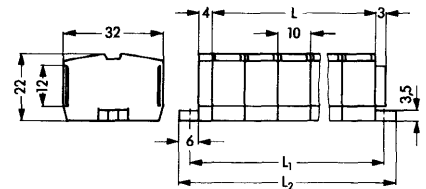
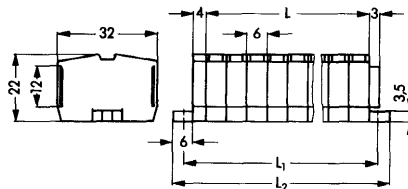

Modular terminal blocks and terminal block strips with snap-in mounting feet

$L = (\text{No. of poles} \times \text{pitch}) + 7 \text{ mm}$

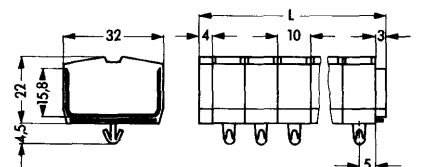
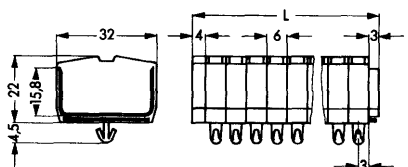

Modular terminal blocks with snap-in mounting foot, series 264

WAGO Front-entry



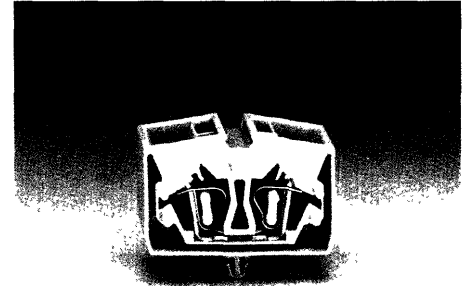
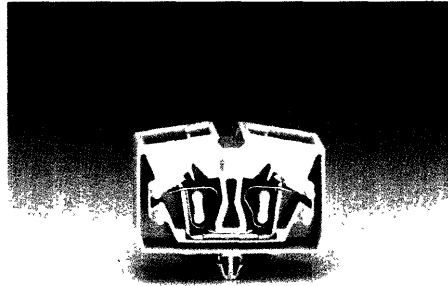



	AWG 26 – 14 600 V 600 V Terminal block width 0.236 in (6 mm) Stripped length 0.35 in (8 – 9 mm)	0.08 – 2.5 mm² 750 V~, Gr. C 26 A	2 x AWG 26 – 14 600 V 600 V Terminal block width 0.393 in (10 mm) Stripped length 0.35 in (8 – 9 mm)	2 x 0.08 – 2.5 mm² 750 V~, Gr. C 26 A
--	--	---	---	---



● suitable for EEx i-applications

Description	Colour	Item-No.	Pack.-unit pcs.	Colour	Item-No.	Pack.-unit pcs.
 Terminal blocks with snap-in mounting foot , for plate thickness 0.6 – 1.2 mm, fixing hole diameter 3.5 mm, (also on aluminium rail 210-154 or with mounting adapter 209-120 on TS 35)	2-conductor term. blocks w. snap-in mount. foot 0.236 in (6 mm) wide			4-conductor term. blocks w. snap-in mount. foot 0.393 in (10 mm) wide		
	grey	264-311	100	grey	264-341	100
	blue	264-314 ●	100	blue	264-344 ●	100
	orange	264-316	100	orange	264-346	100
	green-yellow	264-317	100	green-yellow	264-347	100

Accessories for modular terminal blocks and terminal block strips (Marking accessories see page 7)

 End plate , for terminal blocks with snap-in mounting foot grey	0.157 in (4 mm) thick 264-371	25	0.157 in (4 mm) thick 264-371	25
 Comb-type jumper bar , 2-pole insulated, grey $I_N = 15 A$	264-402	200 (8 x 25)	264-402	200 (8 x 25)
 Operating tool , 2-pole insulated, for connecting the comb-type jumper bar	280-432	1	280-432	1
 Aluminium carrier rail 3'3" x 0.71 in x 0.276 in 1000 x 18 x 7 mm	210-154	1	210-154	1
 Plastic end stop , with WSB marking facility, for aluminium rail 210-154 grey	0.236 in (6 mm) wide 209-122	25	0.236 in (6 mm) wide 209-122	25
 Mounting adapter for terminal blocks with snap-in mounting foot, for rail TS 35	209-120	25	209-120	25
 Mounting adapter for TS 35, can be used as end stop grey	0.256 in (6.5 mm) wide 209-137	25	0.256 in (6.5 mm) wide 209-137	25

EEx e II-Modular terminal blocks with fixing flange, series 264

WAGO Front-entry





AWG 16 (1.5 mm²) ①
250 V~
16 A
Term. bl. w. 0-236/0-393 in (6/10 mm)
Stripped length 0-35 in (8 – 9 mm)
PTB-certificate: in preparation

AWG 16 (1.5 mm²) ①
250 V~
16 A
Term. bl. w. 0-236/0-393 in (6/10 mm)
Stripped length 0-35 in (8 – 9 mm)
PTB-certificate: in preparation

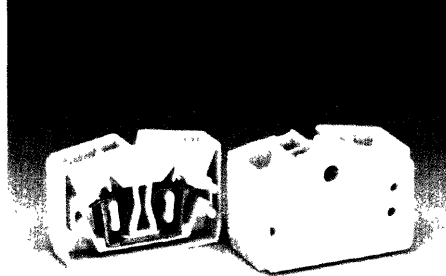

Modular terminal blocks with fixing flange for EEx i-applications see page 12.



① The cross-sections refer to conductors without and with gastight crimped ferrules. For types of conductors and their preparation see page 33 extract from "Electrical equipment for hazardous environments".

Description	Colour	Item-No.	Pack.-unit pcs.	Colour	Item-No.	Pack.-unit pcs.
 <p>Center terminal blocks, required for terminal block strips with fixing flange between end plate and end terminals. (see also remarks concerning application)</p>		2-conductor-center terminal blocks 0-236 in (6 mm) wide			2-conductor end terminal blocks w. fixing flange 0-236 in (6 mm) wide	
	light grey	264-131	100	light grey	264-130	100
 <p>End terminal blocks with fixing flange, for screw- or similar methods of fixing, fixing hole diameter 3.2 mm. (see also remarks concerning application)</p>		4-conductor-center terminal blocks 0-393 in (10 mm) wide			4-conductor end terminal blocks w. fixing flange 0-393 in (10 mm) wide	
	light grey	264-231	100	light grey	264-230	100

Accessories for modular terminal blocks and terminal block strips (Marking accessories see page 7)

 <p>End plate with fixing flange grey</p>	0-157 in (4 mm) thick	264-361	25	0-157 in (4 mm) thick	264-361	25
 <p>Comb-type jumper bar, 2-pole insulated, grey I_N = 15 A</p>		264-402	200 (8 x 25)		264-402	200 (8 x 25)
 <p>Operating tool, 2-pole, insulated, for connecting the comb-type jumper bar</p>		280-432	1		280-432	1

--	--	--	--	--	--	--

Remarks concerning application (Dimensions see page 14)

Complete EEx e II-terminal block strip with fixing flanges, consisting of:

end plate with fixing flange

end terminal block with fixing flange

center terminal blocks

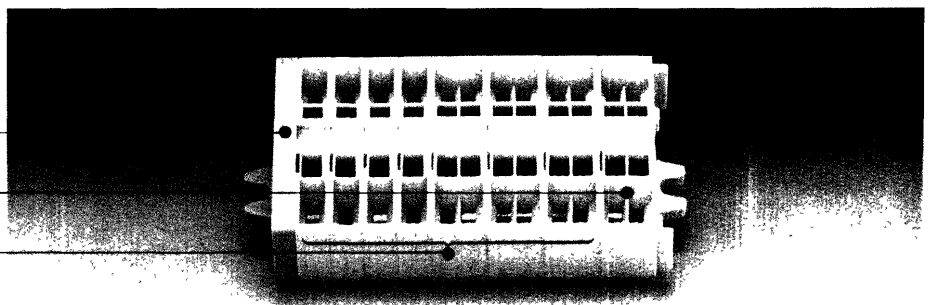

EEx e II-Modular terminal blocks with snap-in mounting foot, series 264

WAGO Front-entry

	<p>AWG 16 (1.5 mm²) ① 250 V~ 16 A Terminal block width 0.236 in (6 mm) Stripped length 0.35 in (8 – 9 mm) PTB-certificate: in preparation</p>	<p>2 x AWG 16 (2 x 1.5 mm²) ① 250 V~ 16 A Terminal block width 0.393 in (10 mm) Stripped length 0.35 in (8 – 9 mm) PTB-certificate: in preparation</p>
--	---	--



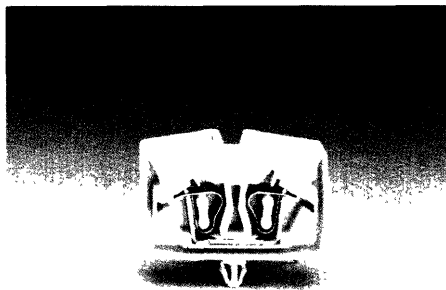



Modular terminal blocks with snap-in mounting foot for EEx i-applications see page 13.



① The cross-sections refer to conductors without and with gastight crimped ferrules. For types of conductors and their preparation see page 33 extract from "Electrical equipment for hazardous environments".

Description	Colour	Item-No.	Pack.-unit pcs.	Colour	Item-No.	Pack.-unit pcs.	
 <p>Terminal blocks with snap-in mounting foot, for plate thickness 0.6 – 1.2 mm, fixing hole diameter 3.5 mm, (also on aluminium rail 210-154 or with mounting adapter 209-120 on TS 35)</p>	light grey	264-180	100	light grey	264-280	100	
2-conductor term. blocks w. snap-in mount. foot 0.236 in (6 mm) wide				4-conductor term. blocks w. snap-in mount. foot 0.393 in (10 mm) wide			

Accessories for modular terminal blocks and terminal block strips (Marking accessories see page 7)

	<p>End plate, for terminal blocks with snap-in mounting foot grey</p>	0.157 in (4 mm) thick	264-371	25	0.157 in (4 mm) thick	264-371	25
	<p>Comb-type jumper bar, 2-pole insulated, grey $I_N = 15 A$</p>		264-402	200 (8 x 25)		264-402	200 (8 x 25)
	<p>Operating tool, 2-pole insulated, for connecting the comb-type jumper bar</p>		280-432	1		280-432	1
	<p>Aluminium carrier rail 3"3' x 0.71 in x 0.276 in 1000 x 18 x 7 mm</p>		210-154	1		210-154	1
	<p>Plastic end stop, with WSB marking facility, for aluminium rail 210-154 grey</p>	0.236 in (6 mm) wide	209-122	25	0.236 in (6 mm) wide	209-122	25
	<p>Mounting adapter for terminal blocks with snap-in mounting foot, for rail TS 35</p>		209-120	25		209-120	25
	<p>Mounting adapter for TS 35, can be used as end stop grey</p>	0.256 in (6.5 mm) wide	209-137	25	0.256 in (6.5 mm) wide	209-137	25

EEx e II-Terminal block strips w. fixing flanges or snap-in mounting feet, series 264

WAGO Front-entry



AWG 16 (1.5 mm²) ①
250 V~
16 A
Pole width 0.236 in (6 mm)
Stripped length 0.35 in (8 - 9 mm)
PTB-certificate: in preparation

2 x AWG 16 (2 x 1.5 mm²) ①
250 V~
16 A
Pole width 0.393 in (10 mm)
Stripped length 0.35 in (8 - 9 mm)
PTB-certificate: in preparation

① The cross-sections refer to conductors without and with gastight crimped ferrules. For types of conductors and their preparation see page 33 extract from "Electrical equipment for hazardous environments".

② For higher numbers of poles acc. to customer's specification please see page 30

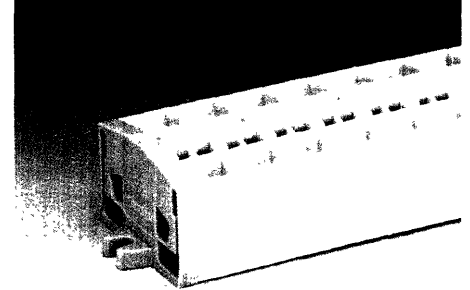
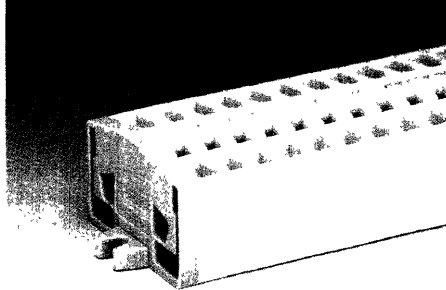

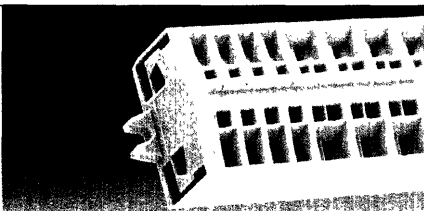
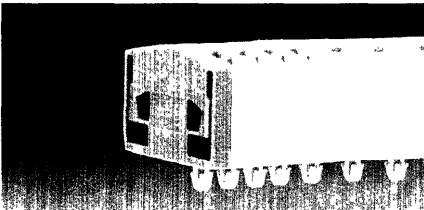
Description	No. of poles	Item-No.	Pack.-unit pcs.	No. of poles	Item-No.	Pack.-unit pcs.
 <p>Terminal block strips with fixing flanges, for screw- or similar methods of fixing, fixing hole diameter 3.2 mm</p>	2-conductor terminal block strips w. fixing flanges			4-conductor terminal block strips w. fixing flanges		
		light grey		light grey		
	2	264-132		2	264-232	
	3	264-133		3	264-233	
	4	264-134		4	264-234	
	5	264-135		5	264-235	
	6	264-136		6	264-236	
	7	264-137		7	264-237	
	8	264-138		8	264-238	
	9	264-149		9	264-239	
	10	264-140		10	264-240	
	11	264-141		11	264-241	
12 ②	264-142		12 ②	264-242		
 <p>Terminal block strips with snap-in mounting feet, for plate thickness 0.6 - 1.2 mm, fixing hole diameter 3.5 mm, (also on aluminium rail 210-154 or with mounting adapter 209-120 on rail TS 35)</p>	2-cond. term. block strips w. snap-in mount. feet			4-cond. term. block strips w. snap-in mount. feet		
		light grey		light grey		
	2	264-182		2	264-282	
	3	264-183		3	264-283	
	4	264-184		4	264-284	
	5	264-185		5	264-285	
	6	264-186		6	264-286	
	7	264-187		7	264-287	
	8	264-188		8	264-288	
	9	264-189		9	264-289	
	10	264-190		10	264-290	
	11	264-191		11	264-291	
12 ②	264-192		12 ②	264-292		

Dimensions for modular terminal blocks and terminal block strips (in mm)

Modular terminal blocks and terminal block strips with fixing flanges

L = No. of poles x pitch
 L₁ = L + 9.6 mm
 L₂ = L + 16 mm

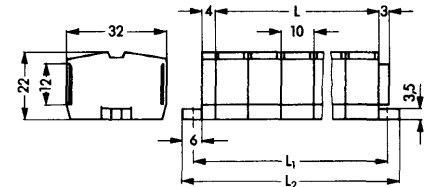
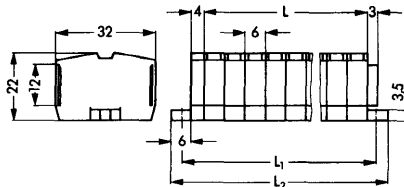

Modular terminal blocks and terminal block strips with snap-in mounting feet



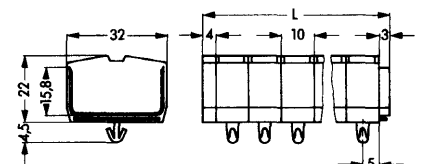
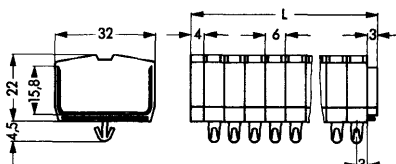





















L = (No. of poles x pitch) + 7 mm









Modular terminal blocks with fixing flange or snap-in mounting foot, series 260

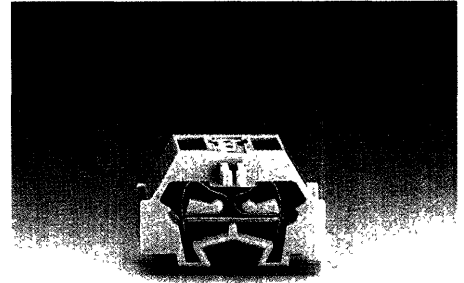
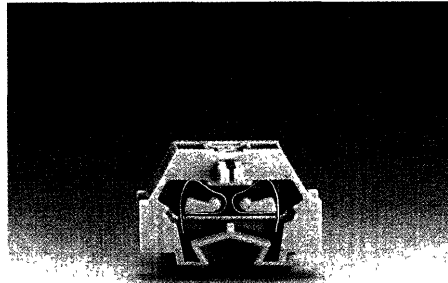



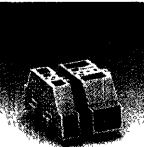



WAGO Side-entry

<p>AWG 26 - 16 0.08 - 1.5 mm² 300 V, 10 A  500/380 V~, Gr. B/C 300 V, 10 A  18 A Terminal block width 0.196 in (5 mm) Stripped length 0.35 in (8 - 9 mm)</p> <p><small>*          LR GL BV </small></p>	<p>2 x AWG 26 - 16 2 x 0.08 - 1.5 mm² 300 V, 10 A  500/380 V~, Gr. B/C 300 V, 10 A  18 A Terminal block width 0.315 in (8 mm) Stripped length 0.35 in (8 - 9 mm)</p> <p><small>*          LR GL BV </small></p>
--	--



Description	Colour	Item-No.	Pack.-unit pcs.	Colour	Item-No.	Pack.-unit pcs.
 <p>Terminal blocks with fixing flange, for screw- or similar methods of fixing, fixing hole diameter 3.2 mm (with mounting adapter 209-123 also on rail TS 35)</p>	2-conductor terminal blocks			4-conductor terminal blocks		
	grey	260-301	300 (6 x 50)	grey	260-331	300 (6 x 50)
	light grey	260-303	300 (6 x 50)	light grey	260-333	300 (6 x 50)
	blue	260-304	300 (6 x 50)	blue	260-334	300 (6 x 50)
	orange	260-306	300 (6 x 50)	orange	260-336	300 (6 x 50)
 <p>Terminal blocks with snap-in mounting foot, for plate thickness 0.6 - 1.2 mm, fixing hole diameter 3.5 mm, (also on aluminium rail 210-154 or with mounting adapter 209-120 on rail TS 35)</p>	2-conductor terminal blocks			4-conductor terminal blocks		
	grey	260-311	300 (6 x 50)	grey	260-341	300 (6 x 50)
	light grey	260-313	300 (6 x 50)	light grey	260-343	300 (6 x 50)
	blue	260-314	300 (6 x 50)	blue	260-344	300 (6 x 50)
	orange	260-316	300 (6 x 50)	orange	260-346	300 (6 x 50)
 <p>End terminal block,  without fixing foot, for terminal block strips with snap-in mounting feet (see dimensioned drawings on page 21 and example of an assembly on page 31)</p>	2-conductor terminal blocks			4-conductor terminal blocks		
	grey	260-321	300 (6 x 50)	grey	260-351	300 (6 x 50)
	light grey	260-323	300 (6 x 50)	light grey	260-353	300 (6 x 50)
	blue	260-324	300 (6 x 50)	blue	260-354	300 (6 x 50)
	orange	260-326	300 (6 x 50)	orange	260-356	300 (6 x 50)
	green-yellow	260-327	300 (6 x 50)	green-yellow	260-357	300 (6 x 50)

Accessories for modular terminal blocks and terminal block strips (Marking accessories see pages 28 - 29)

 <p>End plate with fixing flange grey</p>	260-361	100 (2 x 50)	260-361	100 (2 x 50)
 <p>End plate with snap-in mounting foot grey</p>	260-371	100 (2 x 50)	260-371	100 (2 x 50)
 <p>Comb-type jumper bar, insulated, 2-pole, $I_N = 10 A$ grey</p>	260-402	25	260-402	25
 <p>Operating tool, insulated, for connecting the comb-type jumper bar</p>	209-132	1	209-132	1
 <p>Aluminium carrier rail, 3"3' x 0.71 in x 0.276 in 1000 x 18 x 7 mm</p>	210-154	1	210-154	1
 <p>Plastic end stop, with WSB marking facility, for aluminium rail 210-154 grey</p>	0.236 in (6 mm) wide 209-122	25	0.236 in (6 mm) wide 209-122	25
 <p>Mounting adapter, for terminal blocks with snap-in mounting foot, for TS 35</p>	209-120	25	209-120	25
 <p>Mounting adapter with screw, for terminal blocks with fixing flange, for TS 35</p>	209-123	25	209-123	25
 <p>Mounting adapter for TS 35, can be used as end stop grey</p>	0.256 in (6.5 mm) wide 209-137	25	0.256 in (6.5 mm) wide 209-137	25

* For approvals with the corresponding nominal data please see pages 34 - 35.

Description and handling Modular terminal blocks and terminal block strips with cage-clamp spring Series 260, 261 and 262

WAGO Side-entry

Marking with self-adhesive marker strips

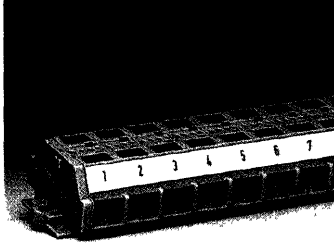

Marking with marker bars

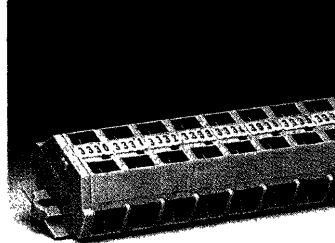

Marking by direct printing

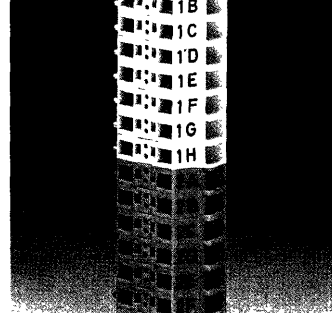

Terminal block strips with fixing flanges, screw-fixing of mount, adapter 209-123*

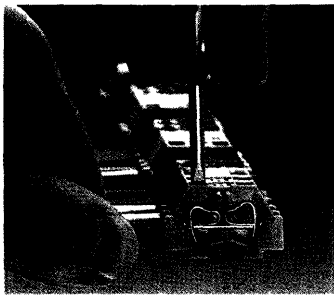

Connection of conductors

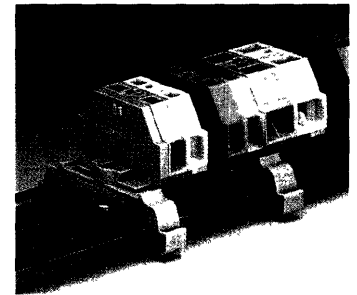
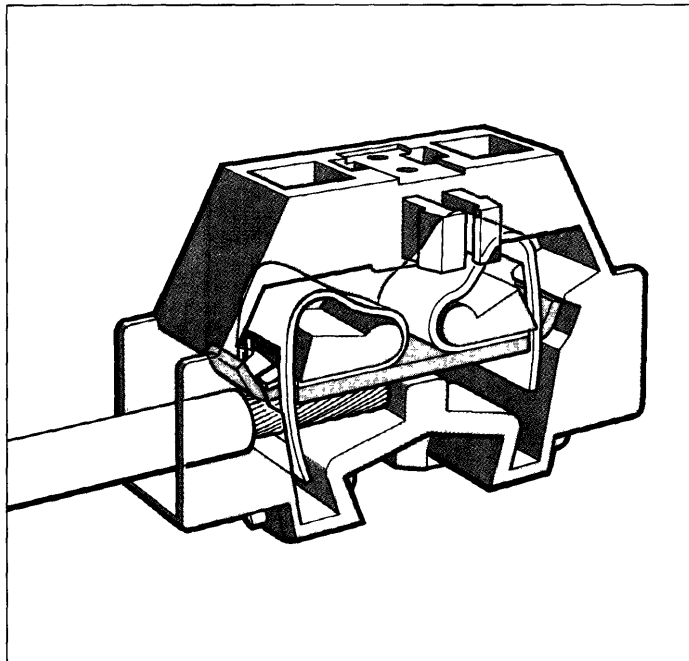

Terminal block strips with fixing flanges on carrier rail TS 35

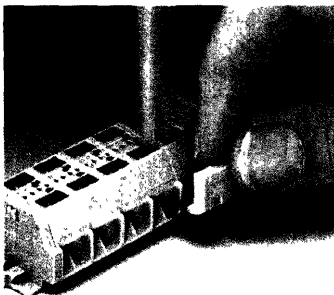

Commoning with jumper bars



Terminal block strips with snap-in mounting feet, ass. of mounting adapter 209-120*

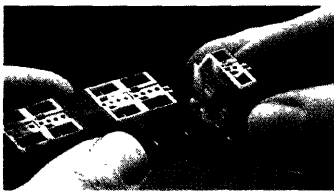

Assembly of modular terminal blocks to terminal block strips

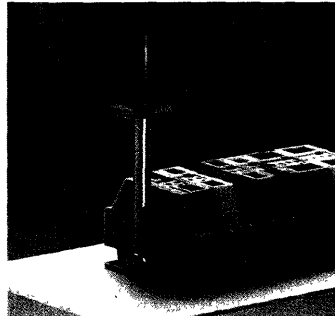

Terminal block strips with fixing flanges, screw-fixing

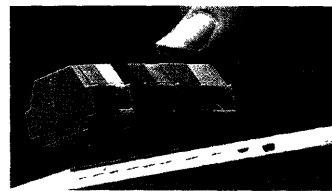

Terminal block strips with snap-in mounting feet, hole-fixing

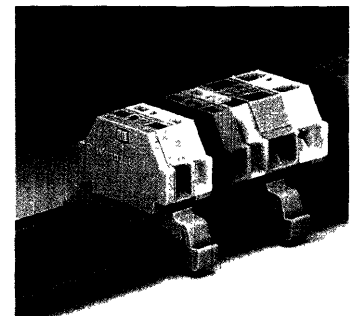

Terminal block strips with snap-in mounting feet on carrier rail TS 35

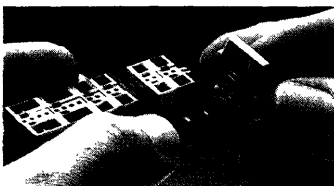

Mounting of end plate

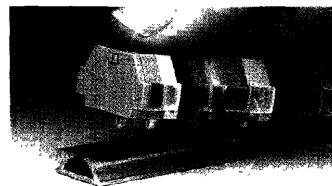

Terminal block strips with snap-in mounting feet on special aluminium carrier rail

* The distance between mounting adapters/ feet should be approx. 1.38 - 1.57 in (35 - 40 mm)

The cage-clamp spring clamps the following copper conductors:

For aluminium conductors please refer to the remarks on page 32!



solid



stranded**



flexible**



flexible with ferrule (gastight crimped) ①





flexible with pin terminal (gastight crimped)

① When using ferrules, the maximum conductor cross-section which can be accommodated is one size below the nominal cross-section rating of the terminal block. (Except for EEx e II-terminal blocks, where this has been allowed for!)

** If used in a corrosive atmosphere, please refer to the information concerning "Connection of flexible conductors" on page 32.

Terminal block strips with fixing flanges or snap-in mounting feet, series 260

WAGO Side-entry

<p>AWG 26 - 16 0.08 - 1.5 mm² 300 V, 10 A 500/380 V~, Gr. B/C 300 V, 10 A 18 A Pole width 0.196 in (5 mm) Stripped length 0.35 in (8 - 9 mm)</p>	<p>2 x AWG 26 - 16 2 x 0.08 - 1.5 mm² 300 V, 10 A 500/380 V~, Gr. B/C 300 V, 10 A 18 A Pole width 0.315 in (8 mm) Stripped length 0.35 in (8 - 9 mm)</p>
* 	* 

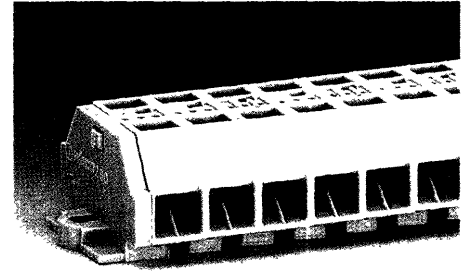
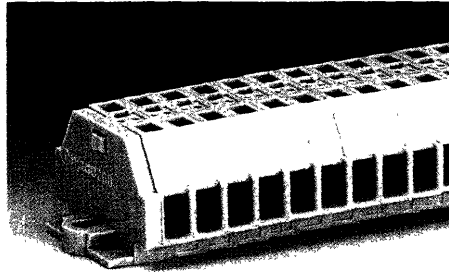

① For higher numbers of poles and/or terminal block strips with mixed colours acc. to customer's specification, please see page 30

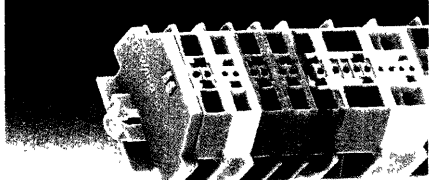
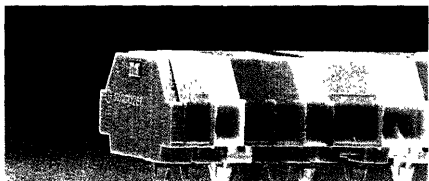
Description	No. of poles	Item-No.	Pack.-unit pcs.	No. of poles	Item-No.	Pack.-unit pcs.
 Terminal block strips with fixing flanges, for screw- or similar methods of fixing, fixing hole diameter 3.2 mm (with mounting adapter 209-123 also on rail TS 35)	2-conductor terminal block strips with fixing flanges, grey			4-conductor terminal block strips with fixing flanges, grey		
	2	260-102	100	2	260-202	100
	3	260-103	100	3	260-203	100
	4	260-104	100	4	260-204	100
	5	260-105	100	5	260-205	100
	6	260-106	50	6	260-206	50
	7	260-107	50	7	260-207	50
	8	260-108	50	8	260-208	50
	9	260-109	50	9	260-209	50
	10	260-110	25	10	260-210	25
	11	260-111	25	11	260-211	25
	12 ①	260-112	25	12 ①	260-212	25
 Terminal block strips with snap-in mounting feet, for plate thickness 0.6 - 1.2 mm, fixing hole diameter 3.5 mm, (also on aluminium rail 210-154 or with mounting adapter 209-120 on rail TS 35)	2-conductor terminal block strips with snap-in mounting feet, grey			4-conductor terminal block strips with snap-in mounting feet, grey		
	2	260-152	100	2	260-252	100
	3	260-153	100	3	260-253	100
	4	260-154	100	4	260-254	100
	5	260-155	100	5	260-255	100
	6	260-156	50	6	260-256	50
	7	260-157	50	7	260-257	50
	8	260-158	50	8	260-258	50
	9	260-159	50	9	260-259	50
	10	260-160	25	10	260-260	25
	11	260-161	25	11	260-261	25
	12 ①	260-162	25	12 ①	260-262	25

Dimensions for modular terminal blocks and terminal block strips (in mm)

Modular terminal blocks and terminal block strips with fixing flanges

$L = \text{No. of poles} \times \text{pitch}$
 $L_1 = L + 8.1 \text{ mm}$
 $L_2 = L + 14.5 \text{ mm}$

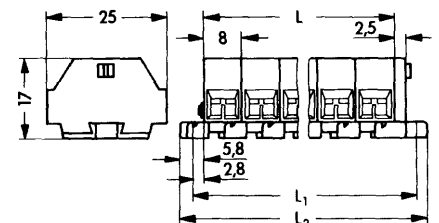
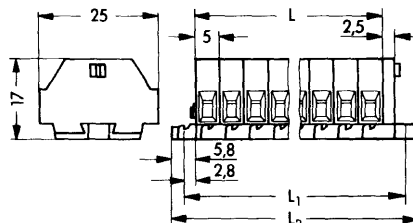

Modular terminal blocks and terminal block strips with snap-in mounting feet





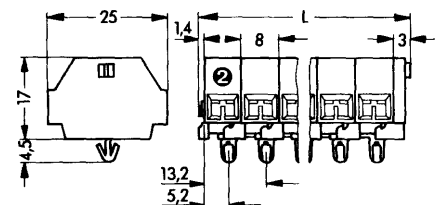
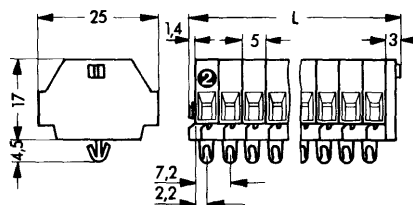



















② End terminal block; see page 20 and example of an assembly on page 31

$L = (\text{No. of poles} \times \text{pitch}) + 4.4 \text{ mm}$





Modular terminal blocks with fixing flange or snap-mounting foot, series 261



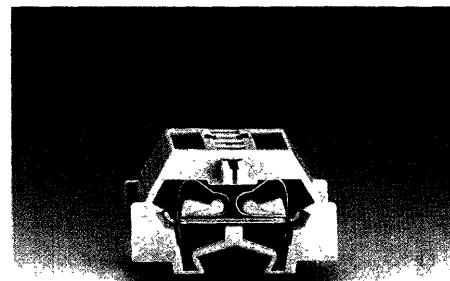
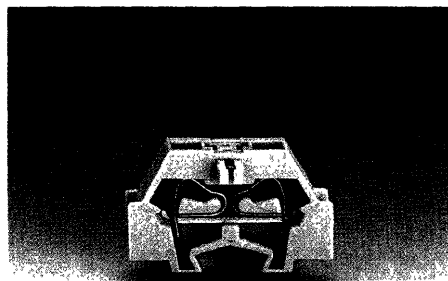

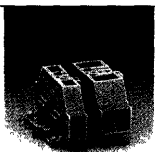
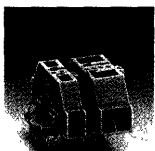
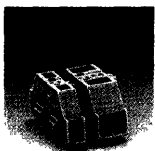



WAGO Side-entry

<p>AWG 26 - 14 0.08 - 2.5 mm² 300 V, 15 A  660/500 V~, Gr. B/C 300 V, 20 A  26 A Terminal block width 0.236 in (6 mm) Stripped length 0.35 in (8 - 9 mm)</p> <p><small>*          LR GL BV </small></p>	<p>2 x AWG 26 - 14 2 x 0.08 - 2.5 mm² 300 V, 15 A  660/500 V~, Gr. B/C 300 V, 20 A  26 A Terminal block width 0.393 in (10 mm) Stripped length 0.35 in (8 - 9 mm)</p> <p><small>*          LR GL BV </small></p>
---	--



Description	Colour	Item-No.	Pack.-unit pcs.	Colour	Item-No.	Pack.-unit pcs.
 <p>Terminal blocks with fixing flange, for screw- or similar methods of fixing, fixing hole diameter 3.2 mm (with mounting adapter 209-123 also on rail TS 35)</p>	2-conductor terminal blocks			4-conductor terminal blocks		
	grey	261-301	200 (4 x 50)	grey	261-331	200 (4 x 50)
	light grey	261-303	200 (4 x 50)	light grey	261-333	200 (4 x 50)
	blue	261-304	200 (4 x 50)	blue	261-334	200 (4 x 50)
	orange	261-306	200 (4 x 50)	orange	261-336	200 (4 x 50)
 <p>Terminal blocks with snap-in mounting foot, for plate thickness 0.6 - 1.2 mm, fixing hole diameter 3.5 mm, (also on aluminium rail 210-154 or with mounting adapter 209-120 on rail TS 35)</p>	2-conductor terminal blocks			4-conductor terminal block		
	grey	261-311	200 (4 x 50)	grey	261-341	200 (4 x 50)
	light grey	261-313	200 (4 x 50)	light grey	261-343	200 (4 x 50)
	blue	261-314	200 (4 x 50)	blue	261-344	200 (4 x 50)
	orange	261-316	200 (4 x 50)	orange	261-346	200 (4 x 50)
 <p>End terminal block,  without fixing foot, for terminal block strips with snap-in mounting feet (see dimensioned drawings on page 23 and example of an assembly on page 31)</p>	2-conductor terminal blocks			4-conductor terminal blocks		
	grey	261-321	200 (4 x 50)	grey	261-351	200 (4 x 50)
	light grey	261-323	200 (4 x 50)	light grey	261-353	200 (4 x 50)
	blue	261-324	200 (4 x 50)	blue	261-354	200 (4 x 50)
	orange	261-326	200 (4 x 50)	orange	261-356	200 (4 x 50)
green-yellow	261-327	200 (4 x 50)	green-yellow	261-357	200 (4 x 50)	



















































Accessories for modular terminal blocks and terminal block strips (Marking accessories see pages 28 - 29)

 <p>End plate with fixing flange grey</p>	261-361	100 (2 x 50)	261-361	100 (2 x 50)
 <p>End plate with snap-in mounting foot grey</p>	261-371	100 (2 x 50)	261-371	100 (2 x 50)
 <p>Comb-type jumper bar, insulated, 2-pole, $I_N = 15 A$ grey</p>	261-402	25	261-402	25
 <p>Operating tool, insulated, for connecting the comb-type jumper bar</p>	209-132	1	209-132	1
 <p>Aluminium carrier rail, 3"3' x 0.71 in x 0.276 in 1000 x 18 x 7 mm</p>	210-154	1	210-154	1
 <p>Plastic end stop, with WSB marking facility, for aluminium rail 210-154 grey</p>	0.236 in (6 mm) wide 209-122	25	0.236 in (6 mm) wide 209-122	25
 <p>Mounting adapter, for terminal blocks with snap-in mounting foot, for TS 35</p>	209-120	25	209-120	25
 <p>Mounting adapter with screw, for terminal blocks with fixing flange, for TS 35</p>	209-123	25	209-123	25
 <p>Mounting adapter for TS 35, can be used as end stop grey</p>	0.256 in (6.5 mm) wide 209-137	25	0.256 in (6.5 mm) wide 209-137	25

* For approvals with the corresponding nominal data please see pages 34 - 35.

Terminal block strips with fixing flanges or snap-in mounting feet, series 261

WAGO Side-entry

AWG 26 -14 300 V, 15 A  300 V, 20 A  Pole width 0.236 in (6 mm) Stripped length 0.35 in (8 - 9 mm)	0.08 - 2.5 mm² 660/500V~, Gr.B/C 26 A	2 x AWG 26 - 14 2 x 0.08 - 2.5 mm² 300 V, 15 A  660/500V~, Gr.B/C 300 V, 20 A  26 A Pole width 0.393 in (10 mm) Stripped length 0.35 in (8 - 9 mm)	
*                               		*                	

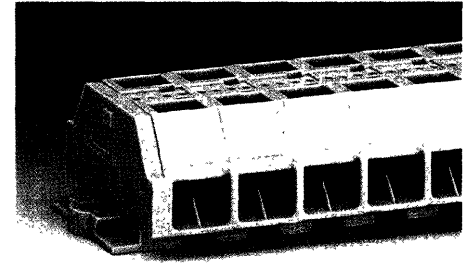
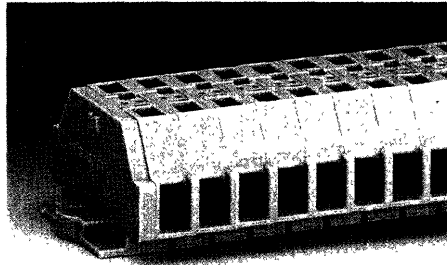

! For higher numbers of poles and/or terminal block strips with mixed colours acc. to customer's specification, please see page 30

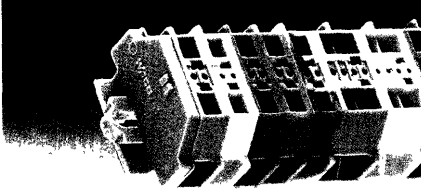
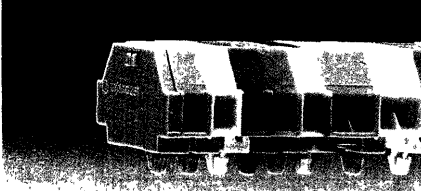
Description	No. of poles	Item-No.	Pack.-unit pcs.	No. of poles	Item-No.	Pack.-unit pcs.
 Terminal block strips with fixing flanges, for screw- or similar methods of fixing, fixing hole diameter 3.2 mm (with mounting adapter 209-123 also on rail TS 35)	2-conductor terminal block strips with fixing flanges, grey			4-conductor terminal block strips with fixing flanges, grey		
	2	261-102	100	2	261-202	100
	3	261-103	100	3	261-203	100
	4	261-104	100	4	261-204	100
	5	261-105	100	5	261-205	100
	6	261-106	50	6	261-206	50
	7	261-107	50	7	261-207	50
	8	261-108	50	8	261-208	50
	9	261-109	50	9	261-209	50
	10	261-110	25	10	261-210	25
	11	261-111	25	11	261-211	25
	12 !	261-112	25	12 !	261-212	25
 Terminal block strips with snap-in mounting feet, for plate thickness 0.6 - 1.2 mm, fixing hole diameter 3.5 mm, (also on aluminium rail 210-154 or with mounting adapter 209-120 on rail TS 35)	2-conductor terminal block strips with snap-in mounting feet, grey			4-conductor terminal block strips with snap-in mounting feet, grey		
	2	261-152	100	2	261-252	100
	3	261-153	100	3	261-253	100
	4	261-154	100	4	261-254	100
	5	261-155	100	5	261-255	100
	6	261-156	50	6	261-256	50
	7	261-157	50	7	261-257	50
	8	261-158	50	8	261-258	50
	9	261-159	50	9	261-259	50
	10	261-160	25	10	261-260	25
	11	261-161	25	11	261-261	25
	12 !	261-162	25	12 !	261-262	25

Dimensions for modular terminal blocks and terminal block strips (in mm)

Modular terminal blocks and terminal block strips with fixing flanges

$L = \text{No. of poles} \times \text{pitch}$
 $L_1 = L + 8.1 \text{ mm}$
 $L_2 = L + 14.5 \text{ mm}$

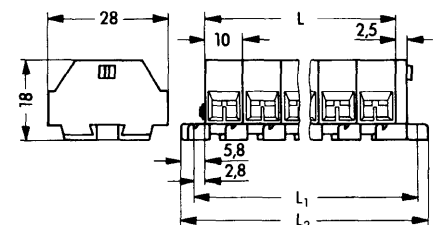
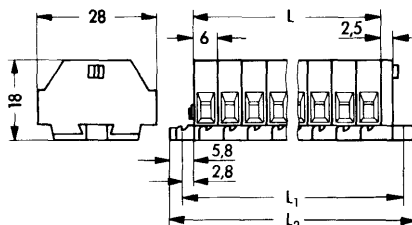

Modular terminal blocks and terminal block strips with snap-in mounting feet

! End terminal block; see page 22 and example of an assembly on page 31

$L = (\text{No. of poles} \times \text{pitch}) + 4.4 \text{ mm}$

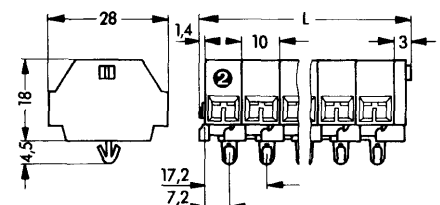
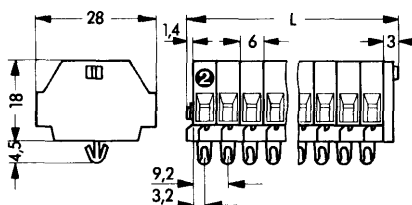

Modular terminal blocks with fixing flange or snap-in mounting foot, series 262

WAGO Side-entry

	AWG 26 - 12 0.08 - 4 mm² 300 V, 20 A 1000/660 V~ , Gr. B/C 300 V, 25 A 26 A Terminal block width 0.276 in (7 mm) Stripped length 0.39 in (9 - 10 mm)	2 x AWG 26 - 12 2 x 0.08 - 4 mm² 300 V, 20 A 1000/660 V~ , Gr. B/C 300 V, 25 A 34 A Terminal block width 0.472 in (12 mm) Stripped length 0.39 in (9 - 10 mm)
	* LR GL BV	* LR GL BV

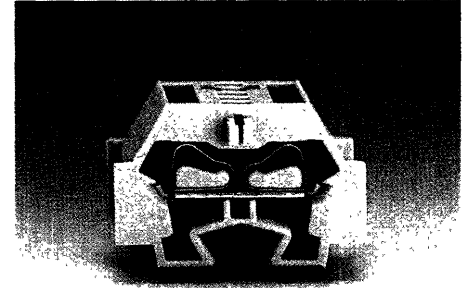
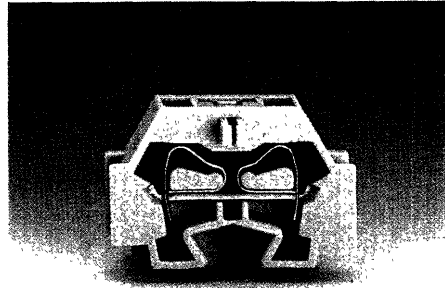

Suitable for EEx i-applications

Description	Colour	Item-No.	Pack.-unit pcs.	Colour	Item-No.	Pack.-unit pcs.		
Terminal blocks with fixing flange , for screw- or similar methods of fixing, fixing hole diameter 3.2 mm (with mounting adap. 209-123 also on rail TS 35)	2-conductor terminal blocks grey 262-301 100 (2 x 50) blue 262-304 100 (2 x 50) orange 262-306 100 (2 x 50) green-yellow 262-307 100 (2 x 50)			4-conductor terminal blocks grey 262-331 100 (2 x 50) blue 262-334 100 (2 x 50) orange 262-336 100 (2 x 50) green-yellow 262-337 100 (2 x 50)				
	Terminal blocks with snap-in mounting foot , for plate thickness 0.6 - 1.2 mm, fixing hole diameter 3.5 mm, (also on aluminium rail 210-154 or with mounting adapter 209-120 on rail TS 35)	2-conductor terminal blocks grey 262-311 100 (2 x 50) blue 262-314 100 (2 x 50) orange 262-316 100 (2 x 50) green-yellow 262-317 100 (2 x 50)			4-conductor terminal blocks grey 262-341 100 (2 x 50) blue 262-344 100 (2 x 50) orange 262-346 100 (2 x 50) green-yellow 262-347 100 (2 x 50)			
		End terminal block , without fixing foot, for terminal block strips with snap-in mounting foot (see dimensioned drawing on page 25 and example of an assembly on page 31)	2-conductor terminal blocks grey 262-321 100 (2 x 50) blue 262-324 100 (2 x 50) orange 262-326 100 (2 x 50) green-yellow 262-327 100 (2 x 50)			4-conductor terminal blocks grey 262-351 100 (2 x 50) blue 262-354 100 (2 x 50) orange 262-356 100 (2 x 50) green-yellow 262-357 100 (2 x 50)		





















Accessories for modular terminal blocks and terminal block strips (Marking accessories see pages 28 - 29)

End plate with fixing flange grey	262-361	50	262-361	50
End plate with snap-in mounting foot grey	262-371	50	262-371	50
Comb-type jumper bar , insulated, 2-pole, $I_N = 15 A$ grey	262-402	25	262-402	25
Operating tool , insulated, for connecting the comb-type jumper bar	209-132	1	209-132	1
Aluminium carrier rail , 3"3' x 0.71 in x 0.276 in 1000 x 18 x 7 mm	210-154	1	210-154	1
Plastic end stop , with WSB marking facility, for aluminium rail 210-154 grey	0.236 in (6 mm) wide 209-122	25	0.236 in (6 mm) wide 209-122	25
Mounting adapter , for terminal blocks with snap-in mounting foot, for TS 35	209-120	25	209-120	25
Mounting adapter with screw , for terminal blocks with fixing flange, for TS 35	209-123	25	209-123	25
Mounting adapter for TS 35 , can be used as end stop grey	0.256 in (6.5 mm) wide 209-137	25	0.256 in (6.5 mm) wide 209-137	25

* For approvals with the corresponding nominal data please see pages 34 - 35.

Terminal block strips with fixing flanges or snap-in mounting feet, series 262





WAGO Side-entry

AWG 26 - 12 300 V, 20 A  300 V, 25 A  Pole width 0.276 in (7 mm) Stripped length 0.39 in (9 - 10 mm)	0.08 - 4 mm² 1000/660 V~, Gr. B/C 26 A	2 x AWG 26 - 12 300 V, 20 A  300 V, 25 A  Pole width 0.472 in (12 mm) Stripped length 0.39 in (9 - 10 mm)	2 x 0.08 - 4 mm² 1000/660 V~, Gr. B/C 34 A
*         LR GL BV		*         LR GL BV	

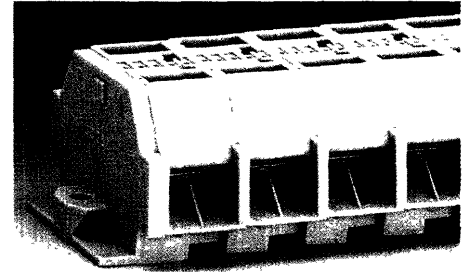
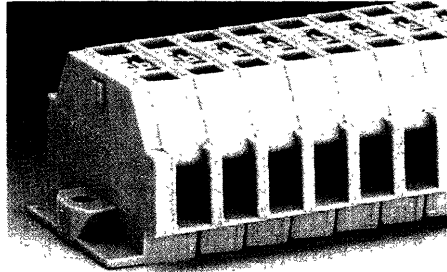
① For higher numbers of poles and/or terminal block strips with mixed colours acc. to customer's specification, please see page 30

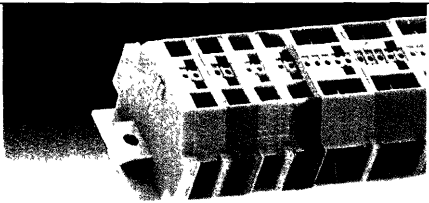
Suitable for EEx i-applications with blue insulating housings

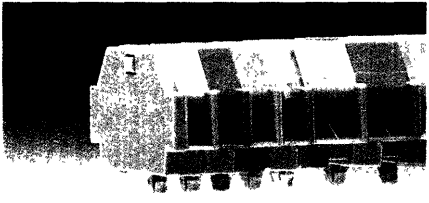

Description	No. of poles	Item-No.	Pack.-unit pcs.	No. of poles	Item-No.	Pack.-unit pcs.		
 <p>Terminal block strips with fixing flanges, for screw- or similar methods of fixing, fixing hole diameter 3.2 mm (with mounting adapter 209-123 also on rail TS 35)</p>	2-cond. terminal block strips with fixing flanges			4-cond. terminal block strips with fixing flanges				
	grey 				grey 			
	2	262-102	100	2	262-202	100		
	3	262-103	100	3	262-203	100		
	4	262-104	100	4	262-204	100		
	5	262-105	100	5	262-205	100		
	6	262-106	50	6	262-206	50		
	7	262-107	50	7	262-207	50		
	8	262-108	50	8	262-208	50		
	9	262-109	50	9	262-209	50		
	10	262-110	25	10	262-210	25		
	11	262-111	25	11	262-211	25		
12 ①	262-112	25	12 ①	262-212	25			
 <p>Terminal block strips with snap-in mounting feet, for plate thickness 0.6 - 1.2 mm, fixing hole diameter 3.5 mm, (also on aluminium rail 210-154 or with mounting adapter 209-120 on rail TS 35)</p>	2-cond. term. bl. strips with snap-in mount. feet			4-cond. term. bl. strips with snap-in mount. feet				
	grey 				grey 			
	2	262-152	100	2	262-252	100		
	3	262-153	100	3	262-253	100		
	4	262-154	100	4	262-254	100		
	5	262-155	100	5	262-255	100		
	6	262-156	50	6	262-256	50		
	7	262-157	50	7	262-257	50		
	8	262-158	50	8	262-258	50		
	9	262-159	50	9	262-259	50		
	10	262-160	25	10	262-260	25		
	11	262-161	25	11	262-261	25		
12 ①	262-162	25	12 ①	262-262	25			

Dimensions for modular terminal blocks and terminal block strips (in mm)

Modular terminal blocks and terminal block strips with fixing flange

L = No. of poles x pitch
 $L_1 = L + 8.1$ mm
 $L_2 = L + 14.5$ mm

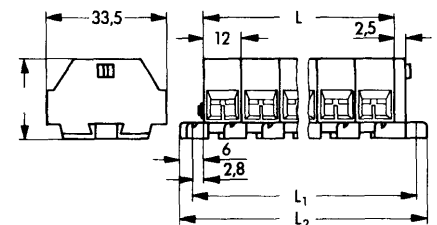
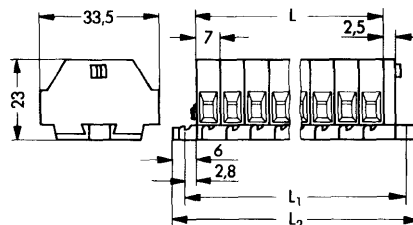

Modular terminal blocks and terminal block strips with snap-in mounting feet

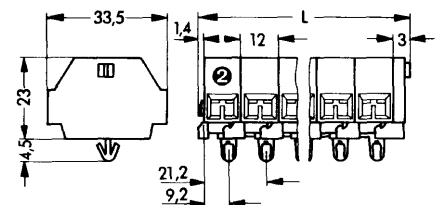
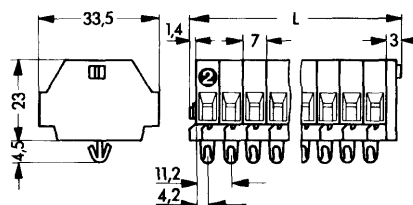

② End terminal block; see page 24 and example of an assembly on page 31

$L = (\text{No. of poles} \times \text{pitch}) + 4.4$ mm



EEx e II-modular term. blocks with fixing flange or snap-in mount. foot, series 262



WAGO Side-entry

	AWG 14 (2.5 mm²) ① 380 V~ 22 A Terminal block width 0.276 in (7 mm) Stripped length 0.39 in (9 - 10 mm) * PTB-certificate: Ex-88.B.3115 U		2 x AWG 14 (2 x 2.5 mm²) ① 380 V~ 22 A Terminal block width 0.472 in (12 mm) Stripped length 0.39 in (9 - 10 mm) * PTB-certificate: Ex-88.B.3115 U	
--	---	--	--	---

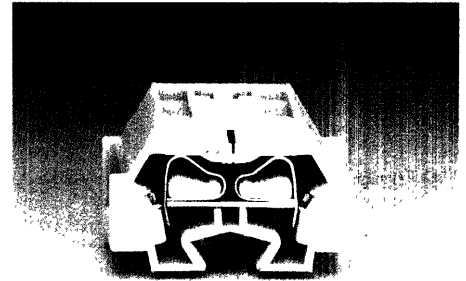
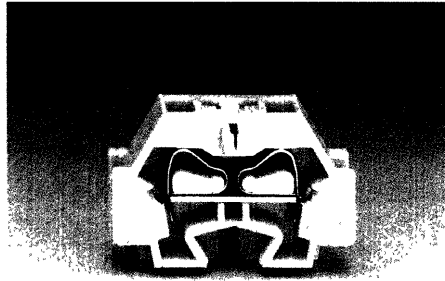







For modular terminal blocks for EEx I-applications see page 24



① The cross-sections refer to conductors without and with gastight crimped ferrules. For types of conductors and their preparation see page 33 extract from "Electrical equipment for hazardous environments".

Description	Colour	Item-No.	Pack.-unit pcs.	Colour	Item-No.	Pack.-unit pcs.
 Terminal blocks with fixing flange , for screw- or similar methods of fixing, fixing hole diameter 3.2 mm (with mounting adapter 209-123 also on rail TS 35)	light grey	262-130	100 (2 x 50)	light grey	262-230	100 (2 x 50)
 Terminal blocks with snap-in mounting foot , for plate thickness 0.6 - 1.2 mm, fixing hole diameter 3.5 mm, (also on aluminium rail 210-154 or with mount. adapter 209-120 on rail TS 35)	light grey	262-180	100 (2 x 50)	light grey	262-280	100 (2 x 50)
 End terminal block, ③ without fixing foot, for terminal block strips with snap-in mounting feet (see dimensioned drawing on page 27 and example of an assembly on page 31)	light grey	262-181	100 (2 x 50)	light grey	262-281	100 (2 x 50)

Accessories for modular terminal blocks and terminal block strips (Marking accessories see pages 28 - 29)

 End plate with fixing flange grey		262-361	50	262-361	50	
 End plate with snap-in mounting foot grey		262-371	50	262-371	50	
 Comb-type jumper bar , insulated, 2-pole $I_N = 15 A$ grey		262-402	25	262-402	25	
 Operating tool , insulated, for connecting the comb-type jumper bar		209-132	1	209-132	1	
 Aluminium carrier rail , 3"3' x 0.71 in x 0.276 in 1000 x 18 x 7 mm		210-154	1	210-154	1	
 Plastic end stop , with WSB marking facility, for aluminium rail 210-154 grey	0.236 in (6 mm) wide	209-122	25	0.236 in (6 mm) wide	209-122	25
 Mounting adapter , for terminal blocks with snap-in mounting foot, for rail TS 35		209-120	25	209-120	25	
 Mounting adapter w. screw , for terminal blocks with fixing flange, for rail TS 35		209-123	25	209-123	25	
 Mounting adapter for TS 35 , can be used as end stop grey	0.256 in (6.5 mm) wide	209-137	25	0.256 in (6.5 mm) wide	209-137	25

* For approvals with the corresponding nominal data please see pages 34 - 35.

EEx e II-terminal block strips with fixing flanges or snap-in mount. feet, series 262

WAGO Side-entry



AWG 14 (2.5 mm²) ①
380 V~
22 A
Pole width 0.276 in (7 mm)
Stripped length 0.39 in (9 - 10 mm)
*** PTB-certificate: Ex-88.B.3115 U**



2 x AWG 14 (2 x 2.5 mm²) ①
380 V~
22 A
Pole width 0.472 in (12 mm)
Stripped length 0.39 in (9 - 10 mm)
*** PTB-certificate: Ex-88.B.3115 U**



Modular terminal block strips for EEx i-applications see page 25.

① The cross-sections refer to conductors without and with gastight crimped ferrules. For types of conductors and their preparation see page 33 extract from "Electrical equipment for hazardous environments".

② For higher numbers of poles acc. to customer's specification, please see page 30

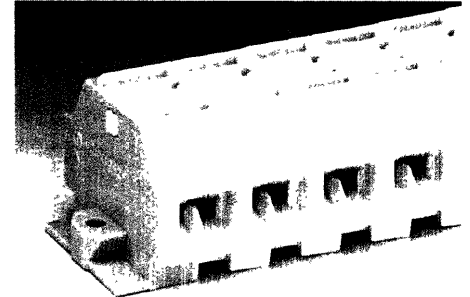
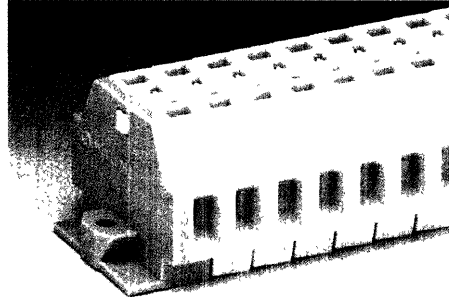

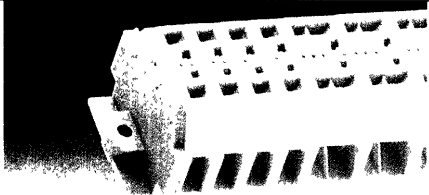
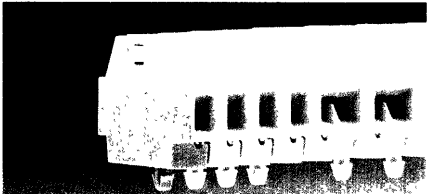
Description	No. of poles	Item-No.	Pack.-unit pcs.	No. of poles	Item-No.	Pack.-unit pcs.
 <p>Terminal block strips with fixing flanges, for screw- or similar methods of fixing, fixing hole diameter 3.2 mm (with mounting adapter 209-123 also on rail TS 35)</p>	2-cond. term. block strips with fixing flanges			4-cond. term. block strips with fixing flanges		
	light grey			light grey		
	2	262-132	100	2	262-232	100
	3	262-133	100	3	262-233	100
	4	262-134	100	4	262-234	100
	5	262-135	100	5	262-235	100
	6	262-136	50	6	262-236	50
	7	262-137	50	7	262-237	50
	8	262-138	50	8	262-238	50
	9	262-139	50	9	262-239	50
	10	262-140	25	10	262-240	25
	11	262-141	25	11	262-241	25
	12 ②	262-142	25	12 ②	262-242	25
 <p>Terminal block strips with snap-in mounting feet, for plate thickness 0.6 – 1.2 mm, fixing hole diameter 3.5 mm, (also on aluminium rail 210-154 or with mounting adapter 209-120 on rail TS 35)</p>	2-cond. term. block strips w. snap-in mount. feet			4-cond. term. block strips w. snap-in mount. feet		
	light grey			light grey		
	2	262-182	100	2	262-282	100
	3	262-183	100	3	262-283	100
	4	262-184	100	4	262-284	100
	5	262-185	100	5	262-285	100
	6	262-186	50	6	262-286	50
	7	262-187	50	7	262-287	50
	8	262-188	50	8	262-288	50
	9	262-189	50	9	262-289	50
	10	262-190	25	10	262-290	25
	11	262-191	25	11	262-291	25
	12 ②	262-192	25	12 ②	262-292	25

Dimensions for modular terminal blocks and terminal block strips (in mm)

Modular terminal blocks and terminal block strips with fixing flanges

L = No. of poles x pitch
 $L_1 = L + 8.1$ mm
 $L_2 = L + 14.5$ mm

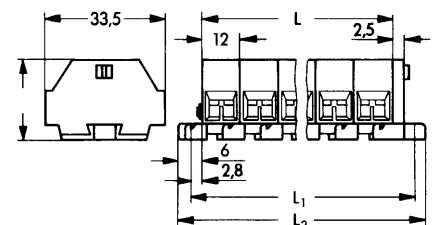
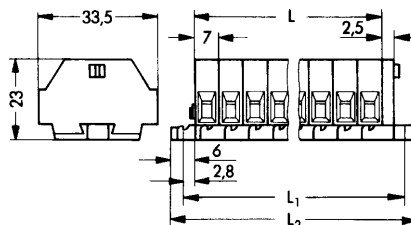

Modular terminal blocks and terminal block strips with snap-in mounting feet

③ End terminal block; see page 26 and example of an assembly on page 31

L = (No. of poles x pitch) + 4.4 mm

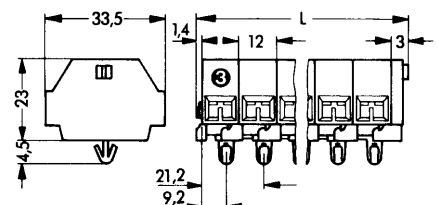
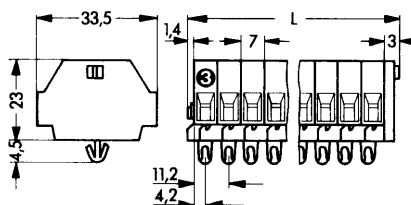

Marking accessories

for "modular terminal blocks" and "terminal block strips", series 260 to 262

WAGO self-adhesive marker strips for 2-conductor terminal block strips, 10 strips at 20 markers each per card

WAGO self-adhesive marker strips for 4-conductor terminal block strips, 10 strips at 10 markers each per card

WAGO marker bars for 2- and 4-conductor terminal block strips 20 markers per bar

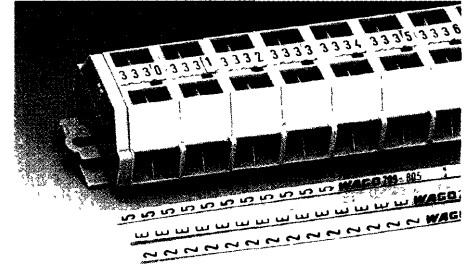
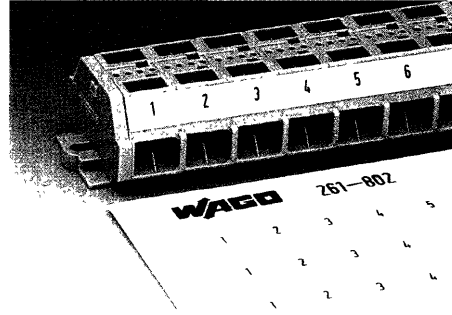
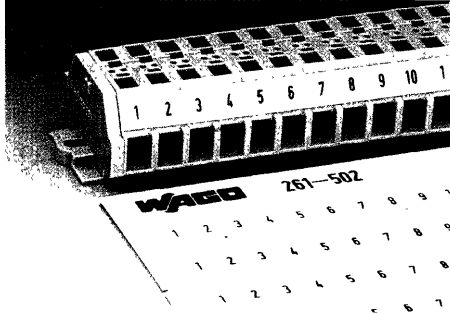

Marking	Item-No.	Item-No.	Item-No.	Marking	Item-No.	Item-No.	Item-No.	Marking	Item-No.	Pack.-unit pcs.	
suitable for 2-conductor terminal block strips of series				suitable f. 4-conductor terminal block strips of series				suitable for 2- and 4-conductor terminal block strips of series 260, 261 and 262			
	260	261	262		260	261	262	plain	209-800	10	
plain	260-501	261-501	262-501	plain	260-801	261-801	262-801	1	209-801	10	
1 - 10	260-502	261-502	262-502	1 - 10	260-802	261-802	262-802	2	209-802	10	
11 - 20	260-503	261-503	262-503	11 - 20	260-803	261-803	262-803	3	209-803	10	
21 - 30	260-504	261-504	262-504	21 - 30	260-804	261-804	262-804	4	209-804	10	
31 - 40	260-505	261-505	262-505	31 - 40	260-805	261-805	262-805	5	209-805	10	
41 - 50	260-506	261-506	262-506	41 - 50	260-806	261-806	262-806	6	209-806	10	
51 - 60	260-569	261-569		51 - 60	260-869	261-869		7	209-807	10	
61 - 70	260-570	261-570		61 - 70	260-870	261-870		8	209-808	10	
71 - 80	260-571	261-571		71 - 80	260-871	261-871		9	209-809	10	
81 - 90	260-572	261-572		81 - 90	260-872	261-872		0	209-810	10	
91 - 100	260-573	261-573		91 - 100	260-873	261-873		A	209-823	10	
1 - 50	260-566	261-566	262-566	1 - 50	260-866	261-866	262-866	B	209-824	10	
10; 20; 30; 40; 50 (2 strips per card with same numbers, red marking)	260-553	261-553	262-553	10; 20; 30; 40; 50 (2 strips per card with same numbers, red marking)	260-853	261-853	262-853	C	209-825	10	
L1	260-574	261-574	262-574	L1	260-874	261-874	262-874	D	209-826	10	
L2	260-575	261-575	262-575	L2	260-875	261-875	262-875	E	209-811	10	
L3	260-576	261-576	262-576	L3	260-876	261-876	262-876	F	209-812	10	
N	260-577	261-577	262-577	N	260-877	261-877	262-877	G	209-813	10	
PE	260-578	261-578	262-578	PE	260-878	261-878	262-878	H	209-827	10	
PEN	260-579	261-579	262-579	PEN	260-879	261-879	262-879	I	209-828	10	
Pack.-unit: 1 card				Pack.-unit: 1 card				J	209-829	10	
Ink pen, for self-marking of plain strips	210-110			Ink pen, for self-marking of plain strips	210-110			K	209-830	10	
Pack.-unit: 1 piece				Pack.-unit: 1 piece				L	209-814	10	
								M	209-831	10	
								N	209-815	10	
								O	209-832	10	
								P	209-816	10	
								Q	209-833	10	
								R	209-834	10	
								S	209-835	10	
								T	209-836	10	
								U	209-817	10	
								V	209-818	10	
								W	209-819	10	
								X	209-820	10	
								Y	209-821	10	
								Z	209-822	10	
Number of markers per terminal block											
Series	260	261	262								
2-conductor terminal block	2	2	2								
4-conductor terminal block	3	4	5								

Computerized marking accessories

WAGO adhesive marker strips for 2-conductor terminal block strips, computer marked, 20 strips per card

WAGO adhesive marker strips for 2-conductor terminal block strips, computer marked, 20 strips per card

WAGO adhesive marker strips, plain, marking by computer with WAGO software

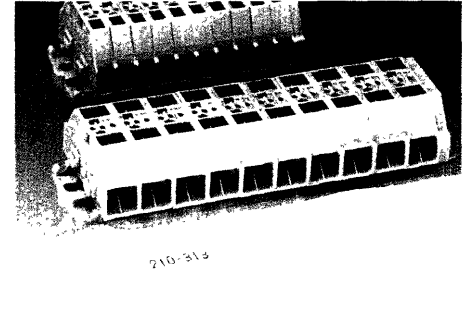
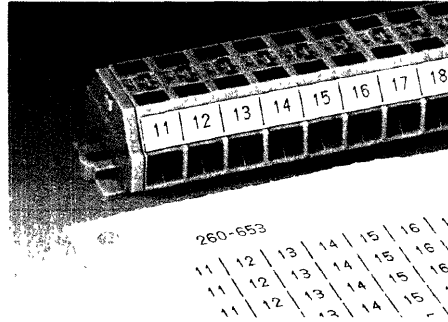
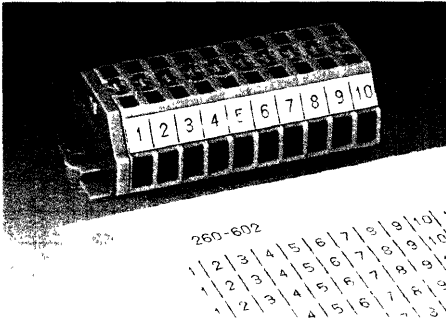

Marking	Item-no.	Pack.-unit pcs.	Marking	Item-no.	Pack.-unit pcs.	Marking	Item-No.	Pack.-unit pcs.
suitable for 2-conductor terminal block strips series 260			suitable for 4-conductor terminal block strips series 260			suitable for 2- and 4-conductor terminal block strips series 260 - 262		
1 - 10 (60x)	260-602	1 card	1 - 10 (40x)	260-652	1 card	plain	210-313	1 card
11 - 20 (60x)	260-603	1 card	11 - 20 (40x)	260-653	1 card			
21 - 30 (60x)	260-604	1 card	21 - 30 (40x)	260-654	1 card			
31 - 40 (60x)	260-605	1 card	31 - 40 (40x)	260-655	1 card			
41 - 50 (60x)	260-606	1 card	41 - 50 (40x)	260-656	1 card			
1 - 50 (10x)	260-620	1 card	1 - 50 (8x)	260-670	1 card			
series 261			series 261					
1 - 12 (40x)	261-602	1 card	1 - 16 (20x)	261-652	1 card			
13 - 24 (40x)	261-603	1 card	17 - 32 (20x)	261-653	1 card			
25 - 36 (40x)	261-604	1 card	33 - 48 (20x)	261-654	1 card			
37 - 48 (40x)	261-605	1 card	1 - 48 (6x)	261-670	1 card			
1 - 50 (10x)	261-620	1 card						
series 262			series 262					
1 - 20 (20x)	262-602	1 card	1 - 12 (20x)	262-652	1 card			
21 - 40 (20x)	262-603	1 card	13 - 24 (20x)	262-653	1 card			
1 - 50 (8x)	262-620	1 card	1 - 24 (10x)	262-670	1 card			

61	201	202	203	204	205	206	207	208	209
61	201	202	203	204	205	206	207	208	209
61	201	202	203	204	205	206	207	208	209
61	201	202	203	204	205	206	207	208	209
61	201	202	203	204	205	206	207	208	209
61	201	202	203	204	205	206	207	208	209
61	201	202	203	204	205	206	207	208	209
61	201	202	203	204	205	206	207	208	209
61	201	202	203	204	205	206	207	208	209
61	201	202	203	204	205	206	207	208	209

Further markings, also with different terminal block widths 2- and 4-conductor terminal blocks mixed, upon request.

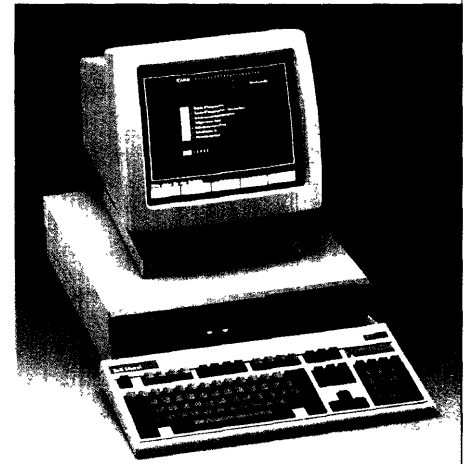

WAGO standard marking software program diskette
 English **258-112**
Standard operating, manual
 English **258-212**

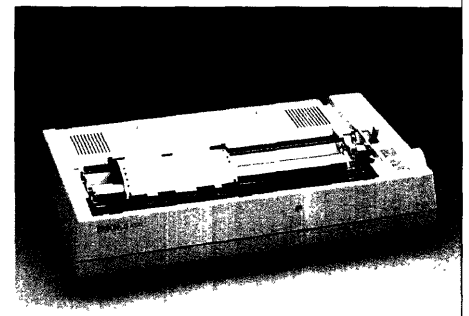

Characteristics for customer hardware:
 24 dot matrix printer

For more information concerning computer-marking see leaflet NP 13.

Order form "custom-assembled terminal block strips, series 260 to 264"

Customer's name:

Modification	5			
	4			
	3			
	2			
	1			

Page 1 of

Release note:

Drawing-no.:

WAGO item-no.:

Original	Item-no.	Date	Name

Terminal block marking with
260 ... 262 264

- self-adhesive strips (horizontally)
- direct printing (not pos. M)
- Marker bars
 - M, horizontally
 - M, vertically

Direction of reading the terminal block marking

Type

- with fixing flange
- with snap-in mounting foot
- with snap-in mounting foot and special aluminium rail

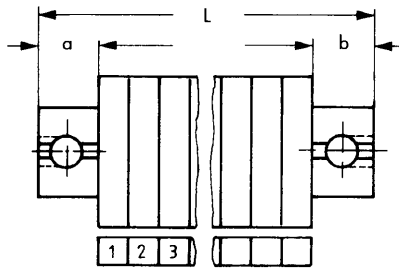

Fixing holes in special aluminium rail

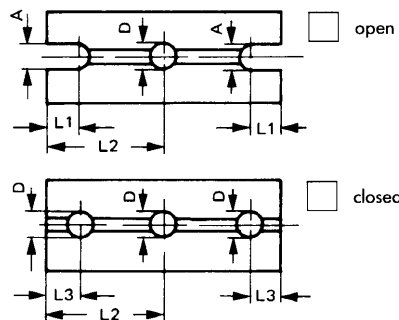

Dim. A/D	L	_____ mm
3.6	a	_____ mm
4.2	b	_____ mm
4.8	L1	_____ (max. 30) mm
5.8	L2	_____ mm
7.0	L3	_____ mm

If more than 3 mounting holes are required, please add sketch!

State of modification Sequence	Item-no.	Jumper	Terminal block marking L M R	Jumper	State of modification Sequence	Item-no.	Jumper	Terminal block marking L M R	Jumper
<input type="checkbox"/>	Here open side of terminal blocks								
1					49				
2					50				
3					51				
4					52				
5					53				
6					54				
7					55				
8					56				
9					57				
10					58				
11					59				
12					60				
13					61				
14					62				
15					63				
16					64				
17					65				
18					66				
19					67				
20					68				
21					69				
22					70				
23					71				
24					72				
25					73				
26					74				
27					75				
28					76				
29					77				
30					78				
31					79				
32					80				
33					81				
34					82				
35					83				
36					84				
37					85				
38					86				
39					87				
40					88				
41					89				
42					90				
43					91				
44					92				
45					93				
46					94				
47									
<input type="checkbox"/>	Here open side of terminal blocks								

Order form "custom-assembled terminal block strips, series 260 to 264"

Customer's name: **Musterbau KG**

Modification: 5, 4, 3, 2, 1

Page 1 of 1

Release note:

Drawing-no.:

WAGO item-no.: **261-001/038-000**

Original

Item-no. Date Name

Terminal block marking with 260...262 264

self-adhesive strips (horizontally)

direct printing (not pos. M)

Marker bars

M, horizontally

M, vertically

Direction of reading the terminal block marking

1 2 3 | L1 N PE

3 2 1 | N PE | 1 2 3

1 2 3 | L1 N PE

3 2 1 | N PE | 1 2 3

1 2 3 | L1 N PE

3 2 1 | N PE | 1 2 3

1 2 3 | L1 N PE

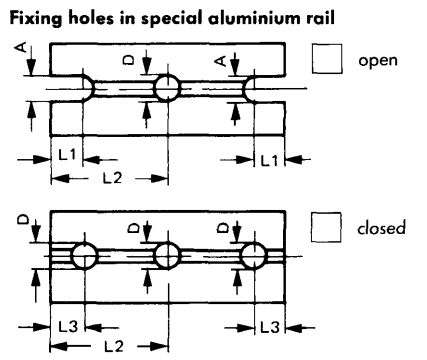
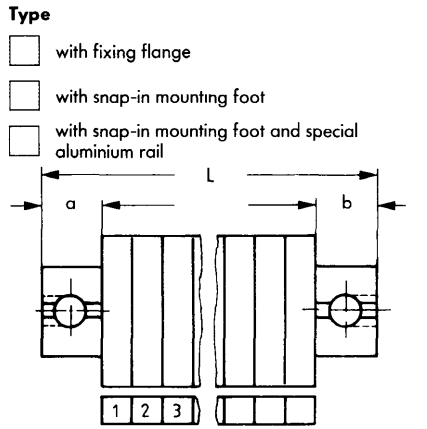

Dim. A/D

3.6	L	_____ mm
4.2	a	_____ mm b _____ mm
4.8	L1	_____ (max. 30) mm
5.8	L2	_____ mm
7.0	L3	_____ mm

If more than 3 mounting holes are required, please add sketch!

State of modification	Sequence	Item-no.	Jumper	Terminal block marking	Jumper	State of modification	Sequence	Item-no.	Jumper	Terminal block marking	Jumper	
<input type="checkbox"/>	Here open side of terminal blocks											
		Please use one position each on the form for each terminal block, end- or intermediate plate, end stop etc.!										
	1	261-313		1A	1A		49	261-371				
	2	261-313		1B	1B		50					
	3	261-313		1C	1C		51					
	4	261-313		1D	1D		52					
	5	261-313		1E	1E		53					
	6	261-313		1F	1F		54					
	7	261-313		1G	1G		55					
	8	261-313		1H	1H		56					
	9	261-316		2A	2A		57					
	10	261-316		2B	2B		58					
	11	261-316		2C	2C		59					
	12	261-316		2D	2D		60					
	13	261-316		2E	2E		61					
	14	261-316		2F	2F		62					
	15	261-316		2G	2G		63					
	16	261-316		2H	2H		64					
	17	261-313		3A	3A		65					
	18	261-313		3B	3B		66					
	19	261-313		3C	3C		67					
	20	261-313		3D	3D		68					
	21	261-313		3E	3E		69					
	22	261-313		3F	3F		70					
	23	261-313		3G	3G		71					
	24	261-313		3H	3H		72					
	25	261-316		4A	4A		73					
	26	261-316		4B	4B		74					
	27	261-316		4C	4C		75					
	28	261-316		4D	4D		76					
	29	261-316		4E	4E		77					
	30	261-316		4F	4F		78					
	31	261-316		4G	4G		79					
	32	261-316		4H	4H		80					
	33	261-313		5A	5A		81					
	34	261-313		5B	5B		82					
	35	261-313		5C	5C		83					
	36	261-313		5D	5D		84					
	37	261-313		5E	5E		85					
	38	261-313		5F	5F		86					
	39	261-313		5G	5G		87					
	40	261-313		5H	5H		88					
	41	261-316		6A	6A		89					
	42	261-316		6B	6B		90					
	43	261-316		6C	6C		91					
	44	261-316		6D	6D		92					
	45	261-316		6E	6E		93					
	46	261-316		6F	6F		94					
	47	261-316		6G	6G							
	48	261-316		6H	6H							

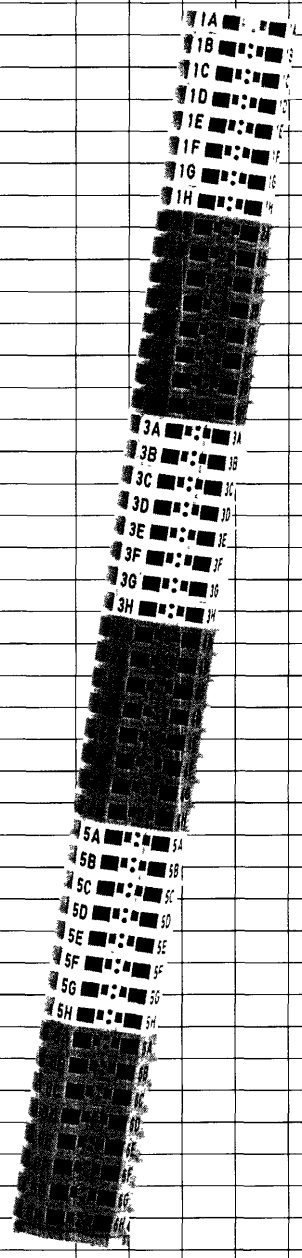

Here open side of terminal blocks

Under normal conditions of use and without special corrosive influences, direct clamping, i.e. the direct contact between conductor and current bar of the terminal block, ensures the best contact quality as all risk factors in connection with additional conductor preparation are eliminated.

If there is very little room for the introduction of the conductors into the terminal blocks or in case of cable harness preparation away from installation, the protection of the cable ends against splaying is recommended. In this case there are several possibilities, such as



the use of anti-splaying clips



tinning of the end of the conductors

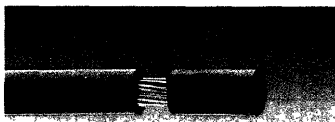

partial stripping of the insulation



the use of crimped ferrules (gastight crimped) ①



or pin terminals (gastight crimped), preferably produced from copper with tinned surface.

Connection of flexible conductors

VDE 0100, part 520/11.85 § 11.101 specifies that suitable methods have to be taken to protect flexible conductors from splaying during conductor introduction:

either by the specific design of the terminal blocks, or by preparation of the conductor ends.

VDE 0611 part 1/11.77 § 3.1.6 contains the requirement that terminal blocks up to a nominal conductor cross section of 10 mm² (AWG 8) have to allow the direct connection of flexible conductors without special preparation of their ends and without the use of crimped ferrules.

On all cage-clamp terminal blocks the specific design features ensure that the unprepared flexible conductor can be introduced easily and without the danger of splaying of individual strands: the funneled shape of the conductor entry hole in the insulation housing and the position of the mechanical clamping point directly behind the conductor entry hole.*

* a technical innovation from WAGO

When using terminal blocks in highly corrosive atmosphere, e.g. in the chemical industry and in hazardous environments, it is recommended to use either solid copper conductors or flexible copper conductors with gastight crimped ferrules or pin terminals produced from copper with tinned surface.

A crimped ferrule or pin terminal acts in the same way as a solid conductor (on the outside), with respect to the clamping unit. It should be ensured that it is properly installed, that corrosion from any aggressive atmosphere cannot pass between strands and into the clamping unit.

① *With all anti-splaying methods which increase the diameter of the conductor, it is necessary to use the terminal block one size larger for the nominal cross section.*

Connection of solid aluminium conductors

The cage-clamp* connection is also suitable for **solid** aluminium conductors up to AWG 12 (4 mm²) if these are mechanically cleaned and immediately protected against re-oxidation by an acid-free grease prior to connection.

The nominal currents must be adapted to the reduced conductivity (AWG 16/1.5 mm² = 6 A, AWG 14/2.5 mm² = 10 A, AWG 12/4 mm² = 16 A). These are temporary indications. More information concerning application are available upon request.

"One conductor per clamping unit"

A number of VDE-specifications specify that only one conductor may be connected to each clamping unit, e.g. VDE 0607/11.74 § 3.1.8, VDE 0611 part 1/11.77, § 4.1.8 and the recommendations of the association of the German automotive industry "Supply specification for the electrical

equipment of machines, mechanical installations and buildings in the automotive industry", § 6.4.3.7 and § 7.2.3.

Similar recommendations exist in other industries and other countries.

Other VDE-specifications recommend the connection of one conductor per clamping unit unless the clamping unit is specifically tested and approved for the connection of two conductors:

VDE 0659/3.80 § 25.3.1, paragraph 2

VDE 0660, part 5/11.67, § 31 dz, paragraph 2

VDE 0660, part 50, design 1/6.80

VDE 0113, design 1/2.80, § 10.1.1

VDE 0832/7.81 § 10.2.3

One conductor per cage-clamp spring is therefore recommended, to meet the safety requirements of these relevant specifications.*

This WAGO principle is the basis for a number of other technical and economical advantages:

Each conductor may be installed or removed without affecting previously installed wires.

Each conductor is clamped independently from the other.

Any combinations of conductor cross section or kind of conductor (flexible and solid) can be connected.

For commoning of clamping units WAGO offers several alternatives for rail-mounted terminal blocks:

The most frequent application is branching of one conductor to two branches.

Extract from
"Electrical equipment for
hazardous environments"***

Types of conductors and their preparation

According to the construction
specification VDE 0165/9.83
the ends of stranded and flex-
ible conductors have to be
protected against splaying,
e.g. by using pin terminals or

by the design of the terminal
blocks. Soldering of the con-
ductor ends is not permissible.
The air- and creepage distan-
ces specified in EN 50019/
VDE 0170/0171, part 6, for
the type of protection – in-
creased safety "e" – shall not
be reduced when conductors
are connected to the terminal
blocks.

When using rail-mounted ter-
minal blocks in aggressive
atmospheres, e.g. in the che-
mical industry, it is recom-

mended in the light of experi-
ence to crimp either
• tinned copper ferrules or
• tinned copper pin terminals
onto the ends of the flexible
conductors.

Approvals

Terminal blocks for which a
certificate of a European Ex-
test house for the type of pro-
tection EEx e II has been gran-
ted, consequently conforms to
the standards EN 50014 and
EN 50019, may be

used in zones 1 and 2, on con-
dition, that the terminal blocks
are contained in an enclosure
with protection degree of at
least IP 54 and for which the
EEx e certificate has also been
granted.

Terminal blocks are classed as
incomplete equipment, as they
can only be part of an instal-
lation. Therefore the Ex-test
houses authorize part certifi-
cates as a basis for the com-
plete certificate for the com-
plete installation.

Example rear of terminal block

Maximum conductor
cross section

Nominal insulating voltage

Size of clamping unit acc. to
EN 50027 for solid-, stranded and
flexible conductors.

Series No.

Manufacturer's name

Type of protection

Part certificate No.

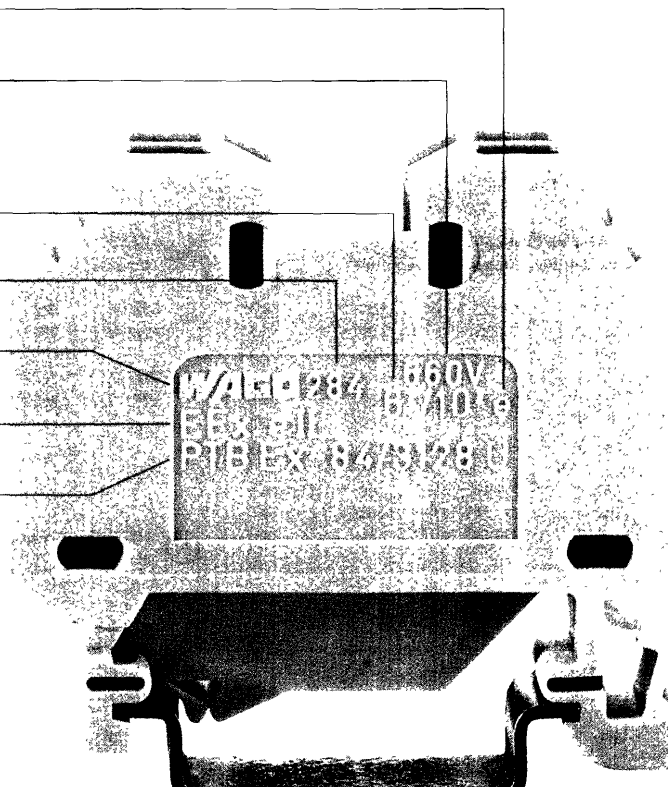

Publication of the WBK Mining
Authority from March 1989
Quotation "... terminal blocks
for which the type of protec-
tion EEx e II has been certified
will e.g. also be accepted for
use in groupe I – Electrical
equipment of the type of pro-
tection increased safety "e".

The embossed type details on
the terminal blocks show the
manufacturer's name, the
series no., the type of protec-
tion EEx e II, the approval no.,
the data of approval and the
name of the test house.

*** Extract from "WAGO Master catalogue HK 1-4, chapter 16

Approvals as per 2.11.1990

Type	Approval No.	Voltage V	Current A	Cross Section	Type	Approval No.	Voltage V	Current A	Cross Section	Type	Approval No.	Voltage V	Current A	Cross Section
UL – Underwriters Laboratories USA					SEV – Schweizerischer Elektrotechnischer Verein Switzerland					SEMKO – Svenska Elektriska Materielkontrollanstalten AB Sweden				
260-1..	E 45 172	300	10	26-14	260- ..	88.551056	500		1,5	260-...	8606200-01	500		1,5
260-2	E 45 172	300	10	26-14	261-...	88.551056	500		2,5	261-..	8606200	500		2,5
260-3	E 45 172	300	10	26-14	262-1..	90.550047	750		4	262- ..	8606200	750		4
261-1	E 45 172	300/600	15/5	24-14	262-2..	90.550047	750		4	264-...	8834014	750		2,5
261-2..	E 45 172	300/600	15/5	24-14	262-3..	90.550047	750		4	264-727	8928190			2,5
261-3..	E 45 172	300/600	15/5	24-14	264-..	88.102759	750	16	0,14 - 2,5					
262-1..	E 45 172	300/600	20/5	24-14	264-727	88.102759			2,5					
262-2..	E 45 172	300/600	20/5	24-14										
262-3..	E 45 172	300/600	20/5	24-14										
264-701	E 45 172	600	15	26-14										
264-721	E 45 172	600	15	26-14										
264-727	E 45 172	-	-	26-14										
CSA – Canadian Standards Association Canada					KEMA – N. V. tot Keuring van Elektrotechnische Materialen The Netherlands					DEMKO – Danmarks Elektriske Materielkontrol Denmark				
260-...	18 677	CSA-group C	300	26-16	260-1..	81.7249.06/07	500		1,5	260-1	72816	500		1,5
261-...	18 677	C	300	26-14	260-2..	81.7249.06/07	500		1,5	260-2	72816	500		1,5
	18 677	D	600	5	260-3..	81 7249 06/07	500		1,5	260-3..	71350	500		1,5
262-..	18 677	C	300	26-12	261-1	81 7249.06/07	500		2,5	261-1..	74829	500		2,5
	18 677	D	600	5	261-2..	81.7249.06/07	500		2,5	261-2..	74829	500		2,5
264-..	18 677	C	600	26-14	261-3	81.7249.06/07	500		2,5	261-3..	79604	500		2,5
					264-7..	88.6475 01	750		2,5	262-1..	78363	660		4
					264-727	89.8780 01			2,5	262-2 .	78363	660		4
										262-3	78363	660		4
VDE-Certificate of conformity with factory surveillance Germany					CEBEC – Comité Electrotechnique Belge Belgium					SETI – SÄHKÖTARKASTUSKESKUS ELINSPEKTIONSCENTRALEN Finland				
260-1..	207 UG, Bl. 1	500		1,5	260-1..	2822/3 C	500	20	1,5	260-30.	090877-01	500		1,5
260-2..	207 UG, Bl. 1	500		1,5	260-2	2822/3 C	500	20	1,5	260-31.	090877-02	500		1,5
260-3..	207 UG, Bl. 1	500		1,5	261-1..	2822/3 C	500	27	2,5	260-32.	090877-03	500		1,5
261-1..	208 UG, Bl. 1	500		2,5	261-2 .	2822/3 C	500	27	2,5	260-33.	090877-04	500		1,5
261-2..	208 UG, Bl. 1	500		2,5						260-34.	090877-05	500		1,5
261-3	208 UG, Bl. 1	500		2,5						260-35	090877-06	500		1,5
262-1 .	2098 UG, Bl. 1	660		4						261-30.	090876-01	500		2,5
262-2	2098 UG, Bl. 1	660		4						261-31	090876-02	500		2,5
262-3	2098 UG, Bl. 1	660		4						261-32.	090876-03	500		2,5
										261-33.	090876-04	500		2,5
										261-34.	090876-05	500		2,5
										261-35	090876-06	500		2,5
										262-30	090878-01	500		4
										262-31.	090878-02	500		4
										262-32.	090878-03	500		4
										262-33.	090878-04	500		4
										262-34.	090878-05	500		4
										262-35.	090878-06	500		4
ÖVE – Österreichischer Verband für Elektrotechnik Austria					NEMKO – Norges Elektriske Materielkontroll Norway					SABS South African Bureau of Standards South Africa				
260-1..	1193-010	500		1,5	260-1..	M 59289	500		1,5	260-1..	751/82640			1,5
260-2..	1193-010	500		1,5	260-2	M 59289	500		1,5	260-2..	751/82640			1,5
260-3	1193-010	500		1,5	260-3	M 59289	500		1,5	261-1..	751/82640			2,5
261-1	1193-010	500		2,5	261-1	M 58457	500		2,5	261-2..	751/82640			2,5
261-2	1193-010	500		2,5	261-2..	M 58457	500		2,5					
261-3..	1193-010	500		2,5	261-3..	M 58457	500		2,5					
262-1..	1193-010	750		4	262-1 .	M 60452	500		4					
262-2..	1193-010	750		4	262-2..	M 60452	500		4					
262-3..	1193-010	750		4	262-3 .	M 60452	500		4					
264-	1193-010	750		2,5										

Ex-Approvals, Shipbuilding Approvals as per 2.11.1990

Type	Approval No.	Voltage V _~	Current A	Cross Section mm ²	Type	Approval No.	Voltage V _~	Current A	Cross Section mm ²	Type	Approval No.	Voltage V _~	Current A	Cross Section mm ²
Ex-Approvals					Shipbuilding Approvals									
PTB – Physikalisch Technische Bundesanstalt Germany					GL – Germanischer Lloyd Germany									
EEx e II					GL									
262-...	Ex-88.B.3115 U	380	30	2,5	260-1..	92581 HH	250		1,5					
264-120	Ex-90.C.3101 U	250	23	1,5	260-2..	92581 HH	250		1,5					
264-220	Ex-90.C.3101 U	250	23	1,5	260-3..	92581 HH	250		1,5					
					261-1..	92582 HH	250		2,5					
					261-2..	92582 HH	250		2,5					
					261-3..	92582 HH	250		2,5					
					262-1..	92583 HH	660		4					
					262-2..	92583 HH	660		4					
					262-3..	92583 HH	660		4					
SEV – Schweizerischer Elektrotechnischer Verein Switzerland					BV – Bureau Veritas France									
EEx e II					BV									
262-1..	87.1 01459	750	27	4	260-1..	1087/2480			1,5					
262-2..	87.1 01459	750	34	4	260-2..	1087/2480			1,5					
262-3..	87.1 01459	750	27/34	4	260-3..	1087/2480			1,5					
					261-1..	1087/2480			2,5					
					261-2..	1087/2480			2,5					
					261-3..	1087/2480			2,5					
					262-1..	1087/2480			4					
					262-2..	1087/2480			4					
					262-3..	1087/2480			4					
					LR – Lloyd's Register of Shipping Great Britain									
					LR									
					260-1..	HNO 300333	500	19,5	1,5					
					260-2..	HNO 300333	500	19,5	1,5					
					261-1..	HNO 300333	500	26	2,5					
					261-2..	HNO 300333	500	26	2,5					
					262-1..	HNO 500501	750	35	4					
					262-2..	HNO 500501	750	35	4					
					USSR – Register of Shipping USSR									
					USSR									
					260-...	85.056 250								
					261-..	85 056 250								
					264-...	250-2.11-272 RT								