

### Top View of Assembly

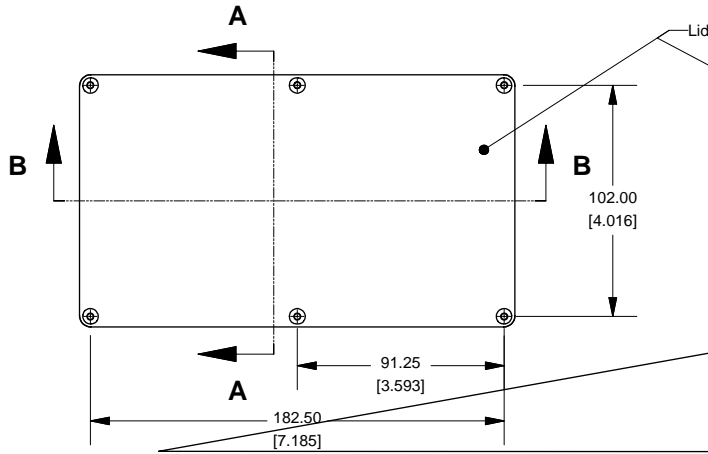

### SECTION A-A End View of Assembly

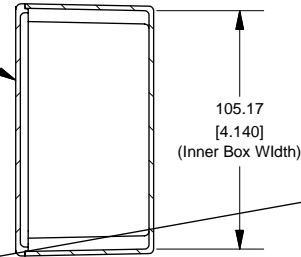

### Series 1590R1 (Basic)

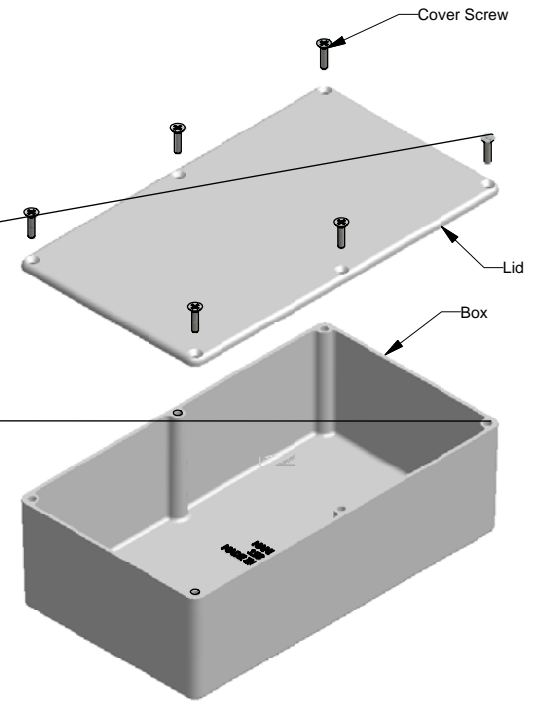

### SECTION B-B Side View of Assembly

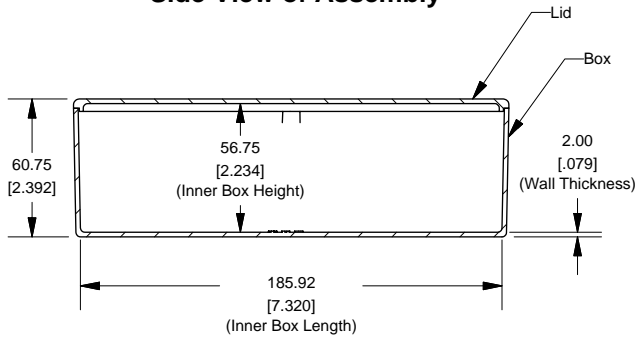

### Top View Looking Inside Box

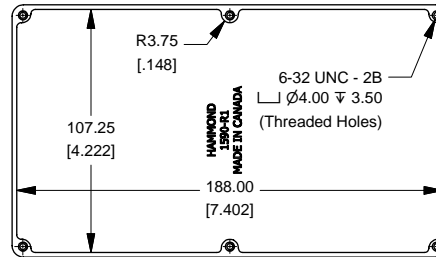

### Lid

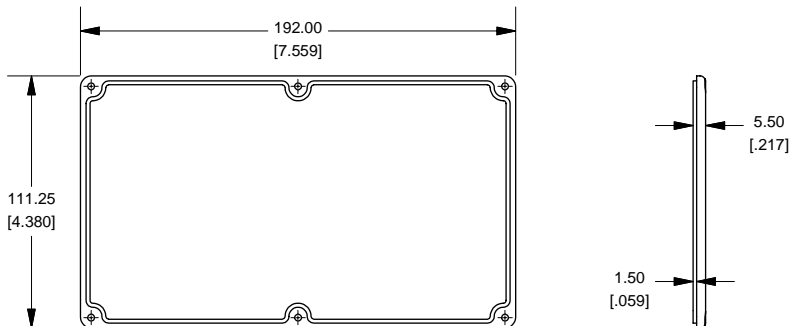

**NOTE**  
Purchased assembly includes box, lid and 4 cover screws.  
Box and lid are made from Diecast Aluminum Alloy (alloy type 360.1).

PART NUMBERS	
1590R1 Enclosure	
Unfinished	1590R1
Black Textured Powder Paint	1590R1BK
1590R1 Liquid Resistant Enclosure (Silicon Factory Installed Gasket)	
Unfinished	1590WR1
Black Textured Powder Paint	1590WR1BK
ACCESSORIES	
Unfinished	
Cover Screws (Pkg 100) [6-32 x 1/2" Nickel Plated Screws]	1590MS100
Black Textured Powder Paint	
Cover Screws (Pkg 50) [6-32 x 1/2" Stainless Steel Black Screws]	1590MS50BK

