

DC axial fan

Series 600 N 60 x 60 x 25 mm



- **General description:** DC fan with electronically commutated external rotor motor. Commutation electronics completely integrated.

- **Impeller material:** Fiberglass-reinforced PA plastic

- **Housing material:** Fiberglass-reinforced PBTP plastic

Nominal data		Voltage	Voltage range VDC	Air flow	Speed	Power consumption	Sound level	Sound pressure level	Ambient temperature	L10 service life at 40 °C	L10 service life at max. temp.	Weight
Type	Motor	VDC	VDC	m³/h	1/min	W	Bel	dB(A)	°C	h	h	kg
612 NGLE	--	12	8 - 15	21	2500	0.6	3.6	16	-20 .. 85	80000	27500	0.085

Subject to modification

Characteristic: Pressure over air flow

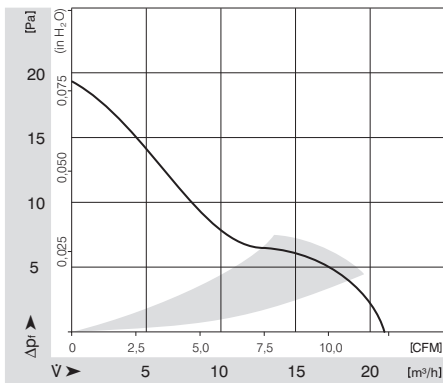

DC axial fan

Series 600 N 60 x 60 x 25 mm

Specific drawing

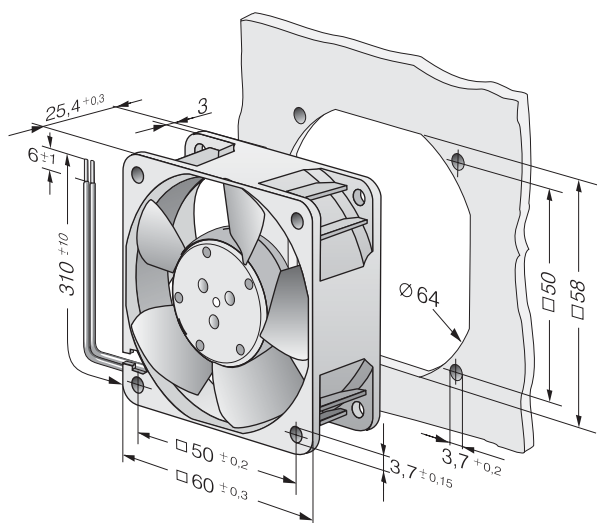

Technical description

- **General description:** DC fan with electronically commutated external rotor motor. Commutation electronics completely integrated.
- **Housing material:** Fiberglass-reinforced PBTP plastic
- **Direction of rotation:** Right, looking at rotor
- **Electrical connection:** 2 single strands AWG 22, TR 64
- **Blocking protection:** With electronic blocking and overload protection
- **Impeller material:** Fiberglass-reinforced PA plastic
- **Bearings:** Sintec sleeve bearing system
- **Direction of flow:** Air exhaust over bars
- **Motor protection:** With electronic reverse polarity protection. The fan runs only if the polarity is correct.
- **Approvals:** VDE, CSA, UL, CE

Contact

ebm-papst St. Georgen GmbH & Co. KG

Hermann-Papst-Straße 1
D-78112 St. Georgen
Phone +49 (0) 7724 / 81-0
Fax +49 (0) 7724 / 81-1309
info2@de.ebmpapst.com
www.ebmpapst.com

Guard grille

Order No.

LZ28-1

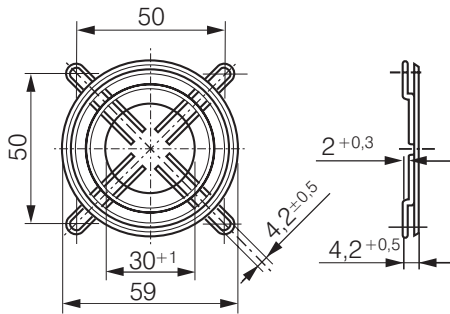

Technical description

- **General description:** Guard grille in accordance with EN 294

- **Material:** Rust-protected steel wire

Contact

ebm-papst St. Georgen GmbH & Co. KG

Hermann-Papst-Straße 1

D-78112 St. Georgen

Phone +49 (0) 7724 / 81-0

Fax +49 (0) 7724 / 81-1309

info2@de.ebmpapst.com

www.ebmpapst.com