

10 mm Square Center Space Long Travel SMD Light Touch Switches

Type: **EVPAD**

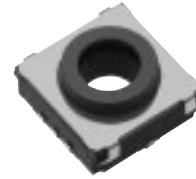

■ Features

- The open center space allows for flexibility in choosing a LED
Up to a 4.2-mm diameter chip LED can be mounted.
- Provides an excellent operational feel.
 - Crisp tactile feedback
 - Long stroke (1 mm)
- Supports auto reflow soldering.

■ Recommended Applications

- Operating switches for car electronic equipment (car audio systems, car air conditioners, etc.)

■ Explanation of Part Numbers

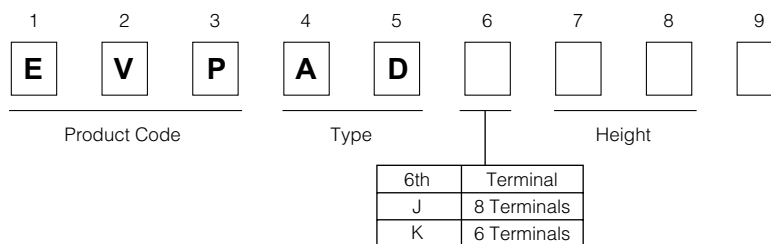

■ Specifications

Type		Snap action/Push-on type SPST
Electrical	Rating	10 μ A 2 Vdc to 50 mA 12 Vdc (Resistive load)
	Contact Resistance	100 m Ω max.
	Insulation Resistance	100 M Ω min. (at 100 Vdc)
	Dielectric Withstanding Voltage	250 Vac for 1 minute
	Bouncing	10 ms max. (ON, OFF)
Mechanical	Operating Force	4.0 N \pm 0.8 N
	Travel	1.0 mm \pm 0.15 mm
Endurance	Operating Life	100000 cycles min.
Operating Temperature		-40 °C to +85 °C
Storage Temperature		-40 °C to +85 °C (Bulk) -20 °C to +60 °C (Taping)
Minimum Quantity/Packing Unit		1000 pcs. Embossed Taping (Reel Pack)
Quantity/Carton		5000 pcs.

NEW

■ Dimensions in mm (not to scale)

No. 1

EVPADJ04K

(Embossed Taping)

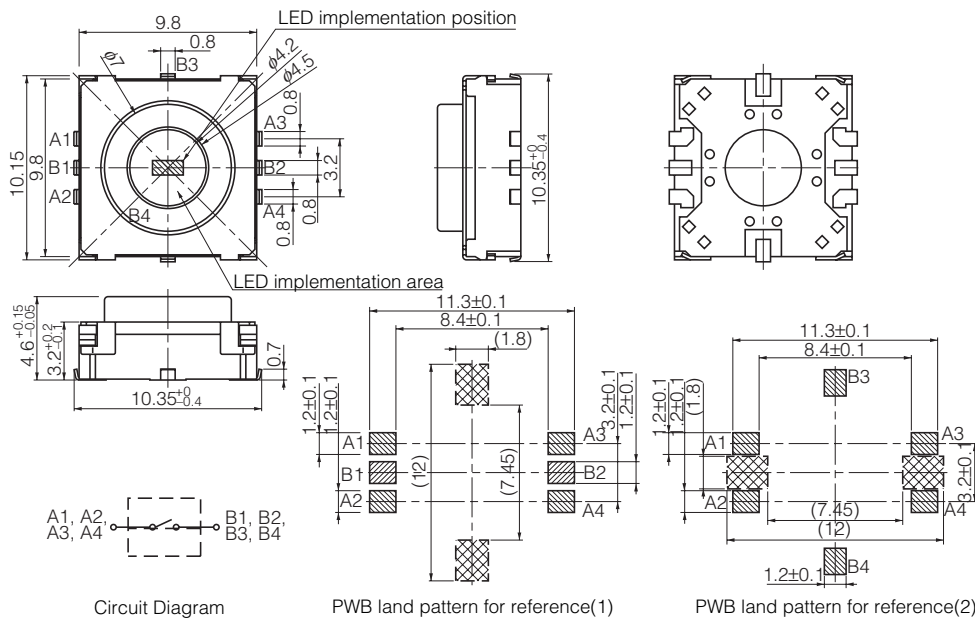

(Precautions for pattern design)

* Note that the terminals are exposed at the sections shaded with " "

* Establish electrical connection at A1, A2, A3, and A4 to improve the contact performance.

No. 2

EVPADK04K

(Embossed Taping)

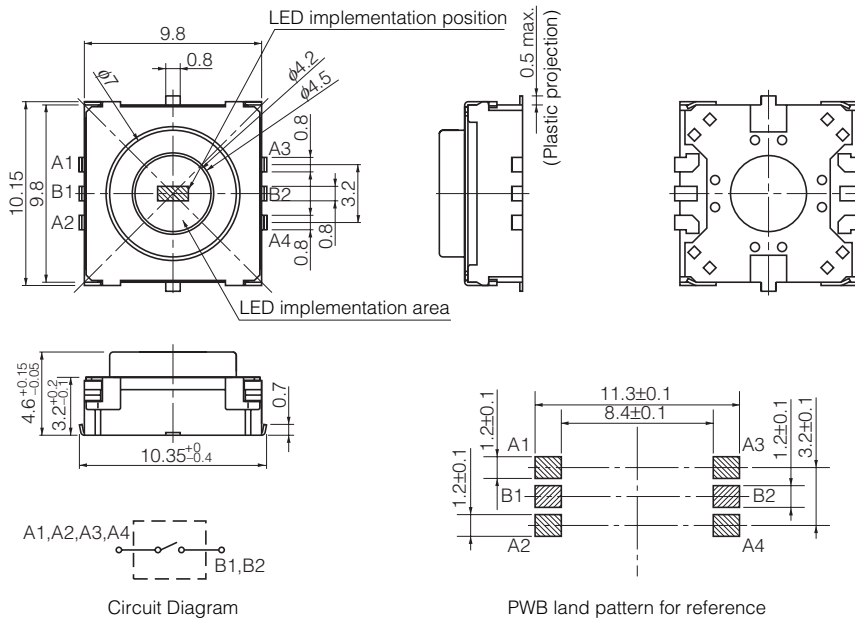

(Precautions for pattern design)

* Note that the terminals are exposed at the sections shaded with " "

* Establish electrical connection at A1, A2, A3, and A4 to improve the contact performance.

Recommended Reflow Soldering Conditions

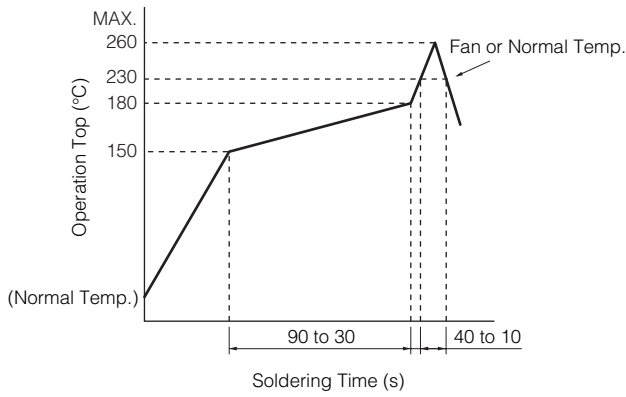

Embossed Carrier Taping

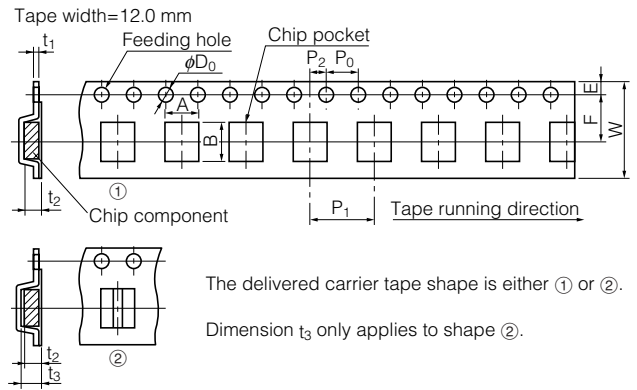

Unit: mm

Part No.	Height	A	B	W	F	E	P1	P2	P0	D0 Dia	t1	t2	t3
EVPAD	4.6	10.7±0.2	10.7±0.2	16.0±0.3	7.5±0.1	1.75±0.10	12.0±0.1	2.0±0.1	4.0±0.1	1.5 ^{+0.1} ₀	0.40±0.05	4.8±0.2	5.8±2.0

Standard Reel Dimensions in mm (not to scale)

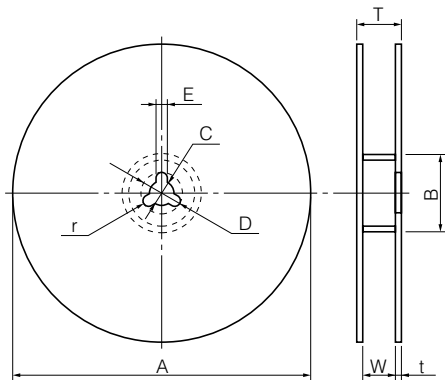

Item	A	B	C	D	E
Rate (mm)	φ380.0±2.0	φ80.0±1.0	φ13.0±0.5	φ21.0±1.0	2.0±0.5

Item	W	T	t	r
Rate (mm)	17.5±0.5	21.5±1.0	—	—