

Features

- 1.3V Maximum Dropout at Full Load Current
- Fast Transient Response
- Output Current Limiting
- Built-in Thermal Shutdown
- Good Noise Rejection
- 3-Terminal Adjustable or Fixed 1.5V / 1.8V / 2.5V / 2.8V / 3.0V / 3.3V / 3.5V / 5.0V
- Lead Free Package: SOT89-3L
- SOT89-3L: Available in "Green" Molding Compound (No Br, Sb)
- Lead Free Finish/ RoHS Compliant (Note 1)

General Description



AP1115 is a low dropout positive adjustable or fixed mode regulator with 0.6A output current capability. The product is specifically designed to provide well-regulated bus supply for low voltage IC applications such as high-speed bus termination and low current 3.3V logic supply. AP1115 is also well suited for other applications such as VGA cards. AP1115 is guaranteed to have <1.3V dropout at full load current making it ideal to provide well regulated outputs of 1.25V to 5V with up to 18V input supply.

Applications

- PC Peripheral
- Communication

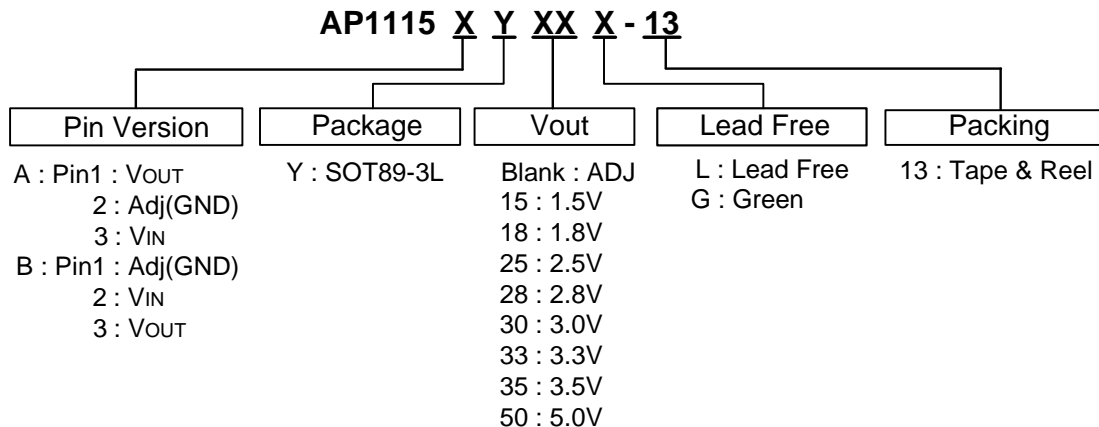
Ordering Information



Device	Package Code	Packaging (Note 2)	13" Tape and Reel	
			Quantity	Part Number Suffix
 AP1115XYXX-L-13	Y	SOT89-3L	2500/Tape & Reel	-13
 AP1115XYXX-G-13	Y	SOT89-3L	2500/Tape & Reel	-13

Notes: 1. EU Directive 2002/95/EC (RoHS). All applicable RoHS exemptions applied. Please visit our website at http://www.diodes.com/products/lead_free.html.
 2. Pad layout as shown on Diodes Inc. suggested pad layout document AP02001, which can be found on our website at <http://www.diodes.com/datasheets/ap02001.pdf>.

Pin Assignments

(1) AP1115A

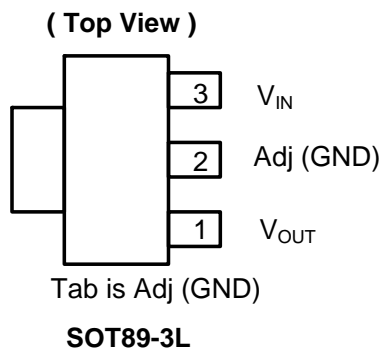

(2) AP1115B

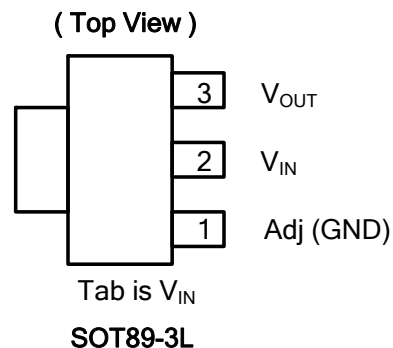

Pin Descriptions

Pin Name	I/O	Description
Adj _i (GND)	I	A resistor divider from this pin to the V_{OUT} pin and ground sets the output voltage (Ground only for Fixed-Mode).
V_{OUT}	O	The output of the regulator. A minimum of 10uF capacitor ($0.15\Omega \leq ESR \leq 20\Omega$) must be connected from this pin to ground to insure stability.
V_{IN}	I	The input pin of regulator. Typically a large storage capacitor ($0.15\Omega \leq ESR \leq 20\Omega$) is connected from this pin to ground to insure that the input voltage does not sag below the minimum dropout voltage during the load transient response. This pin must always be 1.3V higher than V_{OUT} in order for the device to regulate properly.

Typical Circuit

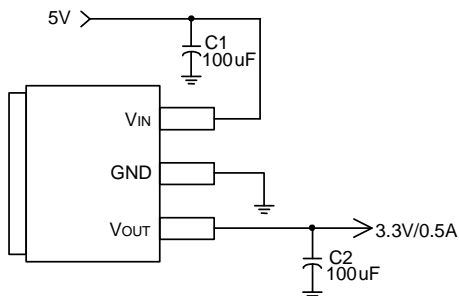

AP1115 A (5V/3.3V Fixed Output)

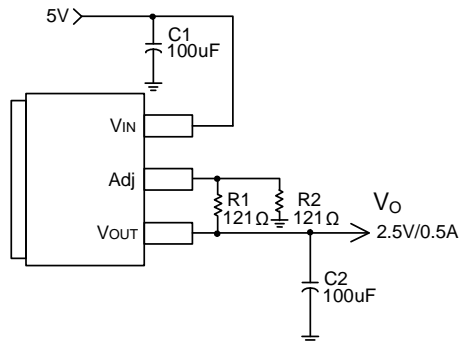

AP1115 A (5V/2.5V Adj Output)

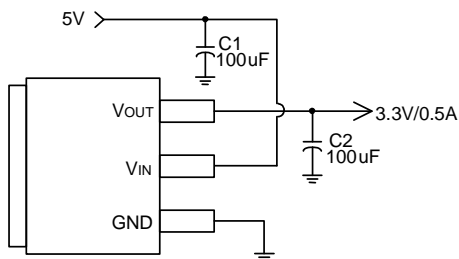

AP1115 B (5V/3.3V Fixed Output)

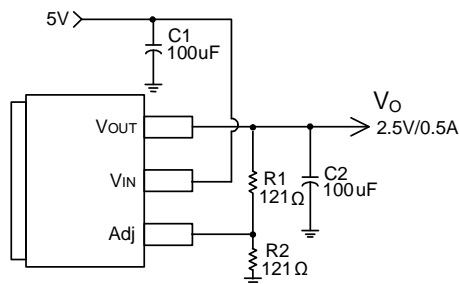

AP1115 B (5V/2.5V Adj Output)

Note: $V_o = V_{REF} \times (1 + \frac{R_2}{R_1})$

Absolute Maximum Ratings

Symbol	Parameter	Rating	Unit
V_{IN}	DC Supply Voltage	-0.3 to 18 V	V
P_D	Power Dissipation	Internally Limited	mW
T_{ST}	Storage Temperature	-65 to +150	°C
T_{MJ}	Maximum Junction Temperature	150	°C

Recommended Operating Conditions

Symbol	Parameter	Min	Max	Unit
T_{OP}	Operating Junction Temperature Range	0	125	°C

Electrical Characteristics (Under Operating Conditions)

Parameter	Conditions		Min	Typ.	Max	Unit
Reference Voltage	AP1115-ADJ	$T_A = 25^\circ\text{C}$, $(V_{IN} - V_{OUT}) = 1.5\text{V}$ $I_O = 10\text{mA}$	1.225	1.250	1.275	V
Output Voltage	AP1115-1.5	$I_{OUT} = 10\text{mA}$, $T_A = 25^\circ\text{C}$, $3\text{V} \leq V_{IN} \leq 12\text{V}$	1.470	1.500	1.530	V
	AP1115-1.8	$I_{OUT} = 10\text{mA}$, $T_A = 25^\circ\text{C}$, $3.3\text{V} \leq V_{IN} \leq 12\text{V}$	1.764	1.800	1.836	V
	AP1115-2.5	$I_{OUT} = 10\text{mA}$, $T_A = 25^\circ\text{C}$, $4\text{V} \leq V_{IN} \leq 12\text{V}$	2.450	2.500	2.550	V
	AP1115-2.8	$I_{OUT} = 10\text{mA}$, $T_A = 25^\circ\text{C}$, $4.3\text{V} \leq V_{IN} \leq 12\text{V}$	2.744	2.800	2.856	V
	AP1115-3.0	$I_{OUT} = 10\text{mA}$, $T_A = 25^\circ\text{C}$, $4.5\text{V} \leq V_{IN} \leq 12\text{V}$	2.940	3.000	3.060	V
	AP1115-3.3	$I_{OUT} = 10\text{mA}$, $T_A = 25^\circ\text{C}$, $4.8\text{V} \leq V_{IN} \leq 12\text{V}$	3.235	3.300	3.365	V
	AP1115-3.5	$I_{OUT} = 10\text{mA}$, $T_A = 25^\circ\text{C}$, $5\text{V} \leq V_{IN} \leq 12\text{V}$	3.430	3.500	3.570	V
	AP1115-5.0	$I_{OUT} = 10\text{mA}$, $T_A = 25^\circ\text{C}$, $6.5\text{V} \leq V_{IN} \leq 12\text{V}$	4.900	5.000	5.100	V
Line Regulation	AP1115-XXX	$I_O = 10\text{mA}$, $V_{OUT} + 1.5\text{V} < V_{IN} < 15\text{V}$, $T_A = 25^\circ\text{C}$	-	-	0.2	%
Load Regulation	AP1115-ADJ	$V_{IN} = 3.3\text{V}$, $V_{adj} = 0$, $0\text{mA} < I_O < 0.6\text{A}$, $T_A = 25^\circ\text{C}$ (Note 3, 4)	-	-	1	%
	AP1115-1.5	$V_{IN} = 3\text{V}$, $0\text{mA} < I_O < 0.6\text{A}$, $T_A = 25^\circ\text{C}$ (Note 3, 4)	-	12	15	mV
	AP1115-1.8	$V_{IN} = 3.3\text{V}$, $0\text{mA} < I_O < 0.6\text{A}$, $T_A = 25^\circ\text{C}$ (Note 3, 4)	-	15	18	mV
	AP1115-2.5	$V_{IN} = 4\text{V}$, $0\text{mA} < I_O < 0.6\text{A}$, $T_A = 25^\circ\text{C}$ (Note 3, 4)	-	20	25	mV
	AP1115-2.8	$V_{IN} = 4.3\text{V}$, $0\text{mA} < I_O < 0.6\text{A}$, $T_A = 25^\circ\text{C}$ (Note 3, 4)	-	22	28	mV
	AP1115-3.0	$V_{IN} = 5\text{V}$, $0 \leq I_{OUT} \leq 0.6\text{A}$, $T_A = 25^\circ\text{C}$ (Note 3, 4)	-	23	30	mV
	AP1115-3.3	$V_{IN} = 5\text{V}$, $0 \leq I_{OUT} \leq 0.6\text{A}$, $T_A = 25^\circ\text{C}$ (Note 3, 4)	-	26	33	mV
	AP1115-3.5	$V_{IN} = 5\text{V}$, $0 \leq I_{OUT} \leq 0.6\text{A}$, $T_A = 25^\circ\text{C}$ (Note 3, 4)	-	28	35	mV
	AP1115-5.0	$V_{IN} = 8\text{V}$, $0 \leq I_{OUT} \leq 0.6\text{A}$, $T_A = 25^\circ\text{C}$ (Note 3, 4)	-	40	50	mV
Dropout Voltage ($V_{IN} - V_{OUT}$)	AP1115-ADJ/1.5/1.8 2.5/2.8/3.0/3.3/3.5/5.0	$I_{OUT} = 0.6\text{A}$, $\Delta V_{OUT} = 1\%V_{OUT}$	-	1.1	1.3	V
Current Limit	AP1115-ADJ/1.5/1.8 2.5/2.8/3.0/3.3/3.5/5.0	$(V_{IN} - V_{OUT}) = 5\text{V}$	0.7	-	-	A
Minimum Load Current (Note 5)	AP1115-XXX	$0^\circ\text{C} \leq T_J \leq 125^\circ\text{C}$	-	5	10	mA
Thermal Regulation	$T_A = 25^\circ\text{C}$, 30ms pulse		-	0.008	0.04	%/W

- Notes:
- See thermal regulation specifications for changes in output voltage due to heating effects. Line and load regulation are measured at a constant junction temperature by low duty cycle pulse testing. Load regulation is measured at the output lead = 1/18" from the package.
 - Line and load regulation are guaranteed up to the maximum power dissipation of 5W. Power dissipation is determined by the input/output differential and the output current. Guaranteed maximum power dissipation will not be available over the full input/output range.
 - Quiescent current is defined as the minimum output current required to maintain regulation. At 12V input/output differential the device is guaranteed to regulate if the output current is greater than 10mA.

Electrical Characteristics (Continued) (Under Operating Conditions)

Parameter	Conditions	Min	Typ.	Max	Unit
Ripple Rejection	$f = 120\text{Hz}, C_{\text{OUT}} = 25\mu\text{F Tantalum}, I_{\text{OUT}} = 0.6\text{A}$				
	AP1115-XXX $V_{\text{IN}} = V_{\text{OUT}} + 3\text{V}$	-	60	70	dB
Temperature Stability	$I_{\text{O}} = 10\text{mA}$	-	0.6	-	%
θ_{JA}	Thermal Resistance Junction-to-Ambient (No heat sink; No air flow) (Note 6)	-	164	-	$^{\circ}\text{C/W}$
θ_{JC}	Thermal Resistance Junction-to-Case Control Circuitry/Power Transistor (Note 6)	-	35	-	$^{\circ}\text{C/W}$

Notes: 6. Test conditions for SOT89-3L: Device mounted on FR-4 substrate, 2oz copper, with minimum recommended pad layout.

Typical Performance Characteristics

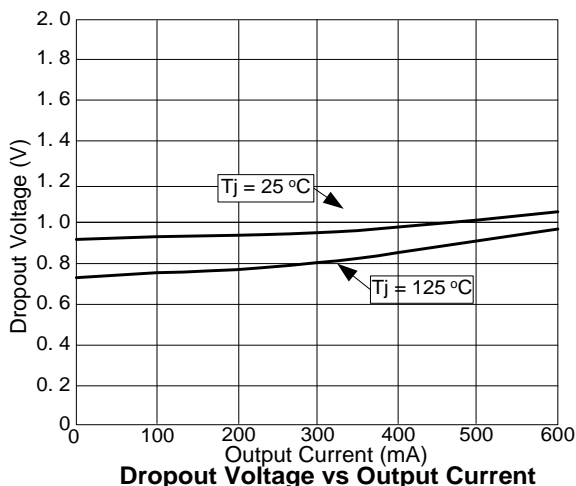

Dropout Voltage vs Output Current

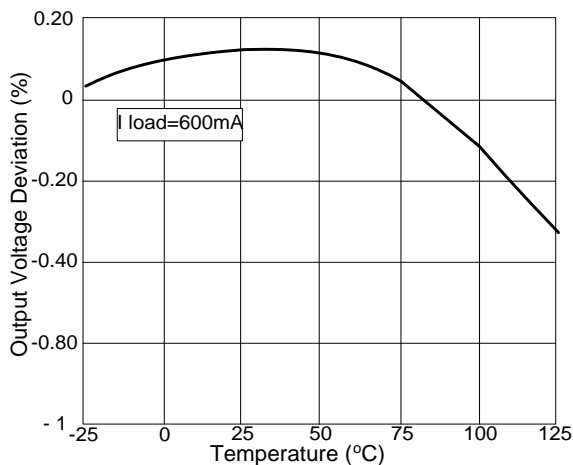

Load Regulation vs Temperature

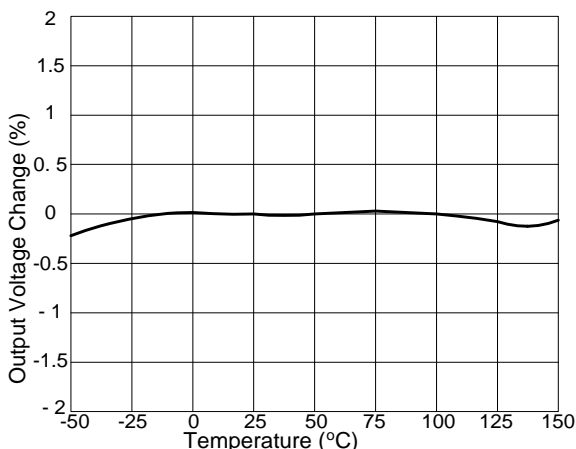

Percent Change in Output Voltage vs Temperature

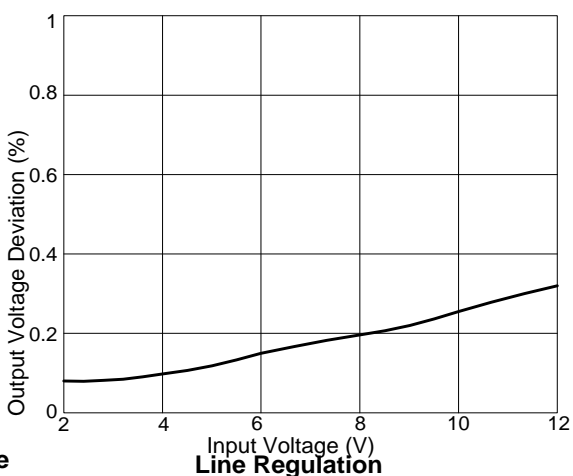

Line Regulation

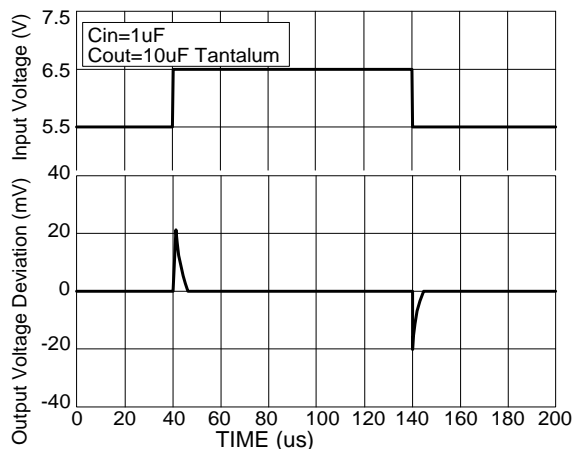

Line Transient Response

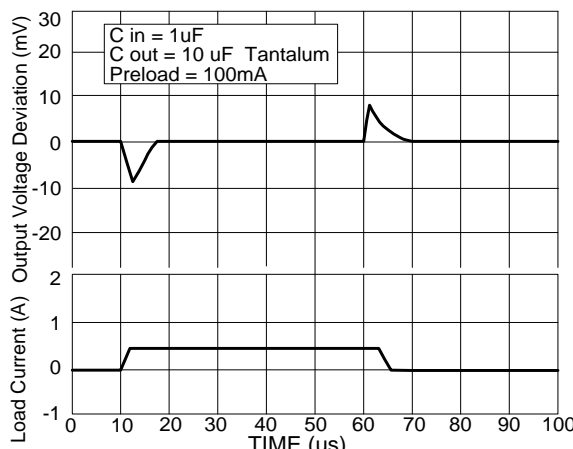

Load Transient Response

Marking Information

(Top View)

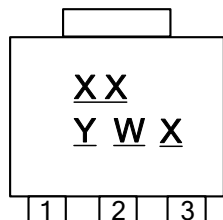

XX : Identification code
Y : Year : 0~9
W : Week : A~Z : 1~26 week;
 a~z : 27~52 week;
 z represents 52 and 53 week
X : Internal code
 a~z : Lead Free
 A~Z : Green

Output version	Identification Code	
	AP1115A	AP1115B
ADJ	JO	JU
1.5V	JP	JV
1.8V	JQ	JW
2.5V	JR	JX
2.8V	JC	JD
3.0V	JM	JN
3.3V	JS	JY
3.5V	JK	JL
5.0V	JT	JZ

Package Information (All Dimensions in mm)

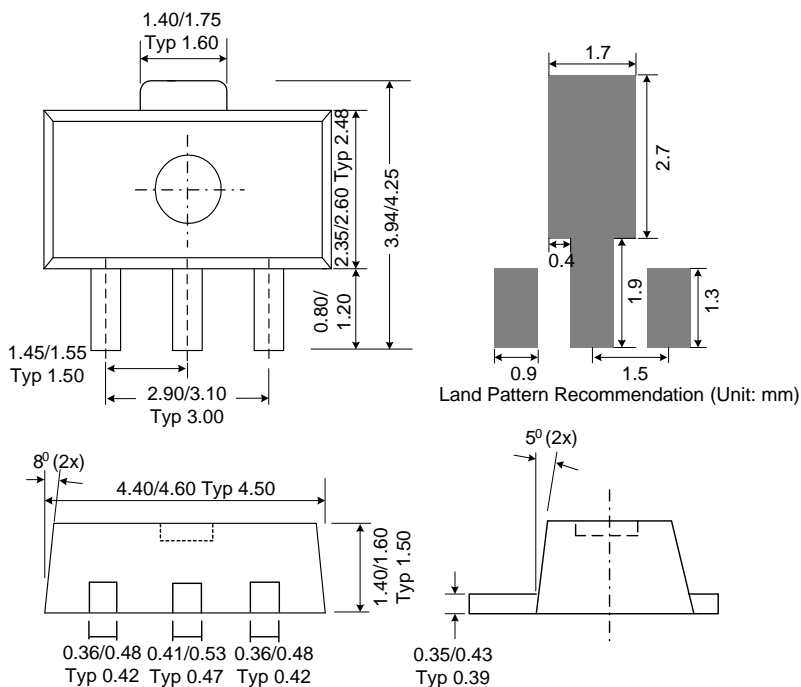

IMPORTANT NOTICE

Diodes Incorporated and its subsidiaries reserve the right to make modifications, enhancements, improvements, corrections or other changes without further notice to any product herein. Diodes Incorporated does not assume any liability arising out of the application or use of any product described herein; neither does it convey any license under its patent rights, nor the rights of others. The user of products in such applications shall assume all risks of such use and will agree to hold Diodes Incorporated and all the companies whose products are represented on our website, harmless against all damages.

LIFE SUPPORT

Diodes Incorporated products are not authorized for use as critical components in life support devices or systems without the expressed written approval of the President of Diodes Incorporated.