

DC Cooling Fan DC 6020



SIZE :

60x60x20mm (2.36"x2.36"x0.79")

CONSTRUCTION :

Glass fiber reinforced plastic:

Impeller and housing PBT are UL 94V-0 rating

OPERATING TEMPERATURE :

Ball bearing - 30°C to +75°C

Sleeve bearing - 10°C to +70°C

INSULATION RESISTANCE :

10meg Ohm min. at 500 VDC

(between frame and terminal)

DIELECTRIC STRENGTH :

5mA max. at 500 VAC 60Hz one minute

(between frame and terminal)

FUNCTION :

frequency generator signal option

WEIGHT :

55 grams

Specifications

Specifications are subject to change without notice

MODEL NO.	BEARING	RATED VOLTAGE	OPERATING VOLTAGE RANGE	RATED CURRENT	RATED INPUT POWER	SPEED R.P.M.	MAX. AIR FLOW		MAX. AIR PRESSURE		NOISE dB-A
		VDC	V	A	W		m ³ /min	CFM	mmH ₂ O	IN H ₂ O	
BP602012L	Ball	12	10.2-13.8	0.09	1.08	3000	0.39	13.8	2.29	0.09	23.39
SP602012L	Sleeve										
BS602012L	Ball & Sleeve										
BP602012M	Ball	12	10.2-13.8	0.12	1.44	3600	0.49	17.3	3.44	0.14	26.16
SP602012M	Sleeve										
BS602012M	Ball & Sleeve										
BP602012H	Ball	12	10.2-13.8	0.15	1.80	4200	0.57	20.3	4.57	0.18	30.43
SP602012H	Sleeve										
BS602012H	Ball & Sleeve										
BP602012HH	Ball	12	10.2-13.8	0.18	2.16	4800	0.66	23.4	5.73	0.23	35.53
SP602012HH	Sleeve										
BS602012HH	Ball & Sleeve										

Dimensions (mm)

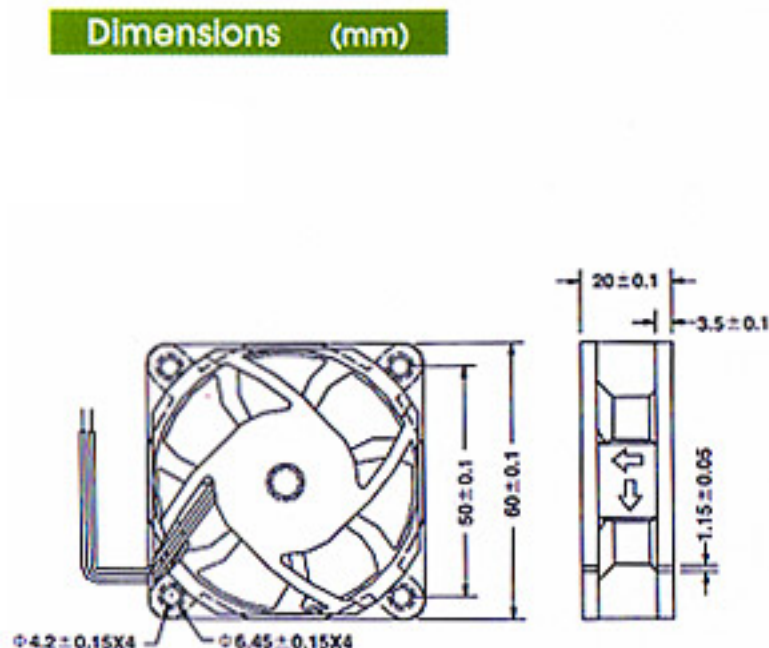

Performance Curve

