

DC 12025

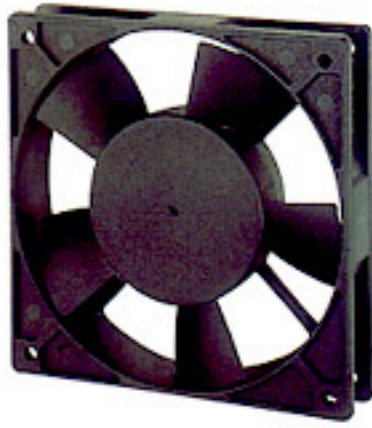

SIZE :

120x120x25mm (4.72"x4.72"x0.98")

CONSTRUCTION :

Glass fiber reinforced plastic:

Impeller and housing PBT are UL 94V-0 rating

OPERATING TEMPERATURE :

Ball bearing - 30°C to +75°C

Sleeve bearing - 10°C to +70°C

INSULATION RESISTANCE :

10meg Ohm min. at 500 VDC

(between frame and terminal)

DIELECTRIC STRENGTH :

5mA max. at 500 VAC 60Hz one minute

(between frame and terminal)

FUNCTION :

frequency generator or rotation detection signal option

WEIGHT :

150 grams



Specifications

Specifications are subject to change without notice

MODEL NO.	BEARING	RATED VOLTAGE	OPERATING VOLTAGE RANGE	RATED CURRENT	RATED INPUT POWER	SPEED R.P.M.	MAX. AIR FLOW		MAX. AIR PRESSURE		NOISE dB-A
		VDC	V	A	W		m ³ /min	CFM	mmH ₂ O	IN H ₂ O	
BP1202512L	Ball	12	10.2-13.8	0.14	1.68	2000	1.738	61.40	2.90	0.114	38
SP1202512L	Sleeve										
BP1202524L	Ball	24	20.4-27.6	0.10	2.40	2000	1.738	61.40	2.90	0.114	38
SP1202524L	Sleeve										
BP1202512M	Ball	12	10.2-13.8	0.25	3.00	2500	2.108	74.50	3.80	0.150	43.84
SP1202512M	Sleeve										
BP1202524M	Ball	24	20.4-27.6	0.18	4.32	2500	2.108	74.50	3.80	0.150	43.84
SP1202524M	Sleeve										
BP1202512H	Ball	12	10.2-13.8	0.38	4.56	3000	2.499	88.30	4.80	0.189	48.32
SP1202512H	Sleeve										
BP1202524H	Ball	24	20.4-27.6	0.24	5.76	3000	2.499	88.30	4.80	0.189	48.32
SP1202524H	Sleeve										

Dimensions (mm)

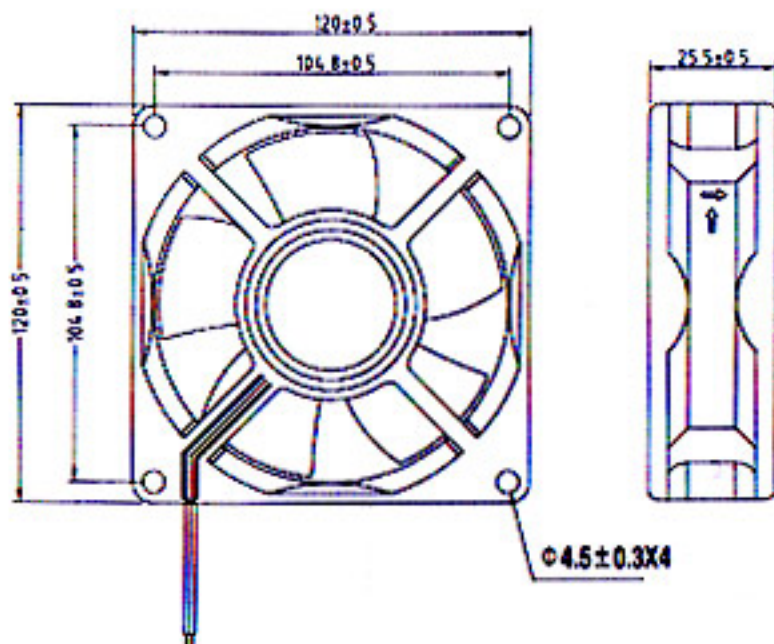

Performance Curve

