

# DC 6025-03



## SIZE :

60x60x25mm (2.36"x2.36"x0.98")

## CONSTRUCTION :

Glass fiber reinforced plastic:

Impeller and housing PBT are UL 94V-0 rating

## OPERATING TEMPERATURE :

Ball bearing - 30°C to + 75°C

Sleeve bearing - 10°C to + 70°C

## INSULATION RESISTANCE :

10meg Ohm min. at 500 VDC

(between frame and terminal)

## DIELECTRIC STRENGTH :

5mA max. at 500 VAC 60Hz one minute

(between frame and terminal)

## FUNCTION :

frequency generator or rotation detection signal option

## WEIGHT :

75 grams



## Specifications

Specifications are subject to change without notice

MODEL NO.	BEARING	RATED VOLTAGE	OPERATING VOLTAGE RANGE	RATED CURRENT	RATED INPUT POWER	SPEED R.P.M.	MAX. AIR FLOW		MAX. AIR PRESSURE		NOISE dB-A
		VDC	V	A	W		m <sup>3</sup> /min	CFM	mmH <sub>2</sub> O	IN H <sub>2</sub> O	
BP602512L-03	Ball	12	10.2-13.8	0.09	1.08	2600	0.36	12.8	1.8	0.074	23
SP602512L-03	Sleeve										
BS602512L-03	Ball & Sleeve										
BP602512M-03	Ball	12	10.2-13.8	0.11	1.32	3200	0.47	16.7	3.1	0.122	25
SP602512M-03	Sleeve										
BS602512M-03	Ball & Sleeve										
BP602512H-03	Ball	12	10.2-13.8	0.13	1.56	3800	0.55	19.5	4.12	0.162	29.6
SP602512H-03	Sleeve										
BS602512H-03	Ball & Sleeve										
BP602524L-03	Ball	24	20.4-27.6	0.08	1.92	2600	0.36	12.8	1.8	0.074	23
SP602524L-03	Sleeve										
BS602524L-03	Ball & Sleeve										
BP602524M-03	Ball	24	20.4-27.6	0.10	2.40	3200	0.47	16.7	3.1	0.122	25
SP602524M-03	Sleeve										
BS602524M-03	Ball & Sleeve										
BP602524H-03	Ball	24	20.4-27.6	0.12	2.88	3800	0.55	19.5	4.12	0.162	29.6
SP602524H-03	Sleeve										
BS602524H-03	Ball & Sleeve										

## Dimensions (mm)

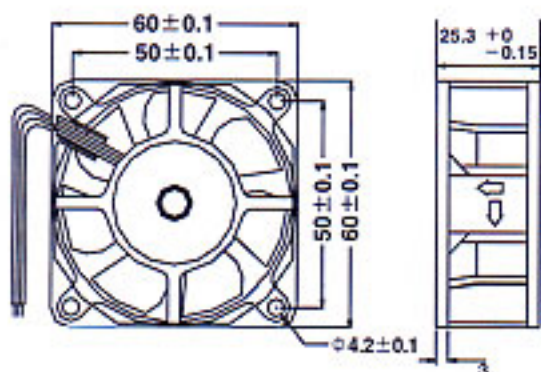

## Performance Curve

