

DIMENSIONS FOR SELECTIVE PLATING'S, SCALE 4:1

- NOTES:
- 1: FOR MATERIAL SPECIFICATION SEE NOTE 1. ON SHEET 2.
 - 2: FOR RECOMMENDED P.C.B.HOLE PATTERN, PART No's AND UNSTATED DIMENSIONS SEE SHEET 2.
 - 3: PRODUCT SPEC. No. :PS 99020-0015

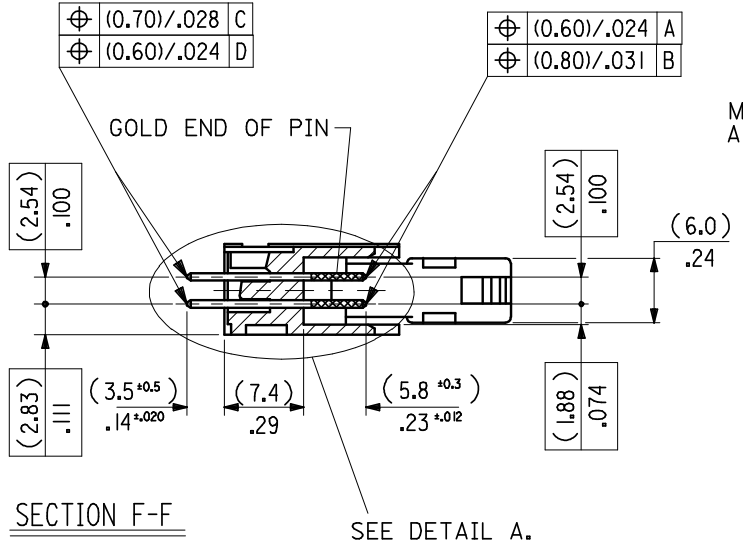

CHANGED GEN TOL. EC NO: E2008-0461 DRWN: NIKI ERNAN 2008/03/05 CHKD: 2008/03/06 APPR: BMAGUIRE 2008/03/06	QUALITY SYMBOLS ▼ = ▽ =	GENERAL TOLERANCES (UNLESS SPECIFIED)		DIMENSION STYLE IN/MM	SCALE 2:1	DESIGN UNITS INCH	THIRD ANGLE PROJECTION		
		4 PLACES ± --- ±	3 PLACES ± ±	DRAWN BY SM	DATE 3 /8/90	TITLE QIK FLECS WIPE FEMALE MOLEX INCORPORATED			
REV	DESCRIPTION	2 PLACES ±0.15 ±.005	1 PLACE ±0.02 ±.008	CHECKED BY X	DATE	DOCUMENT NO. SDA-90571			
		ANGULAR ±1/2°		APPROVED BY X	DATE	SHEET NO. 1 OF 4			
DRAFT WHERE APPLICABLE MUST REMAIN WITHIN DIMENSIONS				MATERIAL NO.	THIS DRAWING CONTAINS INFORMATION THAT IS PROPRIETARY TO MOLEX INCORPORATED AND SHOULD NOT BE USED WITHOUT WRITTEN PERMISSION				

(78.74)/3.100	(86.34)/3.400	(90.52)/3.564	(96.62)/3.804	(100.74)/3.966	90571-1641	90571-1642	90571-1643	64	
(73.66)/2.900	(81.26)/3.200	(85.44)/3.364	(91.54)/3.604	(95.66)/3.766	↑ -1601	↑ -1602	↑ -1603	60	
(60.96)/2.400	(68.56)/2.700	(72.74)/2.864	(78.84)/3.104	(82.96)/3.266	-1501	-1502	-1503	90571-1509	
(48.26)/1.900	(55.86)/2.200	(60.04)/2.364	(66.14)/2.604	(70.26)/2.766	-1401	-1402	-1403	↑ -1409	
(40.64)/1.600	(48.24)/1.900	(52.42)/2.064	(58.52)/1.304	(62.64)/2.466	-1341	-1342	-1343	-1349	
(35.56)/1.400	(43.16)/1.700	(47.34)/1.864	(53.44)/2.104	(57.56)/2.266	-1301	-1302	-1303	-1309	
(30.48)/1.200	(38.08)/1.500	(42.26)/1.664	(48.36)/1.904	(52.48)/2.066	-1261	-1262	-1263	-1269	
(22.86)/.900	(30.46)/1.200	(34.64)/1.364	(40.74)/1.604	(44.86)/1.766	-1201	-1202	-1203	-1209	
(17.78)/.700	(25.38)/1.000	(29.56)/1.164	(35.66)/1.404	(39.78)/1.566	-1161	-1162	-1163	-1169	
(15.24)/.600	(22.84)/.900	(27.02)/1.064	(33.12)/1.304	(37.24)/1.466	↓ -1141	↓ -1142	↓ -1143	↓ -1149	
(10.16)/.400	(17.76)/.700	(21.94)/.864	(28.04)/1.104	(32.16)/1.266	90571-1101	90571-1102	90571-1103	90571-1109	
A	B	C	D	E	ENG. NO. GS1 PLATING	ENG. NO. GS2 PLATING	ENG. NO. GS3 PLATING	ENG. NO. PRE TIN	NO.OF CKTS.

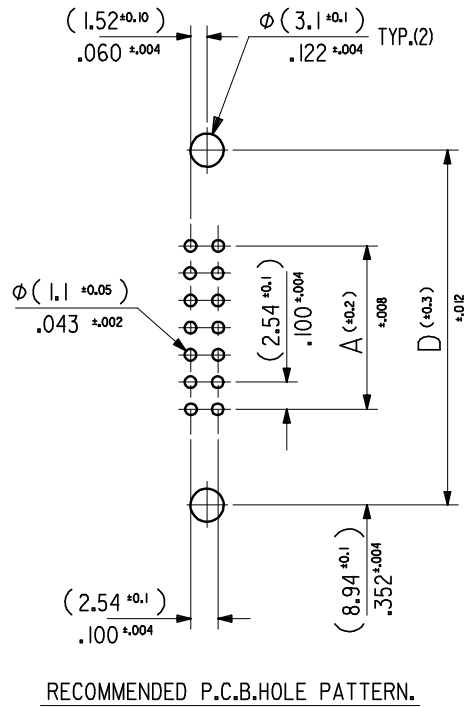

NOTES

1.MATERIAL

HEADER : GLASS FILLED POLYESTER (UL 94V0), COLOUR - BLACK.
 PINS : BRASS SIZE \square (0.635)/.025 .
 LEVER : GLASS FILLED POLYESTER (UL 94V0), COLOUR - BLACK.

2.COLOUR IDENTIFICATION MARK FOR PLATING OPTIONS.

90571-1**1, (1um)/39uin MIN. NICKEL UNDERPLATE. CONTACT AREA
 GS1 PLATING (0.1um)/4uin MIN. GOLD. SOLDER AREA (3um)/118uin MIN.
 TIN. COLOUR MARK: YELLOW.
 90571-1**2, (1um)/39uin MIN. NICKEL UNDERPLATE. CONTACT AREA
 GS2 PLATING (0.76um)/30uin MIN. GOLD. SOLDER AREA (3um)/118uin MIN.
 TIN. COLOUR MARK: BROWN.
 90571-1**3, (1um)/39uin MIN. NICKEL UNDERPLATE. CONTACT AREA
 GS3 PLATING (0.25um)/10uin MIN. GOLD. SOLDER AREA (3um)/118uin MIN.
 TIN. COLOUR MARK: BLUE.
 90571-1**9, (0.5-1um)/20-40uin NICKEL UNDER (1.0-3.0um)/39-118uin TIN.
 PRE-TIN COLOUR MARK: BLACK, (NO MARK).

3. RECOMMENDED PCB THICKNESS 1.6mm

CHANGED GEN TOL. EC NO: E2008-0461 DRWN:ILK/ERNAN 2008/03/05 CHKD: 2008/03/06 APPR:BMAGUIRE 2008/03/06	QUALITY SYMBOLS 	GENERAL TOLERANCES (UNLESS SPECIFIED)		DIMENSION STYLE IN/MM		SCALE 2:1	DESIGN UNITS INCH	THIRD ANGLE PROJECTION	
		4 PLACES ± --- ±	mm INCH	DRAWN BY SM SM	DATE 3 / 8 / 2008	TITLE QIK FLECS HEADER WITH DIN EJECT LEVERS FOR IMPROVED WIPE FEMALE			
		3 PLACES ± ±	± 0.15 ± 0.05	CHECKED BY X	DATE	MOLEX INCORPORATED			
		2 PLACES ± 0.20 ± 0.08	ANGULAR ±1/2°	APPROVED BY X	DATE	MATERIAL NO. SEE CHART	DOCUMENT NO. SDA-90571	SHEET NO. 2 OF 4	
1 PLACE ± 0.20 ± 0.08	DRAFT WHERE APPLICABLE MUST REMAIN WITHIN DIMENSIONS	SIZE A3		THIS DRAWING CONTAINS INFORMATION THAT IS PROPRIETARY TO MOLEX INCORPORATED AND SHOULD NOT BE USED WITHOUT WRITTEN PERMISSION					