

Power SMD LED in PLCC-2 Package

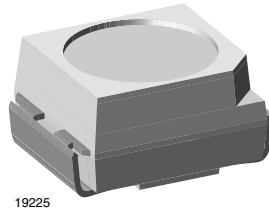

FEATURES

- Available in 8 mm tape
- ESD-withstand voltage: up to 2 kV according to JESD22-A114-B
- Compatible with IR-reflow, vapor phase and wave solder processes according to CECC 00802 and J-STD-020C
- Preconditioning: acc. to JEDEC Level 2a
- Automotive qualified
- Lead (Pb)-free device
- Component in accordance to RoHS 2002/95/EC and WEEE 2002/96/EC



DESCRIPTION

The VLMK33.. series is an advanced modification of the Vishay VLMK33.. series. It is designed to incorporate larger chips, therefore, capable of withstanding a 50 mA drive current.

The package of the VLMK33.. is the PLCC-2 (equivalent to a size B tantalum capacitor).

It consists of a lead frame which is embedded in a white thermoplast. The reflector inside this package is filled up with clear epoxy.

APPLICATIONS

- Interior and exterior lighting
- Indicator and backlighting purposes for audio, video, LCDs, switches, symbols, illuminated advertising etc.
- Illumination purpose, alternative to incandescent lamps
- Automotive qualified
- General use

PARTS TABLE

PART	COLOR, LUMINOUS INTENSITY	ANGLE OF HALF INTENSITY ($\pm \varphi$)	TECHNOLOGY
VLMK33Q2T1-GS08	Red, $I_V > (90 \text{ to } 355) \text{ mcd}$	60°	AllnGaP on GaAs
VLMK33Q2T1-GS18	Red, $I_V > (90 \text{ to } 355) \text{ mcd}$	60°	AllnGaP on GaAs
VLMK33R1S2-GS08	Red, $I_V = (112 \text{ to } 280) \text{ mcd}$	60°	AllnGaP on GaAs
VLMK33R1S2-GS18	Red, $I_V = (112 \text{ to } 280) \text{ mcd}$	60°	AllnGaP on GaAs
VLMK33S1T1-GS08	Red, $I_V = (180 \text{ to } 355) \text{ mcd}$	60°	AllnGaP on GaAs
VLMK33S1T1-GS18	Red, $I_V = (180 \text{ to } 355) \text{ mcd}$	60°	AllnGaP on GaAs



ABSOLUTE MAXIMUM RATINGS ¹⁾ VLMK33..				
PARAMETER	TEST CONDITION	SYMBOL	VALUE	UNIT
Reverse voltage ²⁾		V_R	5	V
DC Forward current		I_F	50	mA
Power dissipation		P_V	130	mW
Junction temperature		T_j	125	°C
Operating temperature range		T_{amb}	- 40 to + 100	°C
Storage temperature range		T_{stg}	- 40 to + 100	°C
Soldering temperature	$t \leq 5$ s	T_{sd}	260	°C
Thermal resistance junction/ambient	mounted on PC board (pad size > 16 mm ²)	R_{thJA}	400	K/W

Note:

1) $T_{amb} = 25$ °C unless otherwise specified

2) Driving LED in reverse direction is suitable for a short term application

OPTICAL AND ELECTRICAL CHARACTERISTICS ¹⁾ , VLMK33.., RED							
PARAMETER	TEST CONDITION	PART	SYMBOL	MIN	TYP.	MAX	UNIT
Luminous intensity	$I_F = 20$ mA	VLMK33Q2T1	I_V	90		355	mcd
		VLMK33R1S2	I_V	112		280	mcd
		VLMK33S1T1	I_V	180		355	mcd
Luminous flux/Luminous intensity			ϕ_V/I_V		3.14		mlm/mcd
Dominant wavelength	$I_F = 20$ mA		λ_d	611	617	624	nm
Peak wavelength	$I_F = 20$ mA		λ_p		624		nm
Spectral bandwidth at 50 % $I_{rel\ max}$	$I_F = 20$ mA		$\Delta\lambda$		18		nm
Angle of half intensity	$I_F = 20$ mA		φ		± 60		deg
Forward voltage	$I_F = 20$ mA		V_F		1.9	2.5	V
Reverse current	$V_R = 5$ V		V_R		0.01	10	μ A

Note:

1) $T_{amb} = 25$ °C unless otherwise specified

LUMINOUS INTENSITY CLASSIFICATION		
GROUP	LUMINOUS INTENSITY (MCD)	
	MIN	MAX
Q1	71	90
Q2	90	112
R1	112	140
R2	140	180
S1	180	224
S2	224	280
T1	280	355
T2	355	450

Note:

Luminous intensity is tested at a current pulse duration of 25 ms and an accuracy of ± 11 %.

The above type Numbers represent the order groups which include only a few brightness groups. Only one group will be shipped on each reel (there will be no mixing of two groups on each reel). In order to ensure availability, single brightness groups will be not orderable. In a similar manner for colors where wavelength groups are measured and binned, single wavelength groups will be shipped on any one reel. In order to ensure availability, single wavelength groups will be not orderable.

COLOR CLASSIFICATION		
GROUP	DOMINANT WAVELENGTH (NM)	
	RED	
	MIN	MAX
1	611	618
2	614	622
3		
4		
5		
6		

Note:

Wavelength are tested at a current pulse duration of 25 ms and an accuracy of ± 1 nm

CROSSING TABLE	
VISHAY	OSRAM
VLMK33Q2T1	LAT676-Q2T1
VLMK33R1S2	LAT676-R1S2
VLMK33S1T1	LAT676-S1T1

TYPICAL CHARACTERISTICS

$T_{amb} = 25\text{ }^{\circ}\text{C}$ unless otherwise specified

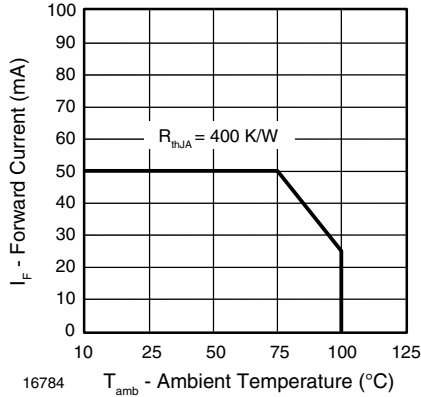

Figure 1. Forward Current vs. Ambient Temperature

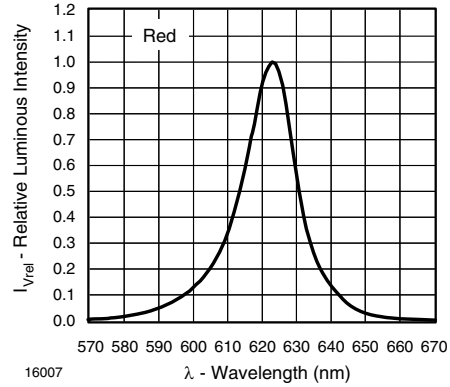

Figure 4. Rel. Luminous Intensity vs. Angular Displacement

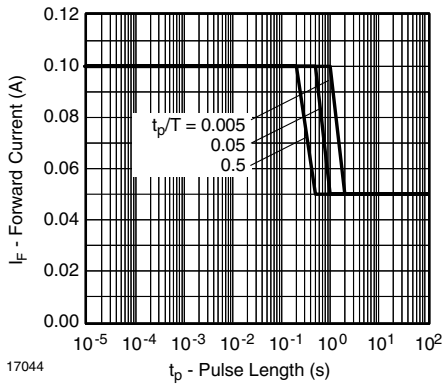

Figure 2. Forward Current vs. Pulse Length

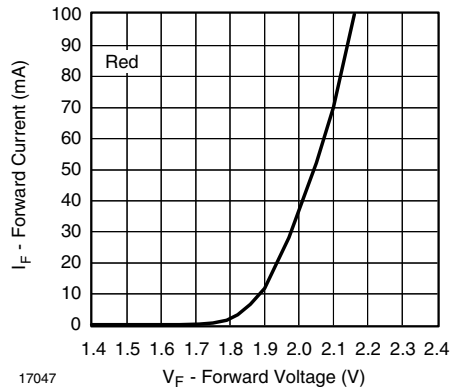

Figure 5. Forward Current vs. Forward Voltage

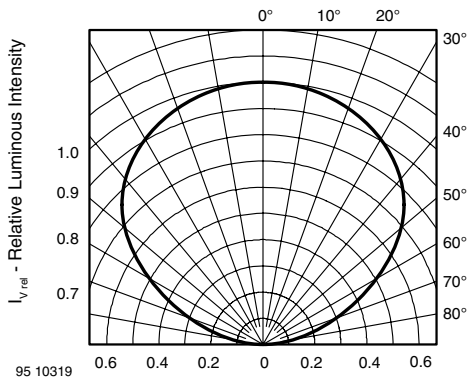

Figure 3. Rel. Luminous Intensity vs. Angular Displacement

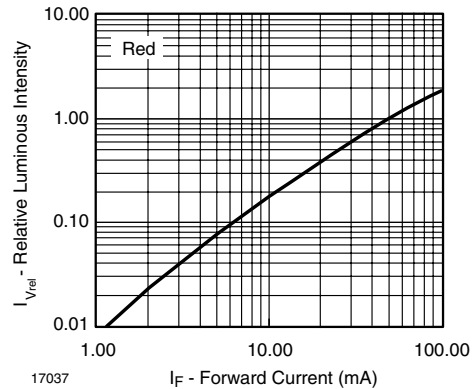

Figure 6. Change of Dominant Wavelength vs. Forward Current

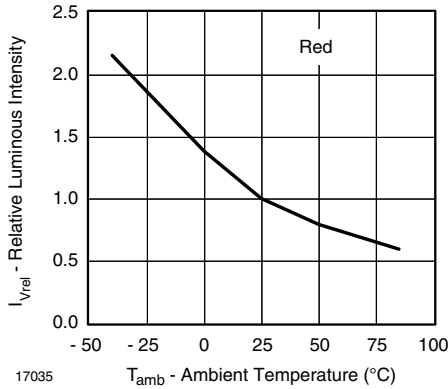

Figure 7. Relative Luminous Intensity vs. Amb. Temperature

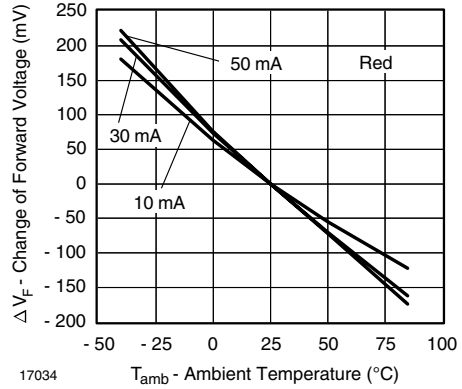

Figure 9. Change of Forward Voltage vs. Ambient Temperature

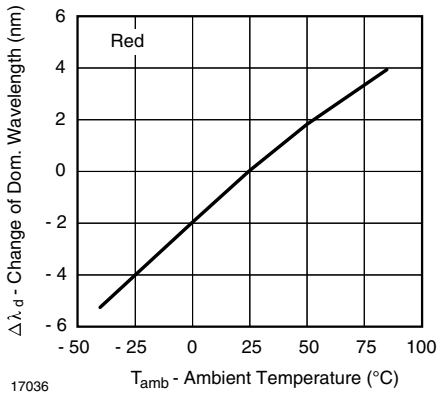
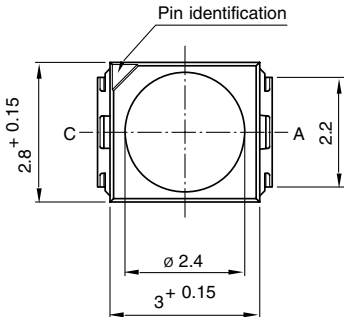
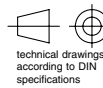
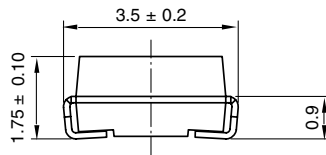

Figure 8. Change of Dominant Wavelength vs. Ambient Temperature

PACKAGE DIMENSIONS IN MM



Drawing-No. : 6.541-5025.01-4
Issue: 8; 22.11.05

95 11314-1

Mounting Pad Layout

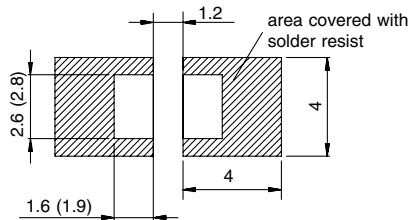

Dimensions: IR Reflow and Vaporphase (Wave Soldering)

METHOD OF TAPING/POLARITY AND TAPE AND REEL

SMD LED (VLM3 - SERIES)

Vishay's LEDs in SMD packages are available in an antistatic 8 mm blister tape (in accordance with DIN IEC 40 (CO) 564) for automatic component insertion. The blister tape is a plastic strip with impressed component cavities, covered by a top tape.

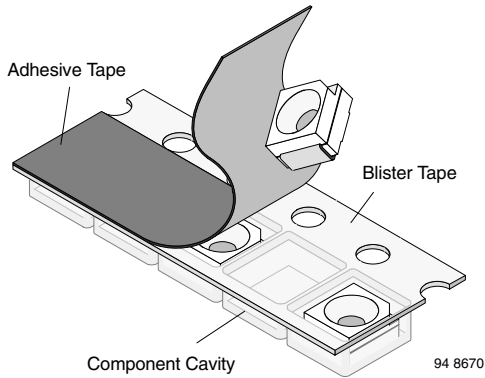

REEL PACKAGE DIMENSION IN MM FOR SMD LEDS, TAPE OPTION GS08 (= 1500 PCS.)

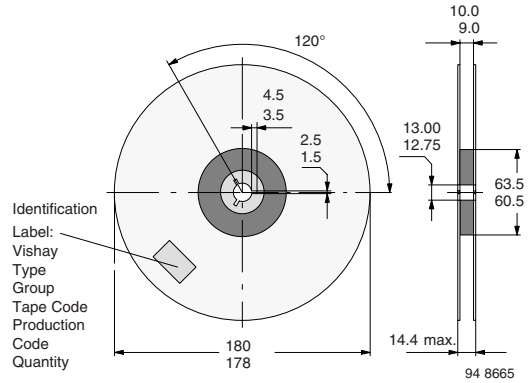

Figure 11. Reel dimensions - GS08

TAPING OF VLM.3..

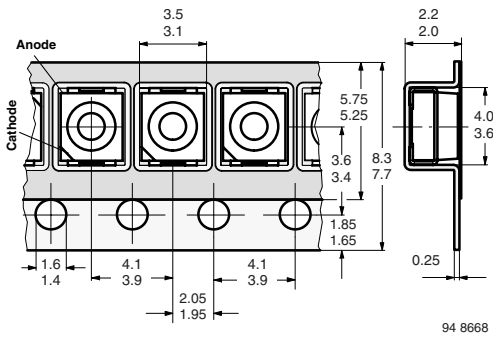

Figure 10. Tape dimensions in mm for PLCC-2

REEL PACKAGE DIMENSION IN MM FOR SMD LEDS, TAPE OPTION GS18 (= 8000 PCS.) PREFERRED

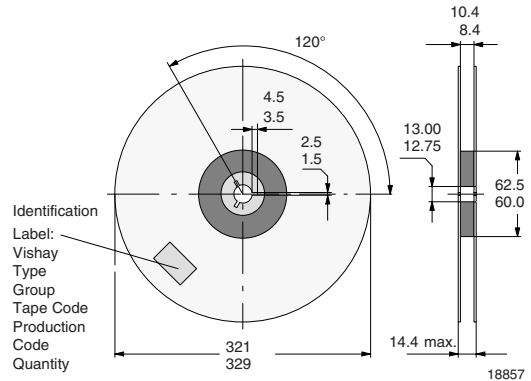

Figure 12. Reel dimensions - GS18

SOLDERING PROFILE

**BARCODE-PRODUCT-LABEL
EXAMPLE:**

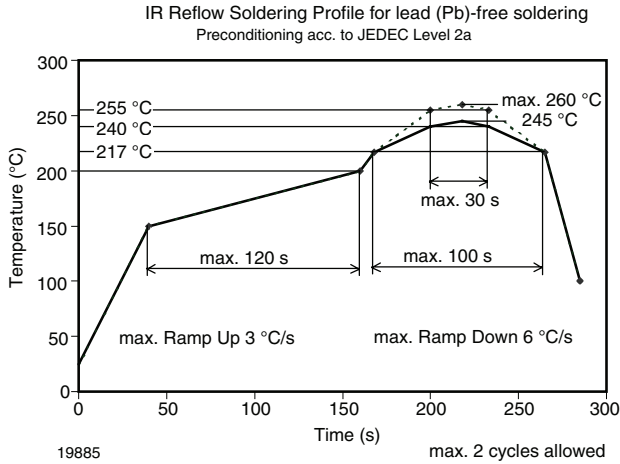
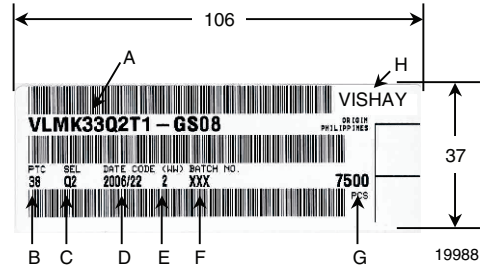

Figure 13. Vishay Lead (Pb)-free Reflow Soldering Profile (acc. to J-STD-020C)



- A) Type of component
- B) Manufacturing Plant
- C) SEL - Selection Code (Bin):
e.g.: Q2 = Code for Luminous Intensity Group
- D) Date Code year/week
- E) Day Code (e.g. 2: Tuesday)
- F) Batch No.
- G) Total quantity
- H) Company Code

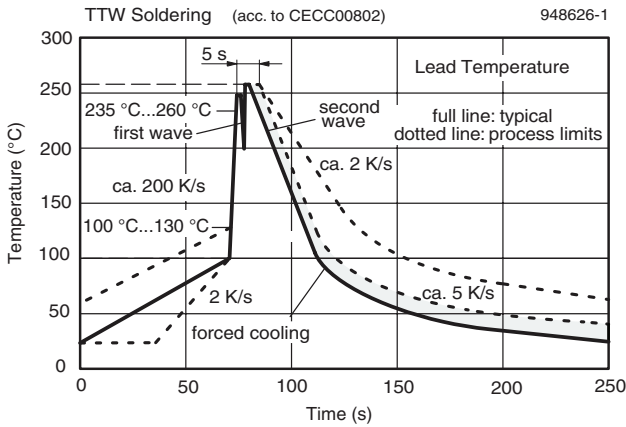

Figure 14. Double wave soldering of opto devices (all packages)

**OZONE DEPLETING SUBSTANCES POLICY STATEMENT**

It is the policy of Vishay Semiconductor GmbH to

1. Meet all present and future national and international statutory requirements.
2. Regularly and continuously improve the performance of our products, processes, distribution and operating systems with respect to their impact on the health and safety of our employees and the public, as well as their impact on the environment.

It is particular concern to control or eliminate releases of those substances into the atmosphere which are known as ozone depleting substances (ODSs).

The Montreal Protocol (1987) and its London Amendments (1990) intend to severely restrict the use of ODSs and forbid their use within the next ten years. Various national and international initiatives are pressing for an earlier ban on these substances.

Vishay Semiconductor GmbH has been able to use its policy of continuous improvements to eliminate the use of ODSs listed in the following documents.

1. Annex A, B and list of transitional substances of the Montreal Protocol and the London Amendments respectively
2. Class I and II ozone depleting substances in the Clean Air Act Amendments of 1990 by the Environmental Protection Agency (EPA) in the USA
3. Council Decision 88/540/EEC and 91/690/EEC Annex A, B and C (transitional substances) respectively.

Vishay Semiconductor GmbH can certify that our semiconductors are not manufactured with ozone depleting substances and do not contain such substances.

We reserve the right to make changes to improve technical design
and may do so without further notice.

Parameters can vary in different applications. All operating parameters must be validated for each customer application by the customer. Should the buyer use Vishay Semiconductors products for any unintended or unauthorized application, the buyer shall indemnify Vishay Semiconductors against all claims, costs, damages, and expenses, arising out of, directly or indirectly, any claim of personal damage, injury or death associated with such unintended or unauthorized use.

Vishay Semiconductor GmbH, P.O.B. 3535, D-74025 Heilbronn, Germany



Notice

Specifications of the products displayed herein are subject to change without notice. Vishay Intertechnology, Inc., or anyone on its behalf, assumes no responsibility or liability for any errors or inaccuracies.

Information contained herein is intended to provide a product description only. No license, express or implied, by estoppel or otherwise, to any intellectual property rights is granted by this document. Except as provided in Vishay's terms and conditions of sale for such products, Vishay assumes no liability whatsoever, and disclaims any express or implied warranty, relating to sale and/or use of Vishay products including liability or warranties relating to fitness for a particular purpose, merchantability, or infringement of any patent, copyright, or other intellectual property right.

The products shown herein are not designed for use in medical, life-saving, or life-sustaining applications. Customers using or selling these products for use in such applications do so at their own risk and agree to fully indemnify Vishay for any damages resulting from such improper use or sale.