

THIS DRAWING IS UNPUBLISHED. RELEASED FOR PUBLICATION JUNE, 2004.
 © COPYRIGHT 2004 BY TYCO ELECTRONICS CORPORATION. ALL RIGHTS RESERVED.

Loc	DIST	REVISIONS					
E	B	P	LTR	DESCRIPTION	DATE	DWN	APVD
		B		ECR-05-006587	05AUG05	JMS	FWK

- NOTES**
- 1 SINGLE PACK IN ACCORDANCE WITH AMP SPEC 107-3275
 - 2 100 TRAY PACK IN ACCORDANCE WITH AMP SPEC 107-3275
 - 3 Au PLATING OVER Ni PLATING OVER Cu PLATING
 - 4 Ni PLATING OVER Cu PLATING
 5. HAND TOOL: 9-1478240-0
 6. DIE SET: SEE TABLE
 7. **CHARACTERISTICS**
 FREQUENCY RANGE: DC-2GHz
 NOMINAL IMPEDANCE: 75 OHMS
 INSULATION RESISTANCE: 5000 MOHMS
 DIELECTRIC WITHSTAND VOLTAGE: 1500V RMS
 WORKING VOLTAGE: 500V MAX AT SEA LEVEL
 CONTACT RESISTANCE: CENTRE CONTACT 1.5 mOHMS
 OUTER CONTACT 0.2 mOHMS
 8. **MECHANICAL CHARACTERISTICS**
 DURABILITY: 50 CYCLES
 9. FOR TECHNICAL DATA REFER TO YOUR LOCAL TYCO ELECTRONICS SALES OFFICE
 10. ALL DIMENSIONS ARE NOMINAL FOR REFERENCE ONLY UNLESS OTHERWISE STATED

		-	-	0.4	4.5	3.1	9-1478242-0	RG179B/U, 187A/U, URM111	5-1634502-5
		-	-	0.4	4.5	3.1	9-1478242-0	RG179B/U, 187A/U, URM111	5-1634502-4
		7.4	6.5	0.7	5.45	3.8	9-1478242-0	RG59B/U, 62A/U, 140/U, 210/U, URM90, KX 6A, KX 25, KX 52, KX 53	5-1634502-3
		7.4	6.5	0.7	5.45	3.8	9-1478242-0	RG59B/U, 62A/U, 140/U, 210/U, URM90, KX 6A, KX 25, KX 52, KX 53	5-1634502-2
		6.4	5.4	0.7	4.5	3.1	9-1478242-0	E4205, NEK23795, SDTV-A-LFH, 36-516/519, IMAGE360, RA7000	5-1634502-1
		6.4	5.4	0.7	4.5	3.1	9-1478242-0	E4205, NEK23795, SDTV-A-LFH, 36-516/519, IMAGE360, RA7000	5-1634502-0
		E	D	C	B	A	DIE SET	CABLE GROUPS	PART NO.

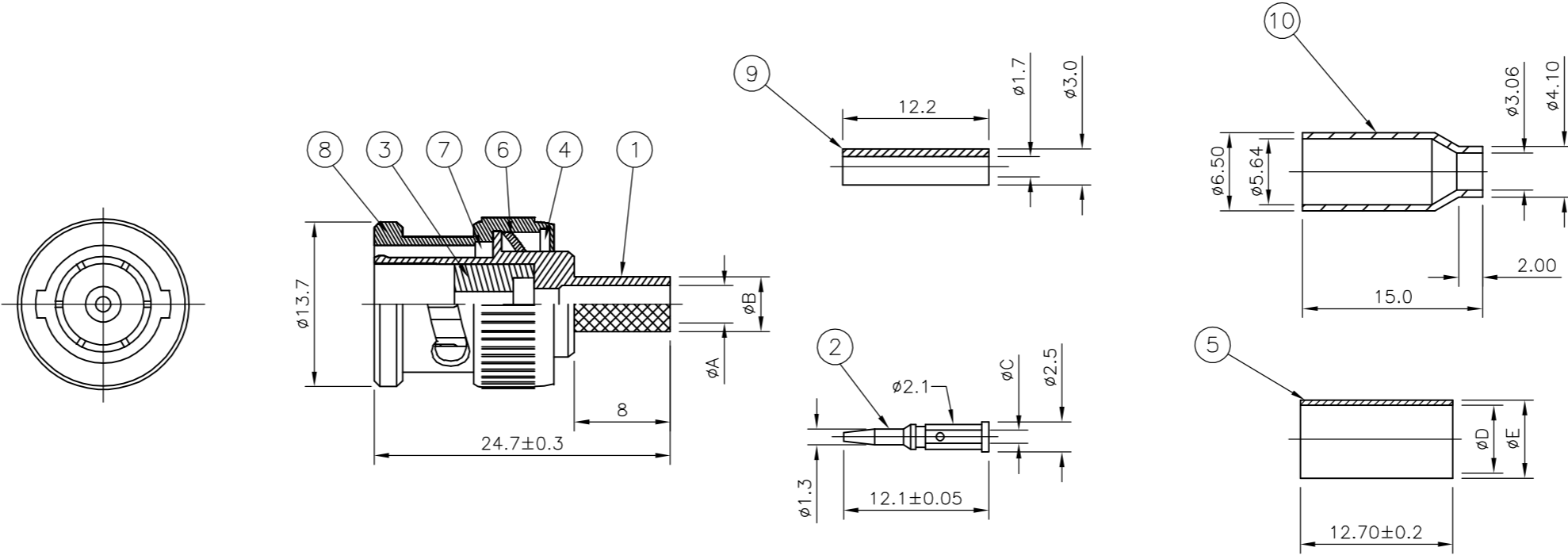

	1	1	-	-	-	-	BRASS	⚠	CRIMP SLEEVE	10
	1	1	-	-	-	-	NYLON		PUSHER SLEEVE	9
	1	1	1	1	1	1	ZINC ALLOY	⚠	BARREL	8
	1	1	1	1	1	1	SILCON RUBBER		GASKET	7
	1	1	1	1	1	1	SPRING STEEL		SPRING	6
	-	-	1	1	1	1	BRASS	⚠	CRIMP SLEEVE	5
	1	1	1	1	1	1	BRASS	⚠	WASHER	4
	1	1	1	1	1	1	POLYMETHYLPENTENE		INSULATOR	3
	1	1	1	1	1	1	BRASS	⚠	CONTACT	2
	1	1	1	1	1	1	ZINC ALLOY	⚠	BODY	1
	5	5	4	5	3	5	MATERIAL		DESCRIPTION	ITEM

THIS DRAWING IS A CONTROLLED DOCUMENT.

DWN: J.SANDWELL 16JUN04
 CHK: S.PARLOW 16JUN04
 APVD: F.WHEELER-KING 16JUN04

Product Spec: 108-3435
 Application Spec: SEE SHEET 2

Material: SEE TABLE
 Finish: SEE TABLE

Tolerances unless otherwise specified:
 0 PLC ±
 1 PLC ±
 2 PLC ±
 3 PLC ±
 4 PLC ±
 ANGLES ±

Customer Drawing: A2 00779 C=1634502

Scale: NTS
 Sheet: 1 of 2
 Rev: B

Quantity per Assy: 10, 9, 8, 7, 6, 5, 4, 3, 2, 1

Parts List: CRIMP SLEEVE, PUSHER SLEEVE, BARREL, GASKET, SPRING, CRIMP SLEEVE, WASHER, INSULATOR, CONTACT, BODY

1634502

THIS DRAWING IS UNPUBLISHED. RELEASED FOR PUBLICATION JUNE , 2004.
 © COPYRIGHT 2004 BY TYCO ELECTRONICS CORPORATION. ALL RIGHTS RESERVED.

LOC		DIST		REVISIONS			
P	LTR	DESCRIPTION	DATE	DWN	APVD		
-	-	SEE SHEET 1	-	-	-		

COMPONENTS

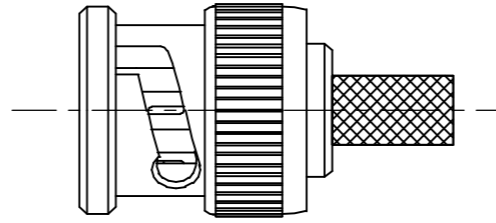
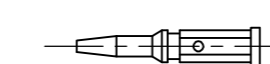
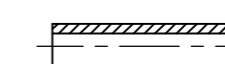
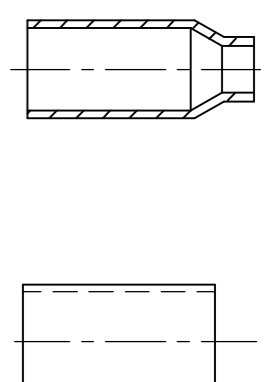
MAIN BODY (ITEM 1,3,4,6,7 & 8)	CENTRE CONTACT (ITEM 2)	PUSHER SLEEVE (ITEM 9)	CRIMP FERRULES (ITEM 5 & 10)
			

ASSEMBLY INSTRUCTION

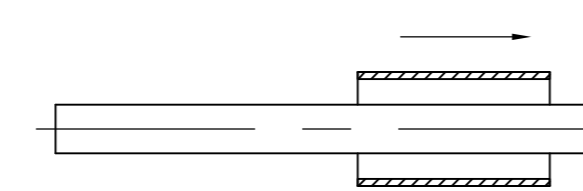
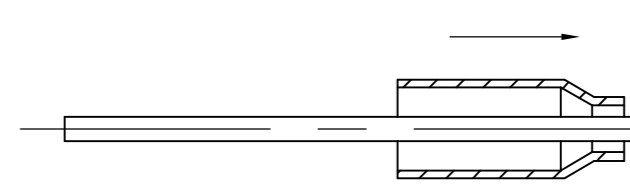
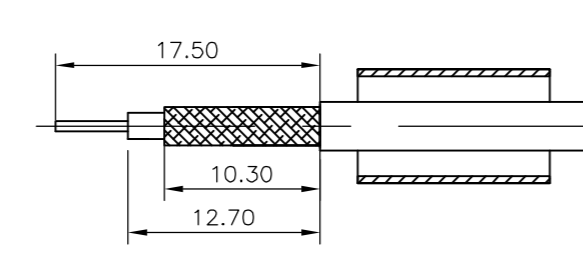
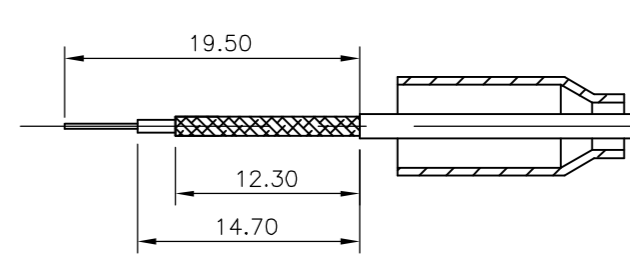
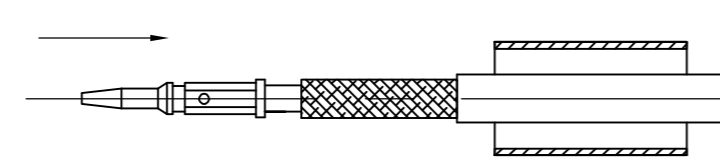
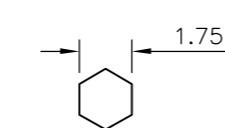
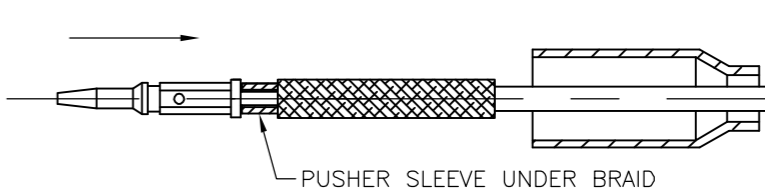
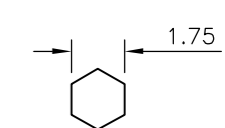
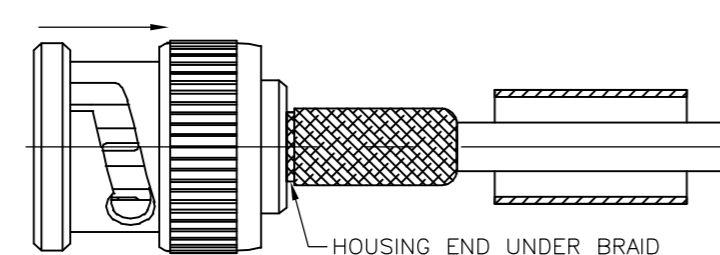
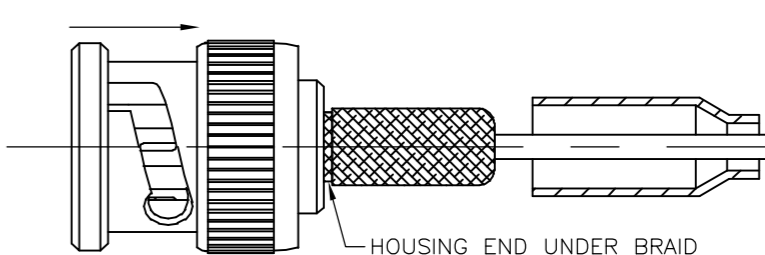
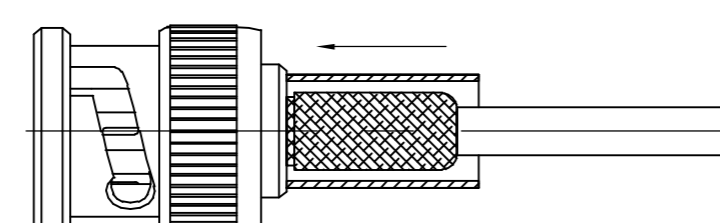
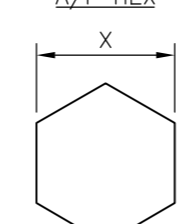
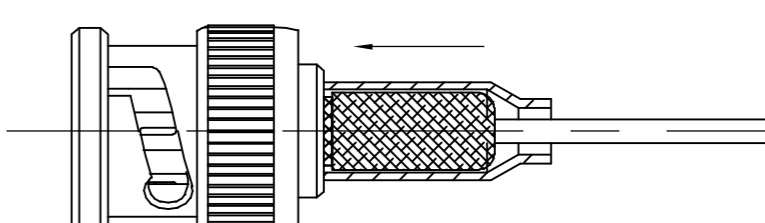
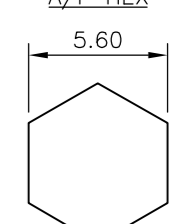
CABLES: RG59B/U, 62A/U, 140/U, 210/U, URM90, KX 6A, KX 25, KX 52, KX 53, RG58C/U, 141A/U, URM43, 76, BELDEN 9907, KX 15	CABLES: RG179B/U, 187A/U, URM111
<p>STEP 1</p> <p>1. SLIDE METAL CRIMP FERRULE OVER CABLE</p> 	<p>STEP 1</p> <p>1. SLIDE METAL CRIMP FERRULE OVER CABLE</p> 
<p>STEP 2</p> <p>1. STRIP CABLE TO DIMENSIONS AS SHOWN</p> 	<p>STEP 2</p> <p>1. STRIP CABLE TO DIMENSIONS AS SHOWN</p> 
<p>STEP 3</p> <p>1. FIT CONTACT OVER CENTRE CONDUCTOR TO BUTT AGAINST DIELECTRIC. 2. CRIMP USING TOOL AS NOTES ON PAGE 1.</p>  <p>RECOMMENDED CENTRE CONTACT A/F HEX</p> 	<p>STEP 3</p> <p>1. SLIDE ITEM 10 PUSHER SLEEVE OVER DIELECTRIC BEFORE FITTING THE CONTACT. 2. FIT CONTACT OVER CENTRE CONDUCTOR TO BUTT AGAINST DIELECTRIC. 3. CRIMP USING TOOL AS NOTES ON PAGE 1.</p>  <p>RECOMMENDED CENTRE CONTACT A/F HEX</p> 
<p>STEP 4</p> <p>1. PRESS SUB-ASSEMBLY INTO BODY, UNTIL CONTACT IS FULLY LOCATED BY AN AUDIBLE CLICK. 2. ENSURE THAT KNURLED HOUSING INSERTS BETWEEN THE DIELECTRIC AND CABLE BRAID.</p> 	<p>STEP 4</p> <p>1. PRESS SUB-ASSEMBLY INTO BODY, UNTIL CONTACT IS FULLY LOCATED BY AN AUDIBLE CLICK. 2. ENSURE THAT KNURLED HOUSING INSERTS BETWEEN THE PUSHER SLEEVE AND CABLE BRAID.</p> 
<p>STEP 5</p> <p>1. SLIDE CRIMP FERRULE ALONG THE CABLE UNTIL IT BUTTS AGAINST THE HOUSING BODY. 2. CRIMP USING TOOL AS NOTED ON PAGE 1. 3. CRIMP DIMENSION X IS:- RG59B (SEE PAGE 1 FOR FULL CABLE LIST) = 6.50 RG58C/U (SEE PAGE 1 FOR FULL CABLE LIST) = 5.60</p>  <p>RECOMMENDED CRIMP SLEEVE A/F HEX</p> 	<p>STEP 5</p> <p>1. SLIDE CRIMP FERRULE ALONG THE CABLE UNTIL IT BUTTS AGAINST THE BODY HOUSING. 2. CRIMP USING TOOL AS NOTED ON PAGE 1. 3. CRIMP DIMENSION AS SHOWN.</p>  <p>RECOMMENDED CRIMP SLEEVE A/F HEX</p> 

THIS DRAWING IS A CONTROLLED DOCUMENT.		DWN J.SANDWELL 16JUN04	tyco Tyco Electronics Corporation	
DIMENSIONS: mm		CHK S.PARLOW 16JUN04	Bideford, UK, EX39 4HE	
TOLERANCES UNLESS OTHERWISE SPECIFIED		APVD F.WHEELER-KING 16JUN04	NAME	
0 PLC ± 1 PLC ± 2 PLC ± 3 PLC ± 4 PLC ± ANGLES ±		PRODUCT SPEC 108-3435	BNC STRAIGHT PLUG HEX CRIMP 75 OHM	
MATERIAL SEE TABLE		FINISH SEE TABLE	WEIGHT -	RESTRICTED TO -
SEE TABLE		SEE TABLE	SCALE NTS	SHEET 2 OF 2
CUSTOMER DRAWING		REV B	DRAWING NO C=1634502	

1634502