

THE INFORMATION CONTAINED IN THIS DRAWING IS THE SOLE PROPERTY OF L-COM, INC. ANY REPRODUCTION IN PART OR WHOLE WITHOUT THE WRITTEN PERMISSION OF L-COM, INC. IS PROHIBITED.

REVISIONS			
REV	DESCRIPTION	DATE	APPROVED
A	APPROVED FOR PRODUCTION BY: D.DOLCE	01/30/04	B.MAZEJKA

SVGA PINOUT TABLE		
PIN	SIGNAL	WIRE
1	RED	COAX CC
2	GREEN	COAX CC
3	BLUE	COAX CC
4	ID BIT 2	TP 1
5	GROUND	TP1
6	RED SHIELD	COAX SHLD
7	GREEN SHIELD	COAX SHLD
8	BLUE SHIELD	COAX SHLD
9	DDV +5V	COND 1
10	SYNC RTN	TP 3/4
11	ID BIT 0	TP 2
12	ID BIT 1	TP 2
13	HORZ SYNC	COND 2
14	VER SYNC	TP 3
15	ID BIT 3	TP 4
16	SHELL	DRAIN WIRE

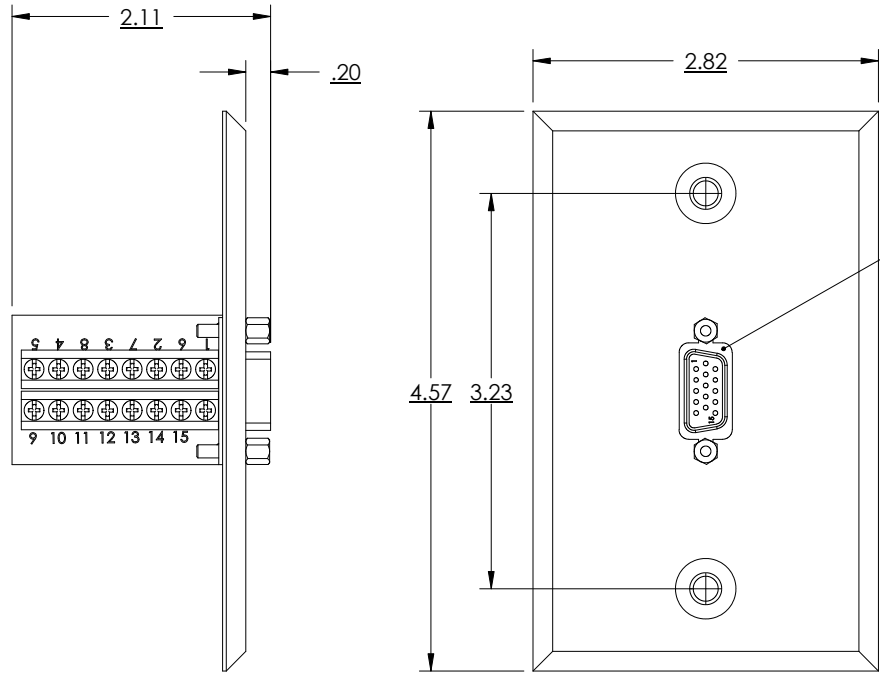

J1  
SVGA HD15 JACK  
FIELD TERMINATION  
w/ FEMALE, 15-CONTACT  
HIGH DENSITY D-SUB CONN  
AND 2X 8-POS TERMINAL BLOCKS

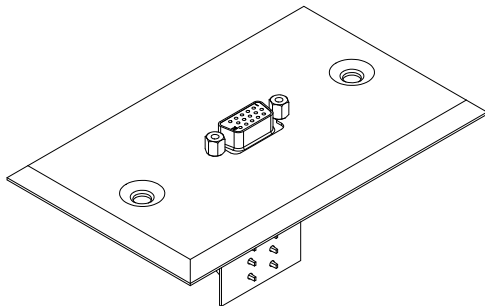

NOTES:

1. WALL PLATE MATERIAL: STAINLESS STEEL

UNLESS OTHERWISE SPECIFIED,  
DIMENSIONS ARE IN INCHES  
TOLERANCES ARE:  
.XX ±.01  
.XXX ±.005  
  
CABLE LENGTH TOLERANCE  
<300" ±5% >300" ±2%

APPROVALS	DATE
DRAWN BY B.MAZEJKA	09/22/2003
CHECKED BY D.PARHAM	09/26/2003
APPROVED BY C.McCORMICK	09/26/2003

**L-com**  
CONNECTIVITY  
PRODUCTS  
45 BEECHWOOD DRIVE  
NORTH ANDOVER, MA  
01845

PRODUCT DESCRIPTION  
SVGA HD15 JK FIELD TERMINATION w/ WALL PLATE

DRAWING TITLE  
**OUTLINE DRAWING**

SIZE <b>A</b>	FSCM NO. <b>43321</b>	DWG. NO. <b>WPHD15FT-OD1</b>	REV <b>A</b>
------------------	--------------------------	---------------------------------	-----------------

SCALE: 1:1.5 CAD FILE: WPHD15FT-OD1.SLDDRW SHEET 1 OF 1

CONFIGURATION DETAILS OF  
UNDIMENSIONED FEATURES  
MAY VARY