

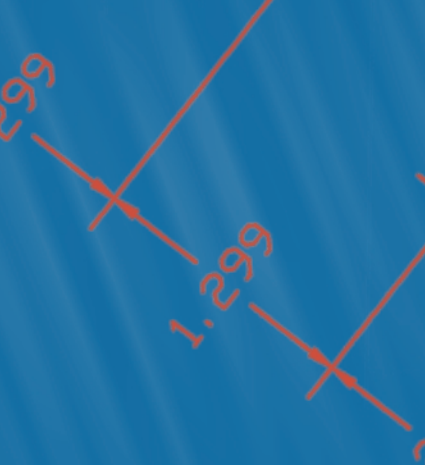

YOKOGAWA

POWER TRANSDUCER CATALOG

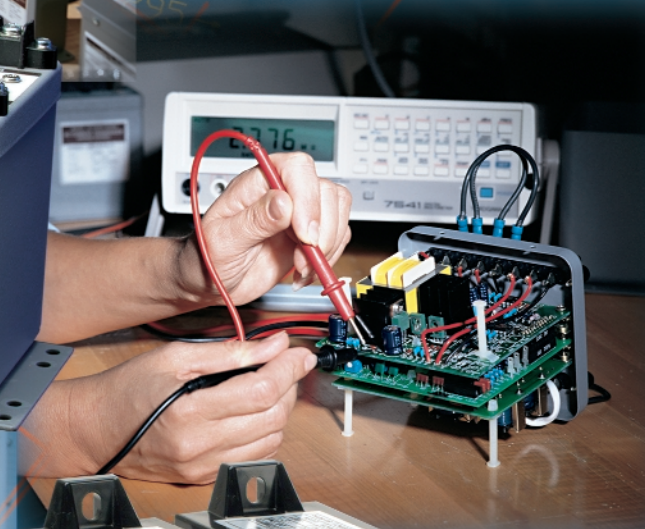

YOKOGAWA TRANSDUCERS

Thank you for your interest in Yokogawa's Power Transducer Product Line. This catalog includes the Juxta AC Power Series transducers which are manufactured just-in-time at our Newnan, Georgia facility. This enables YCA to offer very quick delivery and prompt customer service. Also included are the Miniature Plastic Case transducers available in foot mount style as well as DIN rail mount. With this wide array, YCA can surely meet most any power transducer application you may have.

Since our establishment in the United States in 1957, Yokogawa Corporation of America (YCA) has become a leading North American manufacturer and supplier of Test and Measurement, Field Instrumentation (Flow, Pressure and Analytical Products), Process Control Equipment, Information Products

Headquartered just south of Atlanta, Georgia, YCA has sales offices across the United States. Our commitment to our customers is our number one priority, and we back it up with a network of representatives and distributors that reflect this commitment. Our 132 manufacturing and service locations give us a presence on every major continent, which means we have the global resources to support all your application needs.

Our parent company, Yokogawa Electric Corporation, is dedicated to developing the most advanced control and instrumentation products and systems in the world. As a major global player, the company anticipates the needs of the times, continually tackling new challenges and exploring new markets in order to provide the best solutions in the world.

Yokogawa's commitment to innovation is reflected in our extraordinary investments in R&D, which ensure development of the most advanced products and services. As a result, we have secured more than 4,500 patents and registrations, representing a number of important innovations, including the world's first distributed control system and the first digital sensors for flow and pressure measurement.

PRODUCT OVERVIEW

Yokogawa's JUXTA "AC POWER SERIES" transducers (2469 & 2489) are rugged metal case designs for utility and industrial applications. Most models are UL recognized under File E60579 and exceed IEEE472/ANSI C37.90.1 Surge Withstand Capability test. The "SWC" test assures maximum protection from damaging line transients caused by switchgear operation or lightning strikes upstream on the system.

Typically, power transducers provide a reliable and accurate analog DC output proportional to the AC input from the secondary of potential and / or current transformers in switchgear or control enclosures. The output is usually linked to remote monitoring equipment such as meters, recorders, PLC's, SCADA systems, Energy Management Systems, etc. Usually, 0.5% accuracy is adequate for most industrial monitoring needs. Our 2469 meets this requirement. Most power utility applications, however, require a higher level of accuracy. Our 2489 series, with 0.2% accuracy, is recommended for such applications.

The plastic case power transducers (2370 & 2460 series) offer versatility and compactness when panel space is tight. The 2460 series can be mounted on a DIN rail, along with relays and terminal blocks, to maximize space and provide the ultimate in flexibility to the panel designer. The 2370 series has the same height and width as the DIN rail mount, but has two mounting feet which only require two drill holes and half the space of most metal case transducers. Both of these models offer 0.5% accuracy and come in one uniform case size from AC Amps to 3P4W Watts or Vars.

Both of these products evolved from Yokogawa's original 2280 series Power Line Transducer design which is broadly accepted throughout the world. For information on the 2281 through 2289 models, please request bulletin 2280-E from Yokogawa on our reply card inserted in the catalog.

Yokogawa offers a complete line of transducers for expansion, retrofit or upgrade of your power system. We hope the specification data and associated information in this catalog will provide all that is needed to make our transducers your choice for reliable power monitoring in your plant or equipment design.

TABLE OF CONTENTS

JUXTA METAL CASE TRANSDUCERS - 0.2% AND 0.5% ACCURACY	
AC CURRENT TRANSDUCERS (true RMS and Average sensing)	PAGE 2
AC VOLTAGE TRANSDUCERS (true RMS and Average sensing)	PAGE 4
DC TO DC ISOLATORS	PAGE 6
AC WATT TRANSDUCERS	PAGE 8
AC VAR TRANSDUCERS	PAGE 10
COMBINATION WATT / VAR TRANSDUCERS	PAGE 12
POWER FACTOR TRANSDUCERS	PAGE 14
PHASE ANGLE TRANSDUCERS	PAGE 16
FREQUENCY TRANSDUCERS	PAGE 18
JUXTA 2489 SERIES ACCURACY	PAGE 20
SELECTING A WATT OR VAR TRANSDUCER	PAGE 21
TRANSDUCER TERMINOLOGY	PAGE 22
PLASTIC CASE MINIATURE TRANSDUCERS - 0.5% ACCURACY	
2371-2378 FOOT MOUNT / 2461-2468 DIN RAIL MOUNT	PAGE 24

JUXTA AC CURRENT TRANSDUCERS

1) GENERAL

The 2469 and 2489 AC Average Current transducers produce an analog DC signal output corresponding to the average value of the AC input. The true RMS versions always require external power and produce an analog DC output corresponding to the true RMS value of the input signal.

2) SPECIFICATIONS

Model #	2469	2489
Input Current	0-1 Amp AC or 0-5 Amp AC	
Input over range capability	200% of rated input continuous 1000% of rated input for 5 seconds	
Input Burden	<0.2VA per element	
Rated outputs	0-1mADC into 10 kΩ max. load; 10VDC output compliance 4-20 mADC into 750Ω max. load; 15VDC output compliance	
Accuracy 10-100% of rated input	0-1mADC=±0.5% of full scale 4-20mADC=±0.5% of span	0-1mADC=±0.2% of full scale 4-20mADC=±0.2% of span
External calibration adjustment	Zero: ±1% minimum(AHD only) Span: ± 2% minimum	Zero: ±5% minimum(AHD only) Span: ± 10% minimum
Response time	<400 milliseconds(0-99% of output)	
Output ripple	0.3% of span peak-to-peak max.	0.5% of span peak-to-peak max.
Isolation	2500 VAC input to output, power and case 2000 VAC aux. power to output and case (AHD and TRMS) 500 VAC output to case	
Surge Withstand Capability	IEEE472/ANSI C37.90.1 - 1989, JIS C1111(5KV, 1.2 x 50 microseconds)	
Insulation resistance	>10 megohm / 500VDC input/output/power/case	
Operating temperature	-20°C to +60°C	
Operating humidity	0 - 90% relative humidity (non-condensing)	
Temperature effect	± 250 PPM / °C of span	± 140 PPM / °C of span
External magnetic field	< 0.2% at 400 AT/m	
Input frequency range	50 - 500 Hz < 0.2% effect on accuracy	
Influence of frequency	< 0.2%, 45-65 Hz, fundamental through 9th harmonic (TRMS models only)	
Weight	TRMS = 900g, 0-1mA = 358g, 4-20mA = 897g, 3 in 1 = 1100g	
Shock	< 0.2% after 50G, 3 Axis and 6 repetitions	
Vibration	< 0.2% after 16.7 Hz, 4 mmp-p 1 hour, 3 Axis	
UL Recognition	File # E60579	

3) STANDARD MODELS

0-5 Amp AC, 60 HZ input	2469 (0.5% Accuracy)	2489 (0.2% Accuracy)
AVG./0-1 mA output / self powered TRMS / 0-1mA output / 120V aux. power AVG./4-20mA output / 120V aux. power TRMS / 4-20mA / 120V aux. power 3 in 1 / 0-1mA output / self-powered	246921-380-AFA-0 246931-380-AFA-1 246921-380-AHD-1 246931-380-AHD-1 246923-380-AFA-0	248921-380-AFA-0 248931-380-AFA-1 248921-380-AHD-1 248931-380-AHD-1 248923-380-AFA-0

NOTE: See order format on next page for additional ratings, frequency calibrations, power-up and output options. Auxiliary power supply options <5.0 VA burden.

JUXTA AC CURRENT TRANSDUCERS

4) ORDER FORMAT 2469 / 89 - -

Model#	(1) Transducer function	(2) Input	(3) Input frequency	(4) Output	(5) Aux. power
2469	21 Average current	37 0-1 Amp AC	0 60 Hz	AFA 0-1 mADC (21 & 23 only)	0 Input powered
2489	23 3 in 1 Avg. current	38 0-5 Amp AC	1 50 Hz	AFA 0-1 mADC (TRMS only) AHD 4-20 mADC (21 & 31 only)	1 85-135 VAC 2 170-264 VAC
	31 True RMS current		2 50/60 Hz		
			4 400 Hz		
			5 Other		

5) CONNECTION DIAGRAMS FOR CT INPUT

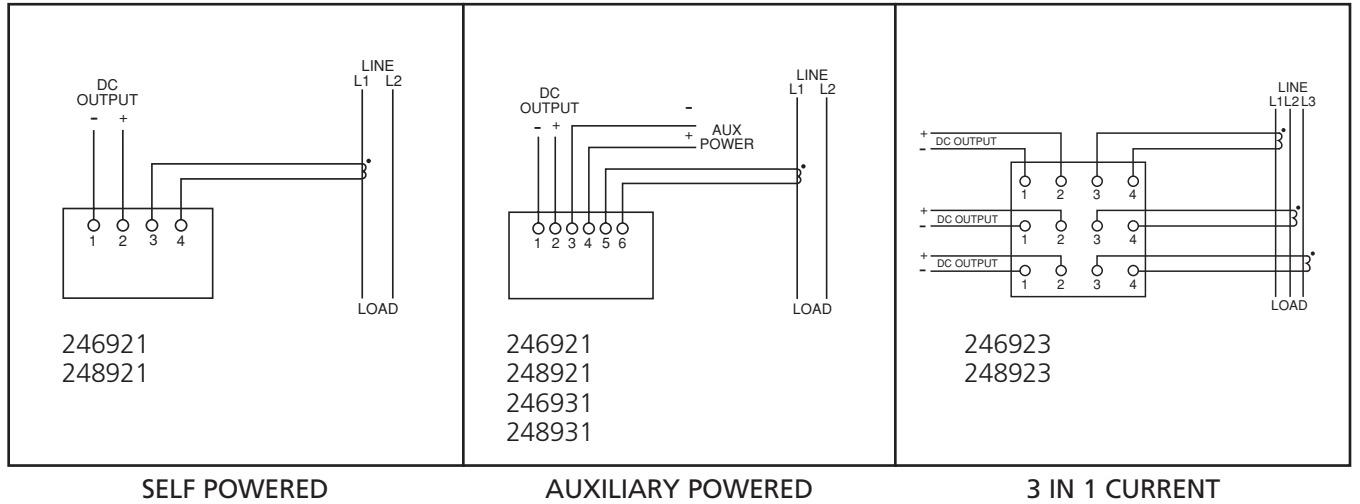

6) MOUNTING AND OUTLINE DIMENSIONS: (mm) inches

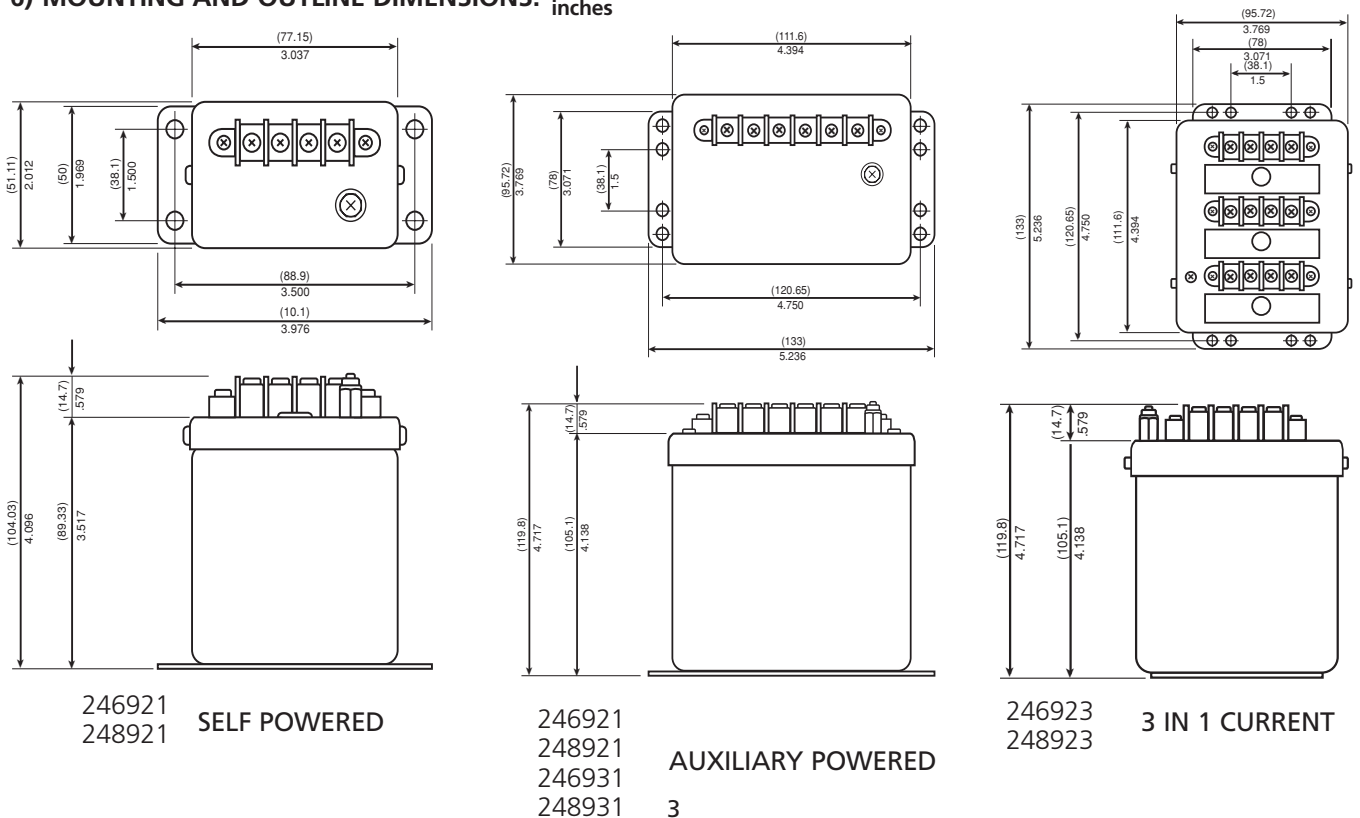

JUXTA AC VOLTAGE TRANSDUCERS

1) GENERAL

The 2469 and 2489 AC Average Voltage transducers produce an analog DC signal output corresponding to the average value of the AC input. The true RMS versions always require external power and produce an analog DC output corresponding to the true RMS value of the input signal.

2) SPECIFICATIONS

Model #	2469	2489
Input Voltage	0-150 VAC or 0-300 VAC	
Input over range capability	120% of rated input continuous	
Input Burden (Averaging models)	150 VAC: <1.8VA / element; 300 VAC: <3.6VA / element	
Input Burden (true RMS models)	150 VAC: <0.8VA; 300 VAC: <1.6VA	
Rated outputs	0-1mADC into 10 kΩmax. load; 10VDC output compliance 4-20 mADC into 750Ω max. load; 15VDC output compliance	
Accuracy 10-100% of rated input	0-1mADC=±0.5% of full scale 4-20mADC=±0.5% of span	0-1mADC=±0.2% of full scale 4-20mADC=±0.2% of span
External calibration adjustment	Zero: ±1% minimum(AHD only) Span: ±2% minimum	Zero: ±5% minimum(AHD only) Span: ±10% minimum
Response time	<400 milliseconds(0-99% of output)	
Output ripple	0.3% of span peak-to-peak max.	0.5% of span peak-to-peak max.
Isolation	2500 VAC input to output, power and case 2000 VAC aux. power to output and case(AHD + TRMS) 500 VAC output to case	
Surge Withstand Capability	IEEE472/ANSI C37.90.1 - 1989, JIS C1111(5KV 1.2 x 50 microseconds)	
Insulation resistance	>10 megohm / 500VDC input/output/power/case	
Operating temperature	-20°C to +60°C	
Operating humidity	0 - 90% relative humidity (non-condensing)	
Temperature drift	± 250 PPM / °C of span	± 140 PPM / °C of span
External magnetic field	< 0.2% at 400 AT/m	
Input frequency range	50 - 500 Hz < 0.2% effect on accuracy	
Influence of frequency	< 0.2%, 45-65 Hz, fundamental through 9th harmonic (TRMS models only)	
Weight	TRMS = 900g, 0-1mA = 358g, 4-20mA = 897g, 3 in 1 = 1100g	
Shock	< 0.2% after 50G, 3 Axis and 6 repetitions	
Vibration	< 0.2% after 16.7 Hz, 4 mmp-p 1 hour, 3Axis	
UL Recognition	File # E60579	

3) STANDARD MODELS

0-150 VAC, 60 HZ input	2469 (0.5% Accuracy)	2489 (0.2% Accuracy)
AVG./0-1 mA / self powered TRMS / 0-1mA / 120V aux. power AVG./4-20mA / 120V aux. power TRMS / 4-20mA / 120V aux. power 3 in 1 / 0-1mA output / self-powered	246922-330-AFA-0 246932-330-AFA-1 246922-330-AHD-1 246932-330-AHD-1 246924-330-AFA-0	248922-330-AFA-0 248932-330-AFA-1 248922-330-AHD-1 248932-330-AHD-1 248924-330-AFA-0

NOTE: See order format on next page for additional ratings, frequency calibrations, power-up and output options. Auxiliary power supply options <5.0 VA burden.

JUXTA AC VOLTAGE TRANSDUCERS

4) ORDER FORMAT 2469 / 89 - | | |

Model#	(1) Transducer function	(2) Input	(3) Input frequency	(4) Output	(5) Aux. power*
2469	22 Average Voltage	33 0-150 VAC	0 60 Hz	AFA 0-1 mADC (22 & 24 only)	0 Input powered
2489	24 3 in 1 Avg. Voltage	36 0-300 VAC	1 50 Hz		
	32 True RMS Voltage		2 50/60 Hz		
			4 400 Hz		
			5 Other	AFA 0-1 mADC (TRMS only)	1 85-135 VAC
				AHD 4-20 mADC (22 & 32 only)	2 170-264 VAC

*Contact Factory
For Other Power
Supply Options

5) CONNECTION DIAGRAMS FOR PT INPUT

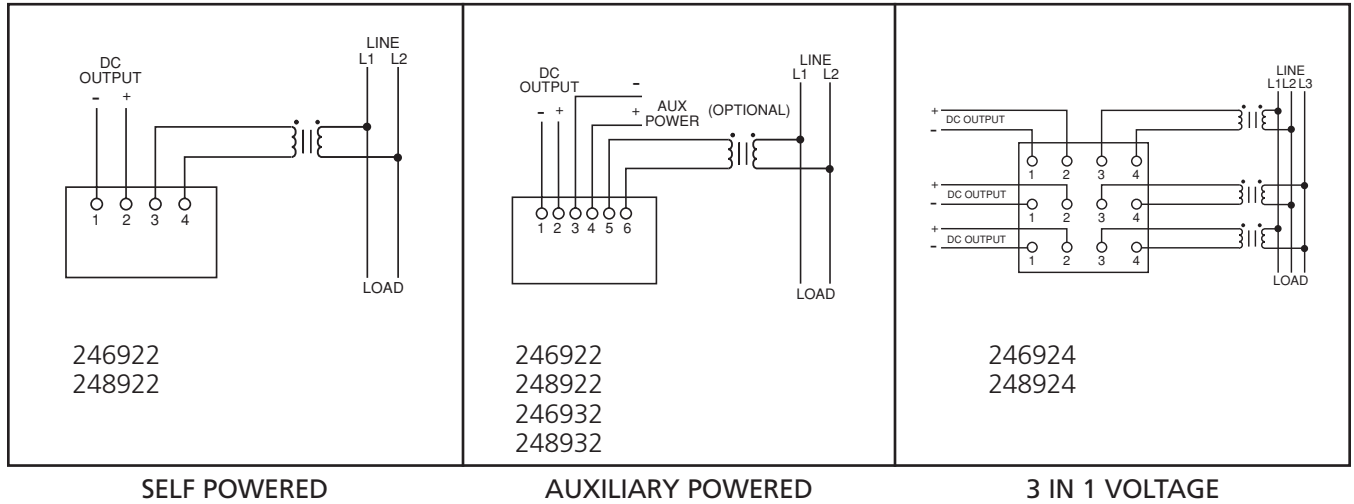

6) MOUNTING AND OUTLINE DIMENSIONS: (mm) inches

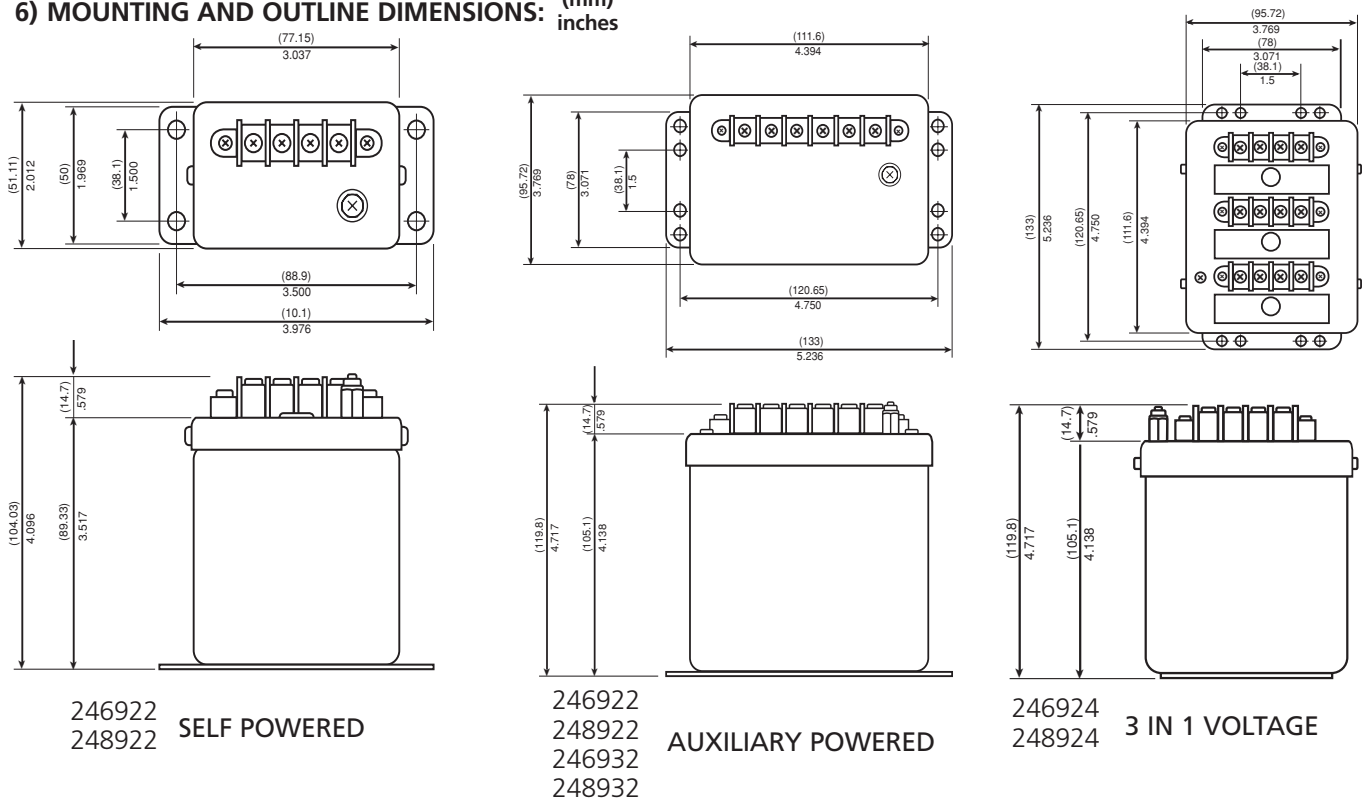

J U X T A D C T O D C I S O L A T O R S

1) GENERAL

The 2469 series DC to DC isolator provides an isolated analog output proportional to the DC voltage or current input. Standard inputs are 50mVDC and 1 mADC. Auxiliary power is required to power the DC to DC isolator. Other DC inputs and power options are available on special order from Yokogawa.

2) SPECIFICATIONS

Model #	2469 (0.5% accuracy)
Input signal ranges	0-50mVDC and 0-1mADC are standard
Input impedance	Varies with input current or voltage
Input burden	< 1 mADC
Output compliance	10 VDC
Accuracy 10-100% rated input	± 0.5% of full scale
Span adjustment	± 5% minimum
Zero adjustment	± 5% minimum
Response time	< 500 milliseconds (0-99% of output)
Isolation	2600 VAC input to output, power and case 1000 VAC aux. power to output and case 1000 VAC output to case
Surge withstand capability	IEEE472/ANSI C37.90.1-1989 SWC TEST
Operating temperature	0° C to +40° C
Operating humidity	20 - 90% relative humidity (non-condensing)
Weight	908g (2 lbs.)
Auxiliary Power Supply	115V AC ±10%, 5.0 VA Burden

3) STANDARD MODELS

Model # Description	Input / Output Relationship
246911-001-AFA-1 / DC Voltage input	0-50mVDC / 0-1mADC
246911-001-AHD-1 / DC Voltage input	0-50mVDC / 4-20mADC
246911-001-VMT-1 / DC Voltage input	0-50mVDC / 0-10VDC
246912-101-AFA-1 / DC Current input	0-1mADC / 0-1mADC
246912-101-AHD-1 / DC Current input	0-1mADC / 4-20mADC
246912-101-VMT-1 / DC Current input	0-1mADC / 0-10VDC

J U X T A D C T O D C I S O L A T O R S

4) ORDER FORMAT 2469 (1) (2) (3) (4)

Model#	(1) Transducer function	(2) Input	(3) Output	(4) Aux. power
2469	11 DC Voltage input	001 0-50 mVDC	AFA 0-1mADC	1 115VAC ±10%
	12 DC Current input	101 0-1 mADC	AHD 4-20mADC	
			VMT 0-10VDC	

Consult factory for other input / output / power-up options

5) CONNECTION DIAGRAMS

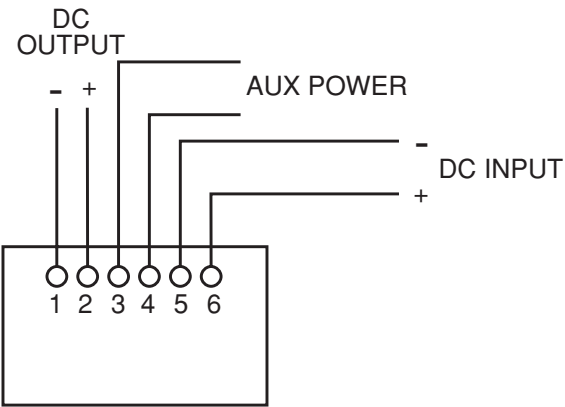

6) MOUNTING AND OUTLINE DIMENSIONS: (mm)
inches

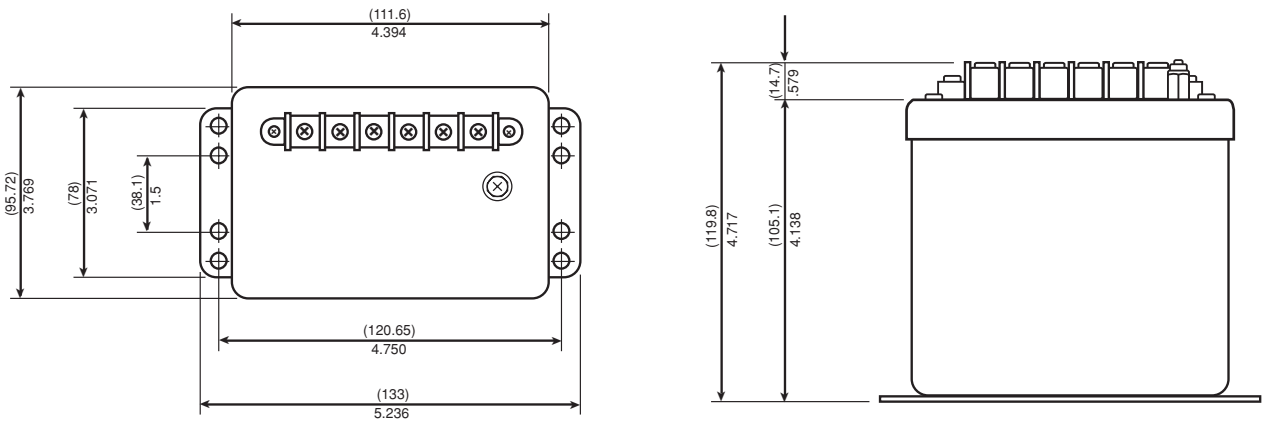

J U X T A A C W A T T T R A N S D U C E R S

1) GENERAL

The 2469 and 2489 AC Watt transducers produce an analog output equal to the Watts measured by the input. The typical calibration is 500 Watts / element for 120V and 5A AC transformer secondary inputs.

2) SPECIFICATIONS

Model #	2469	2489
Current input / range	0-1 Amp AC or 0-5 Amp AC 10 to 200% of rated input 0-200% of rated input	
Current input over range capability	200% of rated input continuous 1000% of rated input for 5 seconds	
Current input burden	< 0.2VA per element	
Voltage inputs and range: Input powered range Auxiliary powered range	120V 100-135VAC 0-120% rated input < 0.5VA	240V 200-264VAC 0-120% of rated input < 1.0VA
Voltage input burden per element	< 0.3VA	< 0.6VA
Sustained Voltage input overrange	150% of rated input without damage (Auxiliary powered only)	
Rated outputs	0 to ±1mADC into 10kΩ max. load; 10VDC output compliance 4-20 mADC into 750Ω max. load; 15VDC output compliance	
Accuracy	0 ± 1mADC = 0.5% of full scale 4-20mADC = 0.5% of span	0±1mADC = ±0.1% rdg. ± 0.05%FS 4-20mADC = ±0.2% of span
Output calibration / element	120VAC: 1 Amp = 0-100 Watts; 5 Amp = 0-500 Watts 240VAC: 1 Amp = 0-200 Watts; 5 Amp = 0-1000 Watts	
External calibration adjustment	Zero: ± 1% minimum Span: ± 2% minimum	Zero: ± 5% minimum Span: ± 10% minimum
Response time	< 400 milliseconds (0-99% of output)	
Output ripple	0.3% of span peak-to-peak max.	0.5% of span peak-to-peak max.
Isolation	2500 VAC input to output, power and case 2000 VAC aux. power to output and case 500 VAC output to case	
Surge Withstand Capability	IEEE472/ANSI C37.90.1 - 1989, JIS C1111 (5KV 1.2 x 50 microseconds)	
Insulation resistance	> 10 megohm / 500VDC input/output/power/case	
Operating temperature	-20°C to +60°C	1mA (-20°to+70°C), 4-20mA(-20°to+60°C)
Operating humidity	0 - 90% relative humidity (non-condensing)	
Temperature effect	±250 PPM / °C of span	1mA ±50FS, 4-20mA ±75span (PPM/°C)
External magnetic field	< 0.2% at 400 AT/m	
Influence : unbalanced currents / phase interaction / Power Factor	<0.5%	<0.2%
Influence of frequency	<0.25%, 45-65 Hz, fundamental through 9th harmonic	
Weight	1200g (2.65 lbs.)	
Shock	<0.2% after 50G, 3 Axis and 6 repetitions	
Vibration	<0.2% after 16.7 Hz, 4 mmp-p 1 hour, 3 Axis	
UL Recognition	File # E60579	

3) STANDARD MODELS

120 VAC, 5AAC, 60 Hz, input powered	2469 (0.5% Accuracy)	2489 (0.2% Accuracy)
Watt 1P2W, 0-1mA output (1 Element)	246951-540-AFA-0	248951-540-AFA-0
Watt 1P2W, 4-20mA output (1 Element)	246951-540-AHD-0	248951-540-AHD-0
Watt 3P3W, 0-1mA output (2 Element)	246953-540-AFA-0	248953-540-AFA-0
Watt 3P3W, 4-20mA output (2 Element)	246953-540-AHD-0	248953-540-AHD-0
Watt 3P4W, 0-1mA output (2½ Element)	246954-540-AFA-0	248954-540-AFA-0
Watt 3P4W, 4-20mA output (2½ Element)	246954-540-AHD-0	248954-540-AHD-0
Watt 3P4W, 0-1mA output (3 Element)	246955-540-AFA-0	248955-540-AFA-0
Watt 3P4W, 4-20mA output (3 Element)	246955-540-AHD-0	248955-540-AHD-0

NOTE: See order format on next page for additional ratings, frequency calibrations, power-up and output options.
Auxiliary power supply options <5.0 VA burden.

JUXTA AC WATT TRANSDUCERS

4) ORDER FORMAT 2469 / 89 - -

Model#	(1) Transducer function	(2) Input	(3) Input frequency	(4) Output	(5) Aux. power**
2469	51 Watt 1P2W (1 Element)	53 120VAC/ 1AAC	0 60 Hz	AFA 0-1 mADC	0 Input powered
2489	52 Watt 3P3W (1½ Element)*	54 120VAC/ 5AAC	1 50 Hz	AFB ±1 mADC	1 120 VAC 2 240 VAC
	53 Watt 3P3W (2 Element)	57 240VAC/ 1AAC	4 400 Hz	AHD 4-20 mADC	
	54 Watt 3P4W (2½ Element)	58 240VAC/ 5AAC	5 Other	AHF 12±8 mADC	
	55 Watt 3P4W (3 Element)				

*Not UL

**Contact Factory For Other Power Supply Options

5) CONNECTION DIAGRAMS WITH PT AND CT INPUTS

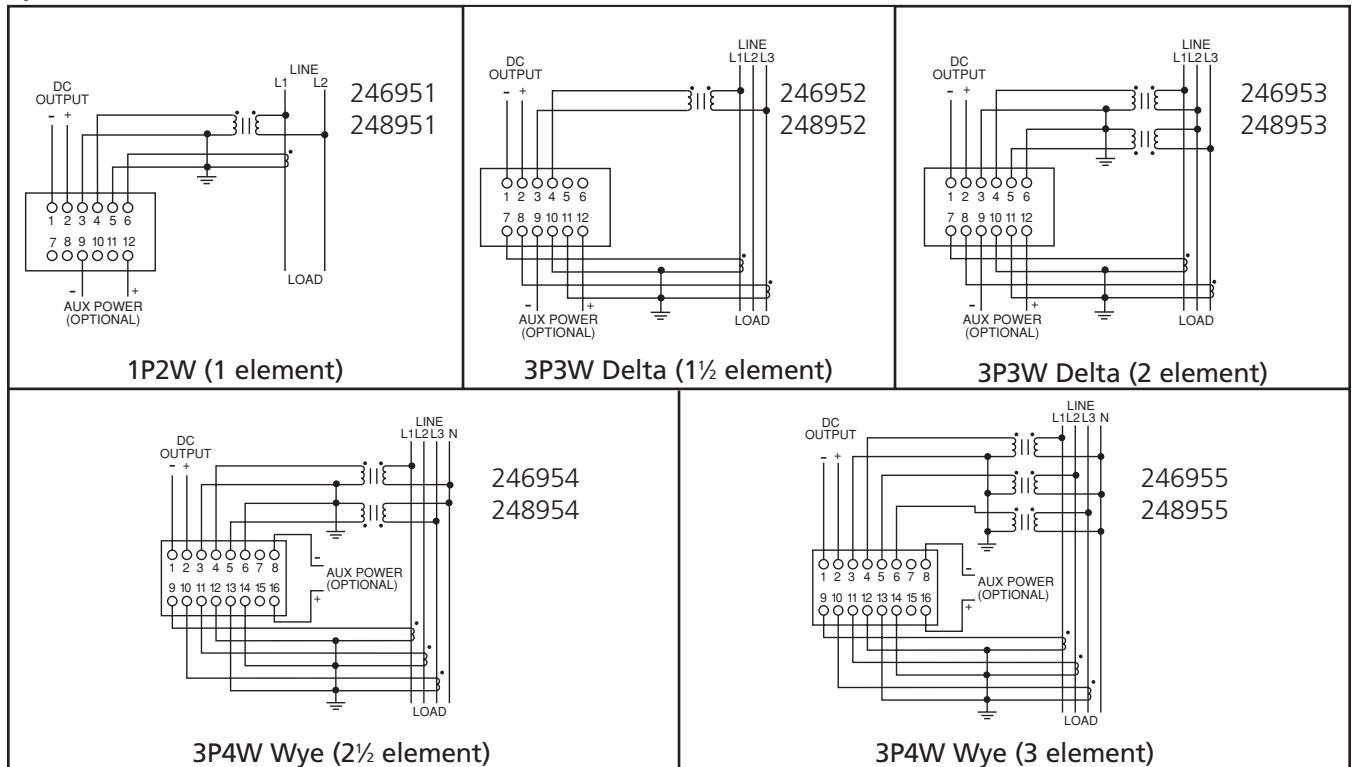

6) MOUNTING AND OUTLINE DIMENSIONS: (mm) inches

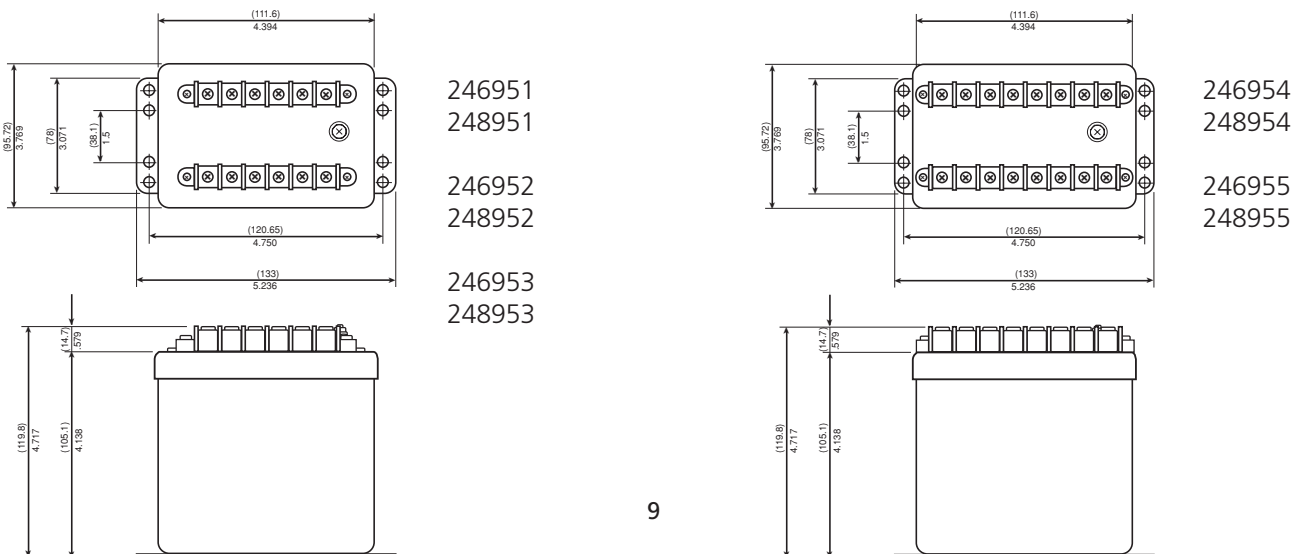

J U X T A A C V A R T R A N S D U C E R S

1) GENERAL

The 2469 and 2489 AC VAR transducers produce an analog output equal to the VARS measured by the input. The typical calibration is 500 VARS / element for 120V and 5A AC transformer secondary inputs.

2) SPECIFICATIONS

Model #	2469	2489
Current input / range	0-1 Amp AC or 0-5 Amp AC 10 to 200% of rated input	
Current input over range capability	200% of rated input continuous 1000% of rated input for 5 seconds	
Current input burden	< 0.2VA per element	
Voltage inputs and range: Input powered range Auxiliary powered range	120V 100-135VAC 0-120% rated input	240V 200-264VAC 0-120% of rated input
Voltage input burden per element	< 0.5VA < 1.0VA	< 0.3VA < 0.6VA
Sustained Voltage input overrange	150% of rated input without damage (Auxiliary powered only)	
Rated outputs	0 to ±1mADC into a 10kΩ max. load; 10VDC output compliance 12±8mADC into a 750Ω max. load; 15VDC output compliance	
Accuracy	0 ± 1mADC = ±0.5% of full scale 12±8mADC = ±0.5% of span	0±1mADC = ±0.1% rdg. ± 0.1%FS 12±8mADC = ±0.2% of span
Output calibration / element	120VAC: 1 Amp = 0-100 VARS; 5 Amp = 0-500 VARS 240VAC: 1 Amp = 0-200 VARS; 5 Amp = 0-1000 VARS	
External calibration adjustment	Zero: ± 1% minimum Span: ± 2% minimum	Zero: ± 5% minimum Span: ± 10% minimum
Response time	< 400 milliseconds (0-99% of output)	
Output ripple	0.3% of span peak-to-peak max.	0.5% of span peak-to-peak max.
Isolation	2500 VAC input to output, power and case 2000 VAC aux. power to output and case 500 VAC output to case	
Surge Withstand Capability	IEEE472/ANSI C37.90.1 - 1989, JIS C1111 (5KV 1.2 x 50 microseconds)	
Insulation resistance	> 10 megohm / 500VDC input/output/power/case	
Operating temperature	-20°C to +60°C	
Operating humidity	0 - 90% relative humidity (non-condensing)	
Temperature effect	±250 PPM / °C of span	1mA ±50FS, 4-20mA ±80span (PPM/°C)
External magnetic field	< 0.2% at 400 AT/m	
Influence : unbalanced currents / phase interaction / Power Factor	<0.5%	<0.2%
Weight	1200g (2.65 lbs.)	
Shock	<0.2% after 50G, 3 Axis and 6 repetitions	
Vibration	<0.2% after 16.7 Hz, 4 mmp-p 1 hour, 3 Axis	
UL Recognition	File # E60579	

3) STANDARD MODELS

120 VAC, 5AAC, 60 Hz, input powered	2469 (0.5% Accuracy)	2489 (0.2% Accuracy)
VAR 1P2W, ±1mA output (1 Element)	246961-540-AFB-0-M	248961-540-AFB-0-M
VAR 1P2W, 12±8mA output (1 Element)	246961-540-AHF-0-M	248961-540-AHF-0-M
VAR 3P3W, ±1mA output (2 Element)	246963-540-AFB-0-M	248963-540-AFB-0-M
VAR 3P3W, 12±8mA output (2 Element)	246963-540-AHF-0-M	248963-540-AHF-0-M
VAR 3P4W, ±1mA output (2½ Element)	246964-540-AFB-0-M	248964-540-AFB-0-M
VAR 3P4W, 12±8mA output (2½ Element)	246964-540-AHF-0-M	248964-540-AHF-0-M
VAR 3P4W, ±1mA output (3 Element)	246965-540-AFB-0-M	248965-540-AFB-0-M
VAR 3P4W, 12±8mA output (3 Element)	246965-540-AHF-0-M	248965-540-AHF-0-M

NOTE: See order format on next page for additional ratings, frequency calibrations, power-up and output options.
Auxiliary power supply options <5.0 VA burden.

JUXTA AC VAR TRANSDUCERS

4) ORDER FORMAT 2469 / 89 (1) - (2) (3) - (4) - (5) - (6)

Model#	(1) Transducer function	(2) Input	(3) Frequency	(4) Output	(5) Aux. power**	(6) Input/output relationship
2469	61 VAR 1P2W (1 Element)	53 120V/1AAC	0 60 Hz	AFB ±1 mADC	0 Input powered	M LAG=+POL.
2489	62 VAR 3P3W (1½ Element)*	54 120V/5AAC	1 50 Hz	AHF 12 ±8mADC	1 120 VAC	P LEAD=+POL.
	63 VAR 3P3W (2 Element)	57 240V/1AAC	4 400 Hz		2 240 VAC	
	64 VAR 3P4W (2½ Element)	58 240V/5AAC	5 Other			
	65 VAR 3P4W (3 Element)					

*Not UL

**Contact Factory For Other Power Supply Options

5) CONNECTION DIAGRAMS WITH PT AND CT INPUTS

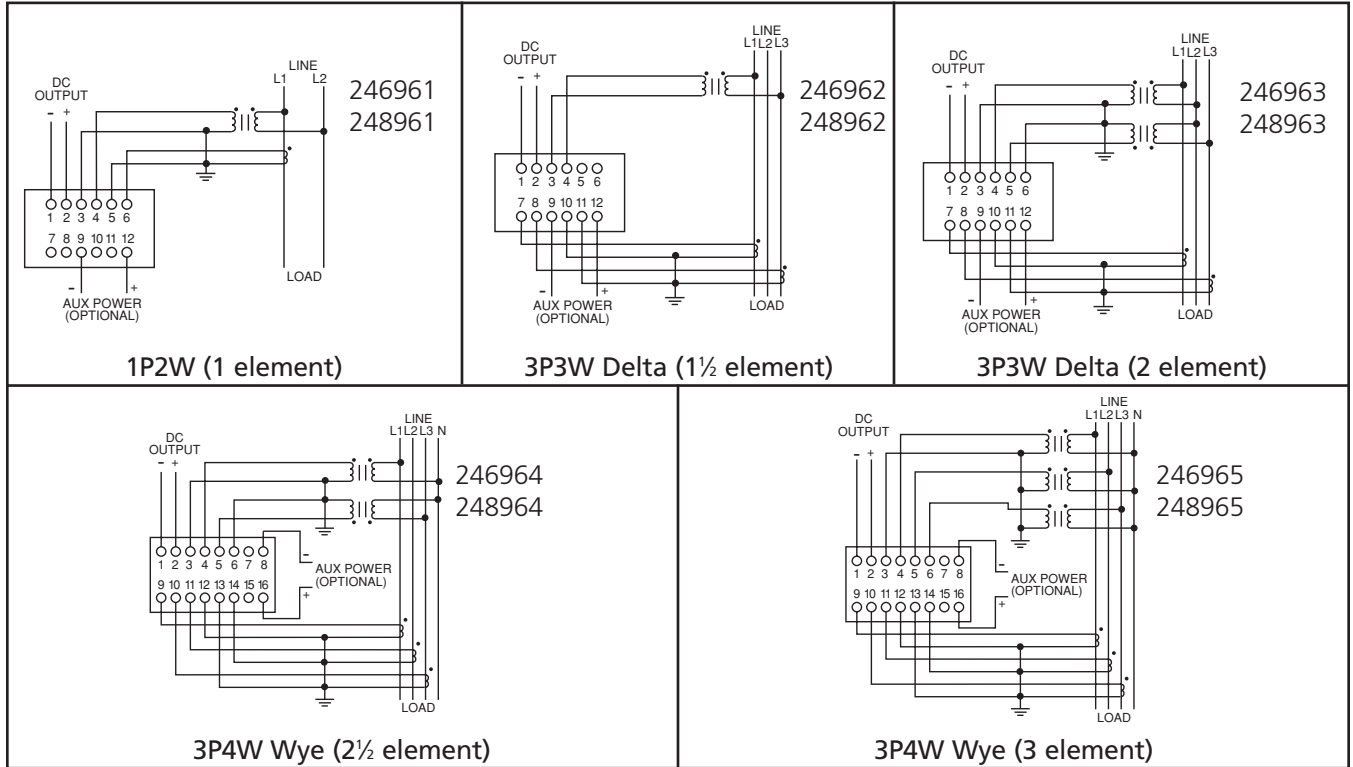

6) MOUNTING AND OUTLINE DIMENSIONS: (mm) inches

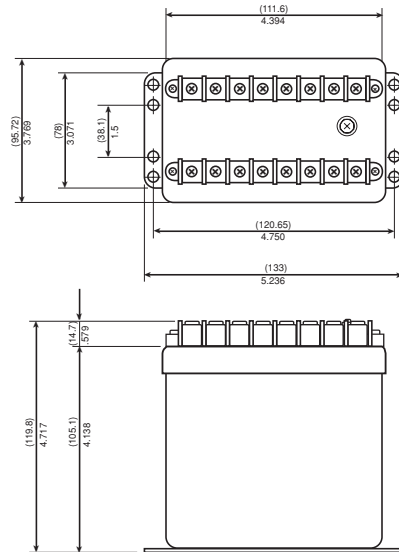
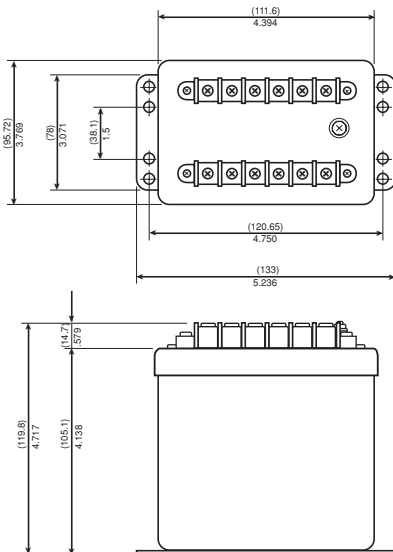

JUXTA COMBINATION WATT/VAR TRANSDUCERS

1) GENERAL

The 2469 and 2489 combined WATT/VAR transducers produce an analog output equal to the WATTS and VARS measured by the input.

2) SPECIFICATIONS

Model #	2469	2489
Current input / range	0-1 Amp AC or 0-5 Amp AC 10 to 200% of rated input	
Current input over range capability	200% of rated input continuous 1000% of rated input for 5 seconds	
Current input burden	< 0.2VA per element	
Voltage inputs and range: Input powered range Auxiliary powered range	120V 100-135VAC 0-120% rated input < 0.5VA	240V 200-264VAC 0-120% of rated input < 1.0VA
Voltage input burden per element	< 0.3VA	< 0.6VA
Sustained Voltage input overrange	150% of rated input without damage (Auxiliary powered only)	
Rated outputs	0 to ±1mADC into a 10kΩ max. load; 10VDC output compliance 4-20 mADC into 750Ω max. load; 15VDC output compliance	
Accuracy: 0 ± 1mA output Watts 0 ± 1mA output VARS 4-20mA output	±0.5% of full scale ±0.5% of full scale ±0.5% of span	± 0.1% of reading. ± 0.05% full scale ± 0.1% of reading. ± 0.1% full scale ± 0.2% of span
External calibration adjustment	Zero: ± 1% minimum Span: ± 2% minimum	Zero: ± 5% minimum Span: ± 10% minimum
Response time	< 400 milliseconds (0-99% of output)	
Output ripple	0.3% of span peak-to-peak max.	0.5% of span peak-to-peak max.
Isolation (Watt & VAR outputs are not isolated from each other)	2500 VAC input to output, power and case 2000 VAC aux. power to output and case 500 VAC output to case	
Surge Withstand Capability	IEEE472/ANSI C37.90.1 - 1989, JIS C1111 (5KV 1.2 x 50 microseconds)	
Insulation resistance	> 10 megohm / 500VDC input/output/power/case	
Operating temperature	-20°C to +60°C	
Operating humidity	0 - 90% relative humidity (non-condensing)	
Temperature effect	±250 PPM / °C of span	1mA = W ± 50FS, V ± 75span (PPM/°C)
External magnetic field	< 0.2% at 400 AT/m	
Influence : unbalanced currents / phase interaction / Power Factor	<0.5%	<0.2%
Influence of frequency	<0.25%, 45-65 Hz, fundamental through 9th harmonic (Watt only)	
Weight	1200g (2.65 lbs.)	
Shock	<0.2% after 50G, 3 Axis and 6 repetitions	
Vibration	<0.2% after 16.7 Hz, 4 mmp-p 1 hour, 3 Axis	
UL Recognition	File # E60579	

3) STANDARD MODELS

120 VAC, 5AAC, 60 Hz, input powered	2469 (0.5% Accuracy)	2489 (0.2% Accuracy)
W/V 1P2W, 0±1mA output (1 Element)	246941-540-AFB-0-M	248941-540-AFB-0-M
W/V 1P2W, 4-20mA output (1 Element)*	246941-540-AHD-0-M	248941-540-AHD-0-M
W/V 3P3W, 0±1mA output (2 Element)	246943-540-AFB-0-M	248943-540-AFB-0-M
W/V 3P3W, 4-20mA output (2 Element)*	246943-540-AHD-0-M	248943-540-AHD-0-M
W/V 3P4W, 0±1mA output (2½ Element)	246944-540-AFB-0-M	248944-540-AFB-0-M
W/V 3P4W, 4-20mA output (2½ Element)*	246944-540-AHD-0-M	248944-540-AHD-0-M
W/V 3P4W, 0±1mA output (3 Element)	246945-540-AFB-0-M	248945-540-AFB-0-M
W/V 3P4W, 4-20mA output (3 Element)*	246945-540-AHD-0-M	248945-540-AHD-0-M

NOTE: See order format on next page for additional ratings, frequency calibrations, power-up and output options.

*VAR outputs for "AHD" are 12±8 mADC (see output options on next page).

Auxiliary power supply options <5.0 burden.

JUXTA COMBINATION WATT/VAR TRANSDUCERS

4) ORDER FORMAT 2469 / 89 - - - -

Model#	(1) Transducer function	(2) Input	(3) Frequency	(4) Output	(5) Aux. power	(6) Input/output relationship
2469	41 W/V 1P2W (1 Element)	53 120V/1AAC	0 60 Hz	AFB W=±1mADC V=±1mADC	0 Input powered	M LAG=+POL.
2489	42 W/V 3P3W (1½ Element)*	54 120V/5AAC	1 50 Hz	AHD W=4-20mADC V=12±8mADC	1 120 VAC	P LEAD=+POL.
	43 W/V 3P3W (2 Element)	57 240V/1AAC	4 400 Hz	AHF W=12±8mADC V=12±8mADC	2 240 VAC	
	44 W/V 3P4W (2½ Element)	58 240V/5AAC	5 Other			
	45 W/V 3P4W (3 Element)					

*Not UL

5) CONNECTION DIAGRAMS WITH PT AND CT INPUTS

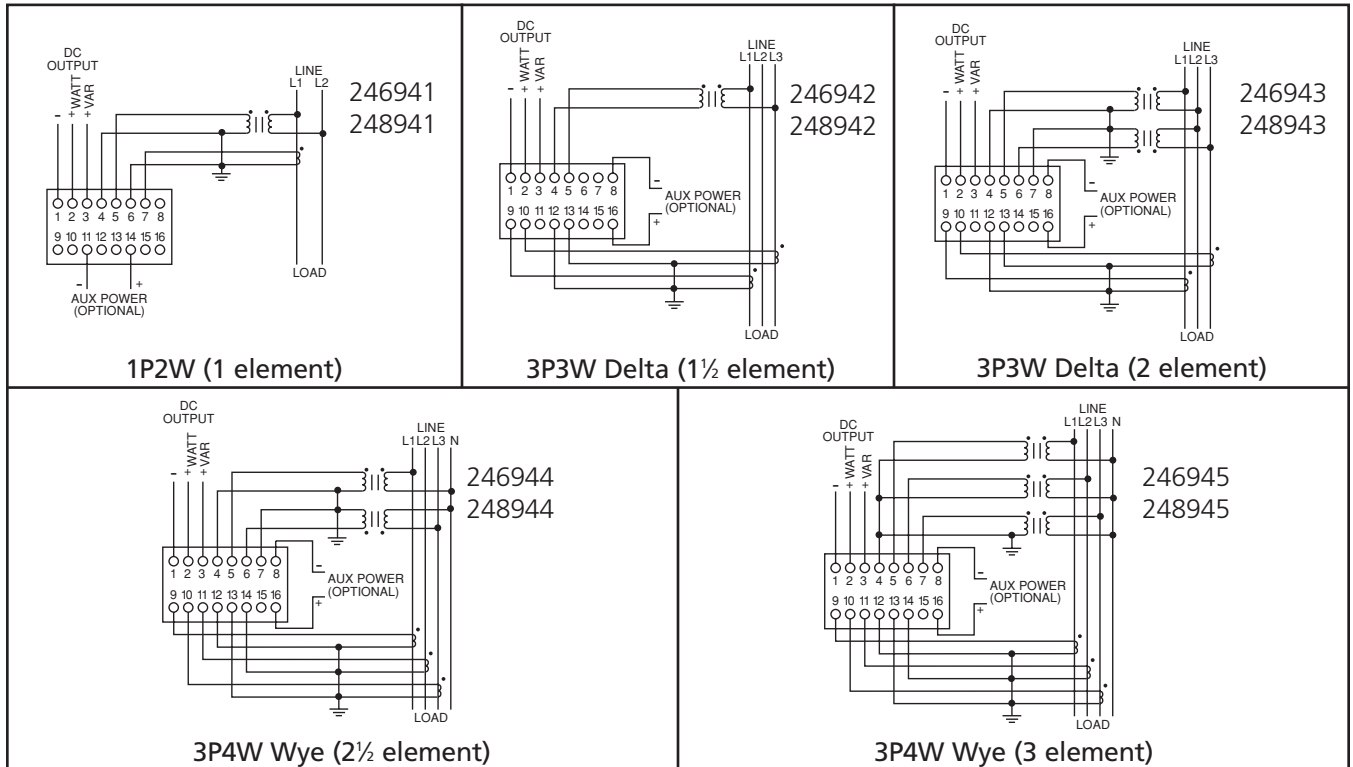

6) MOUNTING AND OUTLINE DIMENSIONS: (mm) inches

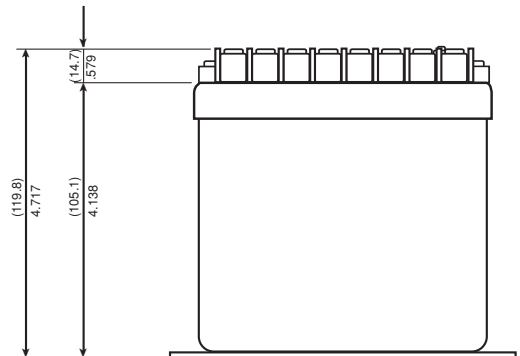
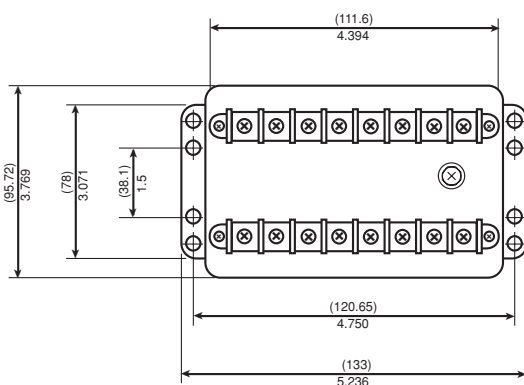

JUXTA POWER FACTOR TRANSDUCERS

1) GENERAL

The 2469 and 2489 Power Factor transducers have an analog output corresponding to 1- Cosine of the phase angle of the input current relative to the input voltage signal. The analog output will indicate leading or lagging Power Factor by its direction from center which would be either 0 mA or 12mA based on output selection.

2) SPECIFICATIONS

Model #	2469	2489
Current input / range	0-1 Amp AC or 0-5 Amp AC 10 to 200% of rated input	
Current input over range capability	200% of rated input continuous 1000% of rated input for 5 seconds	
Current input burden	< 0.2VA per element	
Voltage inputs and range: Input powered range Auxiliary powered range	120V 100-135VAC 0-120% rated input	240V 200-264VAC 0-120% of rated input
Voltage input burden per element	< 0.5VA	< 1.0VA
Sustained Voltage input overrange	150% of rated input without damage (Auxiliary powered only)	
Rated outputs	±1mADC into a 10kΩ max. load; 10VDC output compliance 4-12-20 mADC into a 750Ω max. load; 15VDC output compliance	
Accuracy	±0.01 Power Factor	
Output calibration	0-1-0 Power Factor or 0.5-1-0.5 Power Factor	
External calibration adjustment	Zero: ± 1% minimum Span: ± 2% minimum	Zero: ± 5% minimum Span: ± 10% minimum
Response time	< 400 milliseconds (0-99% of output)	
Output ripple	0.3% of FS peak-to-peak max.	0.5% of FS peak-to-peak max.
Isolation	2500 VAC input to output, power and case 2000 VAC aux. power to output and case 500 VAC output to case	
Surge Withstand Capability	IEEE472/ANSI C37.90.1 - 1989, JIS C1111 (5KV 1.2 x 50 microseconds)	
Insulation resistance	> 10 megohm / 500VDC input/output/power/case	
Operating temperature	-20°C to +60°C	
Operating humidity	0 - 90% relative humidity (non-condensing)	
Temperature effect	±500 PPM / °C of span	±150 PPM / °C of span
External magnetic field	< 0.2% at 400 AT/m	
Influence of input Voltage	<1% of span	Aux. Pwr.±0.01 max.±20% rated V. Self pwr.±0.01 max. in range of Aux. Pwr
Influence of input Current	<2% of span	<0.02 PF for 20-200% rated input current
Low current detection	<4% of rated current	4% of rated input
Weight	1000g (2.2 lbs.)	
Shock	<0.2% after 50G, 3 Axis and 6 repetitions	
Vibration	<0.2% after 16.7 Hz, 4 mmp-p 1 hour, 3 Axis	
UL Recognition	File # E60579	

3) STANDARD MODELS (0-1-0 PF)

120 VAC, 5AAC, 60 Hz, input powered	2469	2489
PF- Single phase / ±1mA output	246971-540-AFB-0-P	248971-540-AFB-0-P
PF- Single phase / 12±8mA output	246971-540-AHF-0-P	248971-540-AHF-0-P
PF- 3P3W balanced / ±1mA output	246973-540-AFB-0-P	248973-540-AFB-0-P
PF- 3P3W balanced / 12±8mA output	246973-540-AHF-0-P	248973-540-AHF-0-P
PF- 3P4W balanced / ±1mA output	246974-540-AFB-0-P	248974-540-AFB-0-P
PF- 3P4W balanced / 12±8mA output	246974-540-AHF-0-P	248974-540-AHF-0-P

NOTE: See order format on next page for additional ratings, frequency calibrations, power-up and output options.
Auxiliary power supply options <5.0 VA burden. 14

JUXTA POWER FACTOR TRANSDUCERS

4) ORDER FORMAT 2469 / 89 - - - -

Model#	(1) Transducer function	(2) Input	(3) Frequency	(4) Output	(5) Aux. power	(6) Input/output relationship
2469	71 PF-Single Phase	53 120V/1A;0-1-0 PF	0 60 Hz	AFB ±1 mADC	0 Input powered	M LAG=+POL.
2489	73 PF-3P3W balanced	54 120V/5A;0-1-0 PF	1 50 Hz	AHF 12 ±8mADC	1 120 VAC	P LEAD=+POL.
	74 PF-3P4W balanced	57 240V/1A;0-1-0 PF	4 400 Hz	5 Other	2 240 VAC	
		58 240V/5A;0-1-0 PF				
		63 120V/1A;5-1-5 PF				
		64 120V/5A;5-1-5 PF				
		67 240V/1A;5-1-5 PF				
		68 240V/5A;5-1-5 PF				

5) CONNECTION DIAGRAMS WITH PT AND CT INPUTS

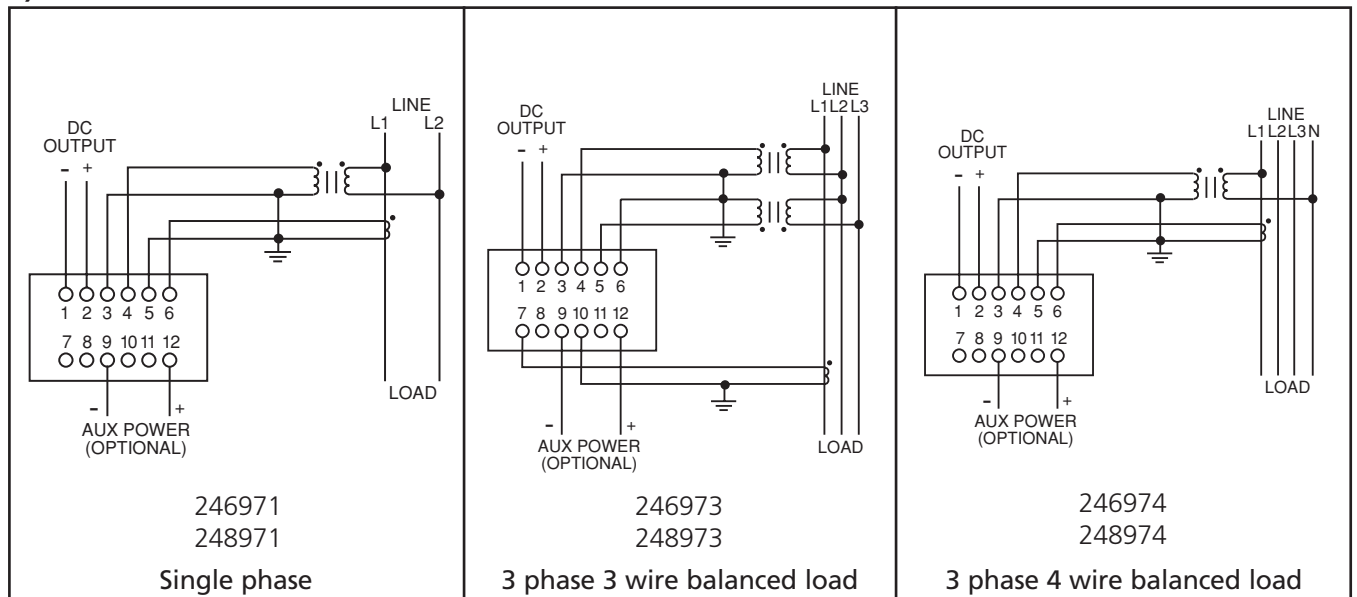

6) MOUNTING AND OUTLINE DIMENSIONS: (mm) inches

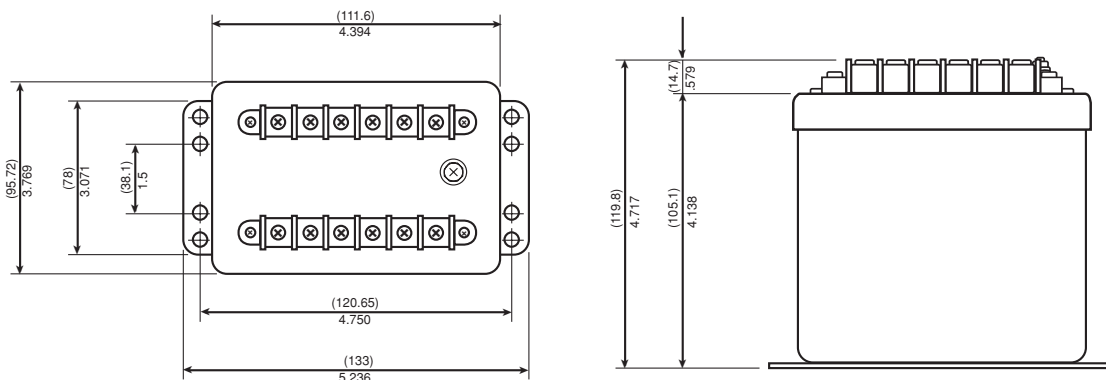

JUXTA PHASE ANGLE TRANSDUCERS

1) GENERAL

The 2469 and 2489 Phase Angle transducers have an analog output corresponding to the phase angle of the input current relative to the input voltage signal. The analog output will indicate leading or lagging Phase Angle by its direction from center which would be either 0 mA or 12mA based on output selection.

2) SPECIFICATIONS

Model #	2469	2489
Current input / range	0-1 Amp AC or 0-5 Amp AC 10 to 200% of rated input	
Current input over range capability	200% of rated input continuous 1000% of rated input for 5 seconds	
Current input burden	< 0.2VA per element	
Voltage inputs and range: Input powered range Auxiliary powered range	120V 100-135VAC 0-120% rated input	240V 200-264VAC 0-120% of rated input
Voltage input burden per element	< 0.5VA	< 1.0VA
Sustained Voltage input overrange	150% of rated input without damage (Auxiliary powered only)	
Rated outputs	±1mADC into a 10kΩ max. load; 10VDC output compliance 4-12-20 mADC into a 750Ω max. load; 15VDC output compliance	
Accuracy	±2° Phase Angle	±1° Phase Angle
Output calibration	60°- 0°- 60° Phase Angle or 90°- 0°- 90° Phase Angle	
External calibration adjustment	Zero: ± 1% minimum Span: ± 2% minimum	Zero: ± 5% minimum Span: ± 10% minimum
Response time	< 400 milliseconds (0-99% of output)	
Output ripple	0.3% of FS peak-to-peak max.	0.5% of FS peak-to-peak max.
Isolation	2500 VAC input to output, power and case 2000 VAC aux. power to output and case 500 VAC output to case	
Surge Withstand Capability	IEEE472/ANSI C37.90.1 - 1989, JIS C1111 (5KV 1.2 x 50 microseconds)	
Insulation resistance	> 10 megohm / 500VDC input/output/power/case	
Operating temperature	-20°C to +60°C	
Operating humidity	0 - 90% relative humidity (non-condensing)	
Temperature effect	±500 PPM / °C of span	±80 PPM / °C of span
External magnetic field	< 0.2% at 400 AT/m	
Influence of frequency	<0.2%, 45 - 65 Hz, fundamental through 9th harmonic	
Influence of input Voltage	<0.5°	<0.5° ±20% rated Voltage input (aux.pwr.) <0.5° in range af aux. pwr. (int. pwr. model)
Influence of input Current	<1.0°	<1° for 20-200% rated input current
Low current detection	N/A	4% of rated input
Weight	1000g (2.2 lbs.)	
Shock	<1° after 50G, 3 Axis and 6 repetitions	
Vibration	<1° after 16.7 Hz, 4 mmp-p 1 hour, 3 Axis	
UL Recognition	File # E60579	

3) STANDARD MODELS (±90° PA)

120V, 5A, 60 Hz, ±90°, input powered	2469 (±2° Accuracy)	2489 (±1° Accuracy)
PA- Single phase / ±1mA output	246976-540-AFB-0-P	248976-540-AFB-0-P
PA- Single phase / 12±8mA output	246976-540-AHF-0-P	248976-540-AHF-0-P
PA- 3P3W balanced / ±1mA output	246977-540-AFB-0-P	248977-540-AFB-0-P
PA- 3P3W balanced / 12±8mA output	246977-540-AHF-0-P	248977-540-AHF-0-P
PA- 3P4W balanced / ±1mA output	246978-540-AFB-0-P	248978-540-AFB-0-P
PA- 3P4W balanced / 12±8mA output	246978-540-AHF-0-P	248978-540-AHF-0-P

NOTE: See order format on next page for additional ratings, frequency calibrations, power-up and output options.
Auxiliary power supply options <5.0 VA burden.

JUXTA PHASE ANGLE TRANSDUCERS

4) ORDER FORMAT 2469 / 89 (1) (2) (3) (4) (5) (6)
 - - - - -

Model#	(1) Transducer function	(2) Input	(3) Frequency	(4) Output	(5) Aux. power	(6) Input/output relationship
2469	76 PA-Single Phase	53 120V/1AAC; ±90°	0 60 Hz	AFB ±1 mADC	0 Input powered	M LAG=+POL.
2489	77 PA-3P3W balanced	54 120V/5AAC; ±90°	1 50 Hz	AHF 12 ±8mADC	1 120 VAC	P LEAD=+POL.
	78 PA-3P4W balanced	57 240V/1AAC; ±90°	2 50/60 Hz			
		58 240V/5AAC; ±90°	4 400 Hz		2 240 VAC	
		63 120V/1AAC; ±60°	5 Other			
		64 120V/5AAC; ±60°				
		67 240V/1AAC; ±60°				
		68 240V/5AAC; ±60°				

5) CONNECTION DIAGRAMS WITH PT AND CT INPUTS

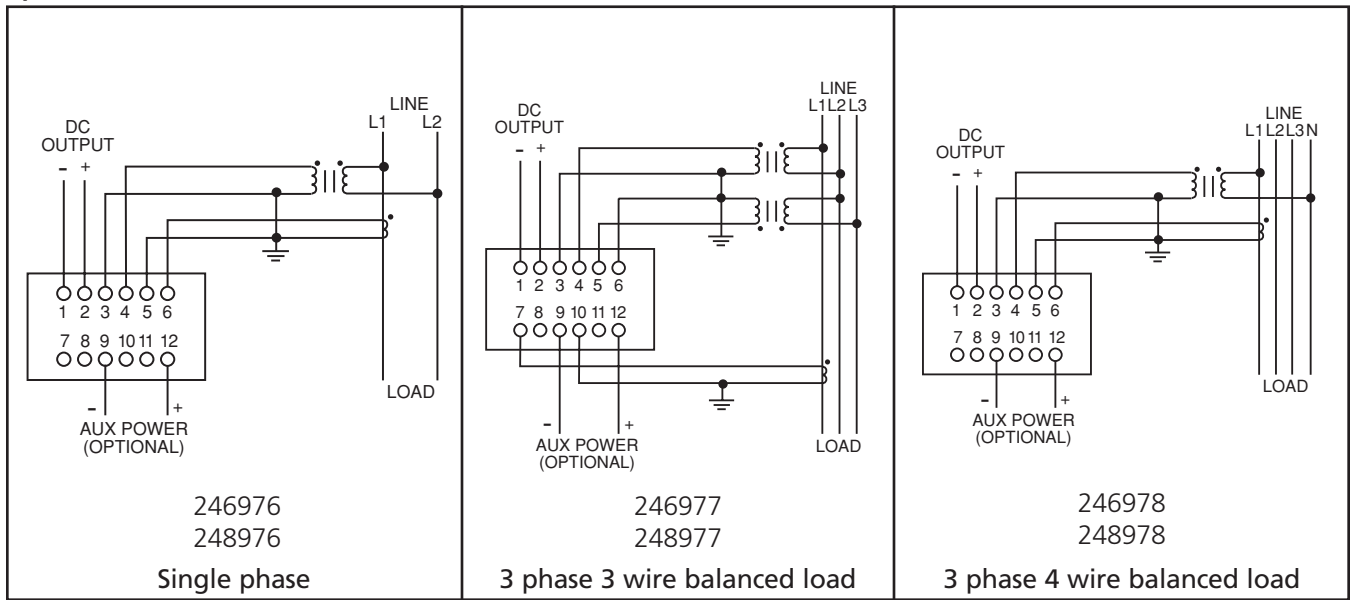

6) MOUNTING AND OUTLINE DIMENSIONS: (mm) inches

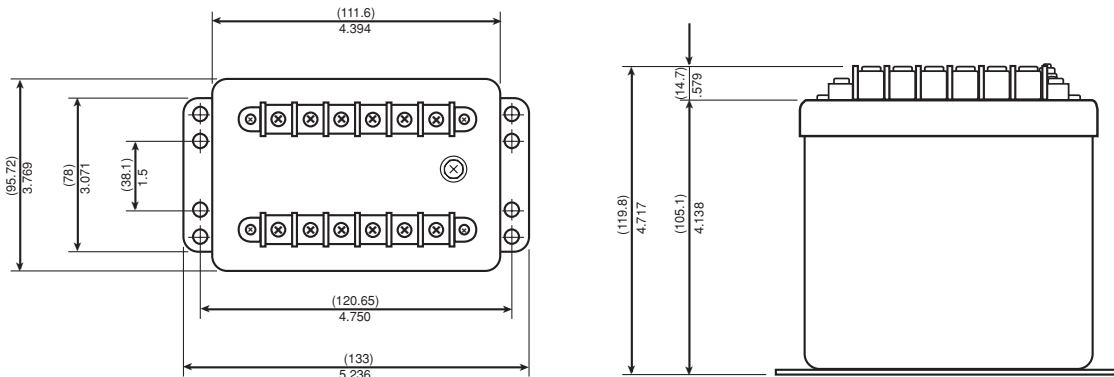

JUXTA FREQUENCY TRANSDUCERS

1) GENERAL

The 2469 and 2489 Frequency transducers have an analog output corresponding to the frequency of the AC input voltage. These transducers are capable of high accuracy measurement over various frequency ranges.

2) SPECIFICATIONS

Model #	2469	2489
Voltage inputs and range: Input powered range Auxiliary powered range	120V: 100 - 135 VAC, 240V: 200 - 264 VAC ±20% of rated voltage	
Voltage input burden	120VAC <0.1 VA; 240VAC <0.2 VA	
Rated outputs	±1mADC into a 10kΩmax. load; 10VDC output compliance 4-12-20 mADC into 750Ω max. load; 15VDC output compliance	
Accuracy: ±2, 5, 10, 25 Hz deviation ±0.5, 1 Hz deviation	±1% of input span ±2% of input span	0-1mADC=±0.1% of input span 0-1mADC=±0.2% of input span 4-20mADC=add±0.1% to accuracy
External calibration adjustment	Zero: ±1% minimum Span: ±2% minimum	Zero: ±5% minimum Span: ±10% minimum
Response time	<400 milliseconds (0-99% of output)	
Output ripple	0.3% of span peak-to-peak max.	0.5% of span peak-to-peak max.
Isolation	2500 VAC input to output, power and case 2000 VAC aux. power to output and case 500 VAC output to case	
Surge Withstand Capability	IEEE472/ANSI C37.90.1 - 1989, JIS C1111(5KV 1.2 x 50 microseconds)	
Insulation resistance	>10 megohm / 500VDC input/output/power/case	
Operating temperature	-20°C to +60°C	
Operating humidity	0 - 90% relative humidity (non-condensing)	
Temp. effect: ±2, 5, 10, 25 Hz deviation ±0.5, 1 Hz deviation	± 250 PPM / °C of span ± 500 PPM / °C of span	±25ppm of center frequency(60Hz±5Hz) ±5ppm of center frequency(60Hz±0.5Hz) For 4-20mADC multiply ppm x 1.4
External magnetic field	< 0.2% at 400 AT/m	
Harmonics	Fundamental through 9th harmonic	
Weight	1000g (2.2 lbs.)	
Shock	< 0.2% after 50G, 3 Axis and 6 repetitions	
Vibration	< 0.2% after 16.7 Hz, 4 mmp-p 1 hour, 3Axis	
UL Recognition	File # E60579	

3) STANDARD MODELS

120VAC, 60 Hz, input powered	2469	2489
Freq. ± 1.0 Hz deviation, 0-1mA output	246982-320-AFA-0	248982-320-AFA-0
Freq. ± 1.0 Hz deviation, 4-20mA output	246982-320-AHD-0	248982-320-AHD-0
Freq. ± 2.0 Hz deviation, 0-1mA output	246983-320-AFA-0	248983-320-AFA-0
Freq. ± 2.0 Hz deviation, 4-20mA output	246983-320-AHD-0	248983-320-AHD-0
Freq. ± 5.0 Hz deviation, 0-1mA output	246984-320-AFA-0	248984-320-AFA-0
Freq. ± 5.0 Hz deviation, 4-20mA output	246984-320-AHD-0	248984-320-AHD-0

NOTE: See order format on next page for additional ratings, frequency calibrations, power-up and output options.
Auxiliary power supply options <5.0 VA burden.

JUXTA FREQUENCY TRANSDUCERS

4) ORDER FORMAT 2469 / 89 - - -

Model#	(1) Transducer function	(2) Input	(3) Input frequency	(4) Output	(5) Aux. power
2469	81 ± 0.5 Hz deviation	32 120 VAC	0 60 Hz	AFA 0-1 mADC	0 Input pwr'd
2489	82 ± 1 Hz deviation	35 240 VAC	1 50 Hz	AFB 0 to ±1mADC	1 120 VAC
	83 ± 2 Hz deviation	35 240 VAC		AHD 4-20 mADC	2 240 VAC
	84 ± 5 Hz deviation	32 120 VAC		35 240 VAC	
	84 ± 5 Hz deviation	32 120 VAC	3 55 Hz		
	85 ± 10 Hz deviation	35 240 VAC	4 400 Hz		
	86 ± 25 Hz deviation	32 120 VAC			
		35 240 VAC			

5) CONNECTION DIAGRAMS

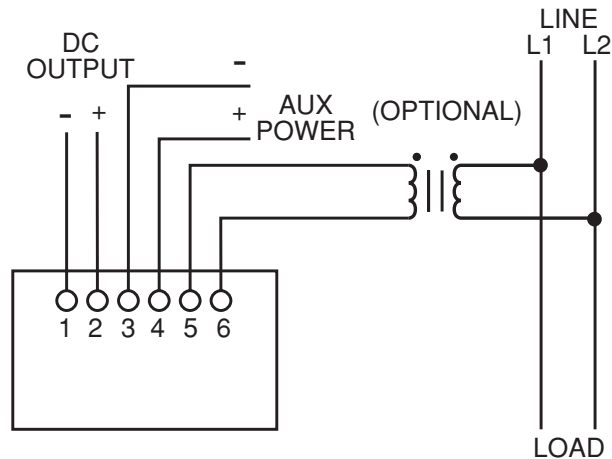

6) MOUNTING AND OUTLINE DIMENSIONS: (mm) inches

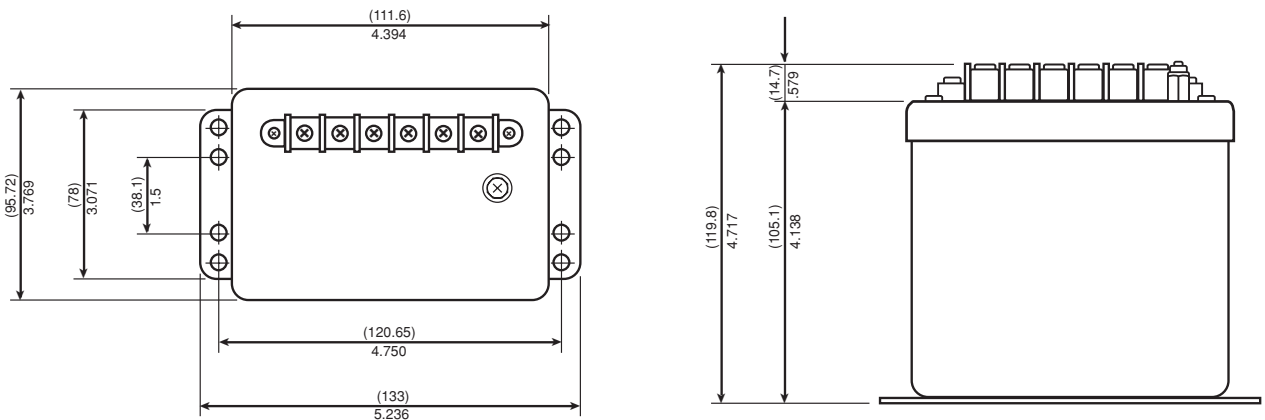

ACCURACY

Yokogawa 2489 series transducers are designed for reliable and repeatable operation over a wide range of conditions at the highest attainable accuracy. Recently, we performed a series of tests on our transducers in a Thermotron test chamber with a Rotek 800AE calibrator, Yokogawa 2558 AC standard and 7562 digital multi-meter. We plotted outputs at various inputs, temperatures, and power factors. These charts are a sampling of data from these tests and consistently demonstrate a high level of accuracy and performance over the full range of conditions. A base line of 1mA is the expected output at full scale input of the transducers under test.

CHART 1

All tests plots are within specified accuracy of $\pm 0.15\%$ (0.1% reading + 0.05% full scale) with 1000 Watt and 1.0 power factor input over the temperature range of -20°C to $+60^{\circ}\text{C}$. Test data at inputs of 250, 500, 750 watts are also consistent with this chart representation. Test data at other power factors are also within specification for power factor influence.

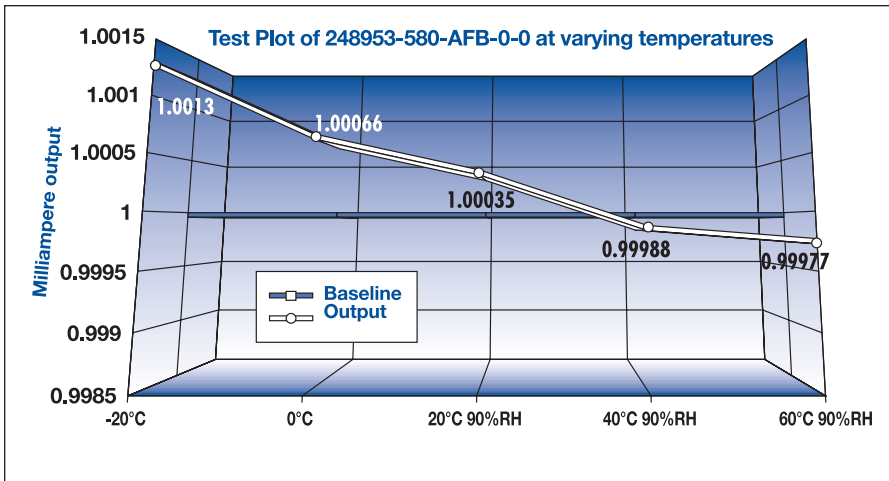

ACTUAL TEST DATA

OUTPUT	TEMPERATURE
1.0013	-20°C
1.00066	0°C
1.00035	20°C 90%R/H
0.99988	40°C 90%R/H
0.99977	60°C 90%R/H

CHART 2

All tests plots are within specified accuracy of $\pm 0.2\%$ of full scale with 5 Amp AC input over the temperature range of -20°C to $+60^{\circ}\text{C}$. Test data at other inputs such as .5, 1, 2, 2.5, 3, 4, Amp are also consistent with this chart representation.

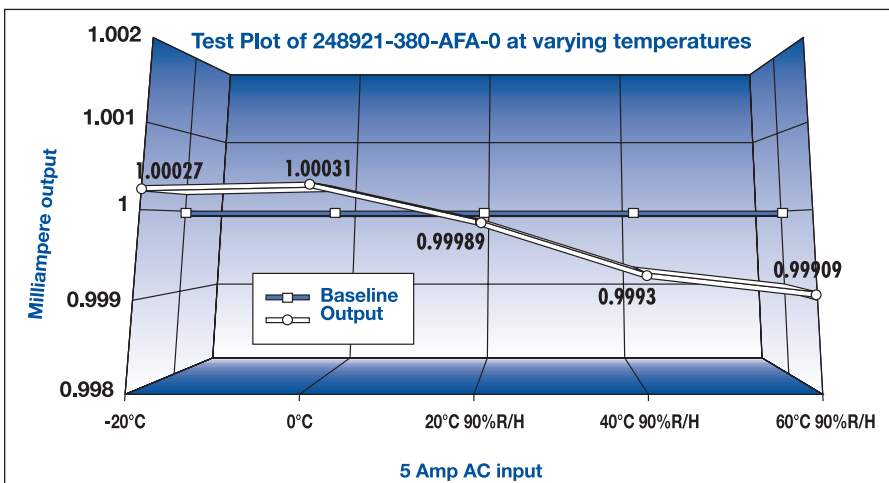

ACTUAL TEST DATA

OUTPUT	TEMPERATURE
1.00027	-20°C
1.00031	0°C
0.99989	20°C 90%R/H
0.99993	40°C 90%R/H
0.99909	60°C 90%R/H

SELECTING A WATT OR VAR TRANSDUCER

1) CIRCUIT CONFIGURATIONS AND TYPICAL POWER MEASUREMENT APPLICATIONS

Circuit configuration		Common Power Distribution systems	Typical load / restrictions
1P2W	1 Element	120/240V	Household appliance & lighting
1P3W	1½ Element	120/240V	Residential / balanced voltage
3P3W	2 Element	240 and 480V line-to-line (Delta connected)	Substation & industrial motors
3P4W	2½ Element	120/208 and 277/480V (Wye connected)	Ind'l. & Comm'l. / balanced voltage
3P4W	3 Element	120/208 and 277/480V (Wye connected)	Ind'l. & Comm'l. / unbalanced volt.

NOTE: With a 3P4W load, Transducer connections are line-to-neutral.

2) STANDARD WATT / VAR CALIBRATION RANGES

	Rating		Standard calibrating watt ranges available				
	Volt	Amp	1 Element	1½ Element	2 Element	2½ Element	3 Element
WATT	120V	1A	85 to 115 CW	170 to 230 CW	170 to 230 CW	255 to 345 CW	255 to 345 CW
	120V	5A	425 to 575 CW	850 to 1150 CW	850 to 1150 CW	1275 to 1725 CW	1275 to 1725 CW
	240V	1A	170 to 230 CW	340 to 460 CW	340 to 460 CW	510 to 690 CW	510 to 690 CW
	240V	5A	850 to 1150 CW	1700 to 2300 CW	1700 to 2300 CW	2550 to 3450 CW	2550 to 3450 CW
VAR	120V	1A	±85 to ±115 CW	±170 to ±230 CW	±170 to ±230 CW	±255 to ±345 CW	±255 to ±345 CW
	120V	5A	±425 to ±575 CW	±850 to ±1150 CW	±850 to ±1150 CW	±1275 to ±1725 CW	±1275 to ±1725 CW
	240V	1A	±170 to ±230 CW	±340 to ±460 CW	±340 to ±460 CW	±510 to ±690 CW	±510 to ±690 CW
	240V	5A	±850 to ±1150 CW	±1700 to ±2300 CW	±1700 to ±2300 CW	±2550 to ±3450 CW	±2550 to ±3450 CW

NOTE: Use formula below to determine if your application is within standard range. Specify CT/PT ratios and primary Watts/VARs relative to desired output. Non-standard ranges are available as an option.

3) DETERMINING CALIBRATING WATTS FOR A WATT OR VAR TRANSDUCER

When PT and CT secondary inputs are specified the calibrating watts can be determined as follows:

$$\text{Power transducer input (P)} = \text{Rated Value/PT ratio} \times \text{CT ratio} = \text{total calibrating Watts}$$

Example #1 - 3P3W, 2 element with 0-1mA output for 0-25KW input, PT= 480 : 120V, CT = 30 : 5A

$$P = \frac{25,000 \text{ Watts}}{(480/120) \times (30/5)} = 1041.67 \text{ calibrating watts (this is within standard CW range)}$$

Example #2 - 3P3W, 2 element with 4-20mA output for 0-20KW input, PT = 480 : 120V, CT = 30 : 5A

$$P = \frac{20,000 \text{ Watts}}{(480/120) \times (30/5)} = 833.33 \text{ calibrating watts (non-standard CW range and an option)}$$

4) INPUT/OUTPUT RELATIONSHIP USING EXAMPLE #1 AND #2 FROM ABOVE

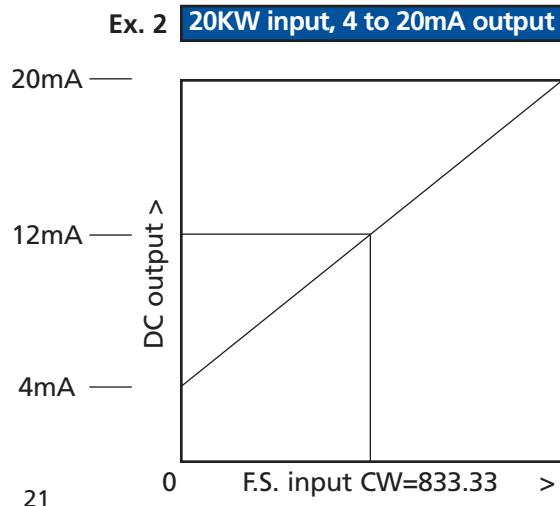
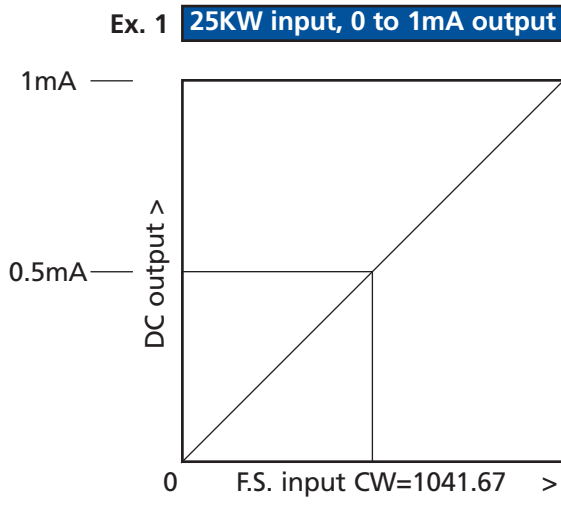

POWER TRANSDUCER TERMINOLOGY

Accuracy

The ratio of the error to a standard or true value and expressed as a percent.

Ampere

Unit of electrical current or rate of flow of electrons. One volt across one ohm of resistance causes one ampere of current flow

ANSI

American National Standards Institute.

Auxiliary Power

The power supplied from an external power source for correct operation of a transducer. (Also see input powered.)

Balanced load

An AC polyphase system where all phase-to-phase voltages, phase currents, and power factors are identical.

Burden

Expressed in Volt-Amperes (VA), and represents the electrical load an instrument or transducer places on current or potential transformers. Exceeding a CT or PT rated burden affects accuracy.

Calibration

To make precision adjustments to a transducer so that the output is within a specific range for particular values of the input. High accuracy test equipment is used for verification.

Compliance voltage or Output Compliance

The maximum voltage that a transducer current output can supply and still maintain specified accuracy.

Current transformer

An instrument transformer connected in series with current-carrying conductors for the purpose of measurement and control. Typically, a CT will step down high current to a level that can be safely measured with an instrument or transducer.

Current transformer ratio (CT ratio ; CTR)

The ratio of primary amps divided by the secondary amps (example: 500A : 5A = 100 : 1).

Element

An electronic circuit in a Watt / Var / Power Factor transducer that accepts a voltage and a current input, then produces a proportionate analog signal. The number of elements required varies with circuit configuration; and, if a polyphase circuit, whether it is a balanced load.

Frequency

In electrical terms, it is the measure of complete cycles of a waveform per unit of time and specified as Hertz(Hz) or cycles per second.

Full scale output

The maximum output value for which the specified accuracy applies (ie, 0.2% accuracy @ 1mA full scale output).

Harmonic

A sinusoidal wave having a frequency that is an integral multiple of the fundamental frequency (Ex: 3rd harmonic of 60Hz fundamental is 180 Hz). Non-linear loads cause distorted waveforms which create higher harmonics and heating effect.

Impedance

The vector sum of resistance, inductive reactance and capacitive reactance.

Input

Input voltage and/or current are always specified by the transducer user. For Watt/Var/Power Factor/Phase Angle transducers, both voltage and current input must be specified. If CT's and/or PT's are used, then the primary and secondary ratings (or ratios) are required for proper calibration of Watts and VARS.

Input powered

This means the transducer is self-powered by the line being measured. (Also see auxiliary power.)

Insulation resistance

The ability of dielectric insulating materials to resist electrical leakage current when a voltage is applied. Usually specified at a DC voltage level and Megohm value.

Isolation

The electrical separation between various components in a transducer. The measure of strength of a dielectric system to electrically isolate is usually expressed with various test voltage levels such as 2500VAC, etc.

Lag or Lagging

The current flowing in a circuit lags the applied voltage. This condition indicates a mostly inductive load.

Lead or Leading

The current flowing in a circuit leads the applied voltage. This condition indicates a mostly capacitive load.

Neutral or neutral conductor

The common return path for current from the load to the source in AC circuits. Frequently connected to ground.

Ohm

One ohm is a unit of electrical resistance equal to that of a conductor in which a current of one ampere is produced by a potential of one volt across its terminals.

Output ripple

Expressed as percent of full scale or span and represents the magnitude of AC fluctuations in the DC output signal.

Overrange

The maximum input or output values above rated values.

Peak-to-Peak

Amplitude of an AC waveform from the positive to the negative peak value.

Phase

The number of separate voltage waves in an AC supply such as single phase or three phase.

Phase Angle

The angular difference in electrical degrees by which current leads voltage in a capacitive circuit or lags voltage in an inductive circuit.

Polyphase

More than one phase conductor: such as a 3 phase 3 wire power circuit (3P3W).

Potential Transformer (PT)

An instrument transformer with primary winding connected in parallel with the circuit to be measured. Used to step-up or step-down an AC voltage to a level that can be used for measurement or control purposes.

Potential Transformer ratio (PT ratio)

The ratio of primary voltage divided by the secondary voltage (ie, 14,400V : 120V = 120 : 1).

Power Factor

The Power Factor of any AC circuit is equal to the true power (watts) divided by the apparent power (volt-amperes) which is equal to the cosine of the phase angle in circuits with sinusoidal waveforms.

Reading

The expected output value at a given input value.

Response time

In transducer terms, the time required after an abrupt change in input value for the output signal to reach 99% of the new input. Response time is influenced by many factors and standardized test conditions should apply.

RMS

Abbreviation for root-mean-square. The value of AC current or voltage that will produce the same amount of heat in a pure resistance as the corresponding value of DC.

Sine wave or sinusoidal wave

An alternating signal where instantaneous values vary as the sine of the peak value over a complete cycle.

Span

The difference between the low and high limits of a range (ie, 4-20mA has a span of 16mA).

Surge Withstand Capability test (SWC)

An oscillatory test wave applied to a transducer by a generator to simulate transient voltage conditions that could be damaging to an unprotected component system.

Transducer

A device used for measurement purposes that accepts an electrical signal and outputs a low level DC signal that is proportionate to the input.

True RMS

The definition is the same as RMS, except that it is a more precise method of measuring non-sinusoidal waveforms.

VAR (Volt-Ampere-Reactive)

A unit of reactive power as opposed to real power in Watts. Measured in VARS, KiloVARS, MegaVARS.

Volt

A unit of electromotive force. One volt equals the force required to produce one ampere of current to flow through a resistance of one ohm.

Watt

A unit of real (effective) power measured in Watts, Kilowatts, Megawatts. Equals the product of Voltage, Current and Power Factor ($EI \times PF = \text{Watts}$) in a sinusoidal system.

Waveform

The graphic representation of the shape of an electromagnetic wave showing the variations in amplitude with time.

1) GENERAL

The 2371-2378 and 2461-2468 series of power transducers combine high performance with compact size. Most of these transducers are self powered except DC to DC isolators and True RMS Amps and Volts which require auxiliary power. Accuracy of 0.5% is standard in both the foot mount and DIN rail models. They are constructed of flame resistant molded black ABS resin material; and operating temperature is 0-40°C (20-80% RH, non-condensing). Storage temperature is -10 to +50°C. Weight <.5Kg (1.1lbs.)



2461-2468 DIN rail mount



2371-2378 foot mount

2) SPECIFICATIONS

Transducer function		Model#	code	Rated inputs	*Rated outputs/external load resistance	Accuracy @23±3°C	Output ripple	Response time	Frequency range	Power consump.	Auxiliary power
DC / DC Isolator (Photocoupler isolation)	2371 or 2461	00	00	0 - 50 mVDC 0 - 5 VDC 0 - 10VDC 0 - 25VDC 0 - 65VDC 0 - 1mADC	0 - 1mADC / 10kΩ 0 - 5mADC / 2kΩ 4 - 20mADC / 500Ω 0 - 10mVDC / 10kΩ 0 - 5VDC / 1kΩ 0 - 10VDC / 2kΩ	±0.5% of span	N / A	0.5 sec.	DC	~1mA + aux. pwr. 1.9VA	120VAC ±10%
			00	1 AAC	0 - 1mADC / 10kΩ 0 - 5mADC / 2kΩ	±0.5% of span	1% p-p max.	1 second	45-65 Hz	1 VA	not req'd
AC Voltage/Current (Mean value rect.)	2372 2462	00	5 AAC	0 - 5VDC / 5kΩ 0 - 1mADC / 2kΩ	±0.5% of span	1% p-p max.	0.5 sec.	45-10kHz	0.5 VA+ Aux. pwr. 2 VA	120VAC ±10%	not req'd
AC Voltage/Current (RMS value rect.)	2373 2463	00	150 VAC	0 - 10VDC / 2kΩ 0 - 1mADC / 10kΩ 4 - 20mADC / 500Ω	±0.5% of span	1% p-p max.	0.5 sec.	45-10kHz	0.5 VA+ Aux. pwr. 2 VA	120VAC ±10%	not req'd
AC Voltage/Current (True RMS rect.)	2374 or 2464	00	300 VAC	0 - 10VDC / 2kΩ 0 - 1mADC / 10kΩ 4 - 20mADC / 500Ω	±0.5% of span	1% p-p max.	0.5 sec.	45-10kHz	0.5 VA+ Aux. pwr. 2 VA	120VAC ±10%	not req'd
Power (Watts)	1P2W	2375 2465	10	120V / 1 AAC	0 - 10VDC / 2kΩ 0 - 1mADC / 10kΩ	±0.5% of span	1% p-p max.	0.7 sec.	45-65 Hz	V = 3VA A = 1VA	not req'd
	1P3W		20	120V / 5 AAC	0 - 1mADC / 10kΩ						
	3P3W		30	240V / 1 AAC	0 - 5mADC / 2kΩ						
	3P4W		40	240V / 5 AAC	4 - 20mADC / 500Ω						
Reactive Power (VARs)	1P2W	2376 2466	10	120V / 1 AAC	± 10 VDC / 2kΩ ± 1mADC / 10kΩ	±0.5% of span	1% p-p max.	0.5 sec.	45-65 Hz	V = 2.5VA A = 0.1VA	not req'd
	1P3W		20	120V / 5AAC	± 5mADC / 2kΩ						
	3P3W		30	240V / 1AAC	± 5mADC / 2kΩ						
	3P4W		40	240V / 5AAC	4 - 20mADC / 500Ω						
Phase Angle	1P2W	2377 2467	10	120V / 1AAC	± 10 VDC / 2kΩ ± 1mADC / 10kΩ	±2°	1% p-p max.	2 seconds	45-55 Hz	1.5VA	not req'd
	1P3W		20	120V / 5AAC	± 1mADC / 10kΩ						
	3P3W		30	240V / 1AAC	± 5mADC / 2kΩ						
	3P4W		40	240V / 5AAC	4 - 20mADC / 500Ω						
Frequency	2378 2468	01	120V/45-55Hz 240V/45-55Hz	0 - 10VDC / 2kΩ 0 - 1mADC / 10kΩ	±0.1 Hz	.1%p-p max.	2 seconds	45-55 Hz	1.5VA	not req'd	
		02	120V/55-65Hz 240V/55-65Hz	0 - 5mADC / 2kΩ	±0.2Hz			55-65 Hz			
		03	120V/45-65Hz 240V/45-65Hz	4 - 20mADC / 500Ω				45-65 Hz			

*See next page for additional outputs.

PLASTIC CASE MINIATURE TRANSDUCERS

3) GENERAL SPECIFICATIONS

Overrange capability	Dielectric strength between:	Insulation resistance between:
Current input: 1000% of rated input for 5 sec.	1) Input terminals & case - 2600VAC for 1 minute	1) All terminals and ground terminal
Voltage input: 150% of rated input for 5 sec.	2) Input & output terminals - 2600VAC for 1 minute	2) Input/output/ground term./auxiliary pwr.
	3) Aux. pwr. term. & input term./case-2600VAC for 1 min.	-----
	4) Output terminals and case - 1000VAC for 1 minute	Is greater than 100 Megohm at 500VDC

4) STANDARD MODELS (AC AMPS, VOLTS, WATTS, VARS, PHASE ANGLE)

Input	Output	DIN Rail	Foot Mount	Input	Output	DIN Rail	Foot Mount
5A AC (AVG)	1mA	246300-36-AFA	237300-36-AFA	Watt 3P4W	1mA	246540-46-AFA-N	237540-46-AFA-N
5A AC (TRMS)	1mA	246400-36-AFA-2	237400-36-AFA-2	(120V, 5A)	4-20mA	246540-46-AHE-N	237540-46-AHE-N
	4-20mA	246400-36-AHE-2	237400-36-AHE-2	VAR 3P3W	±1mA	246630-46-AFB-M	237630-46-AFB-M
150V AC (AVG)	1mA	246300-32-AFA	237300-32-AFA	(120V, 5A)	4-20mA	246630-46-AHE-M	237630-46-AHE-M
150V AC (TRMS)	1mA	246400-32-AFA-2	237400-32-AFA-2	VAR 3P4W	±1mA	246640-46-AFB-M	237640-46-AFB-M
	4-20mA	246400-32-AHE-2	237400-32-AHE-2	(120V, 5A)	4-20mA	246640-46-AHE-M	237640-46-AHE-M
Watt 3P3W	1mA	246530-46-AFA-N	237530-46-AFA-N	PA 3P3W	±1mA	246730-46-AFB-P	237730-46-AFB-P
(120V, 5A)	4-20mA	246530-46-AHE-N	237530-46-AHE-N	(120V, 5A)	4-20mA	246730-46-AHE-P	237730-46-AHE-P



237 = Foot mount
246 = DIN rail

(1) Transducer function

100	DC / DC isolator
------------	------------------

200	AC Amp or Volt (Mean value)
300	AC Amp or Volt (RMS value)
400	AC Amp or Volt (True RMS)

xx*(select one)

5XX*	Watt	10	1P2W	45	AC 120V / 1A
6XX*	VAR	20	1P3W	46	AC 120V / 5A
7XX*	Phase Angle	30	3P3W	47	AC 240V / 1A
		40	3P4W	48	AC 240V / 5A

xx*(select one)

8XX*	Frequency	01	45-55 Hz	37	AC 120V
		02	55-65 Hz	38	AC 240V
		03	45-65 Hz		

(2) Rated inputs

01	DC 50mV
02	DC 1V
03	DC 5V
04	DC 10V
05	DC 25V
06	DC 65V
21	DC 1mA

32	AC 150V
34	AC 300V
35	AC 1A
36	AC 5A

(3) **Rated outputs

AFA	0-1mADC
AFX	0-5mADC
AFB	± 1mADC
AFZ	± 5mADC
AHE	4 - 20mADC
VGZ	0 - 10mVDC
VLS	0 - 5VDC
VMT	0 - 10VDC
VHB	± 10mVDC
VLU	± 5VDC
VLY	± 6VDC
VMS	± 10VDC
VME	4.5-6.5VDC

(4) Auxiliary power

2	120 VAC 50/60 Hz
4	240 VAC 50/60 Hz
Only required for function 100 DC/DC & 400 TRMS	

Polarity (Watt/VAR/PA only)

N	No polarity (Watt only)
P	-Lag to +Lead
M	-Lead to +Lag

** Outputs available by transducer function:

FUNCTION	CODE#	AFA	AFX	AFB	AFZ	AHE	VGZ	VLS	VMT	VHB	VLU	VLY	VMS	VME
	OUTPUT	1mA	5mA	±1mA	±5mA	4-20mA	10mV	5V	10V	±10mV	±5V	±6V	±10V	4.5-6.5V
100 DC / DC isolator		X	X	-	-	X	X	X	X	-	-	-	-	-
200 AC Amp / Volt		X	X	-	-	-	-	-	-	-	-	-	-	-
300 AC Amp / Volt		X	-	-	-	-	X	X	-	-	-	-	-	-
400 AC Amp / Volt		X	X	-	-	X	X	X	X	-	-	-	-	-
5XX Watt		X	X	-	-	X	X	X	X	-	-	-	-	-
6XX VAR		-	-	X	X	X	-	-	-	X	X	-	X	-
7XX Phase Angle		-	-	X	X	X	-	-	-	X	-	X	-	-
801 / 802 Frequency		X	X	-	-	X	X	-	X	X	-	-	-	-
803 Frequency		X	X	-	-	X	X	X	X	-	-	-	-	X

6) CONNECTION DIAGRAMS

<p>DC/DC isolator 2371 2461</p>			<table border="1" style="width:100%; border-collapse: collapse;"> <thead> <tr> <th>Terminal No's.</th> <th>Symbol</th> </tr> </thead> <tbody> <tr><td>2</td><td>-</td></tr> <tr><td>3</td><td>+</td></tr> <tr><td>5</td><td>V</td></tr> <tr><td>6</td><td>±</td></tr> <tr><td>A</td><td>⏏</td></tr> <tr><td>B</td><td>-</td></tr> <tr><td>C</td><td>+</td></tr> </tbody> </table>	Terminal No's.	Symbol	2	-	3	+	5	V	6	±	A	⏏	B	-	C	+																							
Terminal No's.	Symbol																																									
2	-																																									
3	+																																									
5	V																																									
6	±																																									
A	⏏																																									
B	-																																									
C	+																																									
<p>AC voltage/ current 2372 2373 2462 2463</p>	<p>Current input</p>	<table border="1" style="width:100%; border-collapse: collapse;"> <thead> <tr> <th>Terminal No's.</th> <th>Symbol</th> </tr> </thead> <tbody> <tr><td>2</td><td>A</td></tr> <tr><td>3</td><td>±</td></tr> <tr><td>A</td><td>⏏</td></tr> <tr><td>B</td><td>-</td></tr> <tr><td>C</td><td>+</td></tr> </tbody> </table>	Terminal No's.	Symbol	2	A	3	±	A	⏏	B	-	C	+	<p>Voltage input</p>	<table border="1" style="width:100%; border-collapse: collapse;"> <thead> <tr> <th>Terminal No's.</th> <th>Symbol</th> </tr> </thead> <tbody> <tr><td>2</td><td>V</td></tr> <tr><td>3</td><td>±</td></tr> <tr><td>A</td><td>⏏</td></tr> <tr><td>B</td><td>-</td></tr> <tr><td>C</td><td>+</td></tr> </tbody> </table>	Terminal No's.	Symbol	2	V	3	±	A	⏏	B	-	C	+														
Terminal No's.	Symbol																																									
2	A																																									
3	±																																									
A	⏏																																									
B	-																																									
C	+																																									
Terminal No's.	Symbol																																									
2	V																																									
3	±																																									
A	⏏																																									
B	-																																									
C	+																																									
<p>AC voltage/ current 2374 2464</p>	<p>Current input</p>	<table border="1" style="width:100%; border-collapse: collapse;"> <thead> <tr> <th>Terminal No's.</th> <th>Symbol</th> </tr> </thead> <tbody> <tr><td>2</td><td>A</td></tr> <tr><td>3</td><td>±</td></tr> <tr><td>5</td><td>V</td></tr> <tr><td>6</td><td>±</td></tr> <tr><td>A</td><td>⏏</td></tr> <tr><td>B</td><td>-</td></tr> <tr><td>C</td><td>+</td></tr> </tbody> </table>	Terminal No's.	Symbol	2	A	3	±	5	V	6	±	A	⏏	B	-	C	+	<p>Voltage input</p>	<table border="1" style="width:100%; border-collapse: collapse;"> <thead> <tr> <th>Terminal No's.</th> <th>Symbol</th> </tr> </thead> <tbody> <tr><td>2</td><td>V</td></tr> <tr><td>3</td><td>±</td></tr> <tr><td>5</td><td>V</td></tr> <tr><td>6</td><td>±</td></tr> <tr><td>A</td><td>⏏</td></tr> <tr><td>B</td><td>-</td></tr> <tr><td>C</td><td>+</td></tr> </tbody> </table>	Terminal No's.	Symbol	2	V	3	±	5	V	6	±	A	⏏	B	-	C	+						
Terminal No's.	Symbol																																									
2	A																																									
3	±																																									
5	V																																									
6	±																																									
A	⏏																																									
B	-																																									
C	+																																									
Terminal No's.	Symbol																																									
2	V																																									
3	±																																									
5	V																																									
6	±																																									
A	⏏																																									
B	-																																									
C	+																																									
<p>Power/ Reactive Power 2375 2376 2465 2466</p>	<p>Single-phase, 2-wire</p>	<table border="1" style="width:100%; border-collapse: collapse;"> <thead> <tr> <th>Terminal No's.</th> <th>Symbol</th> </tr> </thead> <tbody> <tr><td>2</td><td>1S</td></tr> <tr><td>3</td><td>1L</td></tr> <tr><td>7</td><td>P1</td></tr> <tr><td>8</td><td>P2</td></tr> <tr><td>A</td><td>⏏</td></tr> <tr><td>B</td><td>-</td></tr> <tr><td>C</td><td>+</td></tr> </tbody> </table>	Terminal No's.	Symbol	2	1S	3	1L	7	P1	8	P2	A	⏏	B	-	C	+	<p>Single-phase, 3-wire</p>	<table border="1" style="width:100%; border-collapse: collapse;"> <thead> <tr> <th>Terminal No's.</th> <th>Symbol</th> </tr> </thead> <tbody> <tr><td>1</td><td>1S</td></tr> <tr><td>2</td><td>1L</td></tr> <tr><td>3</td><td>3S</td></tr> <tr><td>4</td><td>3L</td></tr> <tr><td>7</td><td>P1</td></tr> <tr><td>8</td><td>P0</td></tr> <tr><td>9</td><td>P2</td></tr> <tr><td>A</td><td>⏏</td></tr> <tr><td>B</td><td>-</td></tr> <tr><td>C</td><td>+</td></tr> </tbody> </table>	Terminal No's.	Symbol	1	1S	2	1L	3	3S	4	3L	7	P1	8	P0	9	P2	A	⏏	B	-	C	+
Terminal No's.	Symbol																																									
2	1S																																									
3	1L																																									
7	P1																																									
8	P2																																									
A	⏏																																									
B	-																																									
C	+																																									
Terminal No's.	Symbol																																									
1	1S																																									
2	1L																																									
3	3S																																									
4	3L																																									
7	P1																																									
8	P0																																									
9	P2																																									
A	⏏																																									
B	-																																									
C	+																																									

6) CONNECTION DIAGRAMS (CONTINUED)

<p>Power/ Reactive Power 2375 2376 2465 2466</p>	<p>3-phase, 3-wire</p>	<p>3-phase, 4-wire</p>
	<p>237530 237630 246530 246630</p>	<p>237540 237640 246540 246640</p>
<p>Phase Angle 2377 2467</p>	<p>Single-phase, 2-wire</p>	<p>Single-phase, 3-wire</p>
	<p>237710 246710</p>	<p>237720 246720</p>
	<p>3-phase, 3-wire</p>	<p>3-phase, 4-wire</p>
	<p>237730 246730</p>	<p>237740 246740</p>
<p>Frequency 2378 2468</p>	<p>3-phase, 3-wire</p>	

PLASTIC CASE MINIATURE TRANSDUCERS

7) MOUNTING DIMENSIONS AND TERMINAL BOARD LAYOUT: millimeters (inches)

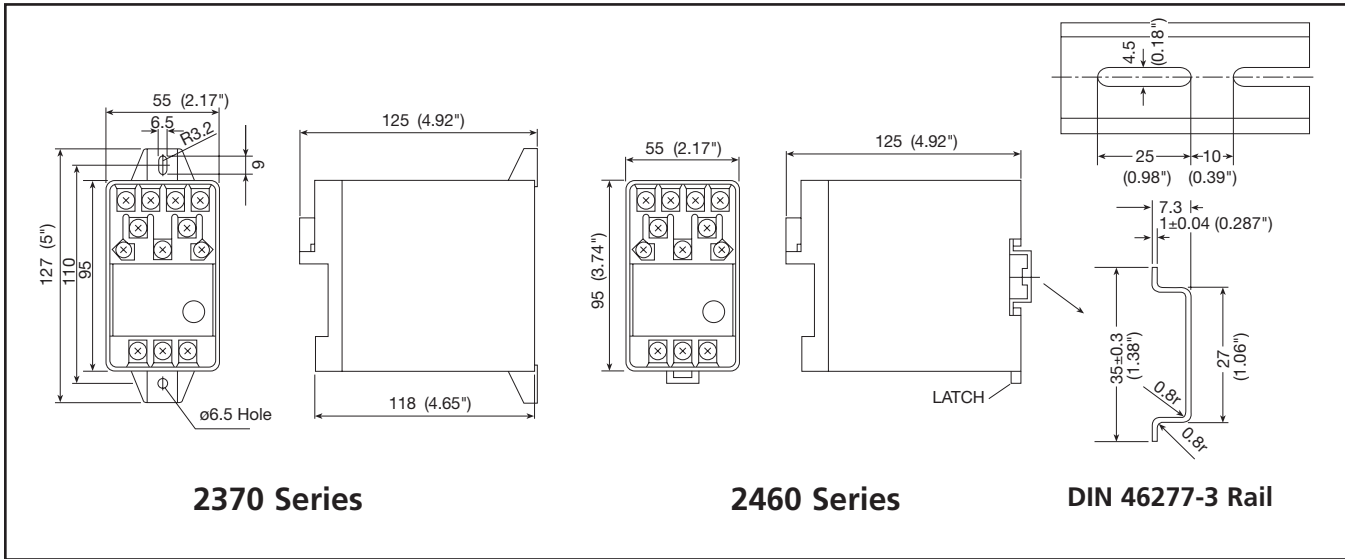

Mounting Side by Side

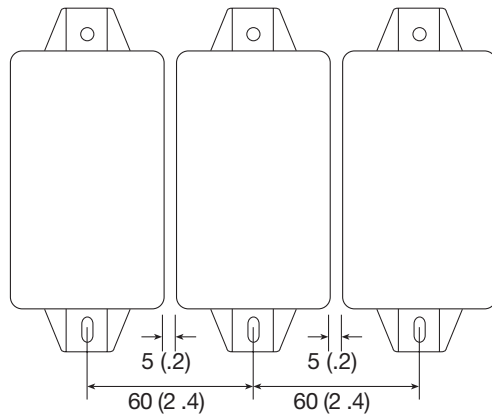

(Caution)

When putting 2 or more transducers side by side, separate the distance between mounting holes of the adjacent transducers by more than 60 mm.

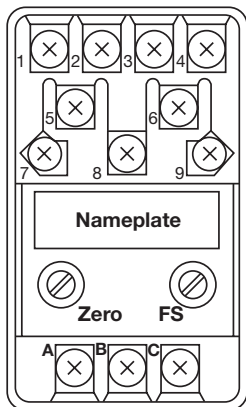

Terminal Board Layout



Terminal arrangement		Variable resistor for zero adjustment Variable range: $\pm 20\%$ or more
1 — 4	Input terminals	 ZERO
5 — 6	*Auxiliary power terminals	Variable resistor for span adjustment Variable range: $\pm 5\%$ or more
7 — 9	Input terminals	
A — C	Output terminals	 FS

*Also input terminal for 3P4W Watt/VAR

Other Catalogs Available . . .

Power Series Plus



The Power Series Plus digital switchboard meter was developed by Yokogawa to provide customers with a versatile AC digital power meter. The heart of the meter is a programmable ASIC chip which allows us to combine a high accuracy meter with transducer output.

Current & Potential Transformers

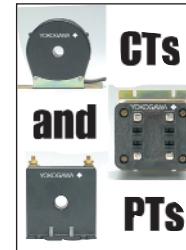

Yokogawa CT's and PT's provide high accuracy inputs to transformer-rated AC switchboard instruments and power transducers.

Portable Test Instruments



Yokogawa has a wide range of Portable Test Instruments including clamp-on testers, calibrators, digital multimeters, insulation testers, and digital thermometers.

Panel Meters

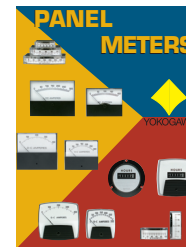

Yokogawa has the broadest line of panel meters available today. In many cases, our panel meters are completely interchangeable with other manufacturer's products. UL and IP54 splash resistant models are available.

Digital Panel Meters

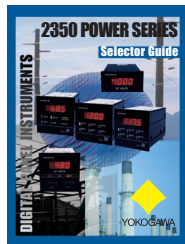

The 2350 Series Digital Panel meters provide high accuracy read out of AC and DC inputs and are capable of retransmitting analog signals to remote monitors, recorders and control systems. Available in 1/8 and 1/4 DIN case with single and multifunction capability.

Switchboard Instruments



Yokogawa is the world leader in Analog Switchboard Instruments. Our catalog contains the entire switchboard line including AB/DB 14, 16, 17 and 40, and type 180 edgewise. It also includes the 2180 mini-switchboard meters, potential transformers, transducers and digital switchboard meters.



YOKOGAWA 
 Yokogawa Corporation of America

2 Dart Road
 Newnan, GA 30265
 770-253-7000
 800-258-2552
 FAX: 770-251-2088

Represented by:



BU-JAC-07E