

GSD

M39012/31-0001

REVISIONS

ISSUE	CHANGES
13	CN 36587 C REDRAWN ME 09/25/95

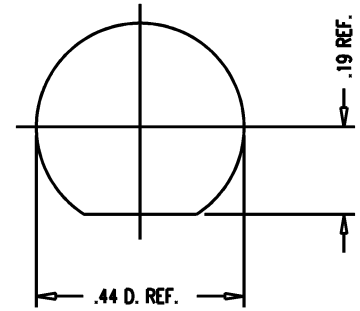
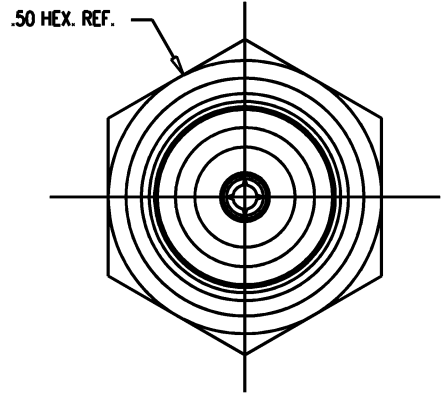
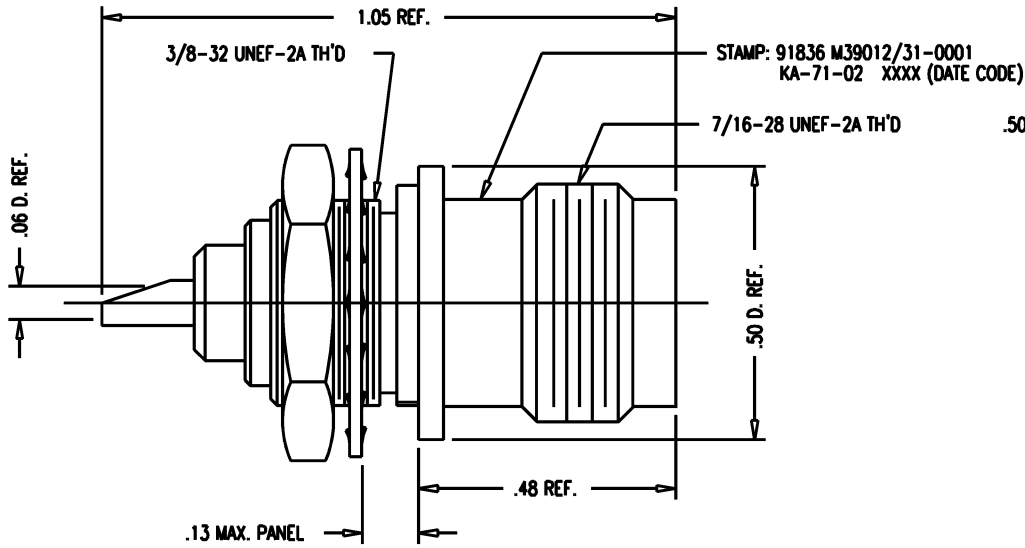

MOUNTING HOLE

KA-71-02 QGS0871

SCALE 4:1

APPROX SURFACE AREA

USED ON

REF:

RECEPTACLE,
TNC, BULKHEAD

DRAWN ME 09/25/95

DESIGN MJB 09/25/95

APPR. DATE

KINGS
ELECTRONICS CO., INC.
TUCKAHOE, NEW YORK 10707

M39012/31-0001

GSD

NOTES:

- INTERFACE PER MIL-STD-348, FIG. 313-2.
- MATERIALS:
INSULATOR: TEFLON, ASTM-D-4894
LOCKWASHER: PHOSPHOR BRONZE, ASTM-B-103
CENTER CONTACT: BER. COPPER, ASTM-B-196
ALL OTHER METAL PARTS: BRASS, ASTM-B16
- FINISHES:
CENTER CONTACT: HARD GOLD PLATE PER MIL-G-45204
ALL OTHER METAL PARTS: SILVER PLATE, PER QQ-S-365
- ELECTRICAL CHARACTERISTICS:
NOMINAL IMPEDANCE: 50 Ω W
FREQUENCY RANGE: DC TO 11 GHz
WORKING VOLTAGE: 500 VOLTS RMS