



# 10RIA, 16RIA, 22RIA, 25RIA SERIES

## 25A, 35A And 40A RMS Glass-passivated SCRs

### Major Ratings and Characteristics

	10RIA	16RIA	22RIA	25RIA	Units
$I_{T(RMS)}$	25	35	35	40	A
$I_{T(AV)}$	10	16	22	25	A
@ Max. $T_C$	85	85	85	85	$^{\circ}C$
$I_{TSM}$ @ 50 Hz	190	285	335	350	A
@ 60 Hz	200	300	355	370	
$I^2t$ @ 50 Hz	180	405	560	615	A <sup>2</sup> s
@ 60 Hz	165	375	515	560	
$I_{GT}$	60	60	60	60	mA
dv/dt	100	100	100	100	V/ $\mu$ s
di/dt	200	200	200	200	A/ $\mu$ s
$T_J$	-40 to 125				$^{\circ}C$
$V_{DRM}, V_{RRM}$ range	100 to 1200				V

### Description/Features

The RIA series of silicon controlled rectifiers are reverse blocking triode thyristor devices designed for medium power switching and phase control applications.

- New and improved glass passivation for high reliability and exceptional stability at high temperatures.
- 100V through 1200V
- Integral TO-208AA package
- Low thermal resistance
- High di/dt and dv/dt capabilities
- Can be supplied to meet stringent military, aerospace and other high-reliability requirements.
- Available to CECC 50 000.

### CASE STYLE AND DIMENSIONS

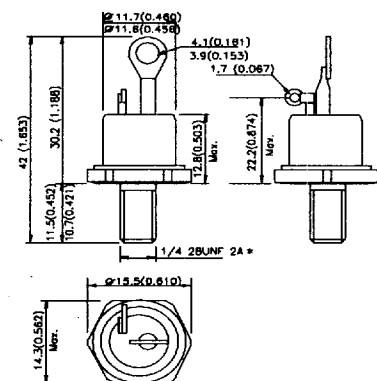
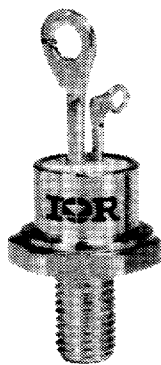

Conforms to JEDEC OUTLINE TO-208AA (TO-48)  
Dimensions in Millimeters and (Inches)

VOLTAGE RATINGS (Applied gate voltage zero or negative):

Part Number ②				VRRM	VDRM	VRSM	IRM, IDM Max. Peak Reverse and Off-State Leakage Current (ma) ①
				Max. Rep. Peak Reverse Voltage (V)	Max. Rep. Peak Off-State Voltage (V)	Max. Non-Rep. Peak Reverse Voltage (V) $t_p < 5ms$	
				$T_J = -65$ to $125^{\circ}C$	$T_J = -65$ to $125^{\circ}C$	$T_J = 25$ to $125^{\circ}C$	
10RIA10	16RIA10	22RIA10	25RIA10	100	100	150	20
10RIA20	16RIA20	22RIA20	25RIA20	200	200	300	10
10RIA40	16RIA40	22RIA40	25RIA40	400	400	500	10
10RIA60	16RIA60	22RIA60	25RIA60	600	600	700	10
10RIA80	16RIA80	22RIA80	25RIA80	800	800	900	10
10RIA100	16RIA100	22RIA100	25RIA100	1000	1000	1100	10
10RIA120	16RIA120	22RIA120	25RIA120	1200	1200	1300	10

ELECTRICAL SPECIFICATIONS

		10RIA	16RIA	22RIA	25RIA	Units	Conditions
<b>ON-STATE</b>							
$I_T(RMS)$	Max. RMS on-state current	25	35	35	40	A	
$I_T(AV)$	Max. average on-state current	10	16	22	25	A	$T_C = 85^{\circ}C$ , half sine wave, $180^{\circ}$ conduction
		16	22	—	—	A	10RIA, Max $T_C = 51^{\circ}C$ ; 16RIA, $T_C = 60^{\circ}C$
		8.5	11.5	13	14.5	A	$T_A = 45^{\circ}C$ , half sine wave, K3 sink natural cooling, $180^{\circ}$ conduction
		8	11	12.5	14.0	A	$T_A = 45^{\circ}C$ , rectangular wave K3 sink natural cooling, $120^{\circ}$ conduction
$I_{TSM}$	Max. peak one cycle, non-repetitive surge current with rated reverse voltage applied following surge	190	285	335	350	A	50Hz, Initial $T_J = 125^{\circ}C$ 100% rated $V_{RRM}$ reapplied
		225	335	390	395	A	50Hz, Initial $T_J = 45^{\circ}C$ 100% rated $V_{RRM}$ reapplied
		200	300	355	370	A	60Hz, Initial $T_J = 125^{\circ}C$ 100% rated $V_{RRM}$ reapplied
		240	350	410	415	A	60Hz, Initial $T_J = 45^{\circ}C$ 100% rated $V_{RRM}$ reapplied
	Max. peak one cycle, non-repetitive surge current with no reverse voltage following surge	225	340	400	420	A	50Hz, Initial $T_J = 125^{\circ}C$ no voltage reapplied
		270	395	460	470	A	50Hz, Initial $T_J = 45^{\circ}C$ no voltage reapplied
		240	360	420	440	A	60Hz, Initial $T_J = 125^{\circ}C$ no voltage reapplied
		280	415	480	495	A	60Hz, Initial $T_J = 45^{\circ}C$ no voltage reapplied
$I^2t$	Max. $I^2t$ capability, for fusing	180	405	560	615	$A^2s$	$t = 10ms$ , Initial $T_J = 125^{\circ}C$ 100% rated $V_{RRM}$ reapplied
		255	555	755	780	$A^2s$	$t = 10ms$ , Initial $T_J = 45^{\circ}C$ 100% rated $V_{RRM}$ reapplied
		165	375	515	560	$A^2s$	$t = 8.3ms$ , Initial $T_J = 125^{\circ}C$ 100% rated $V_{RRM}$ reapplied
		235	510	690	720	$A^2s$	$t = 8.3ms$ , Initial $T_J = 45^{\circ}C$ 100% rated $V_{RRM}$ reapplied



ELECTRICAL SPECIFICATIONS (Continued)

	10RIA	16RIA	22RIA	25RIA	Units	Conditions
--	-------	-------	-------	-------	-------	------------

[The table content is almost entirely obscured by heavy black redaction bars.]

ELECTRICAL SPECIFICATIONS (Continued)

		10RIA	16RIA	22RIA	25RIA	Units	Conditions
TRIGGERING (Continued)							
V <sub>GT</sub>	Max. required DC gate voltage to trigger ⑤	3.0				V	Anode supply = 6V, resistive load, T <sub>J</sub> = -65°C
		2.0				V	Anode supply = 6V, resistive load, T <sub>J</sub> = 25°C
		1.0				V	Anode supply = 6V, resistive load, T <sub>J</sub> = 125°C
V <sub>GD</sub>	Max. DC gate voltage not to trigger ⑥	0.2				V	T <sub>J</sub> = 125°C V <sub>DRM</sub> = rated value
I <sub>GD</sub>	Max. DC gate current not to trigger	2.0				mA	T <sub>J</sub> = 125°C, V <sub>DRM</sub> = rated value
SWITCHING							
t <sub>gt</sub>	Typical turn-on time	0.9				μs	T <sub>J</sub> = 25°C ⑦
t <sub>rr</sub>	Typical reverse recovery time	4				μs	T <sub>J</sub> = 125°C ⑧
t <sub>q</sub> ⑩	Typical turn-off time	110				μs	T <sub>J</sub> = 125°C ⑨

THERMAL-MECHANICAL SPECIFICATIONS

T <sub>J</sub>	Operating junction temperature range	-65 to 125				°C	
T <sub>stg</sub>	Storage temperature range	-65 to 150				°C	
R <sub>thJC</sub>	Max. thermal resistance, junction to case	1.85	1.15	0.86	0.75	deg C/W	DC operation
R <sub>thCS</sub>	Max. thermal resistance, case to sink	0.35				deg C/W	Mounting surface smooth, flat and greased
T	Mounting torque ±10%	to nut		to device		lbf · in.	Lubricated threads and (non-lubricated threads)
		20(27.5)		25			
		0.23(.32)		0.29		kgf · m	
		2.3(3.1)		2.8		N · m	
wt	Approximate weight	14 (0.49)				g (oz)	
	Case Style	TO-208AA (TO-48)					JEDEC

NOTES

- ① At rated V<sub>RRM</sub>, V<sub>DRM</sub>, T<sub>J</sub> = 125°C.
- ② I<sup>2</sup>t for time t<sub>x</sub> = I<sup>2</sup>√t · √t<sub>x</sub>.
- ③ From 0.67 rated V<sub>DRM</sub>, T<sub>J</sub> = 125°C. Peak gate current = 0.5A, rise time 1 μs, pulse duration at least 6 μs. 300 pulses at 50 or 60 Hz. I<sub>TM</sub> = (2x rated di/dt)A. Per JEDEC Standard RS-397, 5.2.2.6.
- ④ Max. required gate current to trigger is lowest value which will trigger all units under conditions shown.
- ⑤ Max. required gate voltage to trigger is lowest value which will trigger all units under conditions shown.
- ⑥ Max. gate voltage not to trigger is the maximum value that will not trigger any unit under the conditions shown.  
Gate current = 200mA, rise time 0.5 μs, pulse duration at least 6 μs, V<sub>D</sub> = 0.5 rated V<sub>DRM</sub> Resistive circuit. I<sub>TM</sub> = 0.1 x I<sub>T(AV)</sub>.
- ⑦ I<sub>TM</sub> = rated I<sub>T(AV)</sub> for at least 200 μs, di<sub>R</sub>/dt = -10A/μs.
- ⑧ I<sub>TM</sub> = rated I<sub>T(AV)</sub>, for at least 200 μs duration, di<sub>R</sub>/dt = -10A/μs. Minimum reverse voltage during turn-off = 100V, reapplied dv/dt = 20V/μs exponential to 0.67 V<sub>DRM</sub>. Gate bias: 0V, 100Ω.
- ⑨ For M6 threads add "M" to code, e.g., 16RIA40M.
- ⑩ The following values of t<sub>q</sub> = 10 μs up to 600V and 30 μs up to 1200V are available on special request.

10RIA Series

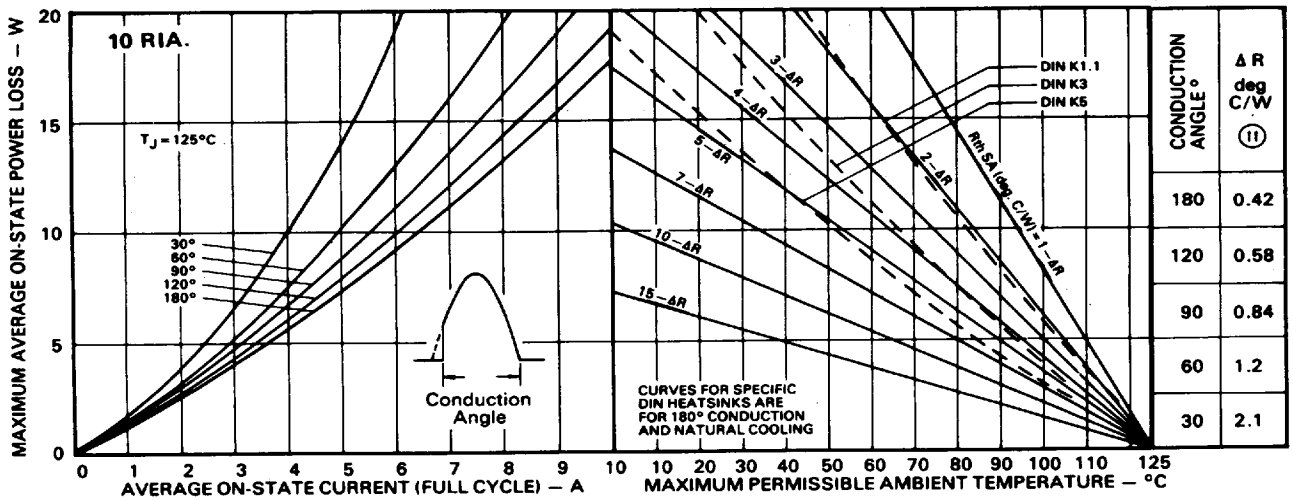

Fig. 1 - Continuous Current Rating Nomogram (Phase Angle Controlled Half-Sinusoidal Waveforms, 50-400 Hz), 10RIA Series.

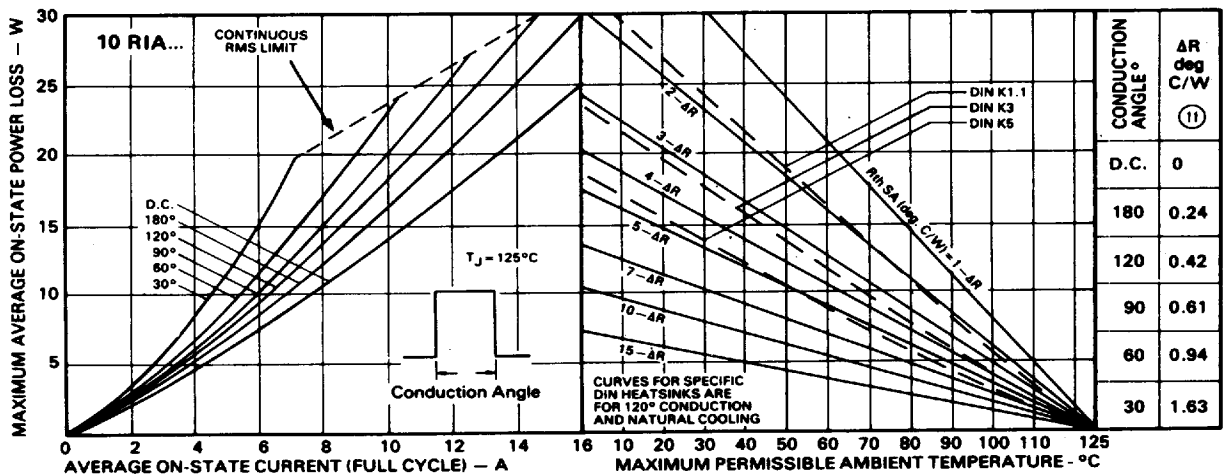

Fig. 2 - Continuous Current Rating Nomogram (Rectangular Waveforms, 50-400 Hz), 10RIA Series.

① To determine required heatsink thermal resistance ( $R_{thSA}$ ) in deg C/W use value of  $\Delta R$  appropriate to conduction angle stated in table and substitute in formula  $R_{thSA} = X - \Delta R$ , e.g. for 10RIA at 180° conduction angle, 7.6A, and 60°C ambient temperature  $R_{thSA} = 3 - 0.42 = 2.58$  deg. C/W (figs. 1 & 2)

5

10RIA Series

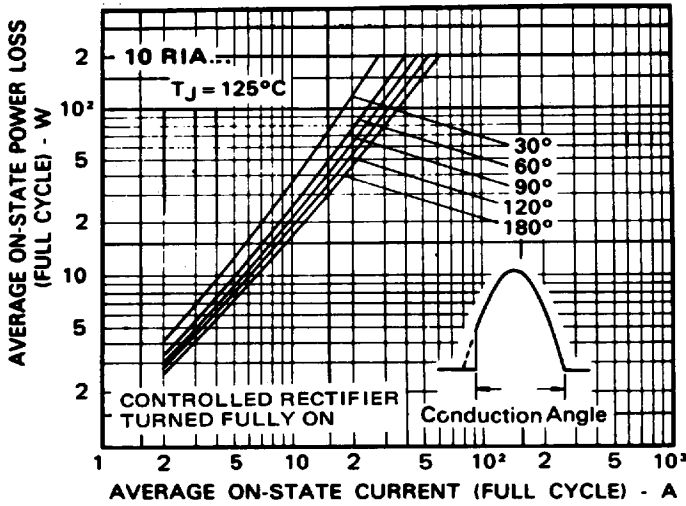

Fig. 3 — Maximum High Level On-State Power Loss Vs. Average On-State Current (Sinusoidal Current Waveform), 10RIA Series

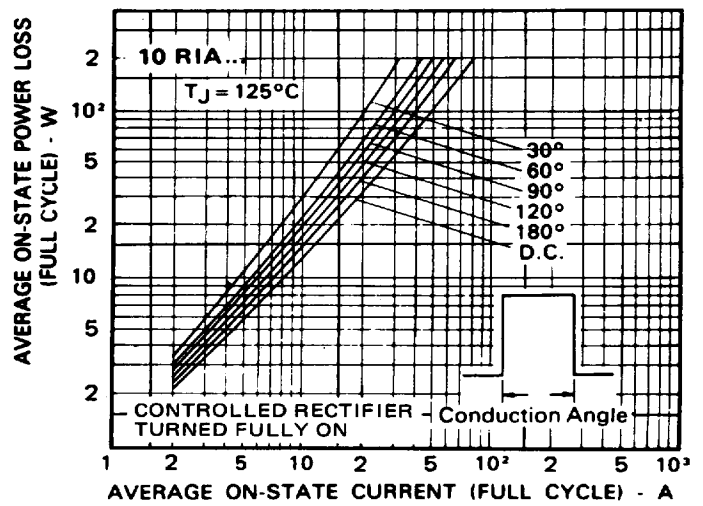

Fig. 4 — Maximum High Level On-State Power Loss Vs. Average On-State Current (Rectangular Current Waveform) 10RIA Series

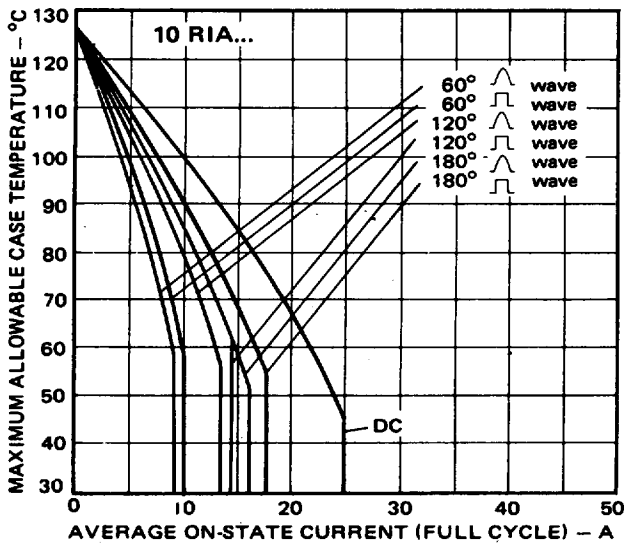

Fig. 5 — Average On-State Current Vs. Maximum Allowable Case Temperature (Rectangular and Sinusoidal Current Waveform, 50–400 Hz), 10RIA Series.

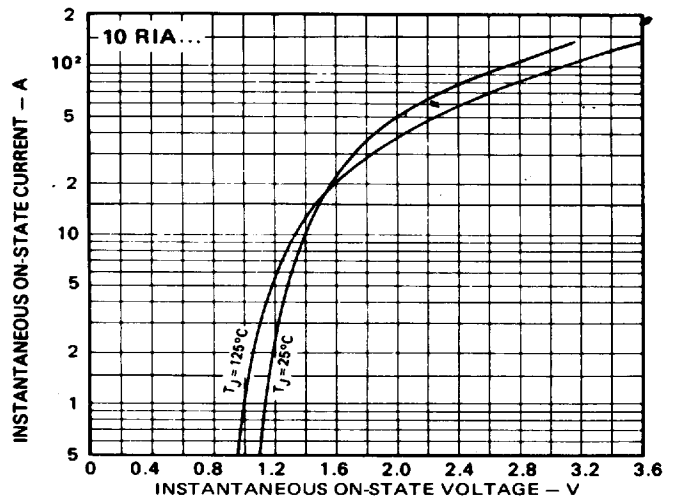

Fig. 6 — Maximum Instantaneous On-State Voltage Vs. Instantaneous On-State Current, 10RIA Series

able Case Temperature (Rectangular and Sinusoidal Current Waveform, 50–400 Hz), 10RIA Series.

Instantaneous On-State Current, 10RIA Series

10RIA Series

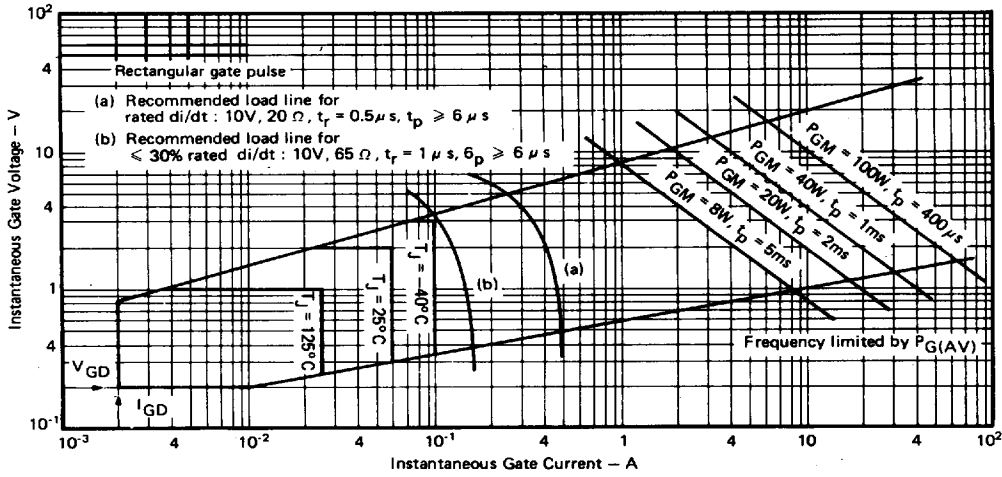

Fig. 7 - Gate Characteristics, 10RIA Series

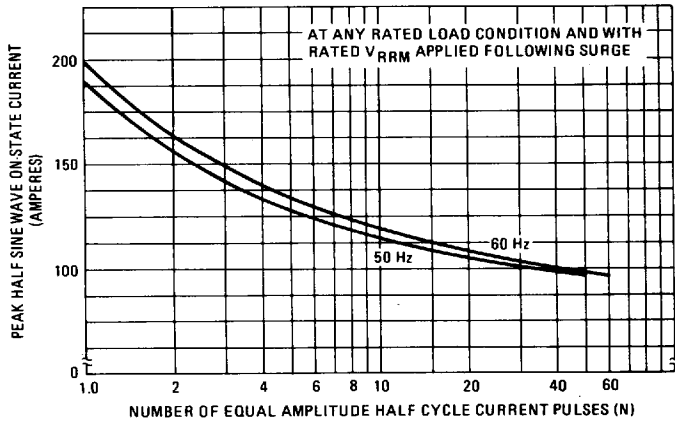

Fig. 8 - Maximum Non-Repetitive Surge Current Vs. Number of Current Pulses, 10RIA Series

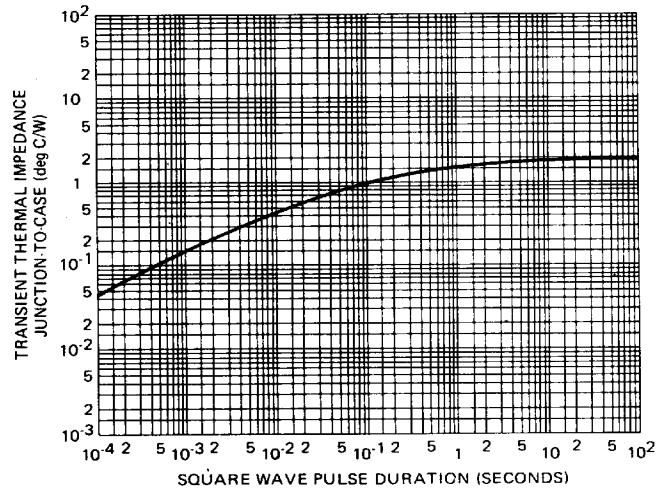

Fig. 9 - Maximum Transient Thermal Impedance, Junction-to-Case Vs. Pulse Duration, 10RIA Series

7

16RIA Series

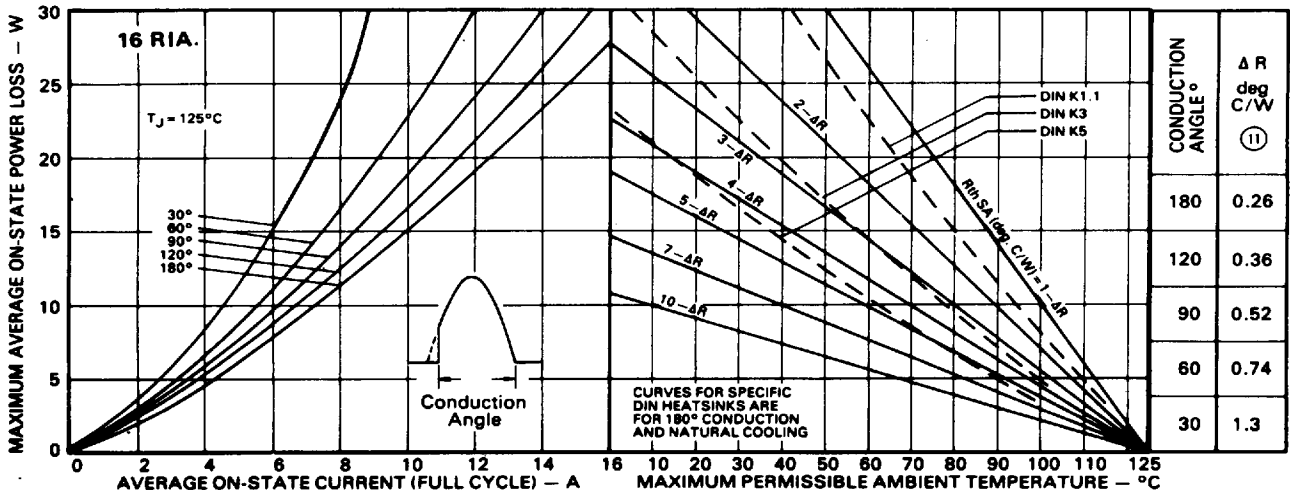

Fig. 10 - Continuous Current Rating Nomogram (Phase Angle Controlled Half-Sinusoidal Waveforms, 50-400 Hz), 16RIA Series.

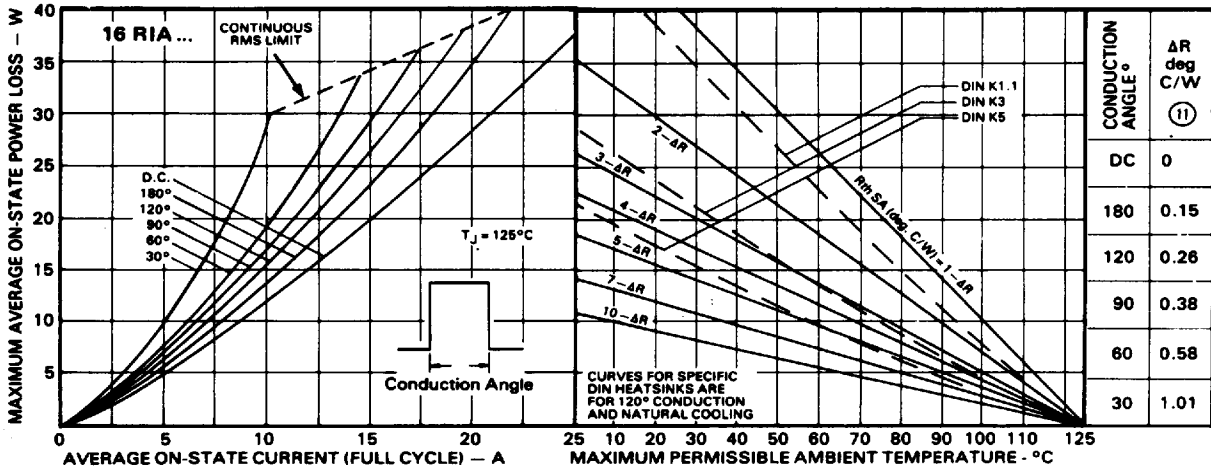

Fig. 11 - Continuous Current Rating Nomogram (Rectangular Waveforms, 50-400 Hz), 16RIA Series.

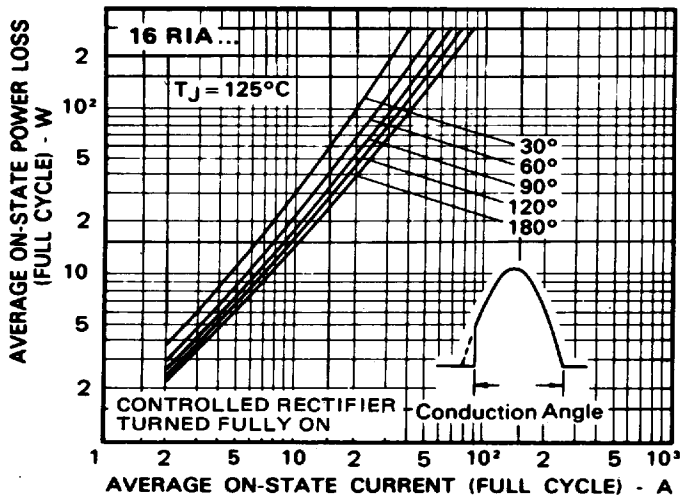

Fig. 12 - Maximum High Level On-State Power Loss Vs. Average On-State Current (Sinusoidal Current Waveform), 16RIA Series

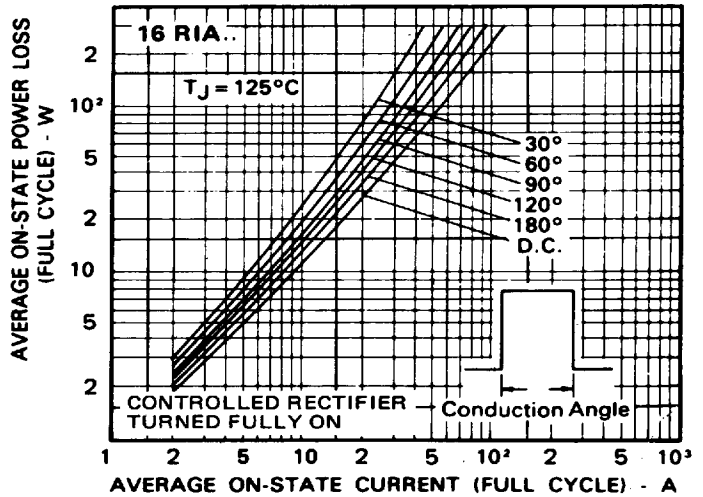

Fig. 13 - Maximum High Level On-State Power Loss Vs. Average On-State Current (Rectangular Current Waveform)

① See page A-13 for note.

8



16RIA Series

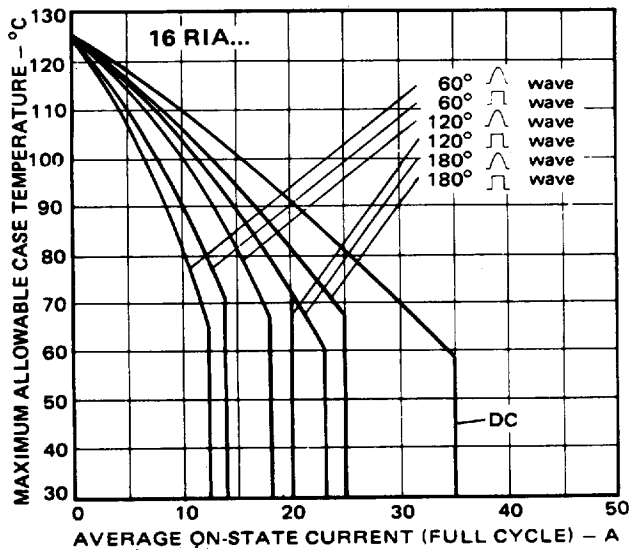

Fig. 14 - Average On-State Current Vs. Maximum Allowable Case Temperature (Rectangular and Sinusoidal Current Waveform, 50-400 Hz), 16RIA Series.

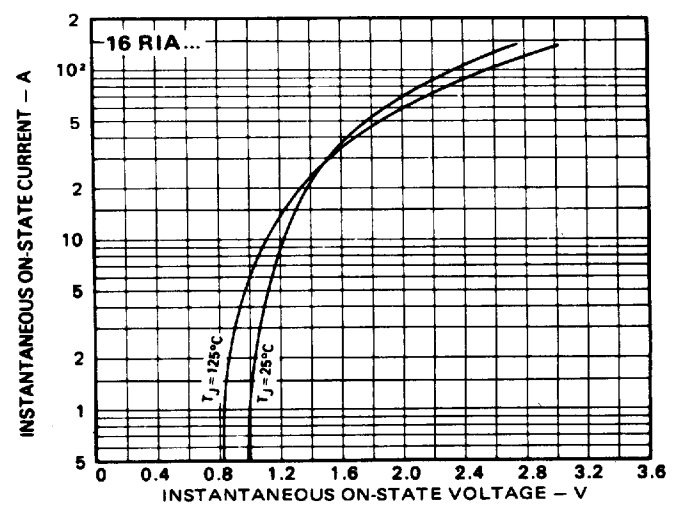

Fig. 15 - Maximum Instantaneous On- State Voltage Vs. Instantaneous On- State Current, 16RIA Series

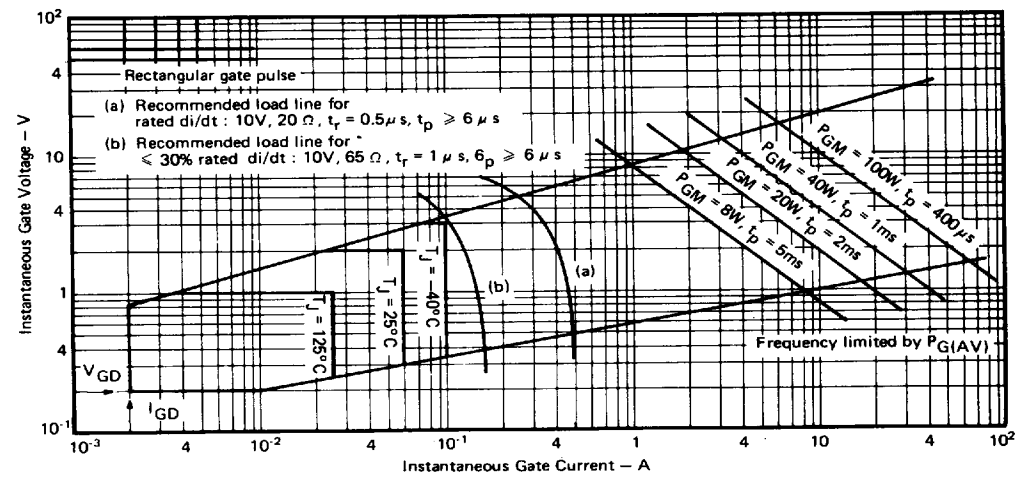

Fig. 16 - Gate Characteristics, 16RIA Series

9



16RIA Series

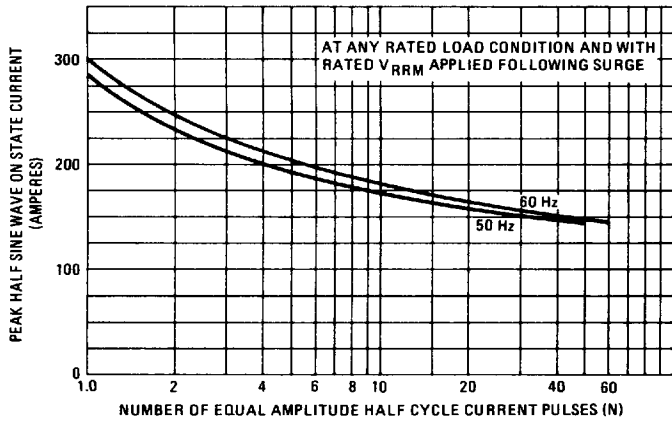

Fig. 17 — Maximum Non-Repetitive Surge Current Vs. Number of Current Pulses, 16RIA Series

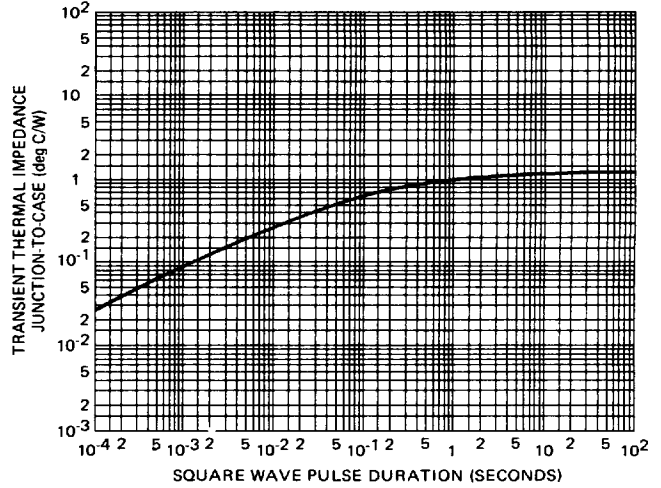

Fig. 18 — Maximum Transient Thermal Impedance, Junction-to-Case Vs. Pulse Duration, 16RIA Series

22RIA Series

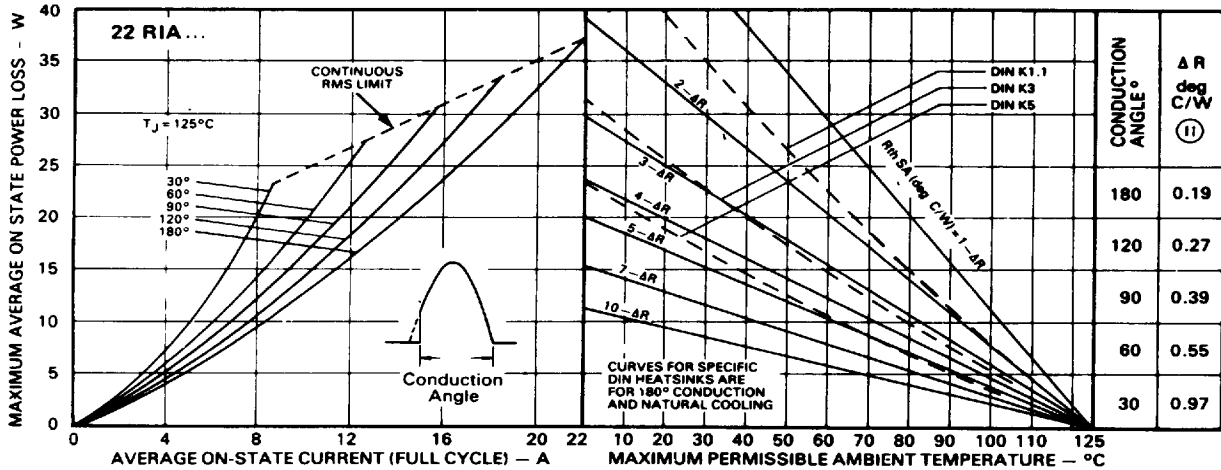

Fig. 19 — Continuous Current Rating Nomogram (Phase Angle Controlled Half-Sinusoidal Current Waveforms, 50–400 Hz), 22RIA Series.

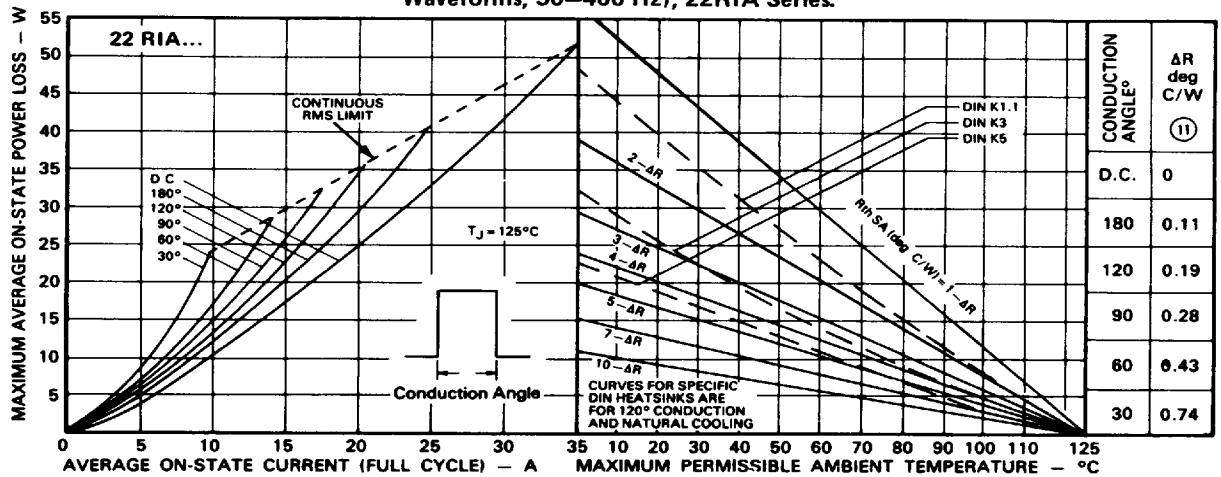

Fig. 20 — Continuous Current Rating Nomogram (rectangular Waveforms, 50–400 Hz), 22RIA Series.

22RIA Series

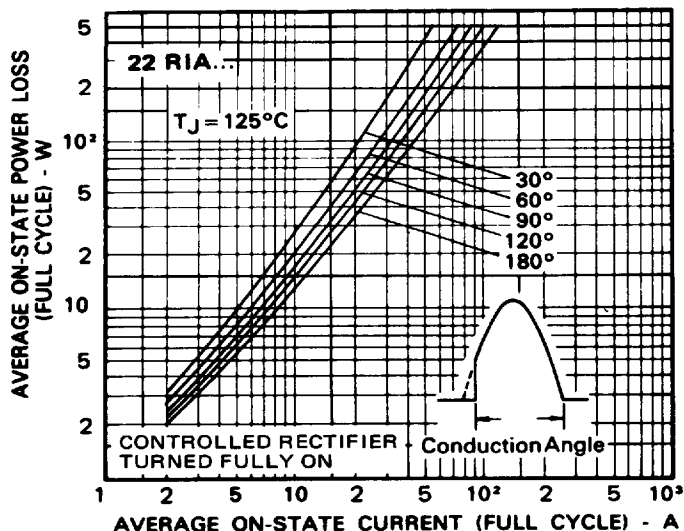

Fig. 21 - Maximum High Level On-State Power Loss Vs. Average On-State Current (Sinusoidal Current Waveform), 22RIA Series

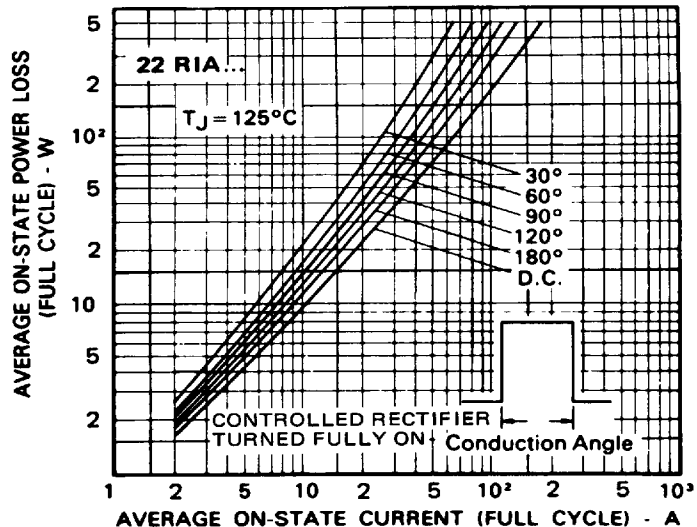

Fig. 22 - Maximum High Level On-State Power Loss Vs. Average On-State Current (Rectangular Current Waveform) 22RIA Series

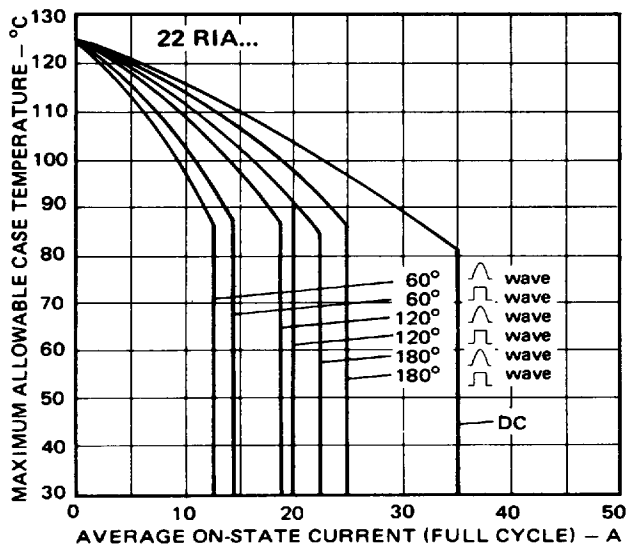

Fig. 23 - Average On-State Current Vs. Maximum Allowable Case Temperature (Sinusoidal Current Waveform, 50 to 400 Hz), 22RIA Series

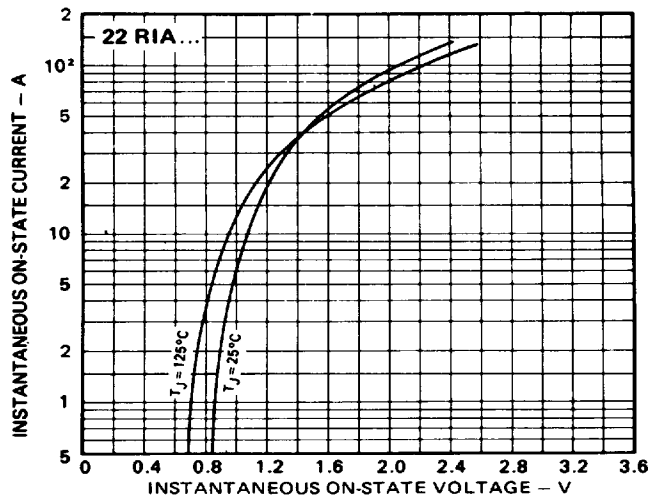

Fig. 24 - Maximum Instantaneous On-State Voltage Vs. Instantaneous On-State Current, 22RIA Series

//

22RIA Series

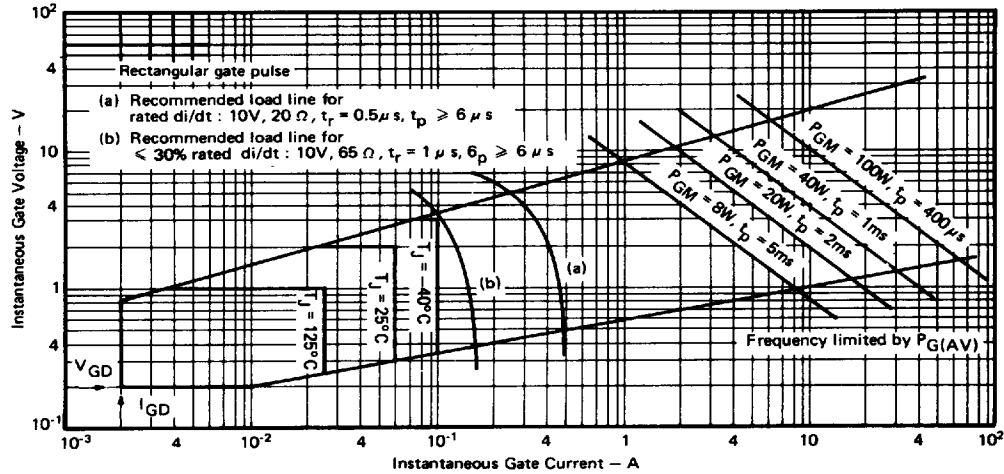

Fig. 25 - Gate Characteristics 22RIA Series

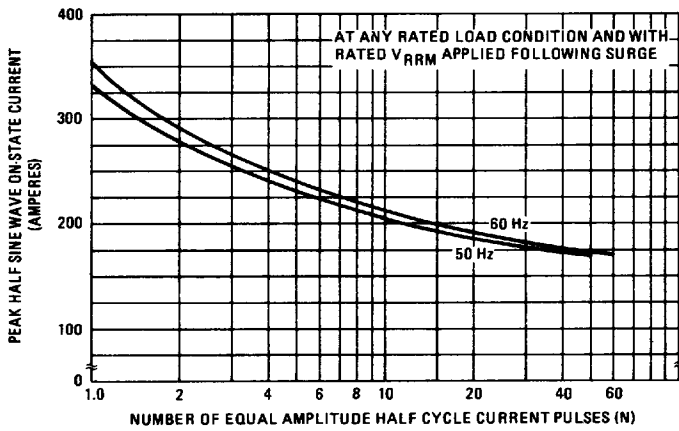

Fig. 26 - Maximum Non-Repetitive Surge Current Vs. Number of Current Pulses, 22RIA Series

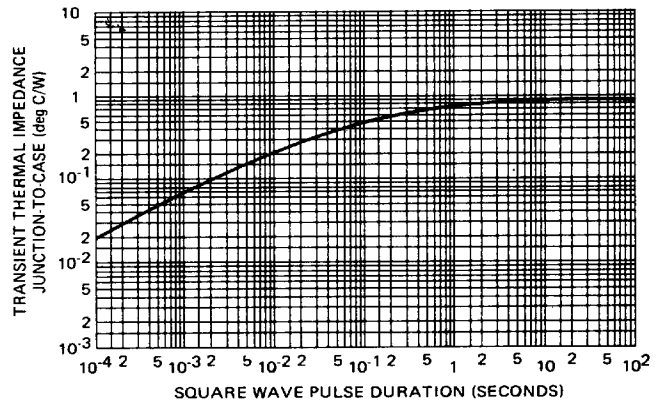

Fig. 27 - Maximum Transient Thermal Impedance, Junction-to-Case Vs. Pulse Duration, 22RIA Series

25RIA Series

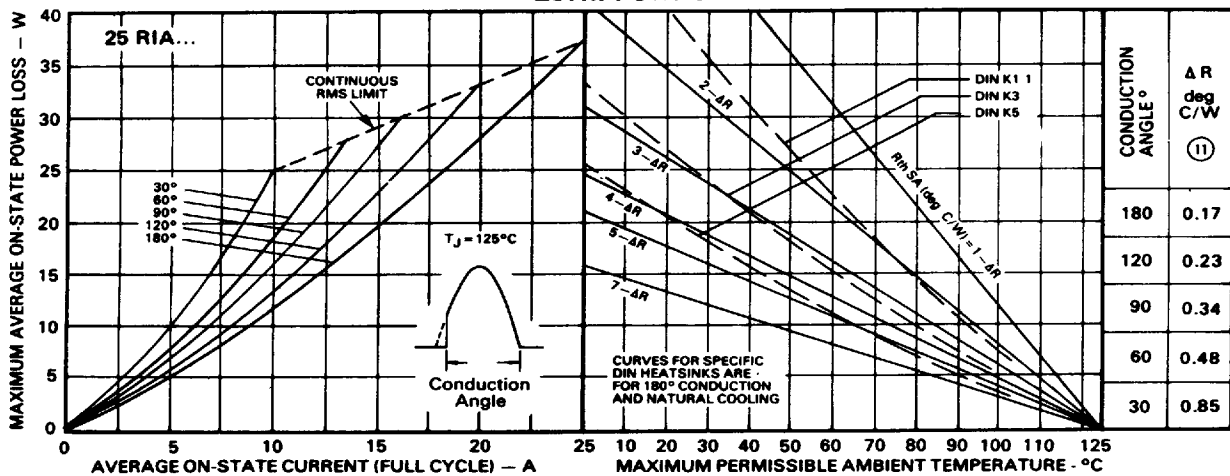
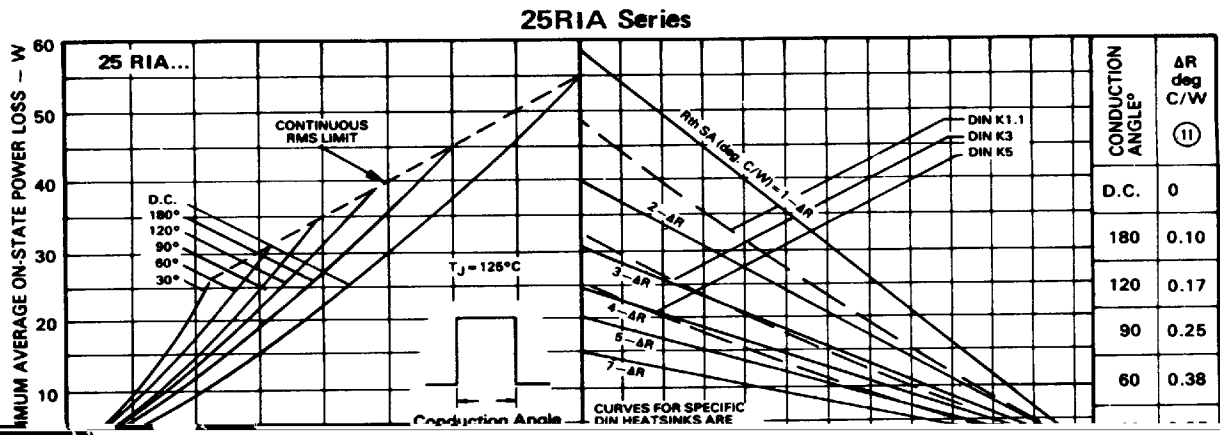

Fig. 28 - Continuous Current Rating Nomogram (Phase Angle Controlled Half-Sinusoidal Waveforms, 50-400 Hz), 25RIA Series.

12



25RIA Series

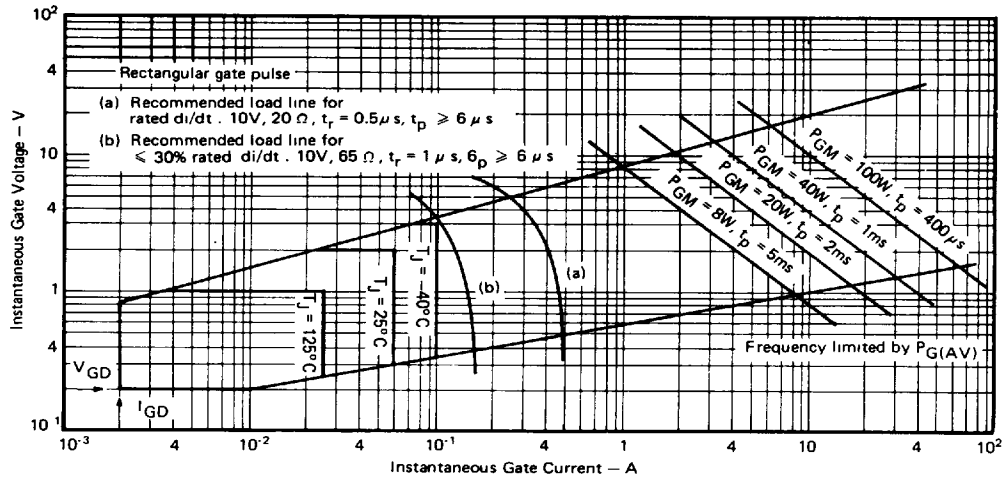

Fig. 34 - Gate Characteristics, 25RIA Series

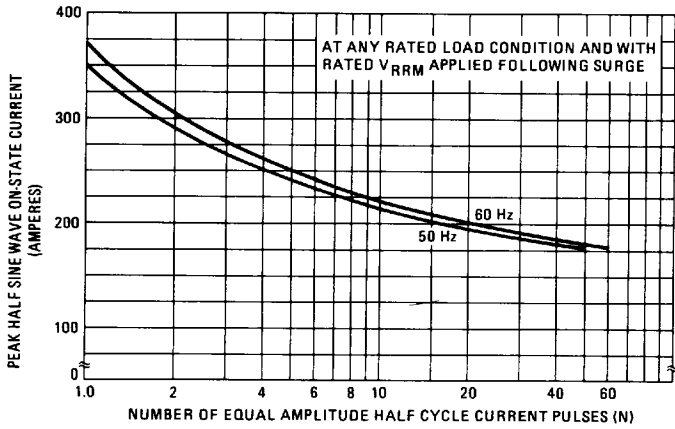

Fig. 35 - Maximum Non-Repetitive Surge Current Vs. Number of Current Pulses, 25RIA Series

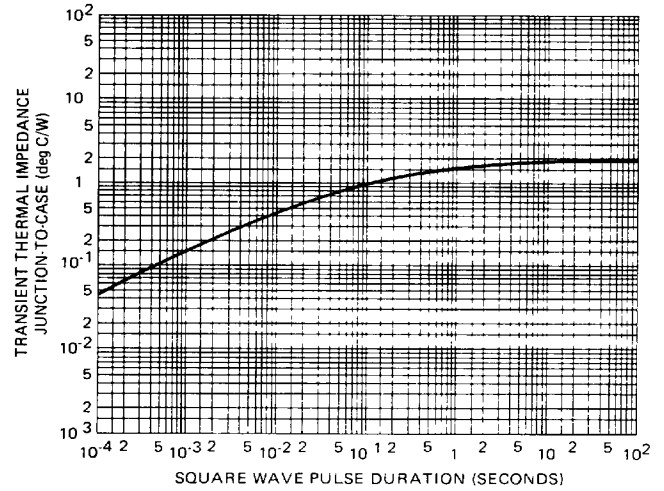

Fig. 36 - Maximum Transient Thermal Impedance, Junction-to-Case Vs. Pulse Duration, 25RIA Series

141