

# Spezifikation für Freigabe / specification for release

Kunde / customer :  
 Artikelnummer / part number : **749023020**  
 Bezeichnung : LAN-Übertrager WE-LAN  
 description : LAN-Transformer WE-LAN



**WÜRTH ELEKTRONIK**

DATUM / DATE : 2006-03-24

## A Mechanische Abmessungen / dimensions :

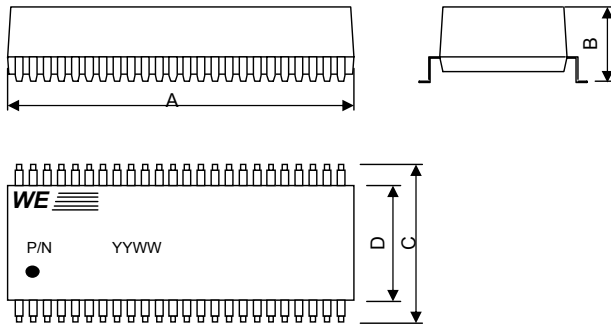

	1000 BaseT	
A	<b>27,81 ± 0,25</b>	mm
B	<b>7,24 ± 0,25</b>	mm
C	<b>16,00 ± 0,25</b>	mm
D	<b>12,20 ± 0,25</b>	mm

● = Pin 1

## B Elektrische Eigenschaften / electrical properties :

Eigenschaften / properties	Testbedingungen / test conditions		Wert / value	Einheit / unit	tol.
Induktivität / Inductance	<b>100kHz / 100mV @ 8mA DC Bias</b>	OCL	<b>350</b>	µH	min.
Übersetzungsverhältnis / Turns ratio	<b>100kHz / 100mV</b>	TR	<b>1 : 1</b>	Tx	<b>3%</b>
			<b>1 : 1</b>	Rx	
Insertion Loss	<b>0,1MHz</b>	IL	<b>-1,1</b>	dB	max.
	<b>100MHz</b>		<b>-1,0</b>		
	<b>125MHz</b>		<b>-2,0</b>		
Return Loss	<b>30MHz @ 100Ω</b>	RL	<b>-18</b>	dB	typ.
	<b>60MHz @ 100Ω</b>		<b>-12</b>		
	<b>80MHz @ 100Ω</b>		<b>-12</b>		
	<b>100MHz @ 100Ω</b>		<b>-10</b>		
Crosstalk	<b>30MHz</b>	DCMR	<b>-41</b>	dB	min.
	<b>60MHz</b>		<b>-37</b>		
	<b>100MHz</b>		<b>-33</b>		

## C Lötpad / soldering spec. :

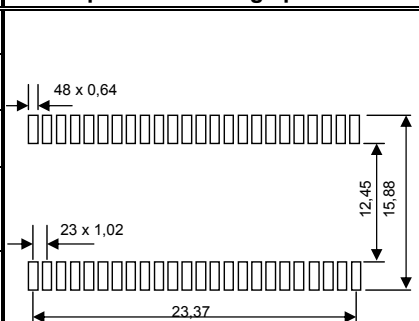

## D Prüfgeräte / test equipment :

HP4395A

## E Testbedingungen / test conditions :

Luftfeuchtigkeit / humidity: 33%  
 Umgebungstemperatur / temperature: +25°C

## F Werkstoffe & Zulassungen / material & approvals :

Basismaterial / base material:	Ferrit/ ferrite
Draht / wire:	4UEW 155°C
Kontaktmaterial/ contact plating	Cu-Ni-Sn
Gehäuse / case	UL94-V0
Verguss / potting	UL94-V0

## G Eigenschaften / general specifications :

Betriebstemp. / operating temperature: 0°C - + 70°C  
 Hochspannungsprüfung / Hipot test: 1500Vrms 1min.  
 geeignet für 1000BaseT-Anwendungen gemäß IEEE 802.3ab /  
 Compliant with IEEE 802.3ab for 1000BaseT  
 geeignet für Power over Ethernet-Anwendungen /  
 suitable for Power over Ethernet applications

Freigabe erteilt / general release:	<b>Kunde / customer</b>		
.....	.....		
Datum / date	<b>Unterschrift / signature</b>		
.....	<b>Würth Elektronik</b>		
.....	.....	TBr	Version 2 2006-03-24
.....	.....	TBr	Version 1 2006-01-31
Geprüft / checked	Kontrolliert / approved	Name	Änderung / modification Datum / date

## Würth Elektronik eiSos GmbH & Co.KG

D-74638 Waldenburg · Max-Eyth-Straße 1 - 3 · Germany · Telefon (+49) (0) 7942 - 945 - 0 · Telefax (+49) (0) 7942 - 945 - 400  
<http://www.we-online.com>

# Spezifikation für Freigabe / specification for release

Kunde / customer :  
 Artikelnummer / part number : **749023020**  
 Bezeichnung : **LAN-Übertrager WE-LAN**  
 description : **LAN-Transformer WE-LAN**

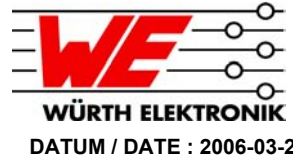

## H Schaltbild / Schematics :

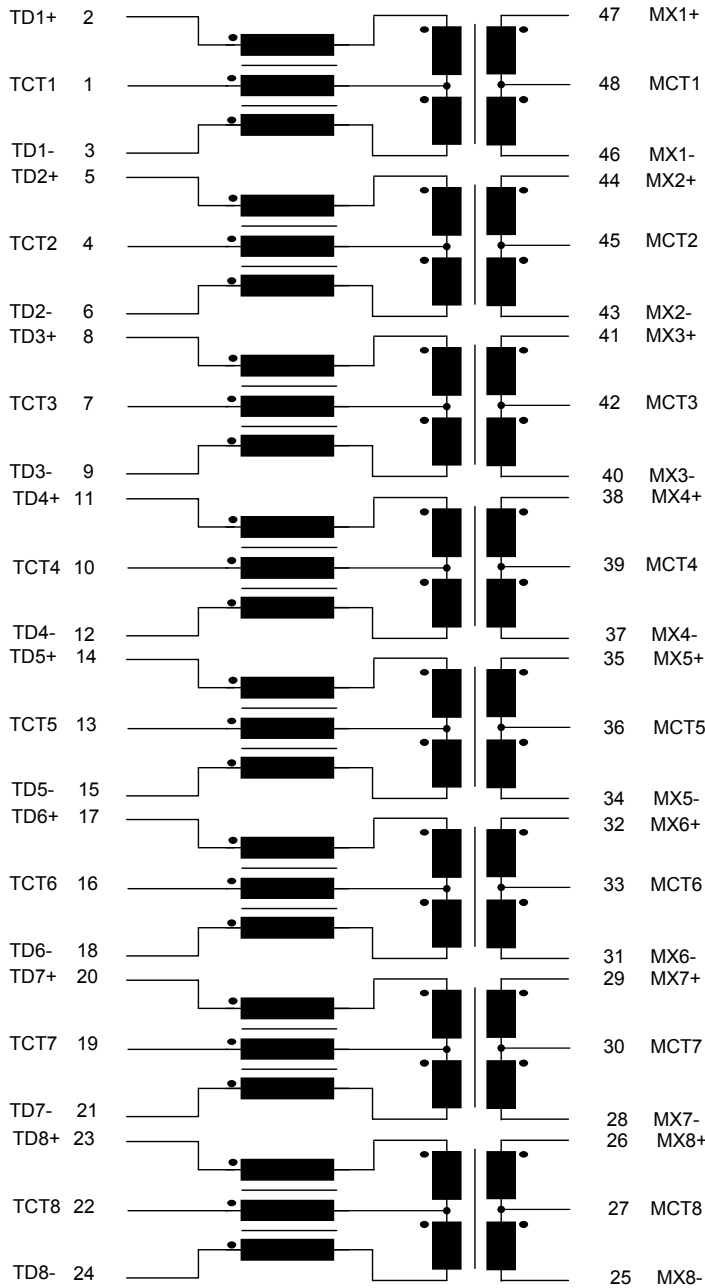

Freigabe erteilt / general release:	<b>Kunde / customer</b>			
..... Datum / date	..... Unterschrift / signature			
	<b>Würth Elektronik</b>			
..... Geprüft / checked	..... Kontrolliert / approved	Name	Änderung / modification	Datum / date
		TBr	Version 2	2006-03-24
		TBr	Version 1	2006-01-31

### Würth Elektronik eiSos GmbH & Co.KG

D-74638 Waldenburg · Max-Eyth-Straße 1 - 3 · Germany · Telefon (+49) (0) 7942 - 945 - 0 · Telefax (+49) (0) 7942 - 945 - 400  
<http://www.we-online.com>

# Spezifikation für Freigabe / specification for release

Kunde / customer :  
 Artikelnummer / part number : **749023020**  
 Bezeichnung : **LAN-Übertrager WE-LAN**  
 description : **LAN-Transformer WE-LAN**



**WÜRTH ELEKTRONIK**

DATUM / DATE : 2006-03-24

## I Rollenspezifikation / tape and reel specification :

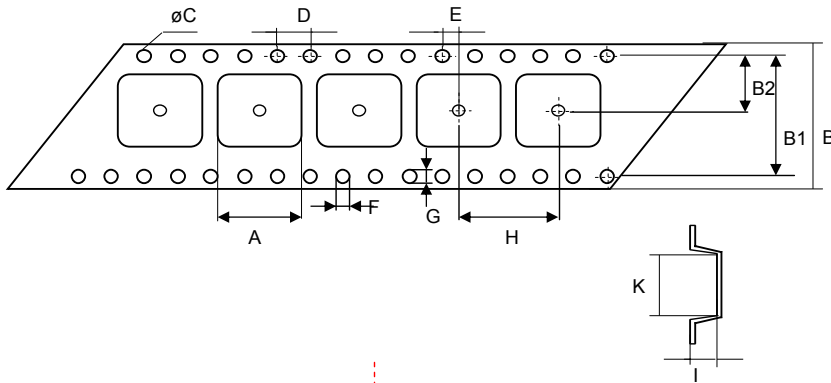

## Gurtspezifikation / Tape specification:

A	16,5 ± 0,1	mm
B	44,0 ± 0,3	mm
B1	40,4 ± 0,1	mm
B2	20,2 ± 0,1	mm
C	1,50 <sup>+0,1</sup> - 0,0	mm
D	4,00 ± 0,1	mm
E	2,00 ± 0,1	mm
F	1,50 <sup>+0,1</sup> - 0,0	mm
G	1,70 <sup>+0,15</sup> - 0,05	mm
H	24,0 ± 0,1	mm
I	6,5 ± 0,1	mm
K	18,5 ± 0,1	mm

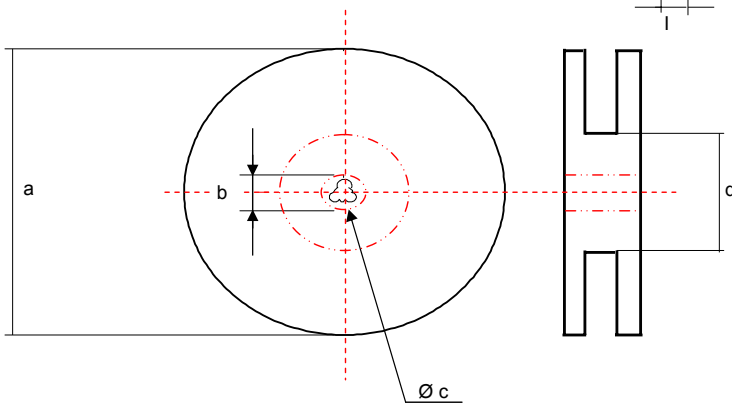

## Rollenspezifikation / Reel specification:

a	330,0 ± 2,0	mm
b	21,00 ± 0,8	mm
c	13,50 ± 0,5	mm
d	100,0 ± 1,0	mm

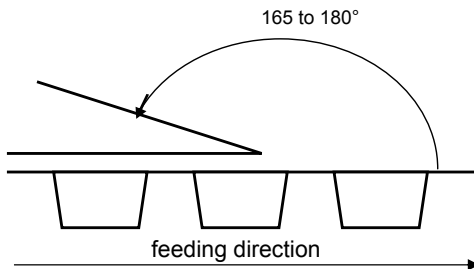

The force for tearing off cover tape is 10 to 130 grams in arrow direction

Freigabe erteilt / general release:

	<b>Kunde / customer</b>			
Datum / date	Unterschrift / signature			
	<b>Würth Elektronik</b>			
		TBr	Version 2	2006-03-24
		TBr	Version 1	2006-01-31
Geprüft / checked	Kontrolliert / approved	Name	Änderung / modification	Datum / date

This electronic component is designed and developed with the intention for use in general electronics equipments. Before incorporating the components into any equipments in the field such as aerospace, aviation, nuclear control, submarine, transportation, (automotive control, train control, ship control), transportation signal, disaster prevention, medical, public information network etc. where higher safety and reliability are especially required or if there is possibility of direct damage or injury to human body. In addition, even electronic component in general electronic equipments, when used in electrical circuits that require high safety, reliability functions or performance, the sufficient reliability evaluation-check for the safety must be performed before use. It is essential to give consideration when to install a protective circuit at the design stage.

## Würth Elektronik eiSos GmbH & Co.KG

D-74638 Waldenburg · Max-Eyth-Straße 1 - 3 · Germany · Telefon (+49) (0) 7942 - 945 - 0 · Telefax (+49) (0) 7942 - 945 - 400  
<http://www.we-online.com>