

### New Standard Series with 350-V Load Voltage

- Upgraded G3VM-2 Series.
- Continuous load current of 120 mA.
- Dielectric strength of 2,500 Vrms between I/O.
- Operating time of 0.3 ms (typical)

#### Application Examples

- Measurement devices
- Security systems
- Amusement machines

#### List of Models

Contact form	Terminals	Load voltage (peak value)	Model	Number per stick	Number per tape
SPST-NO	PCB terminals	350 VAC	G3VM-351A	100	---
	Surface-mounting terminals		G3VM-351D		
				G3VM-351D(TR)	

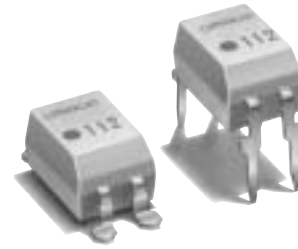

**NEW**

**Note:** The actual product is marked differently from the image shown here.

#### Dimensions

**Note:** All units are in millimeters unless otherwise indicated.

##### G3VM-351A

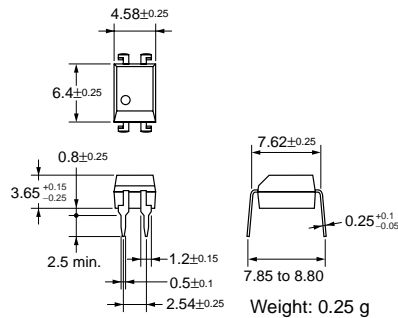

**Note:** The actual product is marked differently from the image shown here.

##### G3VM-351D

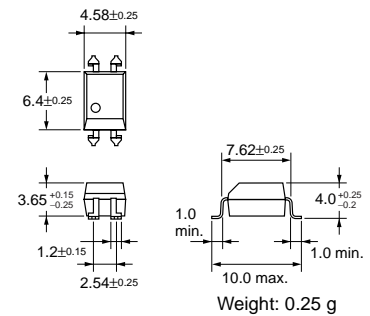

**Note:** The actual product is marked differently from the image shown here.

#### Terminal Arrangement/Internal Connections (Top View)

##### G3VM-351A

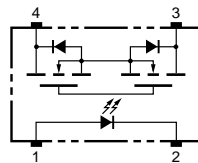

##### G3VM-351D

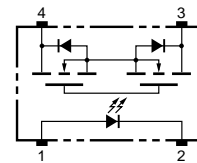

#### PCB Dimensions (Bottom View)

##### G3VM-351A

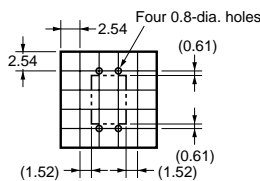

#### Actual Mounting Pad Dimensions (Recommended Value, Top View)

##### G3VM-351D

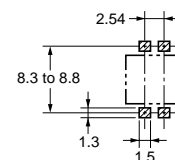

### Absolute Maximum Ratings (Ta = 25°C)

Item	Symbol	Rating	Unit	Measurement Conditions	
Input	LED forward current	$I_F$	50	mA	
	Repetitive peak LED forward current	$I_{FP}$	1	A	100 $\mu$ s pulses, 100 pps
	LED forward current reduction rate	$\Delta I_F/^\circ\text{C}$	-0.5	mA/°C	Ta $\geq$ 25°C
	LED reverse voltage	$V_R$	5	V	
	Connection temperature	$T_j$	125	°C	
Output	Output dielectric strength	$V_{OFF}$	350	V	
	Continuous load current	$I_O$	120	mA	
	ON current reduction rate	$\Delta I_{ON}/^\circ\text{C}$	-1.2	mA/°C	Ta $\geq$ 25°C
	Connection temperature	$T_j$	125	°C	
Dielectric strength between input and output (See note 1.)		$V_{I-O}$	2,500	Vrms	AC for 1 min
Operating temperature		$T_a$	-40 to +85	°C	With no icing or condensation
Storage temperature		$T_{stg}$	-55 to +125	°C	With no icing or condensation
Soldering temperature (10 s)		---	260	°C	10 s

**Note:** 1. The dielectric strength between the input and output was checked by applying voltage between all pins as a group on the LED side and all pins as a group on the light-receiving side.

### Electrical Characteristics (Ta = 25°C)

Item	Symbol	Minimum	Typical	Maximum	Unit	Measurement conditions	
Input	LED forward voltage	$V_F$	1.0	1.15	1.3	V	$I_F = 10$ mA
	Reverse current	$I_R$	---	---	10	$\mu$ A	$V_R = 5$ V
	Capacity between terminals	$C_T$	---	30	---	pF	V = 0, f = 1 MHz
	Trigger LED forward current	$I_{FT}$	---	1	3	mA	$I_O = 120$ mA
Output	Maximum resistance with output ON	$R_{ON}$	---	25	35	$\Omega$	$I_F = 5$ mA, $I_O = 120$ mA, t < 1 s
		---	---	35	50	$\Omega$	$I_F = 5$ mA, $I_O = 120$ mA
	Current leakage when the relay is open	$I_{LEAK}$	---	---	1.0	$\mu$ A	$V_{OFF} = 350$ V
Capacity between I/O terminals		$C_{I-O}$	---	0.8	---	pF	f = 1 MHz, Vs = 0 V
Insulation resistance		$R_{I-O}$	1,000	---	---	M $\Omega$	$V_{I-O} = 500$ VDC, RoH $\leq$ 60%
Turn-ON time		tON	---	0.3	1.0	ms	$I_F = 5$ mA, $R_L = 200$ $\Omega$ , $V_{DD} = 20$ V (See note 2.)
Turn-OFF time		tOFF	---	0.1	1.0	ms	

**Note:** 2. Turn-ON and Turn-OFF Times

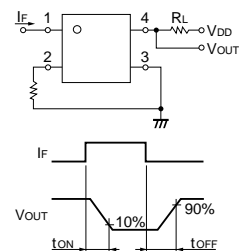

### Recommended Operating Conditions

Use the G3VM under the following conditions so that the Relay will operate properly.

Item	Symbol	Minimum	Typical	Maximum	Unit
Output dielectric strength	$V_{DD}$	---	---	280	V
Operating LED forward current	$I_F$	5	7.5	25	mA
Continuous load current	$I_O$	---	---	100	mA
Operating temperature	$T_a$	-20	---	65	°C

### Engineering Data

#### Load Current vs. Ambient Temperature G3VM-351A(D)

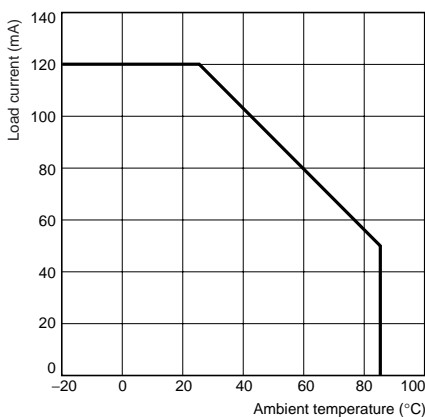

### Safety Precautions

Refer to page 6 for precautions common to all G3VM models.