



STAINLESS STEEL KEYPADS AND KEYBOARDS

Stainless steel keypads and keyboards are particularly resistant to harsh environments: extreme climatic conditions, vandalism, stains... They consist of customised stainless steel single keys mounted in a front face.

APEM develops and sells five series meeting EMC international standards and featuring good tactile feedback and IP65 front face sealing. Technology and key shape make the difference between the series.

Advantages

7 AND 70 SERIES for semi-protected environment

7 series

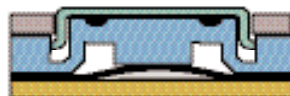

Stainless steel keys and front face
Rubber keypad
Printed circuit
Stainless steel dome

- Oblong keys
- Laser marking
- PS2-USB interface

70 series

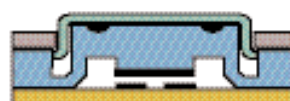

Stainless steel keys and front face
Rubber keypad
Printed circuit
Carbon contact

- Long-travel keys (rapid data entry)
- Laser marking
- PS2-USB interface

8P AND 8Z SERIES for semi-protected environment

8P series

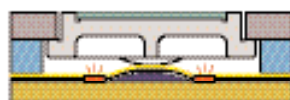

Stainless steel front face
Stainless keys on support
Silicone film
Printed circuit
Stainless steel dome

- Backlighting
- Modularity
- Compact construction: 16.5 mm min. key spacing
- Laser marking or chemical etching

8Z series

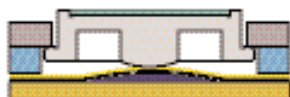

- Prominent keys
- Modularity
- Encryption option
- Laser marking or chemical etching

9 SERIES for external environments

9 series

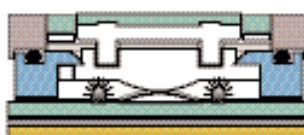

Stainless steel keys and front face
Silicone film
Printed circuit
Stainless steel dome

- For harsh environments
- Backlighting
- Modularity
- Chemical etching
- Encryption option

mechanical specifications

Contact force:	0.4 N +/- 0.5 N
Contact travel:	0.5 mm
Operations:	1 000 000
Sealing:	IP 65
Track ball:	IP 65 static

electrical specifications

Maximum voltage:	24 VDC
Maximum current:	50 mA
Contact resistance:	< 10 ohms
Dielectric strength:	250 V
Insulation resistance:	> 100 M ohms

mechanical specifications

Contact force:	1.5 N +/- 20 %
Contact travel:	1.3 mm
Operations:	1 000 000
Sealing:	IP 65
Track ball:	IP 65 static

electrical specifications

Maximum voltage:	12 VDC
Maximum current:	10 mA
Contact resistance:	8 to 20 ohms
Dielectric strength:	250 V
Insulation resistance:	> 100 M ohms

mechanical specifications

Contact force:	0.4 N +/- 0.5 N
Contact travel:	0.5 mm
Operations:	1 000 000
Sealing:	IP 65
Track ball:	IP 65 static

electrical specifications

Maximum voltage:	24 VDC
Maximum current:	50 mA
Contact resistance:	< 10 ohms
Dielectric strength:	250 V
Insulation resistance:	> 100 M ohms

mechanical specifications

Contact force:	2.5 to 4 N +/- 0.5 N
Contact travel:	0.5 mm
Operations:	3 000 000
Sealing:	IP 65
Track ball:	IP 65 static

electrical specifications

Maximum voltage:	24 VDC
Maximum current:	50 mA
Contact resistance:	< 10 ohms
Dielectric strength:	250 V
Insulation resistance:	> 100 M ohms

Climatic specifications for all types

Operating temperature:	- 20° / + 70°C
With standard interface:	0° / + 70°C
With specific interface:	- 20° / + 70°C
Storage temperature:	- 40° / + 85°C

STAINLESS STEEL KEYPADS AND KEYBOARDS



Numerous configurations

The five series offered by APEM not only meet the needs for standard keypads and keyboards, but also the needs for customised products with specific number of keys and key layout. Depending on the series, standard keys differ in shape and dimension; in all cases, custom marking is available. The APEM range also includes stainless steel keypads and keyboards with backlighting by LED's.

KEY SHAPES

7 series - 70 series
Oblong



8 series - 9 series
Round, square, rectangular



KEY MARKING

7 series - 70 series
Laser marking



8 series - 9 series
Chemical etching (colours available)



BACKLIGHTING

8 series - 9 series

By LED (white, red, green, yellow, blue)

Supply voltage: + 5, + 12, + 24 VDC
Max. current for a backlit key:
8 series: 10 to 40 mA
9 series: 10 to 20 mA
depending on LED colour, number of LED's and supply voltage.

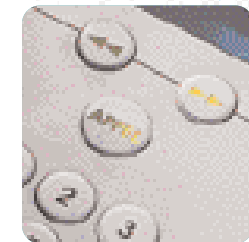

MODULARITY

8 series - 9 series

From standard keys, APEM can develop specific keypads and keyboards without expensive tooling costs for the customer.



Cut-Out 82,5 x 63,5 R=2.25

Panel thickness = 2 mm

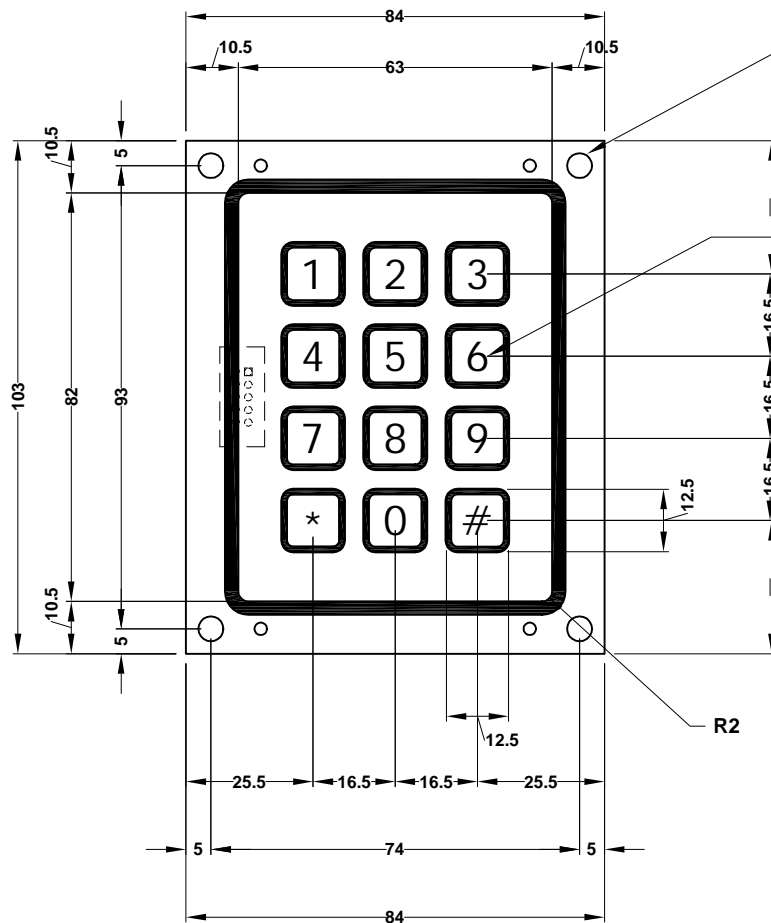

N° 4 fixing holes Ø5 mm

Keys marking black colour

(CN1) 10 Pins ribbon plug connector (3 x 4 Output matrix)

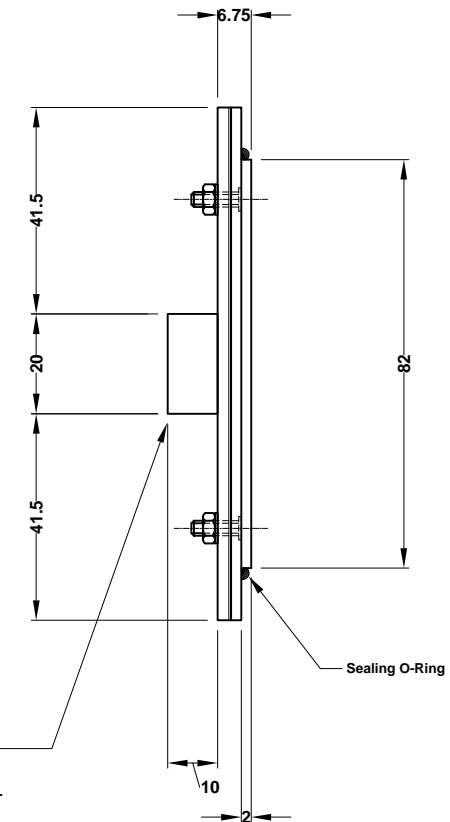

Sealing O-Ring

TOP SIDE

THIS DRAW IS A RESERVED PROPERTY OF APEM ITALIA S.r.l.		ALL DIMENSIONS IN mm UNLESS OTHERWISE STATED - DO NOT SCALE DRAWING -		TOLERANCES UNLESS OTHERWISE STATED		LINEAR ±0.1 mm ANGULAR ±30'	
REPRODUCTION FORBIDDEN	DATA	SIGNATURE		DESCRIPTION			
DRAWN	15/04/2004	P. Mollo		T12PQR ASSEMBLY			
CHECKED		xxxxxx					
APPROVED		xxxxxx					
PART. N. 59800013		SCALE	1 : 1	REV. 0			
59800013 .DWG		SHEET	INDEX REF.	OF			
		1 / 1					

1	xxxxxxx	///////	⚠	///////	
Rev.	DATE	Signature	Description of modifications	Approved	



APEM ITALIA S.r.l.
via G. Marconi 147/G
12030 MARENE (CN) - ITALIA
Tel. +39.0172.743170
Fax. +39.0172.743171
apem.italia@apem.it
www.apem.it