

**MELSEC
FX0S,
FX0N,
FX2N**

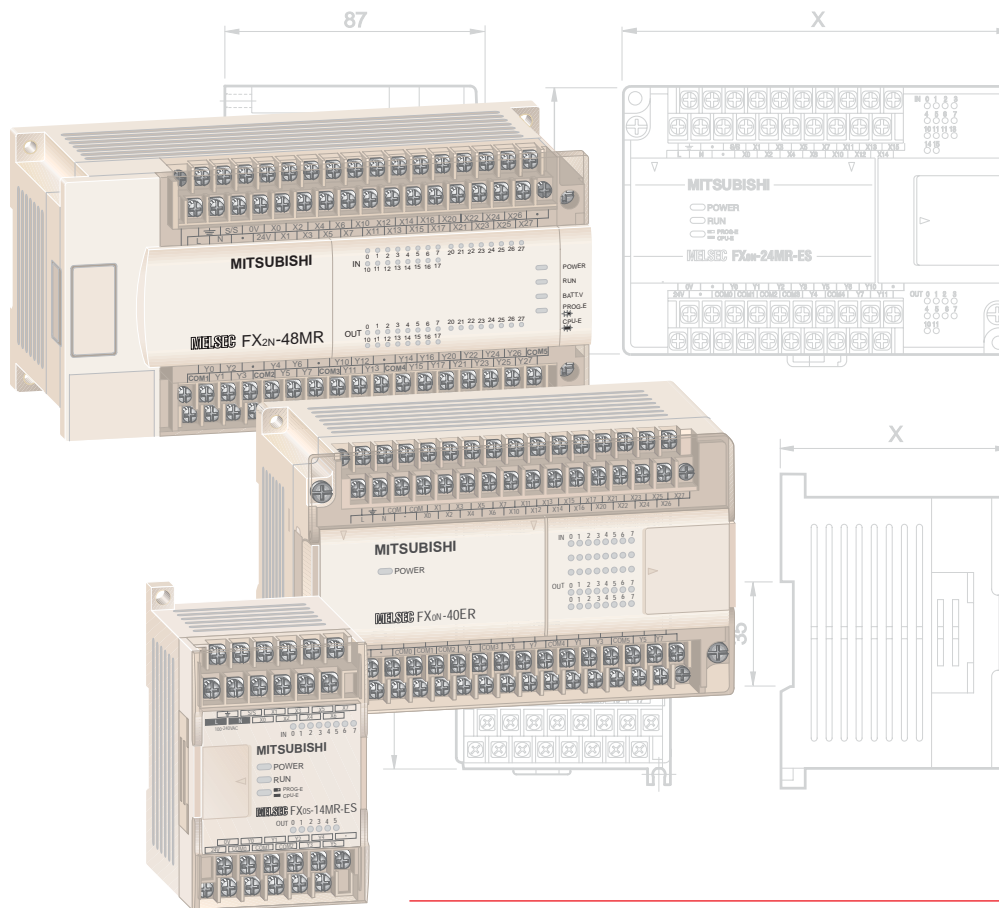

Technical Catalogue



New Items in this Catalogue

**New Products
1998**



MELSEC FX_{0N}

Integration of the new FX_{2N} extension modules and special function modules for the FX_{0N} series



MELSEC FX_{2N}

The consistent advancement of the proven FX to the FX_{2N}



Accessories

Simulation strip for the simulation of digital inputs, Profibus plug



Programming

MX-Scada: process supervision software
ProfiMap: Profibus configuration software

Further Publications within the PLC Range

**Technical
Catalogues**



AnA, AnN, AnU, QnA Series Technical Catalogue

Product catalogue for programmable logic controllers and accessories for the MELSEC A and Q series (art no. 61747)



QnAS, AnS Series Technical Catalogue

Product catalogue for programmable logic controllers and accessories for the MELSEC AnS and QnAS series (art. no. 59085)



HMI Technical Catalogue

Product catalogue for operator terminals, supervision software and accessories (art. no. 68542)



About this product catalogue

Texts, figures and diagrams shown in this product catalogue are intended exclusively for explanation and assistance in planning and ordering the programmable logic controllers of the MELSEC FX_{0S}, FX_{0N} and FX_{2N} series and the associated accessories. Only the manuals supplied with the modules are relevant for installation, commissioning and handling of the controllers and the accessories. The information given in this documentation must be read before installation and commissioning of the modules.

Should questions arise with regard to the planning of modules described in this product catalogue, do not hesitate to contact the german branch of the MITSUBISHI ELECTRIC EUROPE B.V. in Ratingen or one of its distributors (see cover page).

No parts of this product catalogue may be duplicated, stored in an information system or transmitted without prior express written permission from MITSUBISHI ELECTRIC EUROPE B.V..

© MITSUBISHI ELECTRIC EUROPE B.V. 12/1998 (2nd issue)

FX FAMILY

SYSTEM DESCRIPTION

- ◆ Introduction of the FX family 4
- ◆ Networks 8



MELSEC FX0S

BASE UNITS

- ◆ Description of system and unit 10
- ◆ Specifications 12

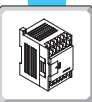

ACCESSORIES

- ◆ Simulation strip, simulation box 14
- ◆ Program loader 15



TERMINALS AND DIMENSIONS

- ◆ Terminal assignments 16
- ◆ Dimensions 17



MELSEC FX0N/FX2N

SYSTEM DESCRIPTION

- ◆ Base units 18
- ◆ Extension and special function modules 22
- ◆ System specifications 25

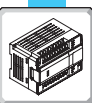

BASE UNITS

- ◆ Specifications FX0N 26
- ◆ Specifications FX2N 28

EXTENSION UNITS

- ◆ Compact extension units 32
- ◆ Modular extension units 34



SPECIAL FUNCTION UNITS

- ◆ Analog modules 36
- ◆ Counter and positioning module 39
- ◆ Interface module 40
- ◆ Communications modules 42

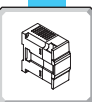

ACCESSORIES

- ◆ Memory cassettes and interface converter 52
- ◆ PROM adapter, simulation box and simulation strip 53
- ◆ Batteries and connection cables 54



TERMINALS AND DIMENSIONS

- ◆ Terminal assignments of the base units 56
- ◆ Terminal assignments of the extension units 60
- ◆ Terminal assignments of the special function units 63
- ◆ Dimensions 66



PROGRAMMING

PROGRAMMING UNITS AND SOFTWARE

- ◆ Software 70
- ◆ Hand-held programming units, cables and EPROM writer 72

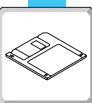

APPENDIX

- ◆ Order form 74
- ◆ Index 75

The MELSEC FX Family

Description

The MELSEC FX family includes a very comprehensive range of base and expansion modules, enabling you to configure a customised system tailored to your precise requirements.

Depending on your application and control needs you can choose from the small, attractively-priced, "stand-alone" MELSEC FX0s series, the expandable FX0N series or the more powerful FX2N series.

The FX0N and FX2N series are both a good choice for plant installations because their expansion options enable them to grow with the needs of your application. Network integration is also supported, making it possible for your FX controllers to communicate with other PLCs, controllers and MMIs. The PLC systems can be configured as local stations in MITSUBISHI networks (MELSECNET/MINI), and as slave stations in open networks (PROFIBUS/DP).

In addition to this, the controllers of the MELSEC FX0N/FX2N series also support integration in multidrop and peer-to-peer network configurations.

All FX systems are members of the great MELSEC family of PLCs, in which all systems are compatible with one another.

Special features:

- Expandable from 10 – 256 I/Os
- Compact, robust design
- Extensive communications support
- Simple installation
- Custom configuration for the needs of existing systems
- Innovative, "future-proof" technology protects your investment
- Worldwide standards
- Quality products manufactured in facilities with ISO 9001 certified quality management systems and subject to special manufacturers' standards

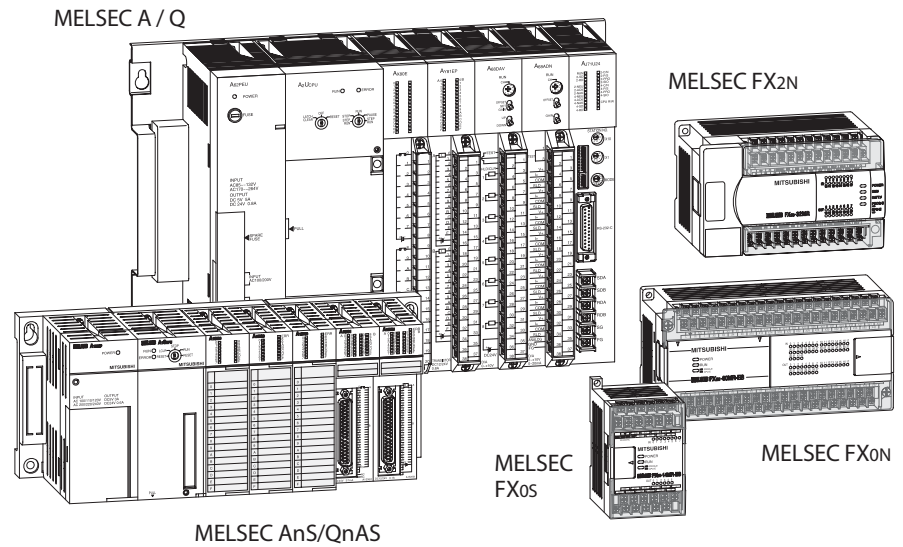

Expandability and power

The MELSEC FX family is highly flexible, enabling fast and efficient configuration and programming for the application at hand.

It is the ideal choice, no matter whether you need to install a simple control application requiring up to 30 I/Os (FX0s) or a demanding, complex system with up to 256 I/O points (FX2N).

The capacity of the CPUs of the FX0N/FX2N series can be expanded with memory cassettes. Non-volatile memory cassettes with a capacity of up to 16K program steps are available for reliable, long-term storage of your PLC projects. In addition to the other advantages this enables you to switch programs at very short notice, simply by replacing a cassette.

There are three series in the MELSEC FX family, each of which is designed for a different application profile:

● The FX0s series

The MELSEC FX0s series is the inexpensive entry to the MELSEC FX family. With its small dimensions it is also an excellent alternative to relay/contactor control configurations.

● The FX0N series

The CPUs of the FX0N series offer more power than the FX0s series, plus modular expansion capabilities. You can choose from I/O expansion modules and special function modules for a wide variety of applications.

● The FX2N series

The new FX2N series complements the existing FX family and replaces the successful FX series. It gives you the freedom of modular expandability, with a wide selection of expansion modules and special function modules. The FX2N is also one of the fastest PLC systems available, with a

cycle time of just 0,08 µs per logical instruction.

Thus the FX2N series gives you the most powerful CPU for your application and combines all benefits of a compact PLC system with the performance of a modular PLC system.

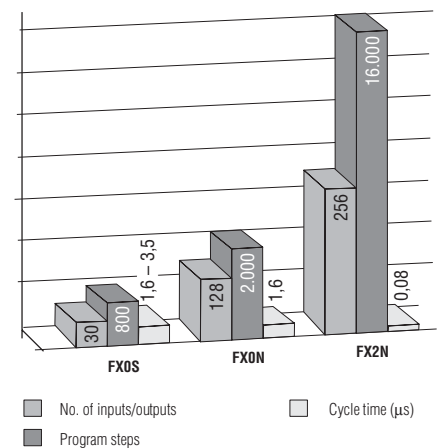

Features

The modular design of the FX0N/FX2N series makes it extremely flexible, enabling it to be used for a very broad range of applications.

You can configure tailor-made systems by combining modules from a variety of different categories (see figure).

All modules are electrically isolated from their environment with optocouplers for maximum reliability.

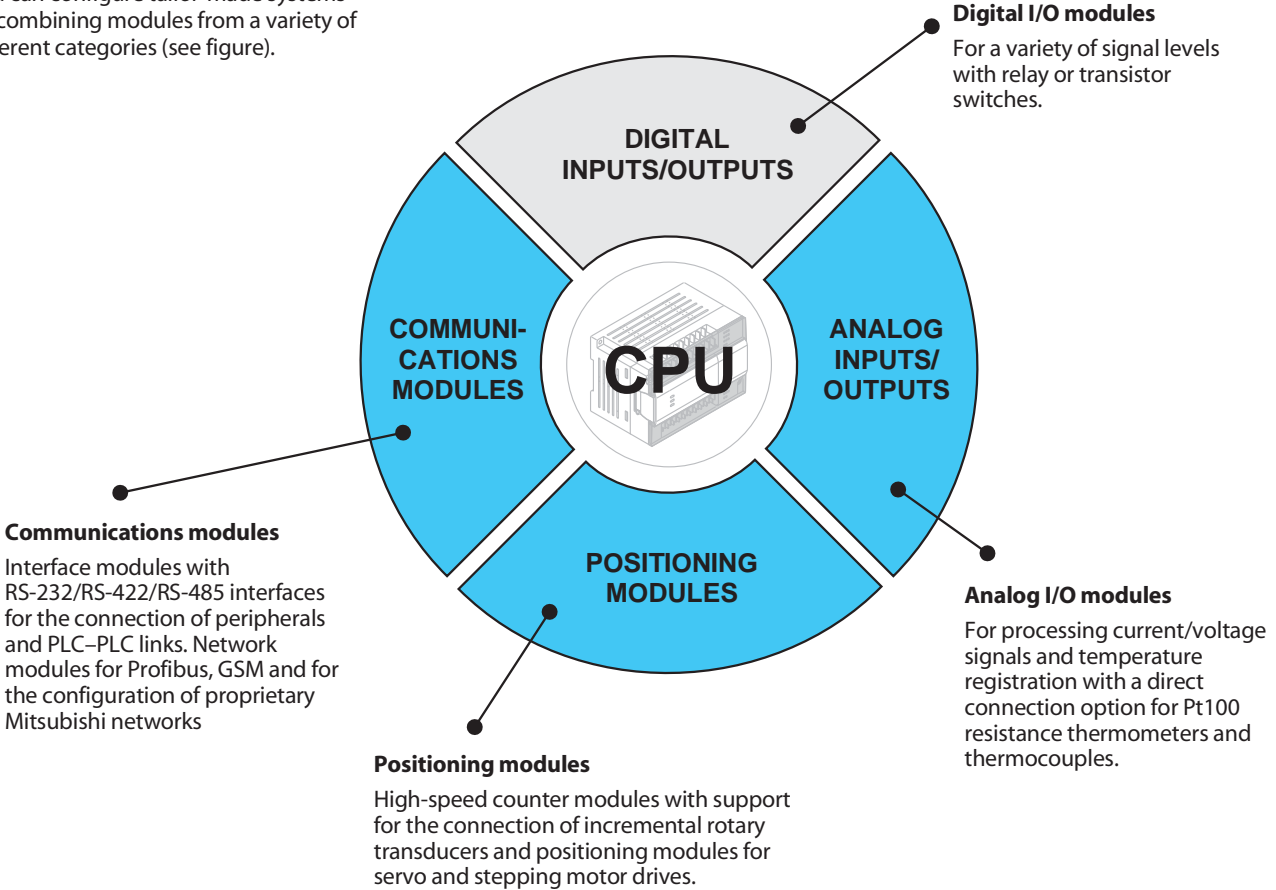

Digital and special function modules – configuration

The options for using digital and special function modules are dictated by CPU used in the system.

When calculating the number of special function modules you can use in a system you must take both the number of digital modules and the maximum number of special function modules that can be used into account.

The table on the right provides a simplified guide to the number of modules you can use in each system type. More detailed information and the basic principles of system configuration can be found on page 21 ff.

CPU type	System restrictions
FX0S	Stand-alone PLC with 10 / 14 / 20 or 30 I/Os; no special function modules
FX0N	PLC with max. 128 I/Os; max. 2 special function modules supported
FX2N	PLC with max. 256 I/Os; max. 8 special function modules



Handling

Installation

Handling and installation of the modules are very simple.

All modules are fitted with an integrated DIN adapter for snap-on installation on DIN rail systems.

If you wish, the modules can also be installed normally on flat surfaces with screw fastenings.

In the FX0N and FX2N series all connections between the CPU's system bus and the expansion and special function modules are made with the standard flat ribbon cable. No other internal system wiring is required for connecting the CPU and modules.

Wiring

All external wiring is connected to the standard cable terminals to the screw terminals on the modules. The entire terminal block has a cover which provides protection against short circuits and inadvertent contact.

Programming

All CPUs have a standardised programming interface for connection of a programming unit or a personal computer.

Simple control tasks can be programmed directly using hand-held programming units or the control units of the FX-DU series. In addition to this the CPUs can also be programmed with the MELSEC MEDOC *plus* software package, which runs on a normal PC. This powerful programming environment can be used to create large application programs conforming to the IEC 1131.3 standard.

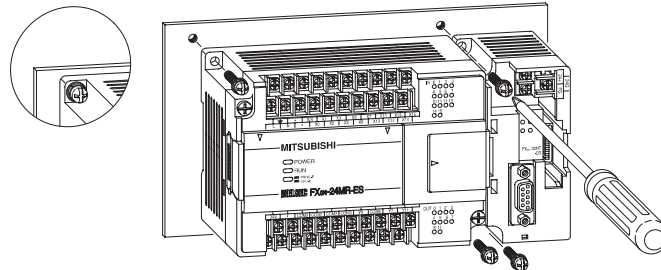
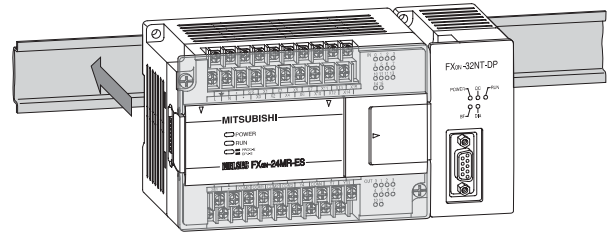
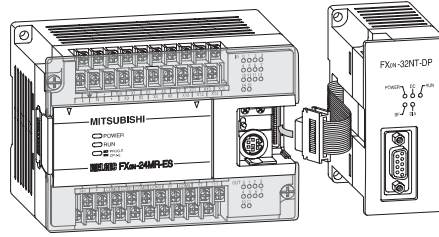

Multi-functional interfaces

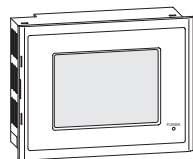
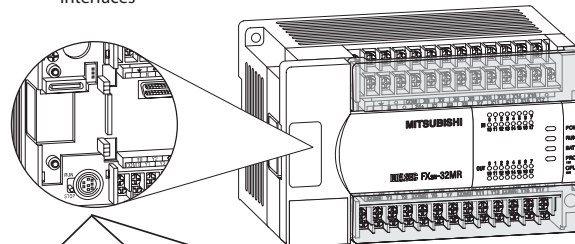

Graphic operator terminal



Hand-held programming unit

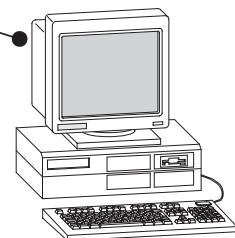

PC with programming and process supervision software



Process visualisation

For more effective supervision of machines and processes you can configure a process visualisation system as a hardware or software solution with partial or full graphical support. Process visualisation products available from Mitsubishi include a variety of different operator terminals and the powerful MX-SCADA process visualisation software package.

Peripherals

Separate interface modules enable the connection of output devices such as printers and also a variety of input devices such as barcode readers. Optional plug-in interfaces support the connection of additional programming or operator terminals, as well as the realization of various serial links.

A range of special communications modules are also available for integration of your PLC systems in a variety of networks.

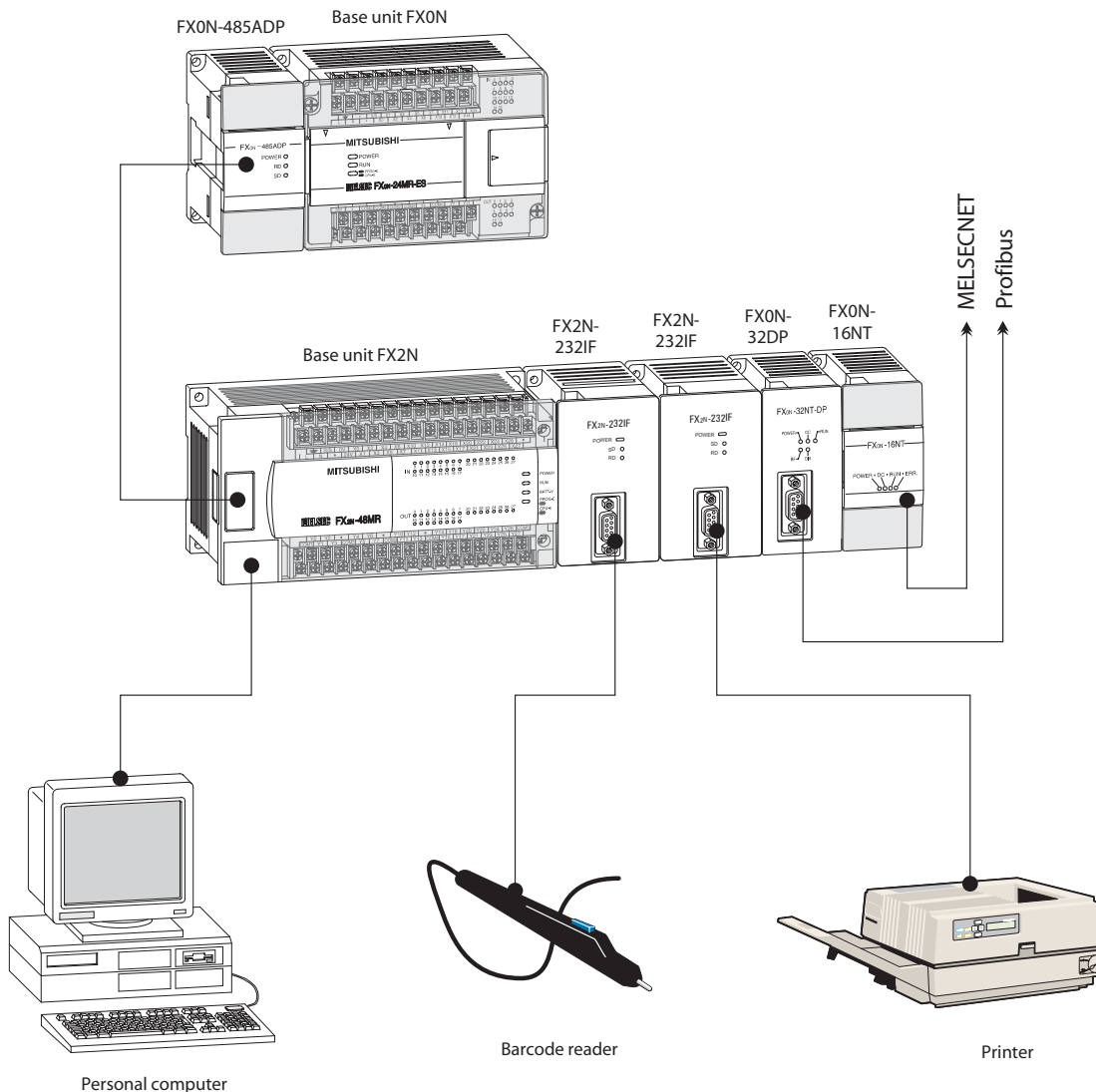
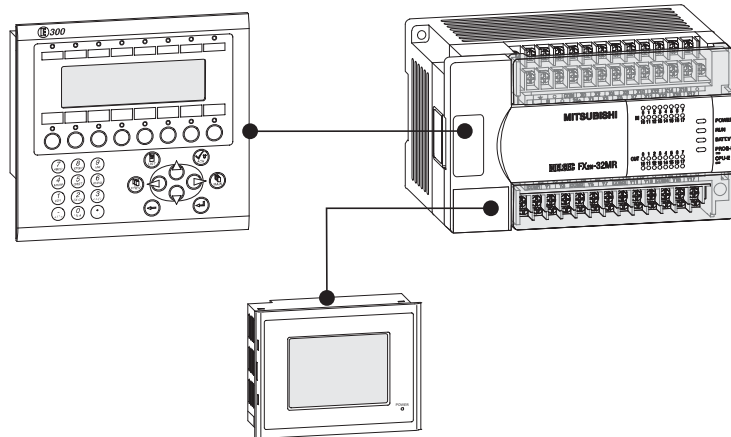

MELSEC Networks

TCP/IP ETHERNET

Ready for immediate operation with the worldwide standard TCP/IP protocol. A PC connected to the Ethernet has full access to all PLCs in the MELSECNET, all the way down to the I/Os on the production level.

MELSECNET/10 und -NET(II)

Low-cost cabling, brilliantly simple set-up and maximum availability thanks to redundancy and Floating Master. The max. coverage is up to 30 km.

MELSECNET/B

A cost-effective alternative within the production level. Enables implementation of easily-manageable configurations for complex applications by means of distributed intelligence.

MELSECNET/MINI-S3 MELSEC I/O-LINK

Enables decentralised configurations by linking remote modules to the machine. Integration of devices from other manu-

facturers is also possible. Any twisted-pair cabling can be used as the communications media.

MELSEC I/O LINK as a tree structure.

MELSEC FX Peer-to-Peer

The PPN construction enables a network for up to 8 FX2N and FX0N controllers as clients.

The max. coverage is up to 500 m. A standard twisted-pair cable can be used as the communications media.

COMMAND LEVEL

TCP/IP ETHERNET

CONTROL LEVEL

MELSECNET/10
MELSECNET(II)
MELSECNET/B

PRODUCTION LEVEL

MELSECNET/MINI-S3
MELSEC I/O-LINK
MELSEC FX PPN

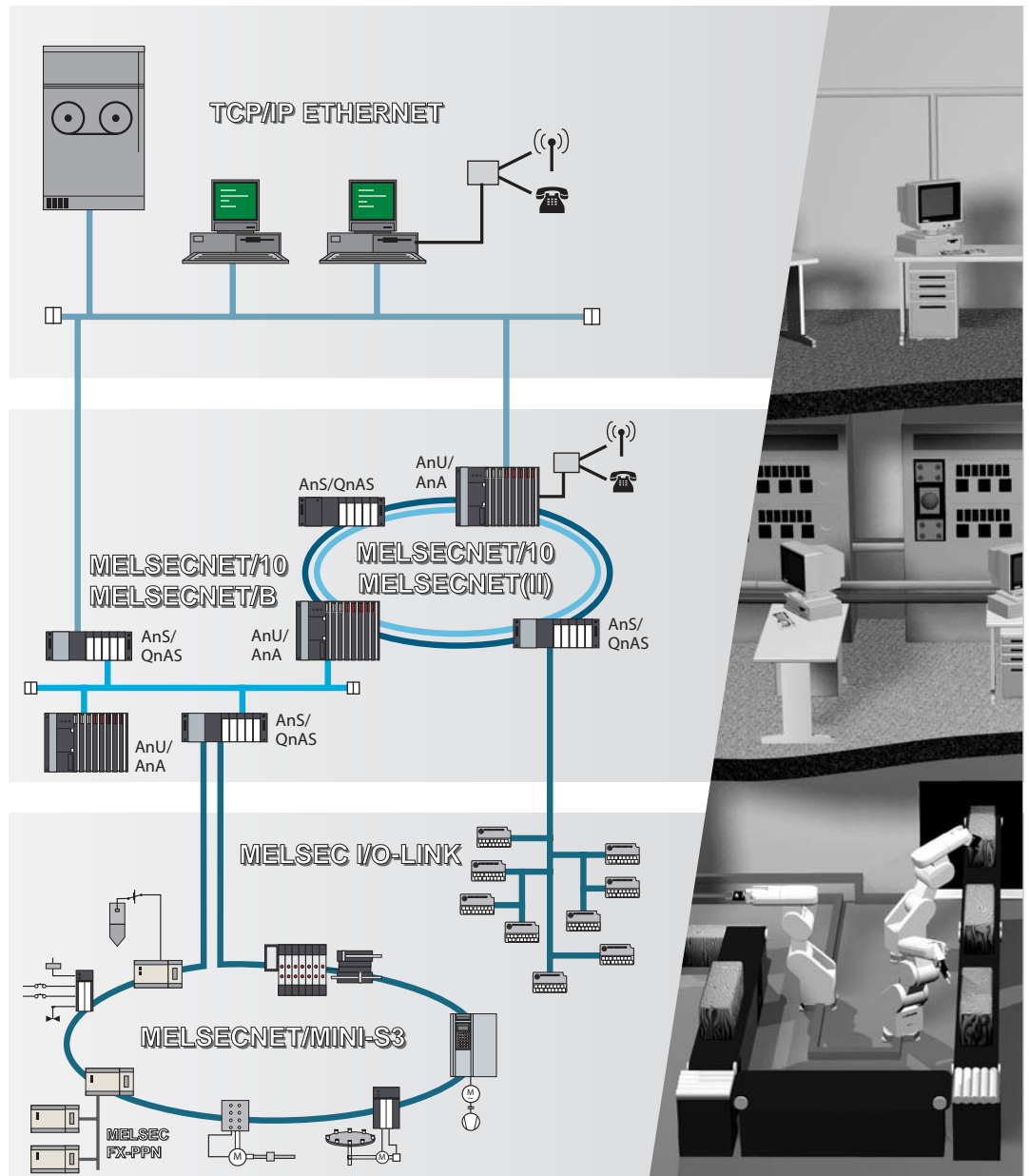

Open Networks

MAP 3.0 ETHERNET

Interdepartmental data exchange between the command and production levels using a non-proprietary protocol with short throughput times.

Profibus FMS

Communication between equipment from different manufacturers within a single plant. Automatic data exchange with MELSEC networks.

Profibus DP

Enables quick and simple connection of sensors and actuators from different manufacturers to MELSEC PLCs, with data transfer rates of up to 12 Mbaud.



COMMAND LEVEL
MAP 3.0 ETHERNET

CONTROL LEVEL
Profibus FMS

PRODUCTION LEVEL
Profibus DP

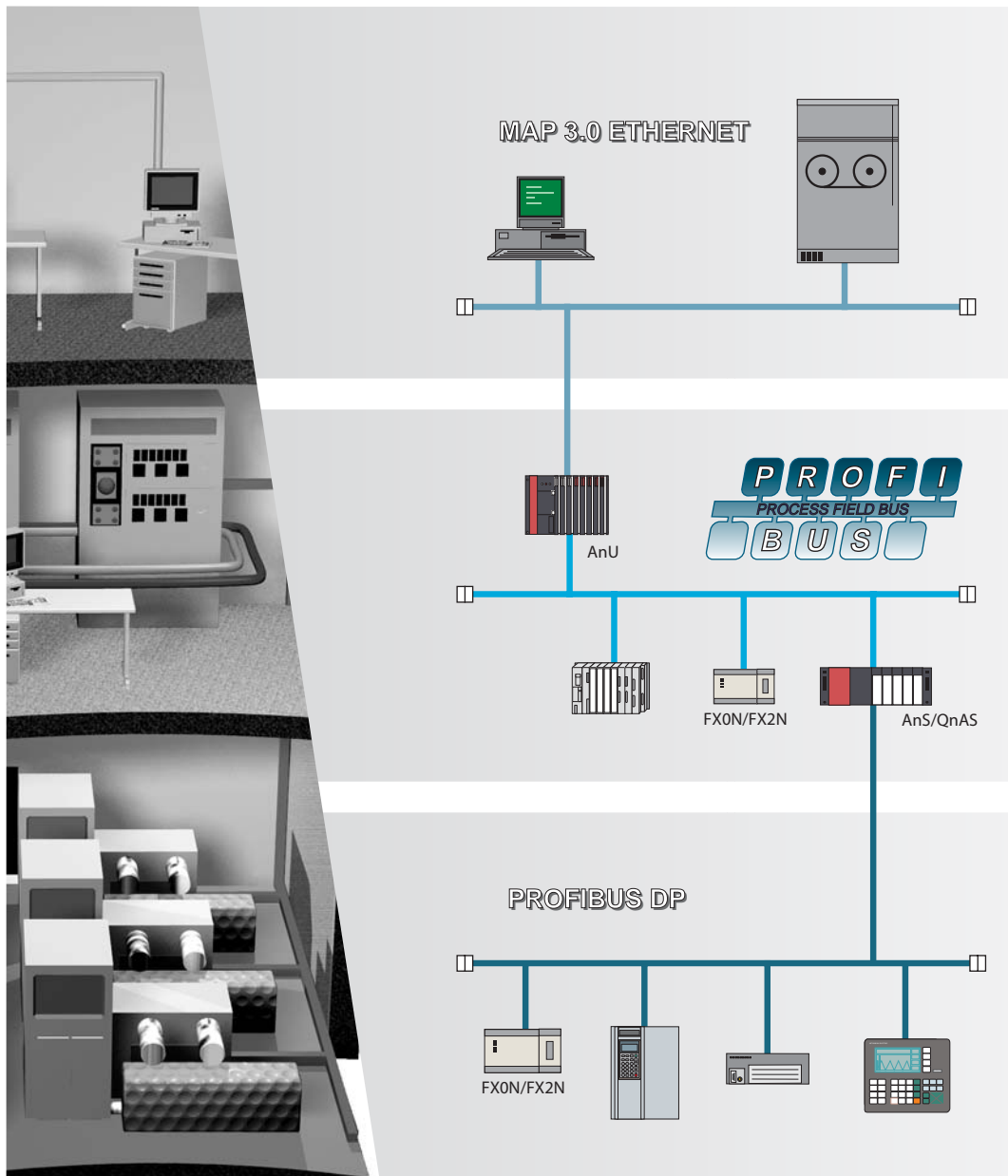

The MELSEC FX0s Series

Description

- Small
- Fast
- Versatile

The MELSEC FX0s is the cost-effective entry to the MELSEC family. It combines all the advantages of a PLC system in a very compact package, providing a space- and cost-saving alternative to relay/contacter control systems.

System structure

- Base unit with full PLC functionality
- Integrated power supply unit
- CPU
- Maintenance-free EEPROM memory
- Integrated digital inputs and outputs
- User-friendly programming systems, including hand-held programming units, IEC 1131.3-compatible programming software and MMIs
- Accessories

Equipment features

Base units are available in a number of versions with different power supply and output type configurations. You can choose between units with 230 V AC or 24 V DC power supplies and relay or transistor outputs.

All the base unit versions have the same basic CPU and performance specifications.

All units feature an **analog potentiometer** for setpoint value entry and an integrated RUN/STOP switch.

High-speed inputs for fast counting tasks with counting frequencies of up to 7 kHz and **interrupt processing capabilities**.

The **internal service power supply unit** for 24 V DC has a capacity of 200 mA.

Integrated serial interface for direct communication with computers.

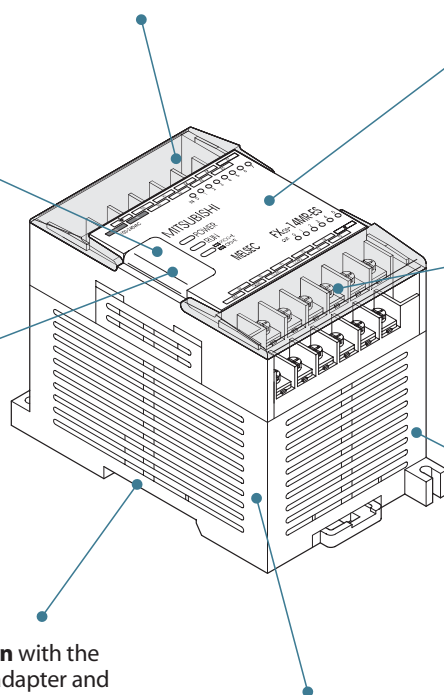

Square pulse output
Integrated pulse outputs for frequencies from 10 to 2000 Hz for controlling stepping motors and outputting **pulse-width modulated signals**.

Flexible installation with the integrated DIN rail adapter and screw fastening hose for mounting on flat surfaces.

Your PLC programs are stored in a maintenance-free **EEPROM user memory** with a capacity of 800 program steps and a backup battery to protect against power failures.

Password access protection facility for effective protection of your intellectual property.

Description of the Unit

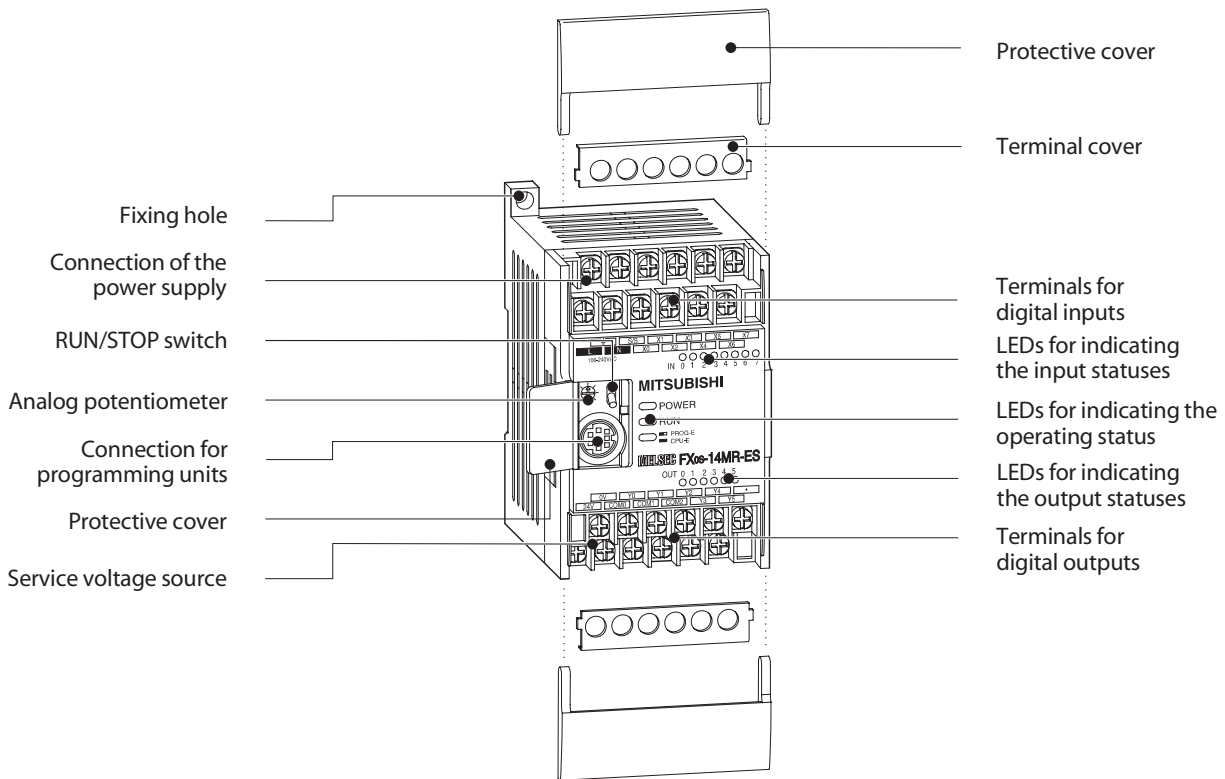

Reference Table for Model Designation Code

FX□□	-	14	M	R	E	S	UL
1	2	3	4	5a	5b	6	

The code in detail:

FX□□ = PLC series

- 1 Designation of the PLC series
- 2 Number of inputs/outputs e.g. 14 I/Os
- 3 Description of the unit type:
M = base unit
E = extension unit
EX = modular input extension
EY = modular output extension
- 4 Description of the output type:
R = relay
T = transistor

5a Power supply:
E = 100/240 V AC
D = 24 V DC

5b Model variants:
S = Inputs selectable as sink or source type
Relay outputs
SS = Inputs selectable as sink or source type
Transistor outputs
source type

6 UL = UL certification

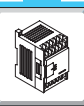

General Specifications

General Specifications	Data
Ambient temperature	0 – 55 °C
Operating temperature	0 – 55 °C
Storage temperature	-20 – +70 °C
Primary power supply	24 V DC, 200 mA; ripple ratio at maximum load: ≤ ±5 %
Protection	IP 20
Noise durability	1000 Vpp with noise generator; 1 μs at 30 – 100 Hz
Dielectric withstand voltage	1500 V AC, 1 min. (500 V AC for direct voltage modules)
Ambient relative humidity	35 – 85 % (non-condensing)
Shock resistance	10 G (3 times each in 3 directions)
Vibration resistance	2 G: resistance to vibrations from 10 – 55 Hz for 2 hours along all 3 axes; 0.5 G for DIN rail mounting
Insulation resistance	500 V DC, 5 MΩ
Ground	Class 3
Fuse	3 A
Environment	Avoid environments containing corrosive gases, install in a dust-free location.
Certifications	UL / CSA / CE / DNV / RINA

Specifications of Base Units

Specifications	FX0S-10 MR-DS	FX0S-10 MR-ES/UL	FX0S-10 MT-DSS	FX0S-14 MR-DS	FX0S-14 MR-ES/UL	FX0S-14 MT-DSS		
Electrical data								
Max. number inputs/outputs	10	10	10	14	14	14		
Power supply	AC range (+10%, -15%)	—	100–240 V AC	—	100–240 V AC	—		
	Frequency at AC	Hz	50/60 (±10%)	—	50/60 (±10%)	—		
	DC range (+10%, -15%)	24 V DC	—	24 V DC	24 V DC	—	24 V DC	
Max. input apparent power	4 W	30 VA	4 W	5 W	30 VA	5 W		
Inrush current at ON	100 V AC	—	15 A / 2 ms	—	15 A / 2 ms	—		
	200 V AC	—	25 A / 2 ms	—	25 A / 2 ms	—		
	24 V DC	60 A / 1.5 ms	—	60 A / 1.5 ms	60 A / 1.5 ms	—	60 A / 1.5 ms	
Allowable momentary power failure time	ms	5	10	5	10	5		
External current supply (24 V DC)	mA	—	200	—	200	—		
Inputs								
Integrated inputs	6	6	6	8	8	8		
Min. current for logical 1	mA	4.5	4.5	4.5	4.5	4.5		
Max. current for logical 0	mA	1.5	1.5	1.5	1.5	1.5		
Response time	ms	For all units of the MELSEC FX0S series values: 10 ms (at time of shipping), adjustable from 0 to 15 ms in steps of 1 ms.						
Outputs								
Integrated outputs	4	4	4	6	6	6		
Output	Art	Relay	Relay	Transistor	Relay	Relay	Transistor	
Switching voltage (max.)	V	Generally for relay version: < 264 V AC, < 30 V DC; for transistor version: 5 – 30 V DC						
Max. output current	- per output	A	2.5	2.5	0.5	2.5	0.5	
	- per group*	A	—	—	0.8	8	0.8	
Max. switching current	- inductive load	VA	80 VA	80 VA	12 W	80 VA	80 VA	12 W
	- lamp load	W	100	100	1.5	100	100	1.5
Response time	ms	10	10	0.2	10	10	0.2	
Life of contacts (switching times)		For all base units of the MELSEC FX0S series values: 3000000 at 20 VA; 1000000 at 35 VA; 200000 at 80 VA						
Mechanical data								
Weight	kg	0.3	0.45	0.3	0.3	0.45	0.3	
Dimensions (W x H x D)	mm	60 x 90 x 47	60 x 90 x 75	60 x 90 x 47	60 x 90 x 47	60 x 90 x 75	60 x 90 x 47	
Order information	Art. no.	55774	55773	55775	55777	55776	55778	

* The limitation applies only per reference terminal for each group, 4 and 8 outputs for relays and 2 and 4 outputs for transistors. Please observe the terminal assignments for the group identification.

Programming Specifications

System data	
Program data	
Program memory	800 steps EEPROM (internal)
Program language	Stempladder instructions, instruction list
Program execution	Periodical execution of the stored program
Program protection	Password protection with 3 protection levels
Number of instructions	20 sequence instructions, 2 step ladder instructions, 35 applied instructions
Cycle period	1.6 – 3.5 μs/log. instruction
Operands	
Internal relays	512, 16 buffered
Special relays	56
Step relays	64
Timers	56 (100 ms), with 24 to be switched to 10 ms
External setpoint entry via potentiometer	1
Counter	16 inputs, 16 Bit
High speed counter inputs	4 counter inputs, 32 Bit
Data register	32, 16 Bit
Filer register	—
Index register	2, 16 Bit
Special register	27, 16 Bit
Pointer	64
Nesting operands	8
Interrupt inputs	4
Constants	16 / 32 Bit

Specifications of Base Units

FX0S-20 MR-DS	FX0S-20 MR-ES/UL	FX0S-20 MT-DSS	FX0S-30 MR-DS	FX0S-30 MR-ES/UL	FX0S-30 MT-DSS
20	20	20	30	30	30
—	100–240 V AC	—	—	100–240 V AC	—
—	50/60 (±10%)	—	—	50/60 (±10%)	—
24 V DC	—	24 V DC	24 V DC	—	24 V DC
6 W	33 VA	6 W	8 W	35 VA	8 W
—	15 A / 2 ms	—	—	15 A / 2 ms	—
—	25 A / 2 ms	—	—	25 A / 2 ms	—
60 A / 1.5 ms	—	60 A / 1.5 ms	60 A / 1.5 ms	—	60 A / 1.5 ms
5	10	5	5	10	5
—	200	—	—	200	—
12	12	12	16	16	16
4.5	4.5	4.5	4.5	4.5	4.5
1.5	1.5	1.5	1.5	1.5	1.5
For all units of the MELSEC FX0S series values: 10 ms (at time of shipping), adjustable from 0 to 15 ms in steps of 1 ms.					
8	8	8	14	14	14
Relay	Relay	Transistor	Relay	Relay	Transistor
Generally for relay version: < 264 V AC, < 30 V DC; for transistor version: 5 – 30 V DC					
2.5	2.5	0.5	2.5	2.5	0.5
8	8	0.8	8	8	0.8
80 VA	80 VA	12 W	80 VA	80 VA	12 W
100	100	1.5	100	100	1.5
10	10	0.2	10	10	0.2
For all base units of the MELSEC FX0S series values: 3000000 at 20 VA; 1000000 at 35 VA; 200000 at 80 VA					
0.45	0.5	0.45	0.45	0.5	0.4
75 x 90 x 47	75 x 90 x 75	75 x 90 x 47	105 x 90 x 47	105 x 90 x 75	105 x 90 x 47
55787	55779	55789	55791	55790	55792

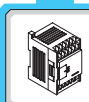

■ Simulation Strip: Input-SIM: FX0S/FX0N

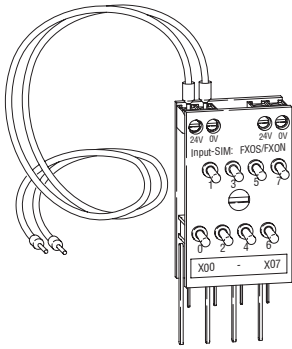

The simulation strip has 8 switches for simulating digital inputs.

The strip is directly mounted to the terminals of the unit and fixed with screws to the terminal block.

A cable is provided for connecting the strip to the power supply.

The simulation strip can be expanded with another strip for further inputs.

Specifications		Input-SIM: FX0S/FX0N
Switches		8
Dimensions (W x H x D)	mm	30 x 50 x 15
Order information	Art. no.	65081

■ Simulation Box

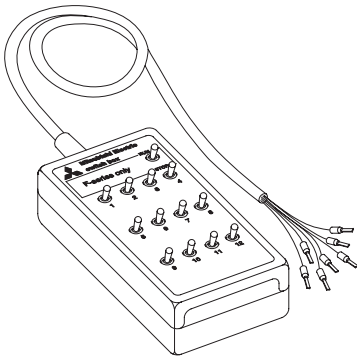

The simulation box has 12 switches for simulating digital inputs.

It can be used on all controllers of the MELSEC FX family.

Specifications		Switch Box
Switches		12
Dimensions (W x H x D)	mm	50 x 100 x 25
Order information	Art. no.	3386

■ Program Loader FX0-10LDR for FX0S in Combination with FX Memory Cassettes

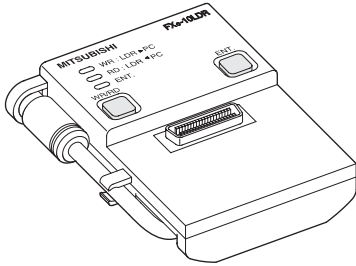

The FX0-10LDR program loader is connected directly to the PLC. It is used for transferring programs between the integrated EEPROM of FX0S units and the memory cassette which is used in the FX0-10LDR.

The FX0-10LDR can be used both with the memory cassette and the EEPROM memory of the controller.

The program is transferred to the memory set when a memory cassette is inserted.

Otherwise, the program is written into the EEPROM of the loader.

Moreover, the program can be transferred from the memory of the controller to a memory cartridge inserted in the FX0-10LDR.

Specifications	FX0-10LDR	
Environmental specifications	Conforms to FX0 base units	
Power supply	5 V DC $\pm 5\%$ (from base unit)	
Current consumption	mA	180
Weight	kg	0.08
Dimensions (W x H x D)	mm	80 x 85 x 28
Order information	Art. no.	36644



Terminal Assignment of Base Units

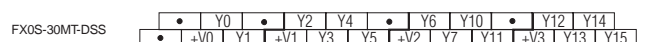
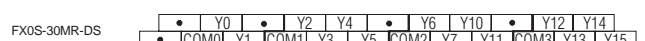
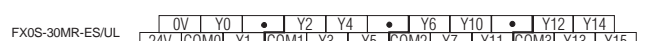
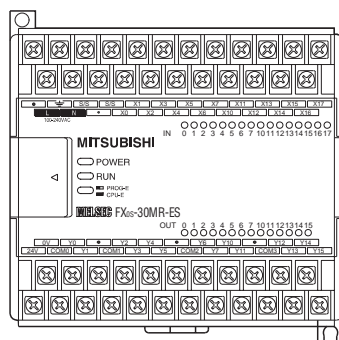
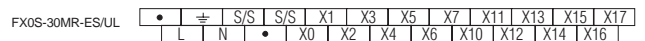
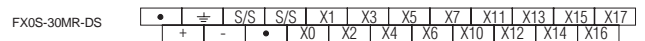
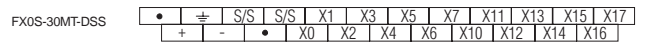
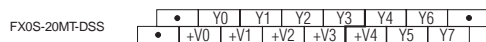
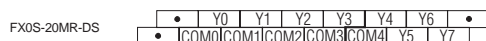
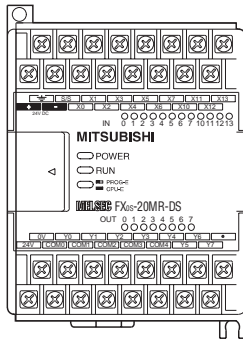
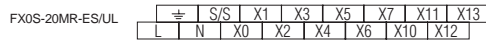
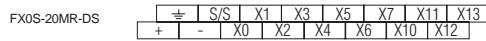
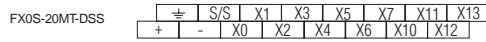
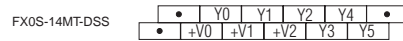
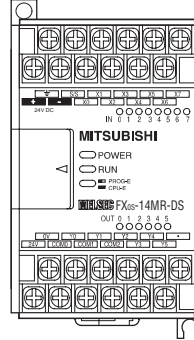
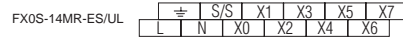
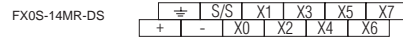
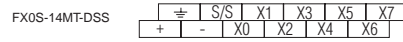
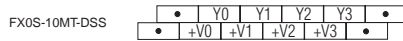
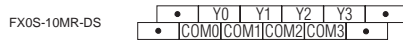
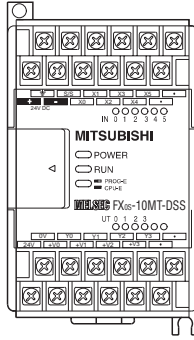
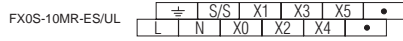
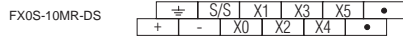
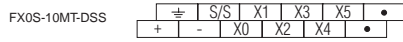

Dimensions of Base Units

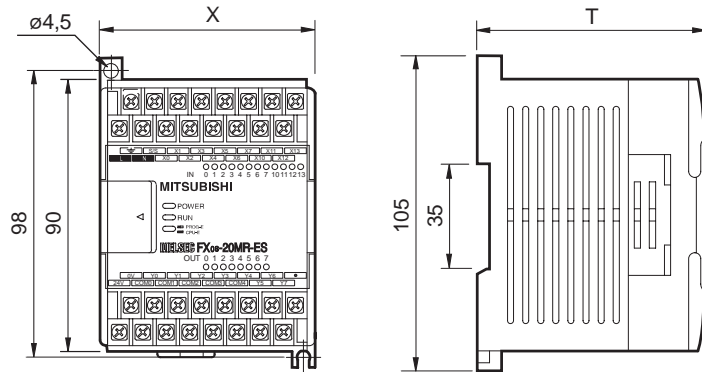

Type	X (in mm)	T (in mm)
FX0S-10MR-ES/UL	60	75
FX0S-10MR-DS	60	47
FX0S-10MT-DSS	60	47
FX0S-14MR-ES/UL	60	75
FX0S-14MR-DS	60	47
FX0S-14MT-DSS	60	47
FX0S-20MR-ES/UL	75	75
FX0S-20MR-DS	75	47
FX0S-20MT-DSS	75	47
FX0S-30MR-ES/UL	105	75
FX0S-30MR-DS	105	47
FX0S-30MT-DSS	105	47



The MELSEC FX0N Series

Description

Small-scale PLC offering excellent value for money.

- Small
- Fast
- Universal
- Modular expansion capability

The ability to combine the compact base units with small, modular expansion units and compact I/O expansion units makes the FX0N enormously flexible, giving you a highly economical combination of the cost benefits of compact systems with the versatile expansion capabilities of modular systems.

System structure

- Base unit with full PLC functionality
- Integrated power supply unit
- CPU
- Maintenance-free EEPROM memory
- Integrated digital inputs and outputs
- Expansion units for adapting the controller system to the required I/O ranges and functionality
- Configurable as a slave station in peer-to-peer and 1:n networks (version 2.00 and above)
- User-friendly programming systems, including hand-held programming units, IEC 1131.3-compatible programming software and MMIs
- Accessories

Equipment features

Base units are available in a number of versions with different power supply and output type configurations.

You can choose between units with 230 V AC or 24 V DC power supplies and relay or transistor outputs.

All the base unit versions have the same basic CPU and performance specifications.

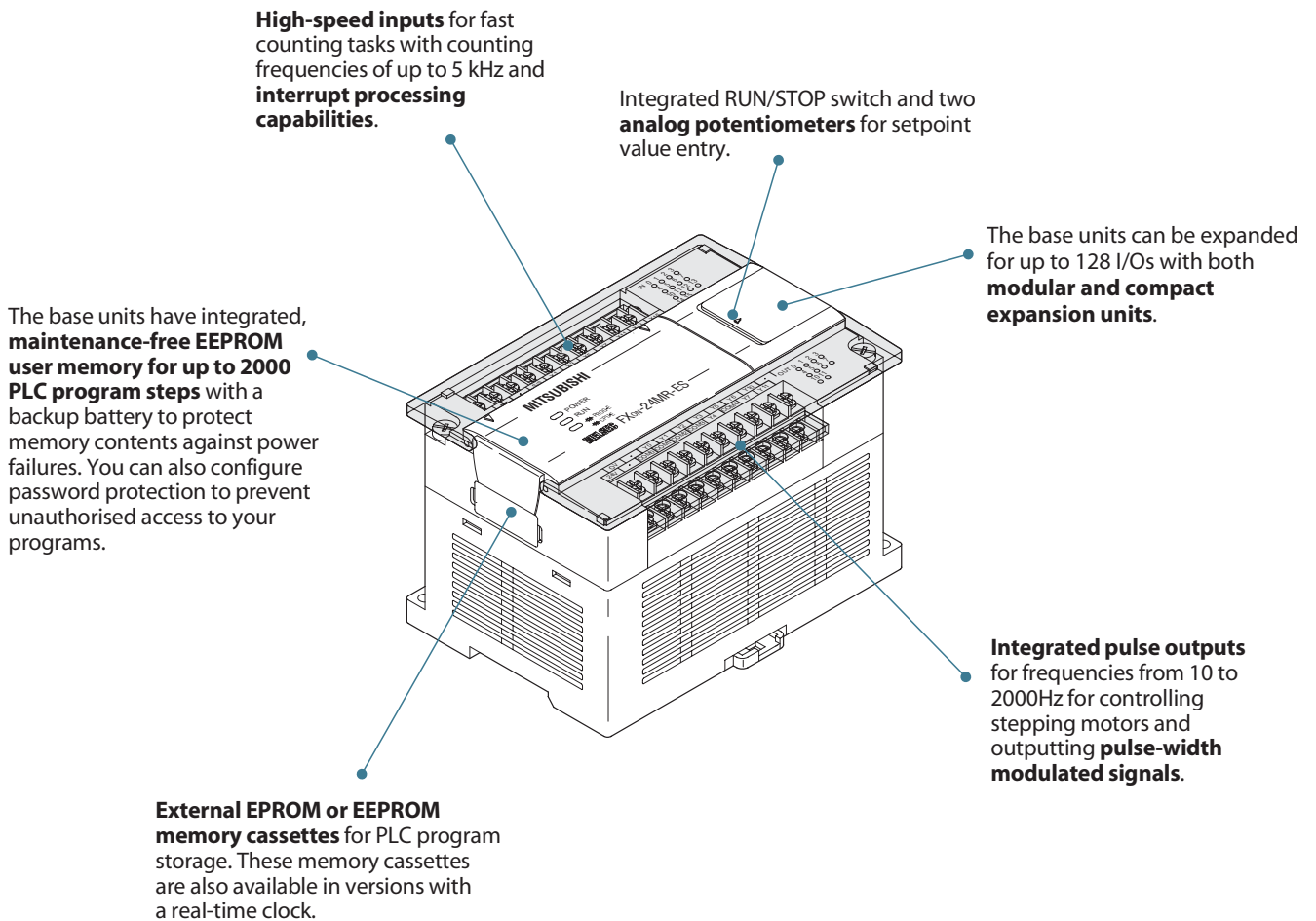

The MELSEC FX2N Series

Description

The MELSEC FX2N series has the most powerful CPUs in the MELSEC FX family. It combines the advantages of a compact PLC with the performance boost of modular PLC systems:

- One of the fastest PLC systems available, with a program cycle period of just 0.08 μ s per logical instruction
- Powerful basic instruction set with an additional 125 dedicated instructions for fast, efficient programming of complex tasks
- Simple handling
- Integrated real-time clock
- Integrated PID controller with auto-tuning facility
- Floating-point math, square root function
- Big memory capacity for up to 16000 PLC program steps

System structure

- Base unit with full PLC functionality
- Integrated power supply unit
- CPU
- Integrated digital inputs and outputs
- Supplementary add-in function boards for adapting the controller system to the required I/O ranges and functionality
- Integration as a master or slave station in peer-to-peer networks and as a slave station in 1:n networks
- Efficient, powerful user-friendly programming with hand-held programming units, MMIs and IEC 1131.3-compatible programming software
- Accessories

Equipment features

A basic MELSEC FX2N PLC system consists of a stand-alone base unit. Just like the modules in the other FX series these base units contain all the PLC components, including the CPU, memory and the I/O control circuitry.

All the base unit versions in the series have the same basic CPU and performance specifications.

A total of 20 different base units are available, with between 16 and 128 I/Os in their standard configuration. Versions are available with 230 V AC power supplies (24 V DC available from Summer 1998) and relay or transistor outputs. The digital inputs are powered by the integrated power supply unit. Removable terminal blocks make reconfiguration for new tasks very quick and easy.

A range of powerful expansion and special function modules enable you to configure your setup flexibly to provide the precise functionality and I/O specifications required by your application.

You can add I/Os to the base units by installing modular expansion units with 8 or 16 additional I/Os each. You can also add a range of compact expansion units and special function modules – for example for processing analog signals, for positioning tasks and to provide additional interfaces.

Integrated high-speed counter inputs for processing fast input signals. For example, you can configure two 60 kHz counters or four 10 kHz counters.

Interrupt processing is also handled via the inputs.

Add-in function boards can be installed in the PLC to provide a **second RS-485 / RS-422 / RS-232 communications interface** for programming or network configurations.

An add-in function board with 8 analog potentiometers is also available.

Integrated serial interface for direct communication with computers

An **integrated RUN/STOP** switch is available

RAM/EEPROM memory for up to **16000 PLC program steps** gives you plenty of reserve, even for big, complex applications.

The base units can be expanded to provide configurations with up to 256 inputs and outputs with **modular and compact expansion units**.

Integrated real-time clock with year, month and time

Integrated pulse outputs for frequencies from 10 to 20000 Hz with **deceleration and acceleration ramps** for controlling stepping motors and outputting **pulse-width modulated signals**.

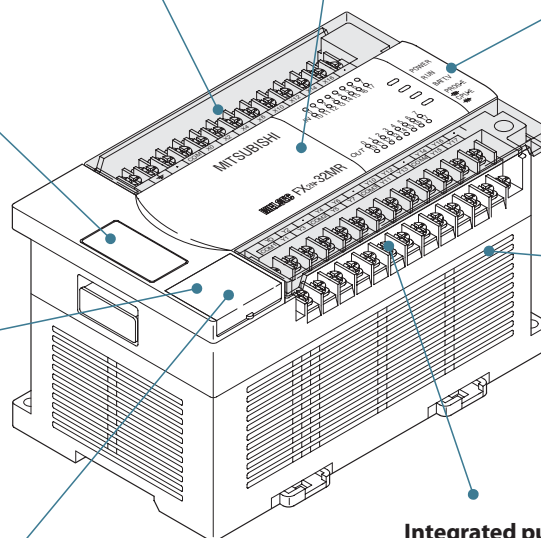

Description of Units

■ FX0N series

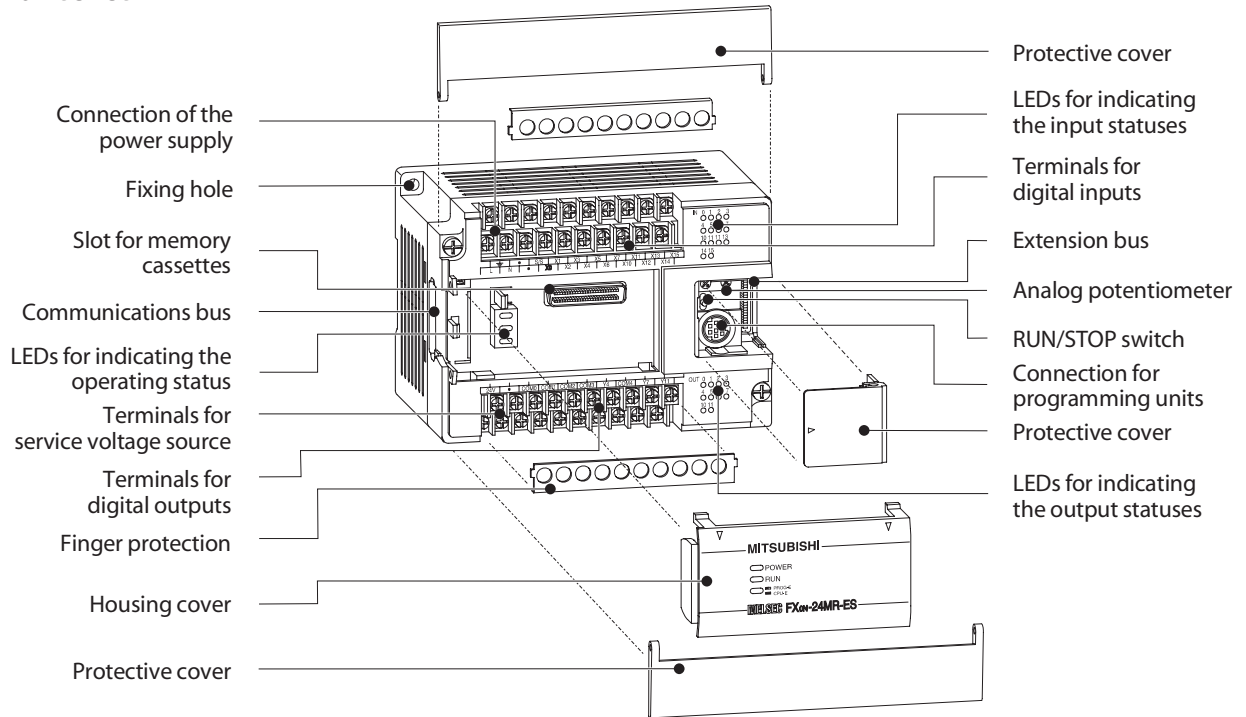

■ FX2N series

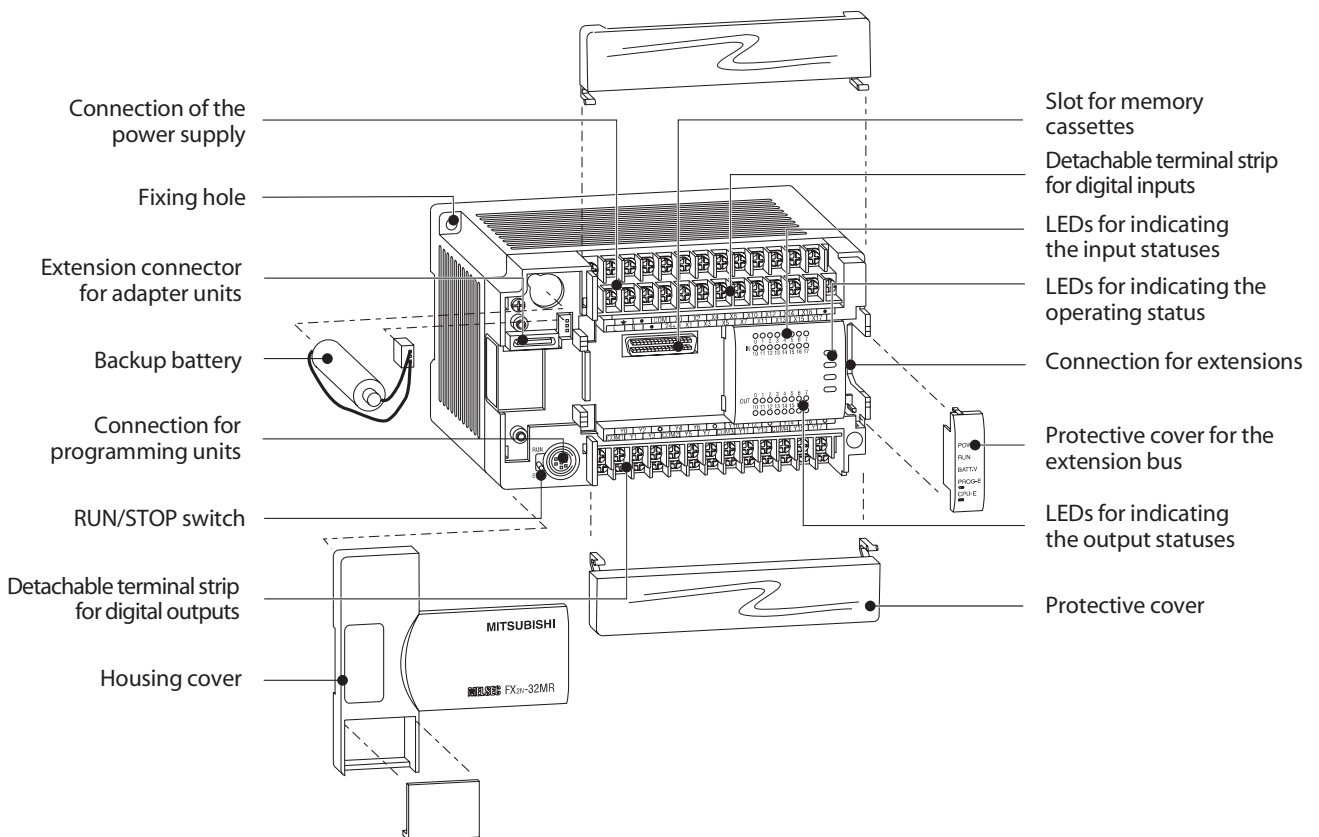

Combining Units from Different Series

The I/O expansion modules and special function modules from the two series can be combined at will, subject to the restrictions imposed by the differences between the systems.

For example, you can use all the modules for the FX0N series in combination with a base unit from the FX2N series. Combined use of modules from both series is also possible.

A special conversion adapter is available (designation: FX2N-CNV-IF) for connecting modules from the old FX series to the base units of the FX2N series.

The tables and figures below show the restrictions and other special requirements that apply for combined use of modules from different systems.

Series	FX0N	FX2N
Restrictions	All special functions modules are applicable with CPU version 2.00 or higher	—
Special requirements	—	Modules FX0N-485ADP and FX0N-232ADP connect to the left of the CPU and require function board FX2N-CNV-BD for connection to the FX2N.

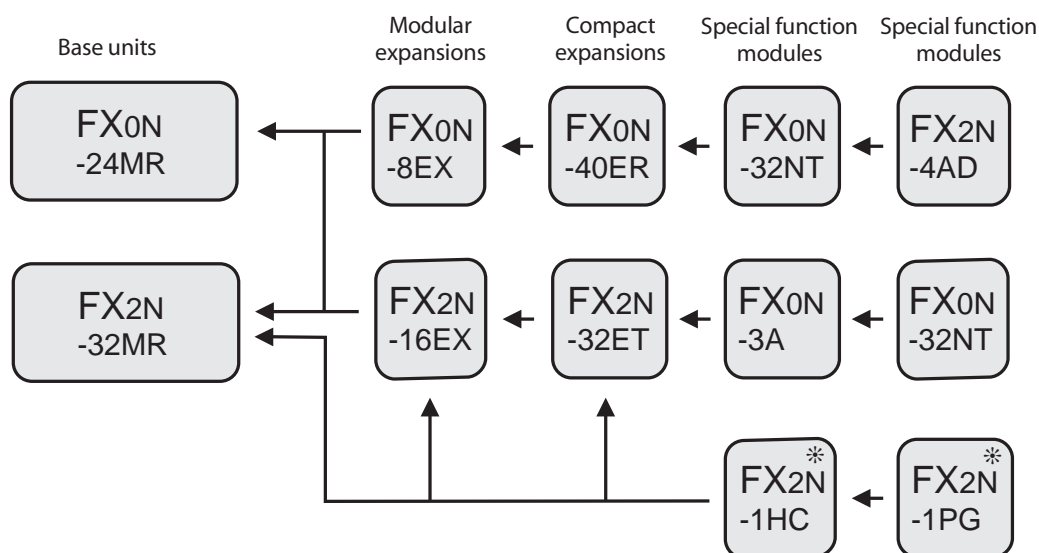

* Can also be used with MELSEC FX0N and CPU version 2.00 or higher

CPU version 2.0

All base units of the FX0N series are now shipped with the 2.0 version of the CPU. If you already have an FX0N base unit you can check the CPU version by comparing the serial number to the entries in the table on the right.

Version 1.30	Version 2.00	Remark
Up to no.78□□□□	From no.78□□□□	For all FX0N base units except FX0N-60MR-DS
Up to no.79□□□□	From no.7XIII	For FX0N-60MR-DS only

Special Function Modules MELSEC FX0N/FX2N

☑ FX0N ☑ FX2N

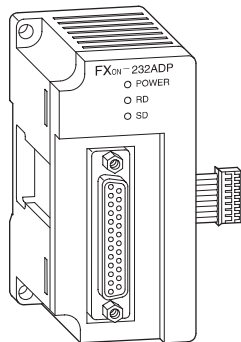

Left-side installation

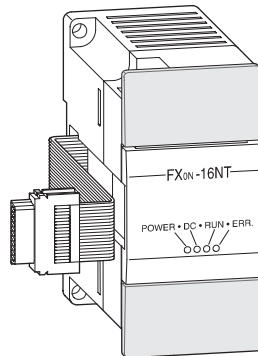

Right-side installation

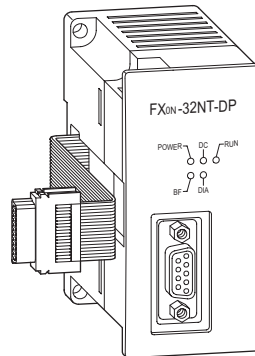

Right-side installation

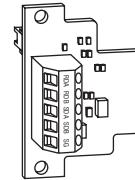

Installation in base unit

In general

Additional special function modules are available that make it possible to extend the capacity of the basic and extension units of your PLC system.

There are three basic categories of special function modules:

- Modules that occupy digital I/Os (connected on the right hand side of the controller unit). These are the digital compact and modular extension units as well as the special function modules.
- Modules of the FX0N series that do not occupy any digital I/Os (connected on the left hand side of the controller unit). These are the FX0N-232ADP and the FX0N-485ADP.
- Internal adapter boards for the FX2N series. These expansion units are installed directly in the controller and do not occupy any digital I/Os.

FX0N series configuration notes

The configuration specifications for the FX0N series permit connection of the following combinations of expansion units to the base units:

- a maximum of 2 special function modules or
- digital expansion modules with up to 32 inputs and outputs (4 x 8 I/Os or 2 x 16 I/Os) or
- one special function module and one digital expansion module with up to 16 inputs and outputs (2 x 8 I/Os or 1 x 16 I/Os)

The same configuration specifications apply for the connection of compact expansion modules.

Provided you observe these rules the system's power supply will also be adequate to provide the 24 V DC input required by the FX0N-232ADP communications module.

Similarly, the power supply for MMIs such as the FX-DU control panels and MAC operator terminals is provided via the system's 5 V bus.

FX2N series configuration notes

The configuration specifications for the FX2N series permit connection of the following combinations of units:

- A maximum of 8 special function modules or
- Digital expansion modules with up to 256 I/Os

Please note that it is important to calculate the connected load to ensure that the internal 5 V bus has adequate capacity for the installed modules.

When using special function modules you must also check the 24 V power supply load – the necessary 24 V power can be drawn from the internal service power supply, but it may be necessary to complement this with an external power supply in some configurations.

You can calculate the precise power load with the values provided in the table on the next page.

Calculation of the Power Consumption

FX0N FX2N

The power consumption figures on the 5 V DC bus for the special function modules are shown in the specifications tables on the following pages.

The maximum permissible currents on the 5 V DC bus are shown in the table below.

Module	Max. current on 5 V bus
FX2N-□□M□-ES(ESS)	290 mA
FX2N-□□E□-ES(ESS)	690 mA

The residual currents for the 24 V DC service voltage at different input/output configurations are shown in the tables on the right.

Special function modules have to be supplied external, if the residual current for the service voltage is not satisfying.

A maximum of 256 I/Os are possible.

Max. residual current values (in mA) for FX2N-16M□-E□□ through FX2N-32M□-E□□, FX2N-32E□-E□□ for the permissible configuration

Number of additional outputs	24	25				
	16	100	50	0		
	8	175	125	75	25	
	0	250	200	150	100	50
		0	8	16	24	32
Number of additional inputs						

Max. residual current values (in mA) for FX2N-48M□-E□□ through FX2N-128M□-E□□, FX2N-48E□-E□□ for the permissible configuration

Number of additional outputs	48	10								
	40	85	35							
	32	160	110	60	10					
	24	235	185	135	85	35				
	16	310	260	210	160	110	60	10		
	8	385	335	285	235	185	135	85	35	
	0	460	410	360	310	260	210	160	110	60
		0	8	16	24	32	40	48	56	64
Number of additional inputs										

Sample calculations

FX0N FX2N

The table below and on the right show different examples for sample power calculation for a PLC system.

The current values for the special function modules can be found in the specifications on the following pages.

Comparison with the current value tables show that the calculated figures for the 5 V bus lie within the allowable ranges.

In the example below all units can be supplied sufficiently with the internal 24 V power supply.

Module	No.	24 V DC calculation		5 V DC calculation	
		Current / module	Calculation	Current / module	Total current
FX2N-80MR-ES	1	460 mA	+460 mA	+290 mA	+290 mA
FX2N-4AD	3	50 mA	-150 mA	30 mA	-90 mA
FX2N-4DA	2	200 mA	-400 mA	30 mA	-60 mA
FX2N-232IF	1	80 mA	-80 mA	40 mA	-40 mA
		-170 mA !!!			
				Result:	100 mA (OK !)

An external 24 V power supply has to be added in the example above.



Module	No.	Number of I/Os			24 V DC calculation		5 V DC calculation		
		X	Y	X/Y	Total ^①	Total current ^②	Current / module	Total current	
FX2N-48MR-ES/UL	1	24	24	—	X = 8 Y = 24 →	+185 mA	290 mA	+290 mA	
FX2N-16EYR-ES/UL	1	—	16	—			—	0 mA	
FX2N-8EX-ES/UL	1	8	—	—			—	0 mA	
FX2N-8EYR-ES/UL	1	—	8	—			—	0 mA	
FX0N-3A	1	—	—	8			-90 mA	30 mA	-30 mA
		64 + 64 + 24 = 152 ! (< 256) OK!			+95 mA (OK!)		+260 mA (OK!)		
FX2N-32ER-ES/UL	1	16	16	—	X = 16 Y = 0 →	+150 mA	690 mA	+690 mA	
FX2N-16EX-ES/UL	1	16	—	—			—	0 mA	
FX2N-4AD	1	—	—	8			30 mA	50 mA	-30 mA
FX2N-1HC	1	—	—	8			0 mA	40 mA	-90 mA
Result:		64 + 64 + 24 = 152 ! (< 256) OK!			+120 mA (OK!)		+570 mA (OK!)		

^① Total no. of I/Os which are connected to a base unit to calculate the max. residual current values (see tables) ^② see tables above (max. residual current values)

Configuration Example FX0N

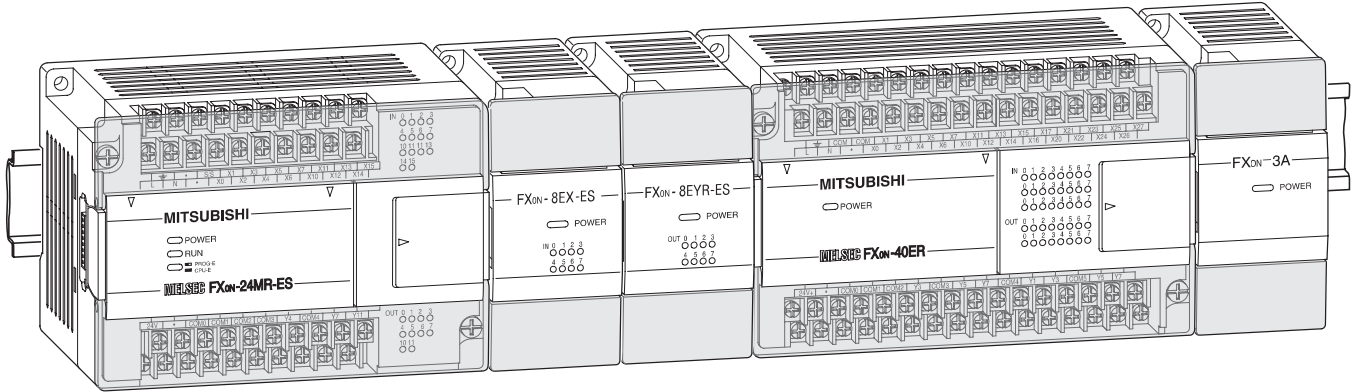

The addressing of the special function modules is independent of the addressing of the digital inputs/outputs. An example of addressing is shown in the table on the right.

Configuration	FX0N-24MR-ES	FX0N-8EX	FX0N-8EYR	FX0N-40ER-ES	FX0N-3A	Total
Number						
Inputs X	14	8	—	24	—	46
Outputs Y	10	—	8	16	—	34
Special function modules	—	—	—	—	8	8
Addresses						
Inputs X	0-15	20-27	—	30-57	—	
Outputs Y	0-11	—	20-27	30-47	—	
Special function modules					No.0	
						Σ 88

Configuration Example FX2N

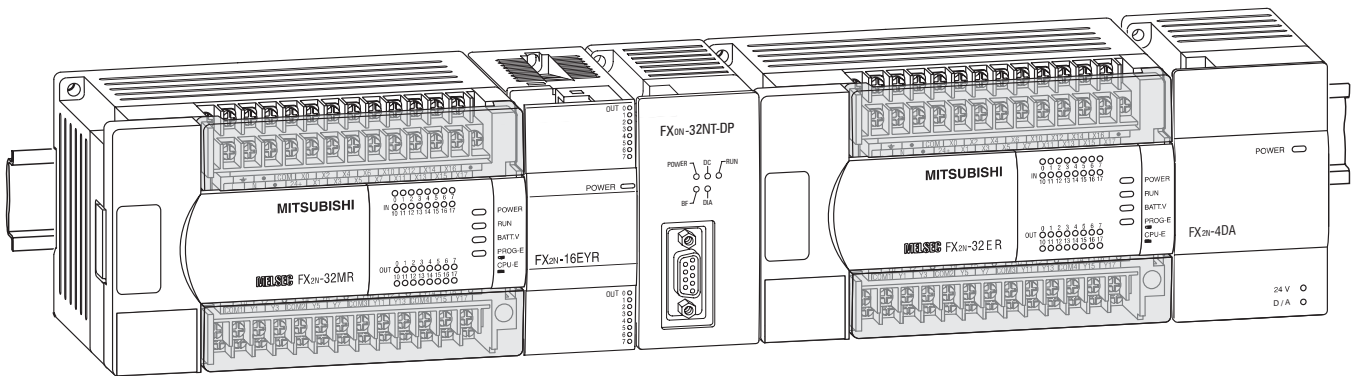

The addressing of the special function modules is independent of the addressing of the digital inputs/outputs. An example of addressing is shown in the table on the right.

Configuration	FX2N-32MR-ES	FX2N-16EYR	FX0N-32NT/DP	FX2N-32ER-ES	FX0N-4DA	Total
Number						
Inputs X	16	—	—	16	—	32
Outputs Y	16	16	—	16	—	48
Special function modules	—	—	8	—	8	16
Addresses						
Inputs X	0-17	—	—	20-37	—	
Outputs Y	0-17	20-37	—	40-57	—	
Special function modules			No.0		No.1	
						Σ 96

Environmental Specifications

 FX0N FX2N

General specifications	Data
Ambient temperature	0 – 55 °C
Operating temperature	0 – 55 °C
Storage temperature	-20 – +70 °C
Service power supply	24 V DC, 200 mA (FX0N); 250/460 mA (FX2N) ripple ratio at maximum load: ≤ ±5 %
Protection	IP 20
Noise durability	1000 Vpp with noise generator; 1 ms at 30 – 100 Hz
Dielectric withstand voltage	1500 V AC, 1 min.
Ambient relative humidity	35 – 85 % (non-condensing)
Shock resistance	10 G (3 times in 3 directions)
Vibration resistance	2 G: resistance to vibrations from 10 – 55 Hz for 2 hours along all 3 axes; 0.5 G for DIN rail mounting
Insulation resistance	500 V DC, 5 MΩ
Ground	Class 3
Fuse	FX0N: 3 A (all units), FX2N: 3, 15 A (up to FX2N-32□□); 5 A (from FX2N-48□□)
Environment	Avoid environments containing corrosive gases, install in a dust-free location.
Certifications	FX0N: UL/CSA/CE/DNV/RINA, FX2N: UL/CSA/CE/DNV/LL

General Specifications

 FX0N FX2N

System specifications	FX0N	FX2N
Program data		
I/O points (addresses)	128	256
Address range	Max. 84 inputs X0–X123, max. 64 outputs Y0–Y77	Max. 256 inputs X0–X377, max. 256 outputs Y0–Y377
Program memory	2000 steps EEPROM (internal), EEPROM/ EPROM cassettes (optional)	8000 steps RAM (internal), 4000 steps EPROM/EEPROM cassettes (optional), 16000 steps RAM cassettes (optional), 16000 steps EEPROM cassettes (optional) <small>for further details refer to p.52</small>
Cycle period	Min. 1.6 μs / logical instruction	0.08 μs / logical instruction
Number of instructions	20 sequence instructions, 2 stepladder instructions, 42 applied instructions	27 sequence instructions, 2 stepladder instructions, 18 verify instructions, 107 applied instructions
Programming language	Stepladder, instruction list	Stepladder, instruction list, SFC
Program execution	Cyclical execution, refresh mode processing	Cyclical execution, refresh mode processing
Program protection	Password protection with 3 protection levels	Password protection with 3 protection levels
Operands		
Internal relays	512 (128 buffered)	3072
Special relays	57	256
Step ladder	128	1000
Timer	64	256
Ext. preset value via potentiometer	2	—
Counter	32 (16 buffered)	256
High-speed counter	Max. 4	6 single phase inputs (4 double phase inputs)
Real-time clock	—	Year, month, day, hour, minut, second, weekday
Data register	256 (128 buffered)	8000
File register	Max. 1500	Max. 7000 (parameter editable)
Index register	2	16
Special register	28	256
Pointer	64	128
Nestings	8	8
Interrupt inputs	Max. 4	6
Constants	16 bits: K: -32768 to +32767, hex: 0–FFFF 32 bits: K: 2147483648 to +2147483647, hex: 0–FFFF FFFF	16 bits: K: -32768 to +32767, hex: 0–FFFF 32 bits: K: 2147483648 to +2147483647, hex: 0–FFFF FFFF 32 bits floating point: 0, ±1.175 x 10 ⁻³⁸ to ±3.403 x 10 ⁻³⁸

Specifications of Base Units

FX0N FX2N

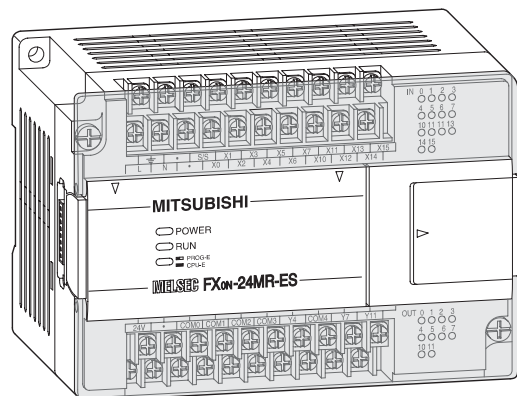

Base Units FX0N

The FX0N series base units are available with 24, 40 or 60 input/output points. It is possible to choose between relay and transistor output type.

Special features:

- Integrated serial interface for communication between PC and HMI
- Standard programming unit interface
- LEDs for indicating the input and output status
- Detachable terminal blocks at units with 40 and 60 I/Os
- Slot for memory cassettes and real-time clock

Specifications	FX0N-24 MR-DS	FX0N-24 MR-ES/UL	FX0N-24 MT-DSS	FX0N-40 MR-DS	FX0N-40 MR-ES/UL	FX0N-40 MT-DSS	
Electrical data							
Integrated inputs/outputs	24	24	24	40	40	40	
Power supply	AC range (+10%, -15%)	—	100–240 V AC	—	100–240 V AC	—	
	Frequency at AC	Hz	50/60 (±10%)	—	50/60 (±10%)	—	
	DC range (+20%, -15%)	24 V DC	—	24 V DC	24 V DC	—	24 V DC
Max. input apparent power	18 W	50 VA	18 W	20 W	50 VA	20 W	
Inrush current at ON	100 V AC	—	30 A / 5 ms	—	30 A / 5 ms	—	
	200 V AC	—	50 A / 5 ms	—	50 A / 5 ms	—	
	24 V DC	60 A / 50 μs	—	60 A / 50 μs	60 A / 50 μs	—	60 A / 50 μs
Allowable momentary power failure time	10	10	10	10	10	10	
External service power supply (24 V DC)	—	200	—	—	200	—	
Inputs							
Integrated inputs	14	14	14	24	24	24	
Min. current for logical 1	mA	3.5	3.5	3.5	3.5	3.5	
Max. current for logical 0	mA	1.5	1.5	1.5	1.5	1.5	
Response time	For all base units of the MELSEC FX0N series values: 10 ms (at time of shipment), partly adjustable between 0 and 15 ms						
Outputs							
Integrated outputs	10	10	10	16	16	16	
Output type	Relay	Relay	Transistor	Relay	Relay	Transistor	
Max. switching voltage	V	Generally for relay version: < 264 V AC, < 30 V DC; for transistor version: 5 – 30 V DC					
Max. output current	- per output	A	2	0,5	2	0,5	
	- per group*	A	—	0,8	—	0,8	
Max. switching power	- inductive load	VA	80	12	80	12	
	- lamp load	W	100	1,5	100	1,5	
Response time	ms	10	< 0,2	10	10	< 0,2	
Life of contacts (switching times)	For all base units of the MELSEC FX0N series values: 3000000 at 20 VA; 1000000 at 35 VA; 200000 at 80 VA						
Mechanical data							
Weight	kg	0.6	0.6	0.6	0.75	0.75	
Dimensions (W x H x D)	mm	130 x 90 x 87	130 x 90 x 87	130 x 90 x 87	150 x 90 x 87	150 x 90 x 87	
Order information	Art. no.	66657	66656	66658	66660	66659	66661

* This limitation applies only per reference terminal for each group, 4 and 8 outputs for relays and 2 and 4 outputs for transistors. Please observe the terminal assignments for the group identification.

Specifications of Base Units

FX0N FX2N

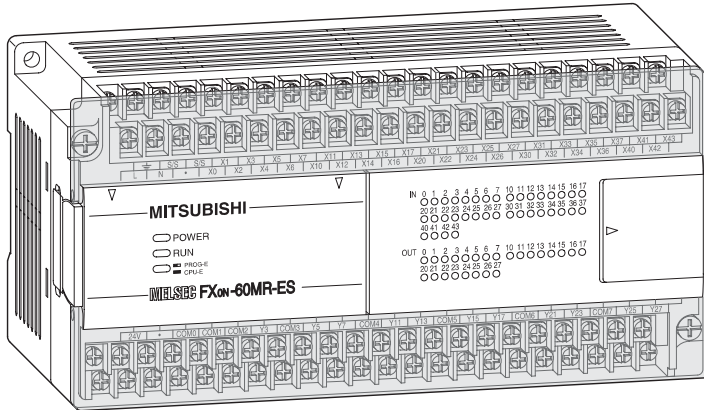

Specifications	FX0N-60 MR-DS	FX0N-60 MR-ES/UL	FX0N-60 MT-DSS
Electrical data			
Integrated inputs/outputs	60	60	60
Power supply	AC range (+10%, -15%)	—	100–240 V AC
	Frequency at AC	Hz	50/60 (±10 %)
	DC range (+20%, -15%)	24 V DC	—
Max. input apparent power	24 W	60 VA	24 W
Inrush current at ON	100 V AC	—	30 A / 5 ms
	200 V AC	—	50 A / 5 ms
	24 V DC	60 A / 50 μs	—
Allowable momentary power failure time	10	10	10
External service power supply (24 V DC)	mA	200	—
Inputs			
Integrated inputs	36	36	36
Min. current for logical 1	mA	3.5	3.5
Max. current for logical 0	mA	1.5	1.5
Response time	For all base units of the MELSEC FX0N series values: 10 ms (at time of shipment), partly adjustable between 0 and 15 ms		
Outputs			
Integrated outputs	24	24	24
Output type	Relay	Relay	Transistor
Max. switching voltage	V	Generally for relay version: < 264 V AC, < 30 V DC; for transistor version: 5 – 30 V DC	
Max. output current	- per output	A	2
	- per group*	A	—
Max. switching power	- inductive load	VA	80
	- lamp load	W	100
Response time	ms	10	< 0.2
Life of contacts (switching times)	For all base units of the MELSEC FX0N series values: 3000000 at 20 VA; 1000000 at 35 VA; 200000 at 80 VA		
Mechanical data			
Weight	kg	0.9	0.9
Dimensions (W x H x D)	mm	185 x 90 x 87	185 x 90 x 87
Order information	Art. no.	66663	66664

* This limitation applies only per reference terminal for each group, 4 and 8 outputs for relays and 2 and 4 outputs for transistors. Please observe the terminal assignments for the group identification.



Specifications for Base Units

FX0N FX2N

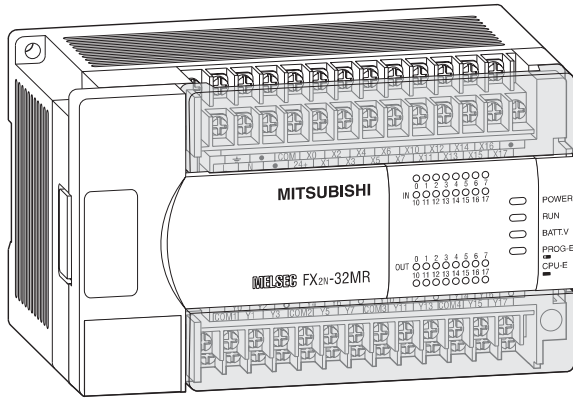

Base Units FX2N

The FX2N series base units are available with 16, 32, 48, 64, 80 or 128 input/output points. It is possible to choose between relay and transistor output type.

Special features:

- Exchangable interface modules for direct mounting into a base unit
- Standard programming unit interface
- LEDs for indicating the input and output status
- Detachable terminal blocks
- Slot for memory cassettes for up to 16 k steps PLC program
- Integrated real-time clock

Specifications	FX2N-16 MR-ES/UL	FX2N-16 MT-ESS/UL	FX2N-32 MR-DS ^②	FX2N-32 MR-ES/UL	FX2N-32 MT-DSS ^②	FX2N-32 MT-ESS/UL
Electrical data						
Integrated inputs/outputs	16	16	32	32	32	32
Power supply	AC range (+10%,-15%)	100–240 V AC	—	100–240 V AC	—	100–240 V AC
	Frequency at AC	50/60 (±10 %)	—	50/60 (±10 %)	—	50/60 (±10 %)
	DC range (+20 %, -30 %)	—	—	24 V DC	—	24 V DC
Max. input apparent power	30 VA	30 VA	25 W	40 VA	25 W	40 VA
Inrush current at ON	AC 100 V	40 A < 5 ms	—	40 A < 5 ms	—	40 A < 5 ms
	AC 200 V	60 A < 5 ms	—	60 A < 5 ms	—	60 A < 5 ms
Allowable momentary power failure time	ms	10	5	10	5	10
External service power supply (24 V DC)	mA	250	—	250	—	250
Power supply int. bus (5 V DC)	mA	290	290	290	290	290
Inputs						
Integrated inputs	8	8	16	16	16	16
Input current X0→X7 / X10→∞	mA	7 / 5	7 / 5	7 / 5	7 / 5	7 / 5
Min. current for logical 1 X0→X7 / X10→∞	mA	4.5 / 3.5	4.5 / 3.5	4.5 / 3.5	4.5 / 3.5	4.5 / 3.5
Max. current for logical 0	mA	1.5	1.5	1.5	1.5	1.5
Isolation	Photocoupler isolation between input terminals and PC power for all base units.					
Response time	For all base units of the MELSEC FX2N series values: 10 ms (at time of shipment), partly adjustable between 0 and 15 ms (REF, FNC51 = 0 – 60 ms)					
Outputs						
Integrated outputs	8	8	16	16	16	16
Output type	Relay	Transistor	Relay	Relay	Transistor	Transistor
ON voltage (max.)	Generally for relay version: < 250 V AC, < 30 V DC; for transistor version: 5 – 30 V DC					
Max. output current	- per output	A	2	0.5	2	0.5
	- per group ^①	A	—	0.8	—	0.8
Max. switching power	- inductive load	W	80	12	80	12
	- lamp load	W	100	1.5	100	1.5
Response time	ms	10	< 0.2	10	< 0.2	< 0.2
Life of contacts (switching times)	For all base units of the FX2N series values: 3000000 at 20 VA; 1000000 at 35 VA; 200000 at 80 VA					
Mechanical data						
Weight	kg	0.6	0.6	0.65	0.65	0.65
Dimensions (W x H x D)	mm	130 x 90 x 87	130 x 90 x 87	150 x 90 x 87	150 x 90 x 87	150 x 90 x 87
Order information						
Art. no.	65550	65551	66620	65553	66621	65554

^① This limitation applies only per reference terminal for each group, 4 and 8 outputs for relays and 2 and 4 outputs for transistors. Please observe the terminal assignments for the group identification.

^② Available until 07/1998

Specifications of Base Units

FX0N FX2N

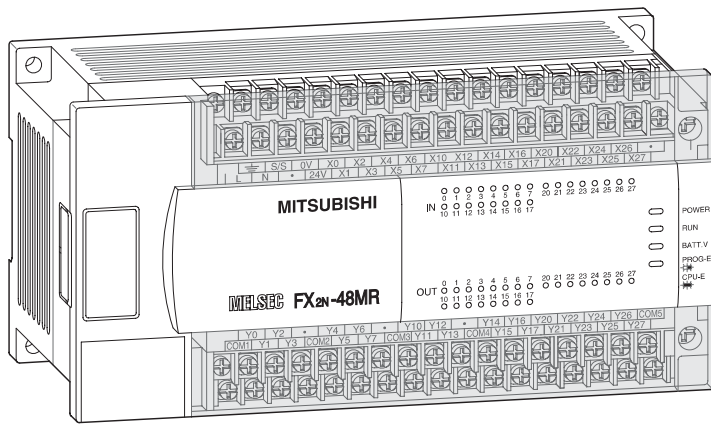

FX2N-48 MR-DS ^②	FX2N-48 MR-ES/UL	FX2N-48 MT-ESS/UL	FX2N-48 MT-DSS ^b	FX2N-64 MR-DS ^b	FX2N-64 MR-ES/UL	FX2N-64 MT-DSS ^b	FX2N-64 MT-ESS/UL
48	48	48	48	64	64	64	64
—	100–240 V AC	100–240 V AC	—	—	100–240 V AC	—	100–240 V AC
—	50/60 (±10 %)	50/60 (±10 %)	—	—	50/60 (±10 %)	—	50/60 (±10 %)
24 V DC	—	—	24 V DC	24 V DC	—	24 V DC	—
30 W	50 VA	50 VA	30 W	35 W	60 VA	35 W	60 VA
—	40 A < 5 ms	40 A < 5 ms	—	—	40 A < 5 ms	—	40 A < 5 ms
—	60 A < 5 ms	60 A < 5 ms	—	—	60 A < 5 ms	—	60 A < 5 ms
5	10	10	5	5	10	5	10
—	460	460	—	—	460	—	460
290	290	290	290	290	290	290	290
24	24	24	24	32	32	32	32
7/5	7/5	7/5	7/5	7/5	7/5	7/5	7/5
4.5/3.5	4.5/3.5	4.5/3.5	4.5/3.5	4.5/3.5	4.5/3.5	4.5/3.5	4.5/3.5
1.5	1.5	1.5	1.5	1.5	1.5	1.5	1.5
Photocoupler isolation between input terminals and PC power for all base units.							
For all base units of the MELSEC FX2N series values: 10 ms (at time of shipment), partly adjustable between 0 and 15 ms (REF, FNC51 = 0 – 60 ms)							
24	24	24	24	32	32	32	32
Relay	Relay	Transistor	Transistor	Relay	Relay	Transistor	Transistor
Generally for relay version: < 250 V AV, < 30 V DC; for transistor version: 5 – 30 V DC							
2	2	0.5	0.5	2	2	0.5	0.5
8	8	0.8	0.8	8	8	0.8	0.8
80	80	12	12	80	80	12	12
100	100	1.5	1.5	100	1.5	1.5	1.5
10	10	< 0.2	< 0.2	10	10	< 0.2	< 0.2
For all base units of the FX2N series values: 3000000 at 20 VA; 1000000 at 35 VA; 200000 at 80 VA							
0.85	0.85	0.85	0.85	1.0	1.0	1.0	1.0
182 x 90 x 87	182 x 90 x 87	182 x 90 x 87	182 x 90 x 87	220 x 90 x 87	220 x 90 x 87	220 x 90 x 87	220 x 90 x 87
66622	65560	65561	66623	66624	65562	66626	65563

① This limitation applies only per reference terminal for each group, 4 and 8 outputs for relays and 2 and 4 outputs for transistors. Please observe the terminal assignments for the group identification.

② Available until 07/1998

Specifications of Base Units

FX0N FX2N

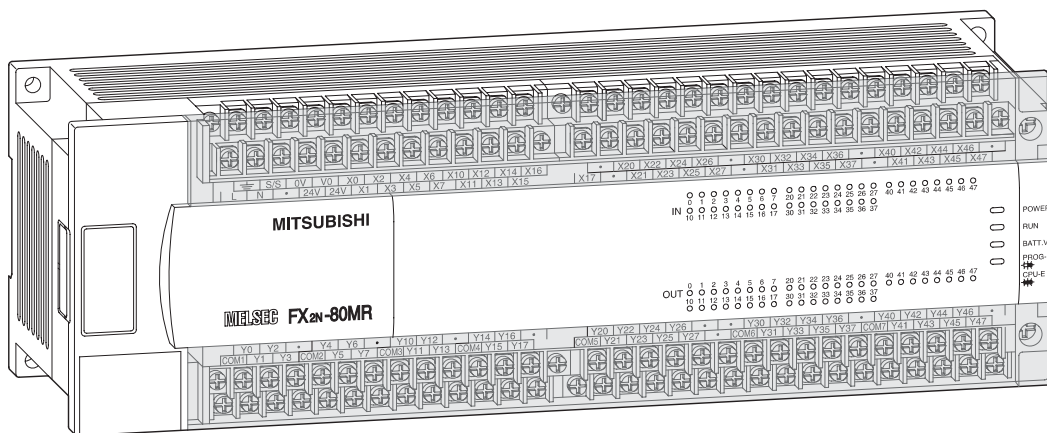

Specifications	FX2N-80 MR-DS ^②	FX2N-80 MR-ES/UL	FX2N-80 MT-ESS/UL	FX2N-80 MT-DSS ^b	FX2N-128 MR-ES/UL	FX2N-128 MT-ESS/UL
Electrical data						
Integrated inputs/outputs	80	80	80	80	128	128
Power supply	AC range (+10%,-15%)	—	100–240 V AC	100–240 V AC	—	100–240 V AC
	Frequency at AC	Hz	50/60 (±10 %)	50/60 (±10 %)	—	50/60 (±10 %)
	DC range (± 8 V)	24 V DC	—	—	24 V DC	—
Max. input apparent power	40 W	70 VA	70 VA	40 W	100 VA	100 VA
Inrush current at ON	100 V AC	—	40 A < 5 ms	—	50 A < 7 ms	50 A < 7 ms
	200 V AC	—	60 A < 5 ms	—	70 A < 7 ms	70 A < 7 ms
Allowable momentary power failure time	ms	5	10	5	10	10
External service power supply (24 V DC)	mA	—	460	460	—	460
Power supply int. bus (5 V DC)	mA	290	290	290	290	290
Inputs						
Integrated inputs	40	40	40	40	64	64
Input current X0→X7 / X10→∞	mA	7 / 5	7 / 5	7 / 5	7 / 5	7 / 5
Min. current for logical 1 X0→X7 / X10→∞	mA	4.5 / 3.5	4.5 / 3.5	4.5 / 3.5	4.5 / 3.5	4.5 / 3.5
Max. current for logical 0	mA	1.5	1.5	1.5	1.5	1.5
Isolation	Photocoupler isolation between input terminals and PC power for all base units					
Response time	For all base units of the MELSEC FX2N series values: 10 ms (at time of shipment), partly adjustable between 0 and 15 ms (REF, FNCS1 = 0 – 60 ms)					
Outputs						
Integrated outputs	40	40	40	40	64	64
Output type	Relay	Relay	Transistor	Transistor	Relay	Transistor
ON voltage (max.)	Generally for relay version: < 250 V AC, < 30 V DC; for transistor version: 5 – 30 V DC					
Max. output current	- per output	A	2	0.5	0.5	0.5
	- per group*	A	8	0.8	0.8	0.8
Max. switching power	- inductive load	W	80	12	12	12
	- lamp load	W	100	1.5	1.5	1.5
Response time	ms	10	< 0.2	< 0.2	10	< 0.2
Life of contacts (switching times)	For all base units of the FX2N series values: 3000000 at 20 VA; 1000000 at 35 VA; 200000 at 80 VA					
Mechanical data						
Weight	kg	1.2	1.2	1.2	1.8	1.8
Dimensions (W x H x D)	mm	285 x 90 x 87	285 x 90 x 87	285 x 90 x 87	350 x 90 x 87	350 x 90 x 87
Order information						
Art. no.	66627	65564	65565	66628	65566	65567

① This limitation applies only per reference terminal for each group, 4 and 8 outputs for relays and 2 and 4 outputs for transistors. Please observe the terminal assignments for the group identification.

② Available until 07/1998

Digital Inputs/Outputs

Various modular and compact extension units are available for extending the MELSEC MELSEC FX0N/FX2N base units. The modular extension units contain only digital inputs/outputs and no separate power supply, while compact extension units contain a larger number of inputs/outputs and an integrated power supply unit for supplying the system bus and the digital inputs.

The large number of possible combinations of base and extension units of the MELSEC FX0N/FX2N ensure that the best possible economical solution is found for every application.

Owing to the capacity of the internal power supply unit of the respective base unit or of the compact extension unit, modular expandability of the controller is possible with the help of a protected flat cable.

A base unit can be extended by a maximum of 128 (FX0N series) or 256 (FX2N series) external inputs/outputs by means of these extension units.

FX0N and FX2N series extension units can be combined without any problems.

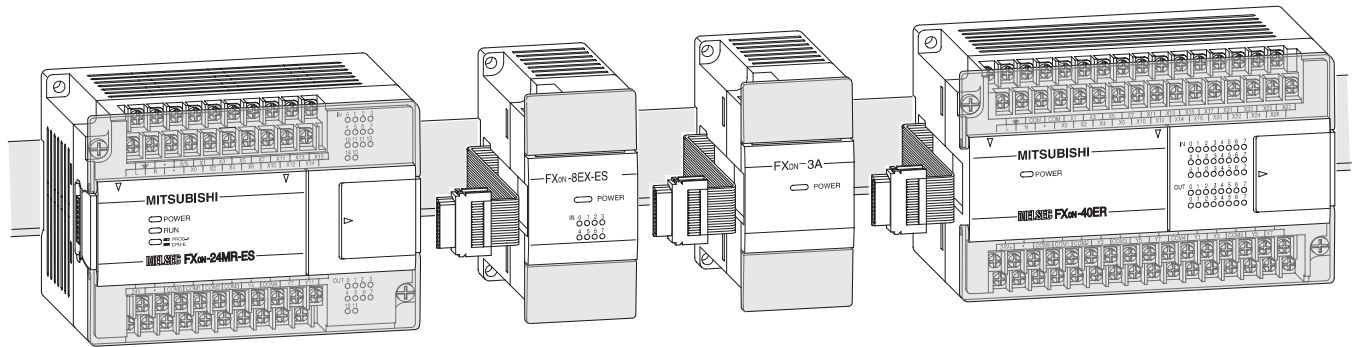

Compact extension units

FX0N FX2N

Module type	Inputs	Outputs	Output type
FX0N-40ER-ES/UL	24	16	Relay
FX0N-40ER-DS	24	16	Relay
FX0N-40ET-DSS	24	16	Transistor

Module type	Inputs	Outputs	Output type
FX2N-32ER-ES/UL	16	16	Relay
FX2N-32ET-ESS/UL	16	16	Transistor
FX2N-48ER-ES/UL	24	24	Relay
FX2N-48ET-ESS/UL	24	24	Transistor
FX2N-48ER-DS	24	24	Relay
FX2N-48ET-DSS	24	24	Transistor

Modular extension units

FX0N FX2N

Module type	Inputs	Outputs	Output type
FX0N-8EX-ES/UL	8	—	—
FX0N-16EX-ES/UL	16	—	—
FX0N-8EYR-ES/UL	—	8	Relay
FX0N-8EYT-ESS/UL	—	8	Transistor
FX0N-16EYR-ES/UL	—	16	Relay
FX0N-16EYT-ESS/UL	—	16	Transistor
FX0N-8ER-ES/UL	4	4	Relay

Module type	Inputs	Outputs	Output type
FX2N-16EX-ES/UL	16	—	—
FX2N-16EYR-ES/UL	—	16	Relay
FX2N-16EYT-ESS/UL	—	16	Transistor

Compact Extension Units

☑ FX0N ☑ FX2N

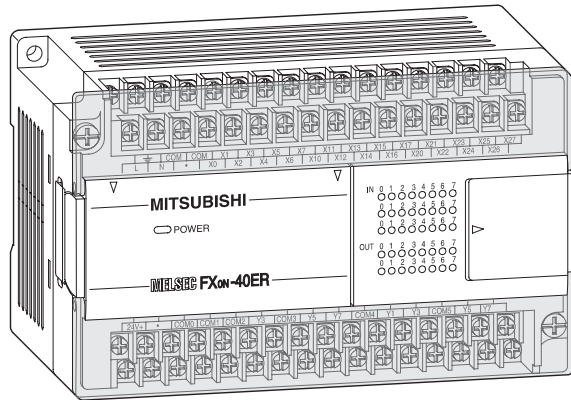

Extension Units FX0N

The FX0N series extension units are available with 40 input/output points. It is possible to choose between relay and transistor output type.

Special features:

- LEDs for indicating the input and output status
- MELSEC FX2N series compatible
- Integrated service power supply with up to 200 mA capacity

Specifications	FX0N-40 ER-ES/UL	FX0N-40 ER-DS	FX0N-40 ET-DSS
Electrical data			
Integrated inputs/outputs	40	40	40
Power supply	AC range (+10%, -15%)	AC 100 – 240 V	—
	Frequency at AC	50/60 (±10%) Hz	—
	DC range (+20%, -15%)	—	DC 24 V
Max. input apparent power	40 VA	20 W	20 W
Inrush current at ON	100 V AC	30 A / 5 ms	—
	200 V AC	50 A / 5 ms	—
	24 V DC	—	60 A / 50 μs
Allowable momentary power failure time	ms	10	10
External service power supply (24 V DC)	mA	200	—
Inputs			
Integrated inputs	24	24	24
Min. current for logical 1	mA	3.5	3.5
Max. current for logical 0	mA	1.5	1.5
Response time	For all base units of the MELSEC FX0N series values: 10 ms (at time of shipment)		
Outputs			
Integrated outputs	16	16	16
Output type	Relay	Relay	Transistor
Max. switching voltage	Generally for relay version: < 264 V AC, < 30 V DC; for transistor version: 5 – 30 V DC		
Max. output current	- per output	A	2
	- per group*	A	—
Max. switching power	- inductive load	VA	80
	- lamp load	W	100
Response time	ms	10	< 0.2
Life of contacts (switching times)	For all extension units of the MELSEC FX0N series values: 3000000 at 20 VA; 1000000 at 35 VA; 200000 at 80 VA		
Mechanical data			
Weight	kg	0.6	0.6
Dimensions (W x H x D)	mm	150 x 90 x 87	150 x 90 x 87
Order information	Art. no.	60012	55955
			55954

* This limitation applies only per reference terminal for each group, 4 and 8 outputs for relays and 2 and 4 outputs for transistors. Please observe the terminal assignments for the group identification.

Compact Extension Units

☑ FX0N ☑ FX2N

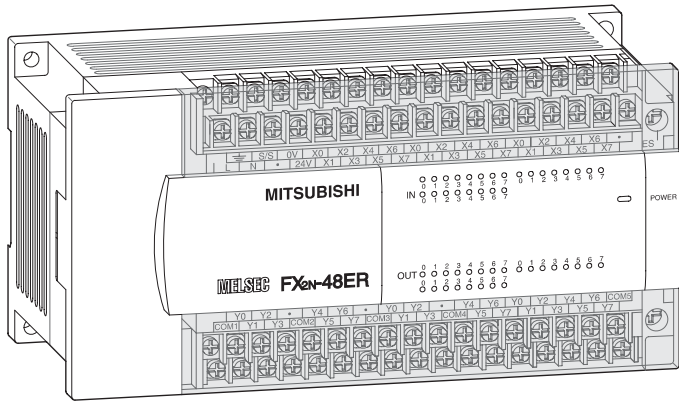

Extension Units FX2N

The FX2N series extension units are available with 32 or 48 input/output points. It is possible to choose between relay and transistor output type.

Special features:

- LEDs for indicating the input and output status
- MELSEC FX0N series compatible
- Detachable terminal blocks
- Integrated service power supply with up to 200 mA or 460 mA

Specifications	FX2N-32 ER-ES/UL	FX2N-32 ET-ESS/UL	FX2N-48 ER-DS	FX2N-48 ER-ES/UL	FX2N-48 ET-DSS	FX2N-48 ET-ESS/UL
Electrical data						
Integrated inputs/outputs	32	32	48	48	48	48
Power supply	AC range (+10%, -15%)	100 – 240 V AC	100 – 240 V AC	—	100 – 240 V AC	100 – 240 V AC
	Frequency at AC	50/60 (±10%)	50/60 (±10%)	—	50/60 (±10%)	50/60 (±10%)
	DC range (+20%, -30%)	—	—	24 V DC	—	24 V DC
Max. input apparent power	35 VA	35 VA	30 W	45 VA	30 W	45 VA
Inrush current at ON	100 V AC	50 A < 5 ms	—	50 A < 5 ms	50 A < 5 ms	50 A < 5 ms
	200 V AC	60 A < 5 ms	—	60 A < 5 ms	60 A < 5 ms	60 A < 5 ms
Allowable momentary power failure time	ms	10	10	10	10	10
External service power supply (24 V DC)	mA	250	—	250	—	460
Power supply int. bus (5 V DC)	mA	690	690	690	690	690
Inputs						
Integrated inputs	16	16	24	24	24	24
Min. current for logical 1	mA	3.5	3.5	3.5	3.5	3.5
Max. current for logical 0	mA	1.5	1.5	1.5	1.5	1.5
Response time	For all extension units of the MELSEC FX2N series values: 10 ms (at time of shipment)					
Outputs						
Integrated outputs	16	16	24	24	24	24
Output type	Art	Relay	Transistor	Relay	Transistor	Transistor
ON voltage (max.)	Generally for relay version: < 264 V AC, < 30 V DC; for transistor version: 5 – 30 V DC					
Max. output current	- per output	A	2	2	0.5	0.5
	- per group*	A	8	8	0.8	0.8
Max. switching power	- inductive load	W	80	80	12	12
	- lamp load	W	100	100	1.5	1.5
Response time	ms	10	< 0.2	10	< 0.2	< 0.2
Life of contacts (switching times)	For all extension units of the MELSEC FX2N series values: 3000000 at 35 VA; 1000000 at 80 VA; 200000 at 120 VA					
Mechanical data						
Weight	kg	0.65	0.65	0.85	0.85	0.85
Dimensions (W x H x D)	mm	150 x 90 x 87	150 x 90 x 87	182 x 90 x 87	182 x 90 x 87	182 x 90 x 87
Order information						
Art. no.	65568	65569	66633	65571	66634	65572

Modular Extension Units

FX0N FX2N

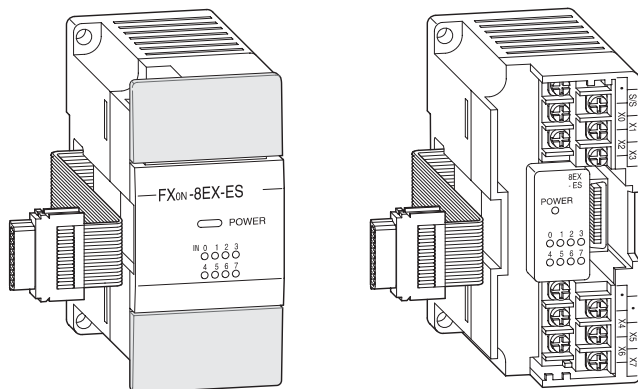

Extension Units FX0N

The FX0N series modular extension units are available with 8 or 16 input/output points. It is possible to choose between relay and transistor output type.

Special features:

- LEDs for indicating the input and output status
- MELSEC FX2N series compatible
- Vertically mounted (at 8 I/Os) or horizontally mounted (at 16 I/Os) terminal blocks with a cable guide to the upper or lower side

Specifications	FX0N-8 ER-ES/UL	FX0N-8 EX-ES/UL	FX0N-8 EYR-ES/UL	FX0N-8 EYT-ESS/UL	FX0N-16 EX-ES/UL	FX0N-16 EYR-ES/UL	FX0N-16 EYT-ESS/UL
Electrical data							
Integrated inputs/outputs	8	8	8	8	16	16	16
Power supply	All modular extension units are supplied by the base unit.						
Inputs							
Integrated inputs	4	8	—	—	16	—	—
Min. current for logical 1	mA	3.5	—	—	3.5	—	—
Max. current for logical 0	mA	1.5	—	—	1.5	—	—
Response time	For all extension units of the MELSEC FX0N series values: 10 ms						
Outputs							
Integrated outputs	4	—	8	8	—	16	16
Output type	Relay	—	Relay	Transistor	—	Relay	Transistor
Max. switching voltage	Generally for relay version: < 264 V AC, < 30 V DC; for transistor version: 5 – 30 V DC						
Max. output current	A	—	2	0.5	—	2	0.5
- per group*	A	—	—	0.8	—	—	0.8
Max. switching power	VA	80	—	80	12	—	80
- inductive load	VA	80	—	80	12	—	80
- lamp load	W	100	—	100	1.5	—	100
Response time	ms	10	10	10	< 0.2	10	10
Life of contacts (switching times)	For all extension units of the MELSEC FX0N series values: 3000000 at 20 VA; 1000000 at 35 VA; 200000 at 80 VA						
Mechanical data							
Weight	kg	0.2	0.2	0.2	0.2	0.3	0.3
Dimensions (W x H x D)	mm	43 x 90 x 87	43 x 90 x 87	43 x 90 x 87	43 x 90 x 87	70 x 90 x 87	70 x 90 x 87
Order information	Art. no.	60023	60013	60014	60016	55952	55951
		60023	60013	60014	60016	55952	55951

* This limitation applies only per reference terminal for each group, 4 and 8 outputs for relays and 2 and 4 outputs for transistors. Please observe the terminal assignments for the group identification.

Modular Extension Units

☑ FX0N ☑ FX2N

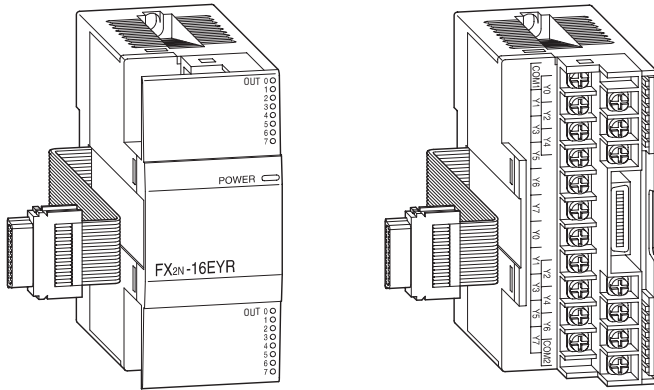

Extension Units FX2N

The FX2N series modular extension units are available with 16 input/output points. It is possible to choose between relay and transistor output type.

Special features:

- LEDs for indicating the input and output status
- MELSEC FX0N series compatible
- Especially compact design
- Vertical mounted terminal blocks with a cable guide to the upper or lower side

Specifications	FX2N-16 EX-ES/UL	FX2N-16 EYR-ES/UL	FX2N-16 EYT-ES/UL
Electrical data			
Integrated inputs/Outputs	16	16	16
Power supply	All modular extension units are supplied by the base unit.		
Inputs			
Integrated inputs	16	—	—
Min. current for logical 1	mA 3,5	—	—
Max. current for logical 0	mA 1,5	—	—
Response time	For all base units of the MELSEC FX2N series values: 10 ms (at time of shipment)		
Outputs			
Integrated outputs	—	16	16
Output type	—	Relay	Transistor
ON voltage (max.)	V Generally for relay version: < 264 V AC, < 30 V DC; for transistor version: 5 – 30 V DC		
Max. output current	- per output	A 2	0,5
	- per group*	A —	0,8
Max. switching power	- inductive load	VA 80	12
	- lamp load	W —	1,5
Response time	ms —	10	< 0,2
Life of contacts (switching times)	—	Same as base unit	—
Mechanical data			
Weight	kg 0,3	0,3	0,3
Dimensions (W x H x D)	mm 40x90x87	40 x 90 x 87	40 x 90 x 87
Order information	Art. no. 65776	65580	65581

* This limitation applies only per reference terminal for each group, 4 and 8 outputs for relays and 2 and 4 outputs for transistors. Please observe the terminal assignments for the group identification.



■ Analog Setpoint Adapter FX2N-8AV-BD

FX0N FX2N

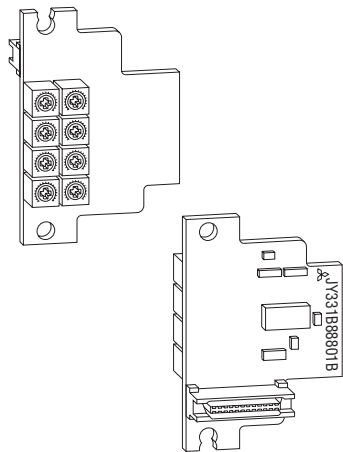

The FX2N-8AV-BD enables the user to set 8 analog setpoint values. The analog values of the potentiometers are read into the controller and used as default setpoint values for timers, counters and data registers by the user's PLC programs. Setpoint value polling and the definition of the potentiometer scales are performed in the

PLC program using the dedicated instructions VRRD/VRSC (FNC85/86). The FX2N-8AV-BD adapter board is installed in the expansion slot of the FX2N CPU. No additional power supply is required for operation.

Specifications	FX2N-8AV-BD	
General specifications	Conforms to base units	
Power supply	From base unit	
Adjusting range	8 bit	
Related I/O points	0	
Potentiometer evaluation	Via application instruction from the PLC CPU (FNC 85/86)	
Weight	kg	0.08
Dimensions (W x H)	mm	52 x 35
Order information	Art. no.	65594

■ Analog Module FX0N-3A

FX0N FX2N

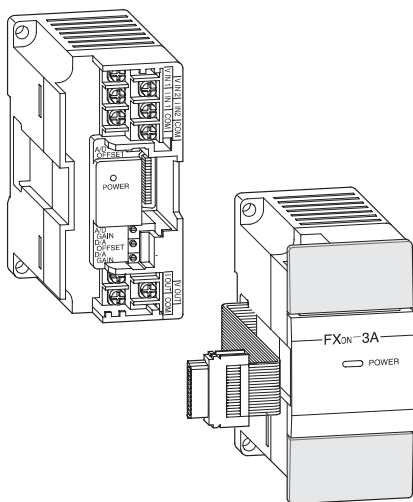

The analog module FX0N-3A provides the user with 2 analog inputs and 1 analog output. They serve for conversion of analog process signals into digital values, and vice versa.

The analog module is connected to the base unit via a protected flat cable. The connection is to the extension bus on the right side of the controller.

Specifications	FX0N-3A	
General specifications	Conforms to base units	
Dielectric withstand voltage	500 V AC for 1 minute	
Power supply	24 V DC / 90 mA (from base unit), 5 V DC / 30 mA	
Number of analog points	inputs	2
	outputs	1
Analog data	voltage	V DC 0 – 10 / 0 – 5
	current	mA DC 4 – 20
I/O resolution	20 mV / 64 μA (8 bit)	
Total accuracy	±1 %	
Conversion time	A → D / D → A	ms 0.1/point
Related I/O points	8	
Weight	kg	0.2
Dimensions (W x H x D)	mm	43 x 90 x 87
Order information	Art. no.	41790

■ Analog Output Module FX2N-4DA

FX0N FX2N
CPU vers. 2.00

These analog output modules provide the user with 4 analog outputs. The modules convert digital values from the FX0N/FX2N-controller to the analog signals required by the process.

The modules can output both current and voltage signals.

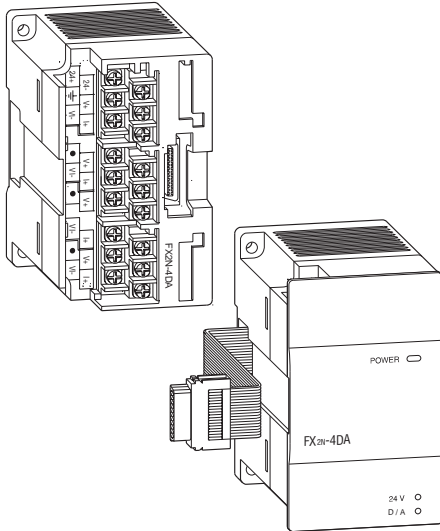

Specifications		FX2N-4DA	
General specifications		Conforms to base units	
Power supply		5 V DC / 30 mA (from base unit), 24 V DC / 200 mA	
Analog channels	inputs	—	
	outputs	4	
Analog output range		-10 V DC – +10 V DC / 0 mA – +20 mA	
External load	voltage output	2 k Ω – 1 M Ω	
	current output	< 500 Ω	
Analog data	voltage	V	± 10
	current	mA	0 – 20
Resolution		5 mV / 20 μ A (11 bit + sign)	
Overall accuracy		$\pm 1\%$	
Conversion speed	analog \rightarrow digital	ms	—
	digital \rightarrow analog	ms	2.1 for 4 channels
Related I/O points		8	
Weight		kg	0.3
Dimensions (W x H x D)		mm	55 x 90 x 87
Order information		Art. no.	65586

■ Analog Input Module FX2N-4AD

FX0N FX2N
CPU vers. 2.00

The analog input module FX2N-4AD provides the user with 4 analog inputs. The module converts analog process signals into digital values which are further processed by the MELSEC FX0N/FX2N controller.

The actual values or mean values over several measurements may be output.

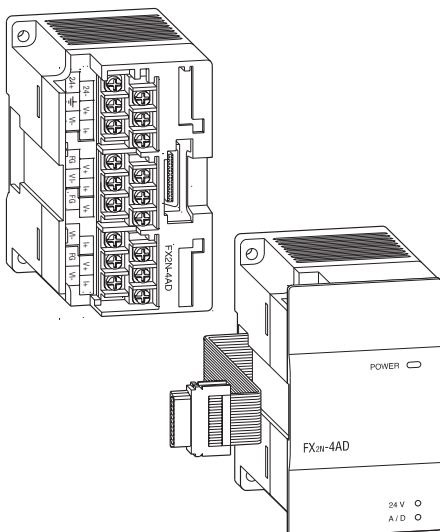

Specifications		FX2N-4AD	
General specifications		Conforms to FX2N base units	
Power supply		5 V DC / 30 mA (from base unit), 24 V DC / 50 mA	
Analog points	inputs	4	
	outputs	—	
Analog input range		-10 V DC – +10 V DC / -20 mA – +20 mA / 4 – 20 mA	
Input resistance	voltage input	k Ω	200
	current input	Ω	250
Analog data	voltage	V	± 10
	current	mA	± 20
Resolution		5 mV / 20 μ A (11 bit + sign)	
Overall accuracy		$\pm 1\%$	
Conversion speed	analog \rightarrow digital	15 per channel / 60 per 4 channels (high-speed)	
	digital \rightarrow analog	ms	—
Related I/O points		8	
Weight		kg	0.3
Dimensions (W x H x D)		mm	55 x 90 x 87
Order information		Art. no.	65585

■ Analog Input Module for Thermo Elements FX2N-4AD-TC

FX0N FX2N
CPU vers. 2.00

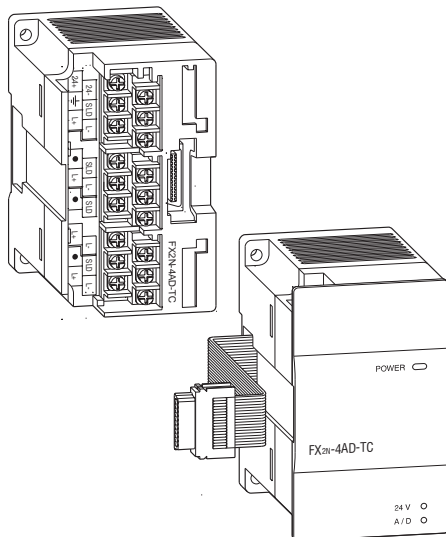

This special function module FX_{2N}-4AD-TC is used for processing temperatures. It has 4 independent inputs for detecting signals from thermocouples of types J and K. The type of thermocouple can be chosen independently for each point.

The electrical magnitude at an input is converted into a digital numerical value with a sign. The converted value is stored by the PLC in a memory address, so-called buffer memory, in the module and then converted. It is also possible to calculate

a mean value from a predetermined number of measurements in order to obtain stable digital results.

The number of measurements must be transferred by the PLC program to a buffer memory of the special function module. The value determined is available in another memory address.

Specifications	FX _{2N} -4AD-TC	
General specifications	Conforms to FX _{2N} base units	
Power supply	5 V DC / 30 mA (from base unit), 24 V DC / 50 mA	
Analog inputs	4 (K or J type)	
Compensated temperature range	°C	-100 – +600 (J type) / -100 – +1200 (K type)
Digital output	-1000 – +6000 (J type) / -1000 – +12000 (K type)	
Resolution	°C	0.3 (J type) / 0.4 (K type)
Overall accuracy	±0.5 %	
Conversion speed	ms	240 per channel (±2 %)
Related I/O points	8	
Weight	kg	0.3
Dimensions (W x H x D)	mm	55 x 90 x 87
Order information	Art. no.	65588

■ Analog Input Module for Pt100 Inputs FX2N-4AD-PT

FX0N FX2N
CPU vers. 2.00

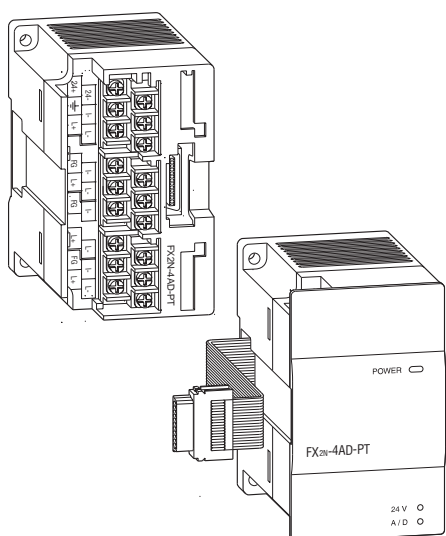

The analog input module FX_{2N}-4AD-PT permits the connection of four Pt100 sensors to the FX controller.

The respective temperatures can be read out either in °C or °F.

Specifications	FX _{2N} -4AD-PT	
General specifications	Conforms to FX _{2N} base units	
Power supply	5 V DC / 30 mA (from base unit), 24 V DC / 50 mA	
Analog inputs	4 (Pt100 sensors)	
Compensated temperature range	°C	-100 – +600
Digital output	-1000 – 6000 (12 bit conversion)	
Resolution	°C	0.2
Overall accuracy	±1 % over full linear range	
Conversion speed	ms	15 for 4 channels
Related I/O points	8	
Weight	kg	0.3
Dimensions (W x H x D)	mm	55 x 90 x 87
Order information	Art. no.	65587

High-Speed Counter FX2N-1HC

FX0N FX2N
CPU vers. 2.00

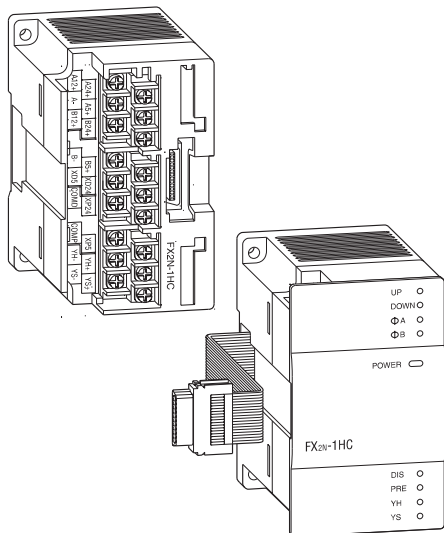

In addition to the internal high-speed MELSEC FX counters, the high-speed counter module FX2N-1HC provides the user with an external hardware counter. It counts 1- or 2-phase pulses up to a frequency of 50 kHz. The counting range covers either 16 or 32 bit.

The two integrated transistor outputs can be switched independently of one another by means of internal comparison functions. Hence, simple positioning tasks can also be realized economically. In addition, the FX2N-1HC can be used as a ring counter.

Specifications	FX2N-1HC	
General specifications	Conforms to FX2N base units	
Signal level	5, 12, 24 V DC / 7 mA	
Power supply	5 V DC / 90 mA from base unit	
Counter inputs	2 (1 phase) oder 1 (2 phase)	
Max. counting frequency	kHz	50
Input format	Bit	16, 32
Typ of counter	Up/down counter, ring counter	
Counting range	16 Bit	-2147483648 – +2147483647
	32 Bit	0 – 65535
Output type	2 x transistor (5 – 24 V DC; 0.5 A)	
Related I/O points	8	
Weight	kg	0.3
Dimensions (W x H x D)	mm	55 x 90 x 87
Order information	Art. no.	65584

Single Axes Positioning Module FX2N-1PG-E

FX0N FX2N
CPU vers. 2.00

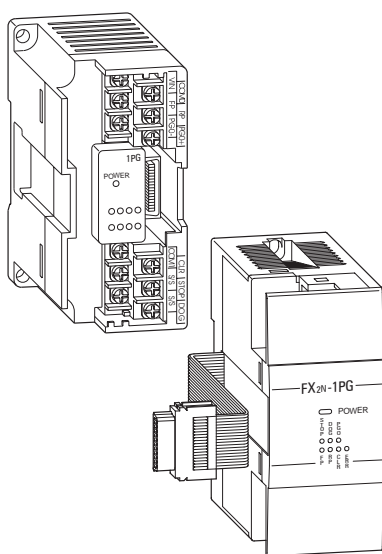

The positioning module FX2N-1PG-E is an extremely efficient single-axis positioning module for controlling either step drives or servo drives (by external regulator) with a pulse chain. It is very suitable for achieving accurate positioning in combination with the MELSEC FX series. The configuration and allocation of the position data are carried out directly via the PLC program. A very wide range of manual and automatic functions are available to the user.

Further special features are:

- Possibility of absolute or relative positioning
- 7 different operation functions, such as jog mode, zeroing, variable speeds, etc.
- Separate programming units and operator panels are not required.
- The speed increase or decrease can be set either automatically or manually.

Specifications	FX2N-1PG-E	
General specifications	Conforms to FX2N base units	
Signal level for digital inputs	24 V DC / 7–40 mA	
Power supply	5 – 24 V DC / 60 mA	
Accessible axes	1	
Output frequency	pulse/s	10 – 100 000
Related I/O points	8	
Weight	kg	0.3
Dimensions (W x H x D)	mm	43 x 90 x 87
Order information	Art. no.	65583

■ Active Data Interface FX0N-232ADP

FX0N FX2N
CPU vers. 2.00

The additional RS232C interface FX0N-232ADP permits active communication between the PLC and surrounding RS232C peripherals. All operands can be sent or received via this interface.

Devices can be transmitted via this interface. A program transfer or the connection of a MAC terminal is not possible.

The module is suitable for the connection of printers, bar code readers, PCs and other PLC systems. The communication is handled by the PLC program using the RS instruction.

The connection is to the communications bus on the left side of the controller. The internal serial RS422 interface is also fully available.

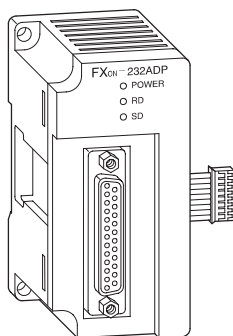

Specifications	FX0N-232ADP
General specifications	Conforms to FX0N/FX2N base units
Interface	RS232 with 25 pole D-SUB compact plug (photocoupler isolated)
Power supply	5 V DC / 200 mA (from base unit)
Communication speed	Bit/s 300, 600, 1200, 2400, 4800, 9600, 19200
Communication distance	m Max. 15
Communication cable	Shielded cable
Communication mode	Half duplex
Protocols	Non-protocol mode / free programmable via PLC
Format	7 or 8 bits, parity 1 or 0, 1 or 2 stop bit
Related I/O points	—
Weight	kg 0.2
Dimensions (W x H x D)	mm 43 x 90 x 68
Order information	Art. no. 42211

■ Interface Module FX2N-232IF

FX0N FX2N
CPU-Vers. 2.00

The FX2N-232IF module provides an RS-232C interface for serial data communications with the MELSEC FX2N/FX0N. Communication with PCs, printers, modems, barcode readers etc. is handled by the PLC program using FROM/TO instructions.

The send and receive data are stored in the FX2N-232IF's own buffer memory. Changes at the user program are not possible via this interface.

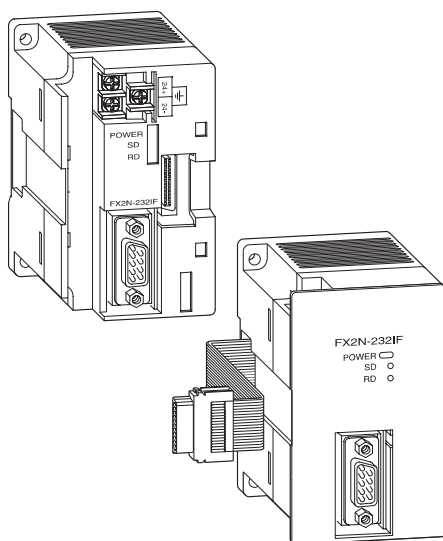

Specifications	FX2N-232IF
General specifications	Conforms to FX2N base units
Interface	RS232 with 9 pole D-SUB connector (photocoupler isolation)
Power supply	5 V DC / 40 mA (from base unit), 24 V DC / 80 mA
Communication speed	bit/s 300, 600, 1200, 2400, 4800, 9600, 19200
Communication distance	m Max. 15
Communication cable	Shielded cable
Communication mode	Full duplex
Protocols	Non protocol mode / start stop synchronisation
Format	7 or 8 data bits, parity 1 or 0, 1 or 2 stop bit
Send and receive buffer	512 byte each
Related I/O points	8
Weight	kg 0.3
Dimensions (W x H x D)	mm 55 x 90 x 85
Order information	Art. no. 66640

■ Interface Adapter FX2N-232BD

FX0N FX2N

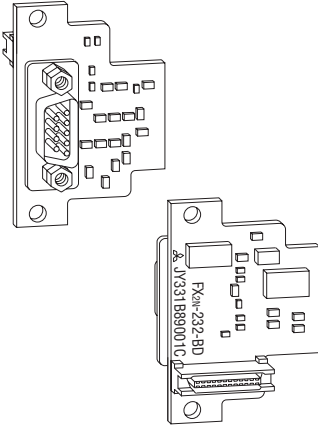

The FX2N-232BD interface adapter board provides an RS-232C interface for serial data communications with the MELSEC FX2N. Data and programmes can be transferred with the standard RS-232 protocol. The unit's integrated automatic parameter setting facility also makes it possible to configure a modem – for example for remote programming and maintenance tasks. Data can be transferred directly to other serial peripherals using the RS dedicated

instruction. Connected programming systems are identified automatically.

The adapter board is installed in the expansion slot provided for it in the FX2N base unit.

If the adapter is used no other adapters can be used.

If additional RS232C interfaces are required, the FX2N-232IF can be used for extension.

Specifications		FX2N-232BD
General specifications		Conforms to FX2N base units
Interface		RS232 with 9 pole D-SUB connector
Power supply		5 V DC / 60 mA (from base unit)
Communication speed	bit/s	300,600,1200,2400,4800,9600,19200
Communication distance	m	Max.15
Communication mode		Half duplex
Protocols		Free programmable via PLC / non-protocol mode / protocol 1 or 4
Related I/O points		—
Weight	kg	0,08
Dimensions (W x H x D)	mm	35 x 54 x 22
Order information		Art. no. 65596

■ Interface Adapter FX2N-422BD

FX0N FX2N

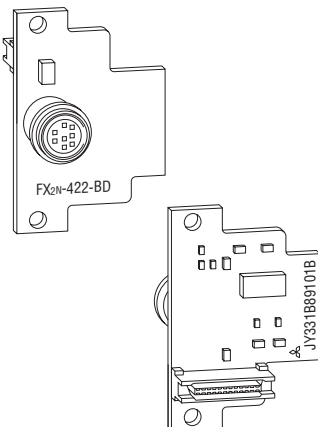

The FX2N-422BD interface adapter board provides a second RS-422 interface for connection of an additional device to the controller (programming unit or operator terminal).

In addition to programming the PLC the main applications for this interface include production data logging, process visualisation and man-machine communication.

If one programming unit is already connected to the integrated RS-422 interface it

is not possible to connect a second one to the FX2N-422BD interface adapter. It is possible to connect two control units, however.

The adapter is installed in the expansion slot provided for it in the FX2N base unit.

No additional adapter boards can be used when this unit is installed.

Specifications		FX2N-422BD
General specifications		Conforms to FX2N base units
Interface		RS422 8 pole mini DIN connector
Power supply		5 V DC / 60 mA (from base unit)
Communication distance	m	Max.50
Communication mode		Half duplex
Protocols		Free programmable via PLC
Related I/O points		—
Weight	kg	0.08
Dimensions (W x H x D)	mm	35 x 54 x 22
Order information		Art. no. 65595



The MELSECNET/MINI Network

Data communications

MELSECNET/MINI enables fast data exchange with a variety of devices. Equipment you can integrate in this network type includes:

- Remote digital I/Os
- Analog I/Os
- High-speed counters
- Remote intelligence modules (e.g. FX0N/FX2N)
- Frequency inverters (FR-A 540)
- Third-party equipment, e.g. FESTO/SMC

Structure

The network's ring topology enables a very large maximum coverage:

- Max. 1700 m with shielded twisted-pair cabling
- Max. 10000 m with shielded twisted-pair cabling combined with fibre-optics cables

Cable types

The network supports a variety of different cable types as communications media:

- Shielded twisted-pair
- Acrylic fibre-optics cable (max. 50 m/segment)
- Glass fibre-optics cable SI200/250 μm (max. 1000 m/segment)
- Glass fibre-optics cable GI50/125 μm (max. 2000 m/segment)

Data exchange

This network can transport a variety of different data without any problems, including both digital and analog data.

An FX0N/FX2N controller configured as a slave can exchange (transmit and receive) up to 28 data words with the master PLC (AnS, QnAS).

Administration

The programming software packages MELSEC MEDOC *plus* and MELSEC MINI-P make installation and set-up simple and trouble-free.

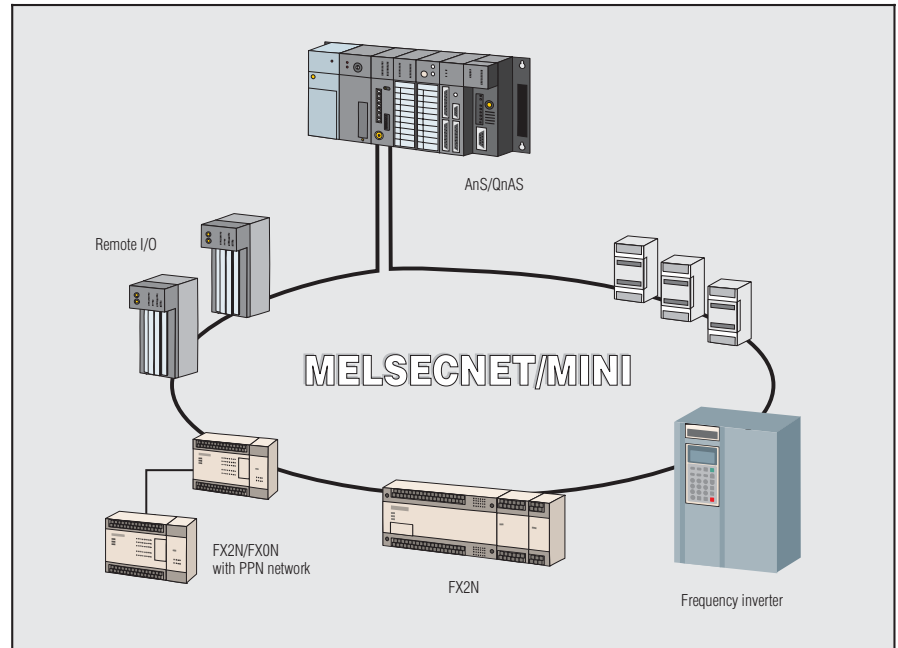

Specifications			Electrical	Optical		
Cable type			Shielded twisted-pair	Acrylic fibre optic	Glass fibre SI type	Glass fibre GI type
Communications	rate	MBit/s	1.5	1.5	1.5	1.5
	distance between 2 stations	m	100	50	1000	2000
	total coverage	m	≤ 1700	≤ 850	≤ 6000	≤ 10000
Media	internal resistance (at 20 °C)	Ω	≤ 88 / km	—	—	—
	electrostatic capacity	nF	≤ 60 / km	—	—	—
	impedance (100 kHz)	Ω	110 (±10)	—	—	—
	transmission losses		—	≤ 260 dB / km	≤ 12 dB / km	≤ 3 dB / km
	inner/outer diameter	μm	—	980 / 1000	200 / 250	50 / 125

Connectors

Connection system	RG59	CA9104AP	CA9003	CA9003S
-------------------	------	----------	--------	---------

Order information	Art. no.	17530	9546	29603
-------------------	----------	-------	------	-------

Recommended shielded twisted-pair cabling (2 pairs): Lappkabel Unitronic Li2YCY (TP) paired (up to 100 m) or Unitronic Li2YCY (TP) finely-stranded (up to 50 m)

■ Communications Module FX0N-16NT

☑ FX0N ☑ FX2N

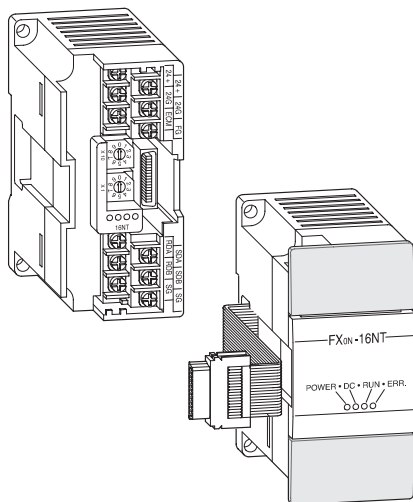

The communications module FX0N-16NT enables the user to connect to the MELSECNET/MINI with a superior A system as master CPU. This gives him access to the network of all MELSEC PLC systems and frequency inverters and to additional products from other suppliers.

Thus the network is expandable via the digital inputs/outputs of the FX modules to a maximum of 512 I/Os. The connection is to the extension bus on the right side of the controller.

Specifications		FX0N-16NT
General specifications		Conforms to FX0N base units
Dielectric withstand voltage		500 V AC for one minute
Power supply		24 V DC / 60 mA (from external power module)
Communication speed	Mbit/s	1.5
Communication distance	m	50 at 0.2 – 0.5 mm ² 100 at > 0.5 mm ²
Communication cable		Shielded twisted pair 0.5 mm ²
Communication mode		Bit transformation
Related I/O points		16
Weight	kg	0.2
Dimensions (W x H x D)	mm	43 x 90 x 87
Order information	Art. no.	41819

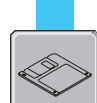
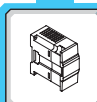
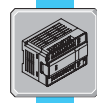
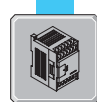

■ Communications Modules for MELSECNET/MINI FX-16NP and FX-16NT

FX0N FX2N
CPU-Vers. 2.00

These communications modules permit the linking of programmable logic controllers of the MELSEC FX0N/FX2N series as a local station in the MELSECNET/MINI with a superior A system as master CPU.

For the connection of these modules to the FX0N or FX2N series the adapter FX2N-CNV-IF is needed.

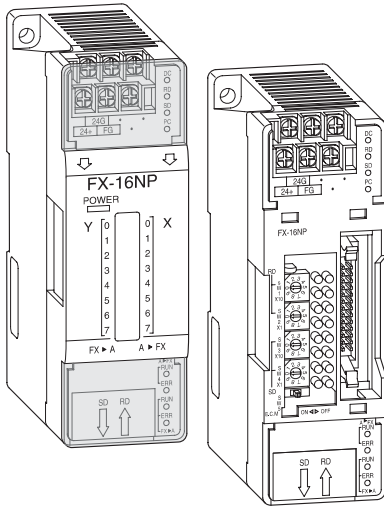

Specifications	FX-16NP	FX-16NT
General specifications	Conforms to FX base units	
Power supply	5 V DC / 80 mA (from base unit), 24 V DC / 120 mA	
Master module	AJ71PT32-S3	A(1S)J71PT32-S3 or A2CCPU
Communications modules within network	Max. 32	Max. 32
Data words	—	—
Transformed bits	8 sent / 8 received	8 sent / 8 received
Related I/O points	24	24
I/O refresh time	ms	3–4
Communication speed	MBit/s	1.5
Communication cable	Plastic fibre	Twisted pair
Communication distance	m	50 (at 0.2–0.5mm ²) 100 (at 0.5 mm ²)
Weight	kg	0.3
Dimensions (W x H x D)	mm	45 x 140 x 95
Order information	Art. no.	25196
		25197

■ Communications Modules for MELSECNET/MINI FX-16NP-S3 and FX-16NT-S3

FX0N FX2N
CPU-Vers. 2.00

These communications modules permit the linking of programmable logic controllers of the MELSEC FX0N-/FX2N series as a local station in the MELSECNET/MINI-S3 with a superior A system as master CPU.

processing of analog values in the network with the FX0N-/FX2N series is possible. Max. 16 of these communications modules can be integrated in a MELSECNET/MINI-S3.

In a S3 network, in addition to data exchange via digital inputs and outputs, it is also possible to transfer data words (max. 56), with the result that, for example,

For the connection of these module to the FX0N or FX2N series the adapter FX2N-CNV-IF is needed.

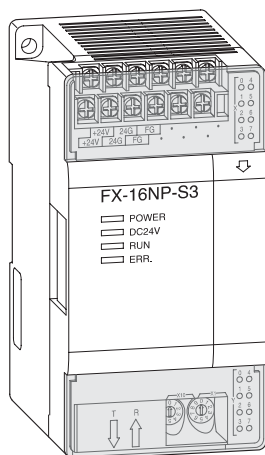

Specifications	FX-16NP-S3	FX-16NT-S3
General specifications	Conforms to FX base units	
Power supply	5 V DC / 80 mA (from base unit), 24 V DC / 100 mA	
Master station	AJ71PT32-S3	A(1S)J71PT32-S3 or A2CCPU
Communications modules within network	Max. 16	Max. 16
Data words	FX → A: 28 / A → FX: 28	FX → A: 28 / A → FX: 28
Transformed bits	8 sent / 8 received	8 sent / 8 received
Related I/O points	24	24
I/O refresh time	ms	3–4
Communication speed	MBit/s	1.5
Communication cable	Plastic fibre	Twisted pair
Communication distance	m	50 (at 0.2–0.5mm ²) 100 (at 0.5 mm ²)
Weight	kg	0.4
Dimensions (W x H x D)	mm	73 x 140 x 95
Order information	Art. no.	33714
		33715

MELSEC Peer-to-Peer Network, 1:n Network, Parallel Link

The networks in details:

Peer-to-Peer

You can integrate up to 8 programmable logic controllers in a peer-to-peer network. All stations in the network can monitor all the devices in the entire data range. However, data writing and setting and resetting of individual devices is always only performed in the specific station in question. Each network station can transfer packets of up to 64 bits and 8 data words via the network.

The maximum distance between the first and last connected stations depends on the type of adapters used:

- FX0N-485ADP: max. 500 m (CPU vers. 2.0)
- FX2N-485BD: max. 50 m

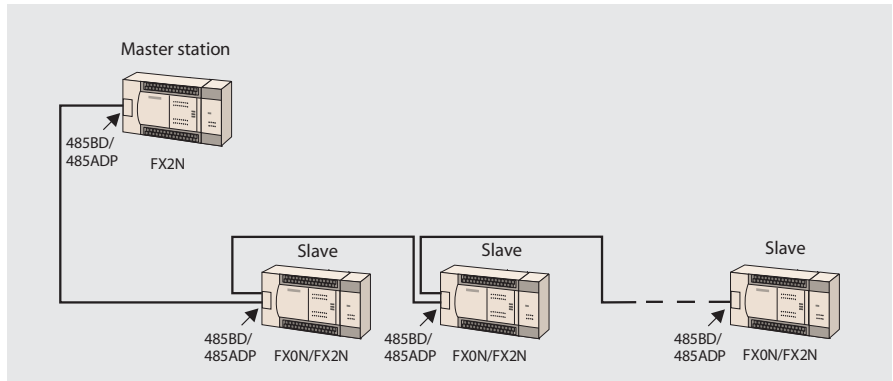

1 : n Multidrop-Netzwerk

This network is used for displaying and monitoring data from the individual stations on a connected computer.

You can connect up to 16 stations in one of these networks. The maximum distance between the first and last connected station depends on the type of adapters used:

- FX0N-485ADP: max. 500 m
- FX2N-485BD: max. 50 m

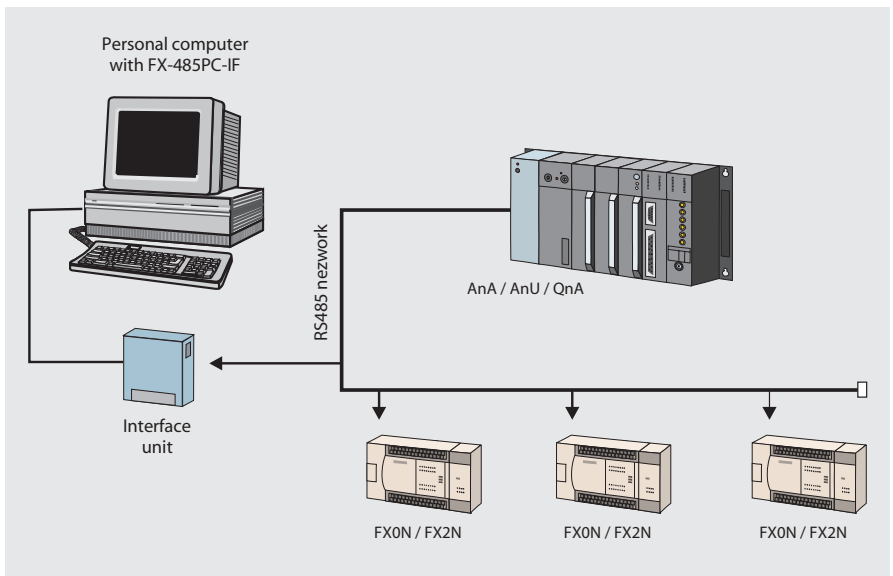

Parallel Link

As the name indicates, parallel link mode connects two programmable logic controllers with a parallel link. Data communication between the two states is performed automatically via a predefined range of relays and data registers.

The maximum distance between two stations connected by parallel link is 50 m. If the FX0N-485 ADP is used, the maximum distance will be 500 m.

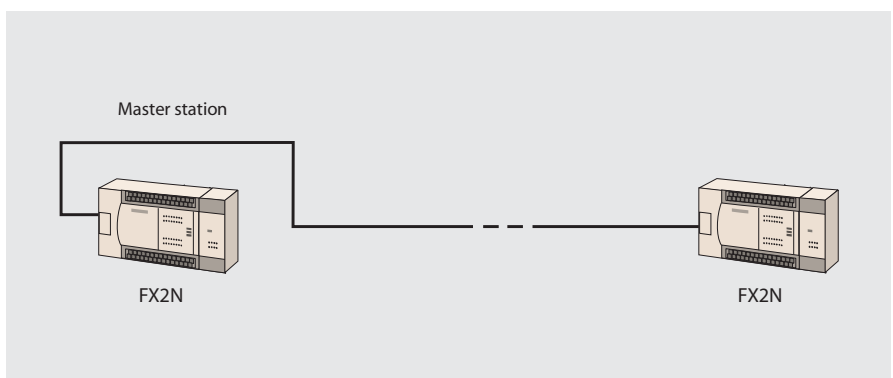

Interface Adapter FX2N-485BD

FX0N FX2N

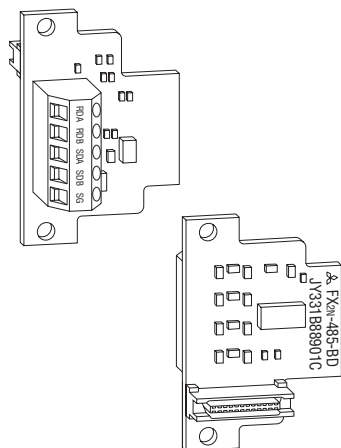

The FX2N-485BD interface adapter board provides the FX2N unit with an additional RS-485 interface. The adapter, which is simply inserted into the base unit's expansion slot, enables the configuration of RS-485 1:n multidrop, parallel link or peer-to-peer networks with FX0N/FX2N systems.

You can also transfer data directly to other RS-485 peripherals using the RS dedicated instruction.

In peer-to-peer network configurations the adapter enables active communication between the individual FX0N/FX2N controllers via the RS-485 interfaces. In 1:n multidrop networks the adapter can be used to provide communication with a host master station of the A series.

Specifications		FX2N-485BD
General specifications		Conforms to FX2N base units
Power supply		5 V DC / 60 mA from base unit
Interface		RS485 / RS422
Communication speed	bit/s	300 – 19200
Communication cable		Twisted pair
Communication distance	m	max. 50
Protocols		Protocol 1 or 4 of AJ71UC24 / no protocol / parallel link / peer-to-peer network
Related I/O points	Station	0
Weight	kg	0.08
Dimensions (W x H x D)	mm	35 x 54 x 22
Order information		Art. no. 65597

Communications Module FX0N-485ADP

FX0N FX2N

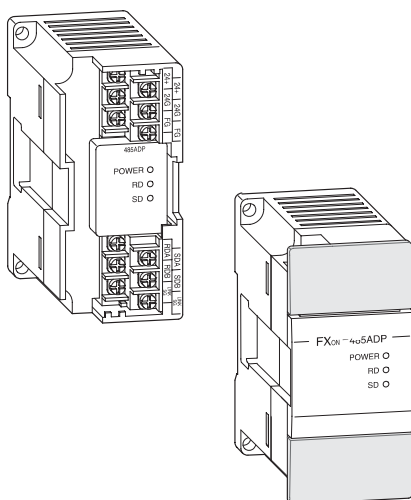

The FX0N-485ADP communications module enables the configuration of 1:n multidrop, parallel link and peer-to-peer data networks using the RS-485 interface.

Configuration of peer-to-peer data networks requires version 2.00 of the FX0N-485ADP (see p. 21 for details).

In FX0N systems the module is connected directly to the communications bus on the left-hand side of the FX0N base unit. The FX2N-CNV-BD communications adapter is required for connection to FX2N base unit.

Specifications		FX0N-485ADP
General specifications		Conforms to FX0N base units
Power supply		5 V DC / max. 30 mA (from base unit), 24 V DC / 50 mA
Interface		RS485
Communication speed	bit/s	300 – 19200
Communication distance	m	Max. 500
Communication cable		Shielded cable
Communication mode		Half duplex
Protocols		Protocol 1 and 4 of AJ71UC24
Related I/O points		—
Weight	kg	0.3
Dimensions (W x H x D)	mm	43 x 90 x 87
Order information		Art. no. 66665

■ Interface Unit for RS485 1:n Multidrop Network FX-485PC-IF

☑ FX0N ☑ FX2N

The interface unit FX-485PC-IF is used for converting interface signals. The module has an RS232C interface for connection to a PC and RS485 ports for connection to the network.

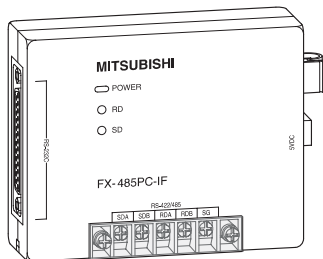

Specifications		FX-485PC-IF
General specifications		Conforms to FX2N base units
Current consumption	mA	260
Power supply		5 V DC ±5 %
Interface		RS232 / RS485
Communication speed	bit/s	300, 600, 1200, 2400, 4800, 9600, 19200
Communication cable		Shielded cable
Communication distance	m	15 (RS232) 500 (RS485)
Communication mode		Half duplex
Protocols		Protocol 1 and 4 of AJ71UC24
Weight	kg	0.3
Dimensions (W x H x D)	mm	100 x 80 x 30
Order information		Art. no. 53416

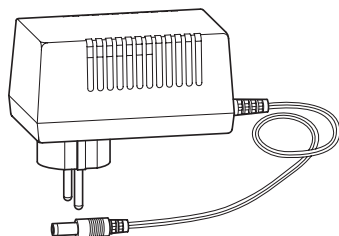

The power supply is used for the interface unit FX-485PC-IF.

Specifications		SC06 N-PG
General specifications		Conforms to FX2N base units
Power supply		5 V DC / 800 mA
Weight	kg	
Dimensions (W x H x D)	mm	
Order information		Art. no. 32630

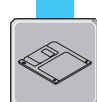
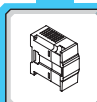
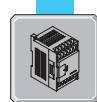

The PROFIBUS/DP Network

Data Communications

The open PROFIBUS/DP network enables extremely fast data exchange with a very wide variety of slave devices, including:

- Remote digital I/Os
- Remote intelligence PLC (FX0N, FX2N)
- Frequency inverters (FR-A 024/044, FR-A 240 and MELTRAC 140)
- Operator terminals (MAC)
- A range of other devices from third-party manufacturers

Structure

The maximum coverage of a bus segment is 1200 m (at a maximum of 93.75 kbit/s). Up to 3 repeaters are allowed. Thus the maximum distance between 2 stations is calculated with 4800 m.

Cable types

To help reduce costs PROFIBUS/DP uses RS-485 technology with simple twisted-pair cabling.

Suitable cables include the UNITRONIC BUSLD from Lappkabel and the DUE 4451 from Alcatel.

Data exchange

The PROFIBUS AJ71PB92 and A1SJ71PB92D master modules support slave device data exchange with up to 32 send bytes and 32 receive bytes. This means you can exchange a total of up to 64 bytes with a slave unit per network cycle.

Administration

In combination with the MELSEC Profi-Map configuration software the A1SJ71PB92D PROFIBUS/DP master unit gives you user-friendly plug-and-play technology. The configuration software is self-explanatory, using a graphical model for setting up the network. You simply select the slave unit (e.g. FX2N), assign the station numbers and specify where the information is stored in the Master CPU.

Of course, PROFIBUS/DP slaves from MITSUBISHI ELECTRIC can also be connected to master devices from other manufacturers.

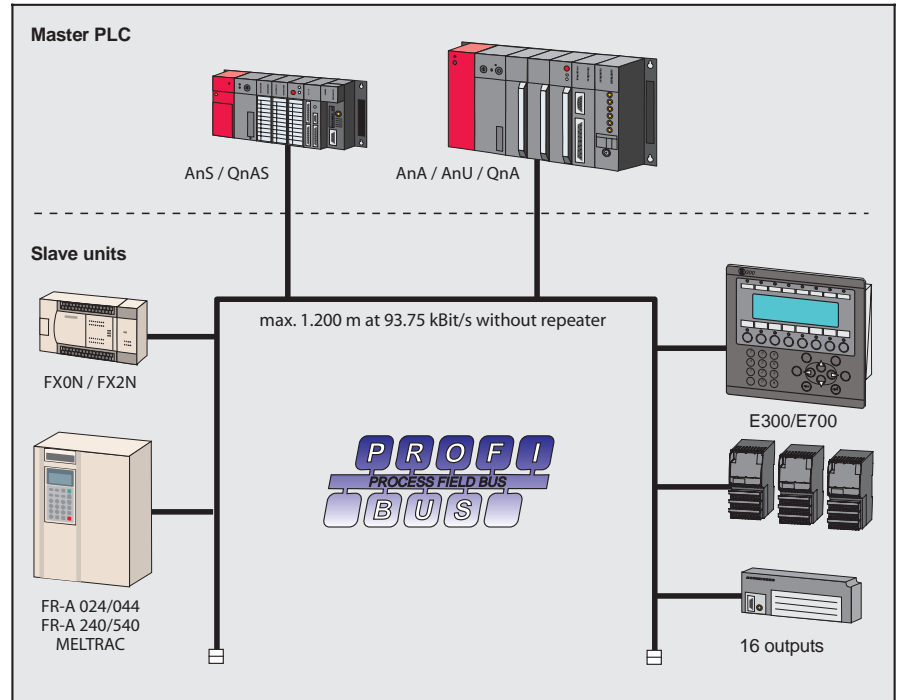

Specifications	Master AJ71PB92	Master A1SJ71PB92D	
Communications protocol	EN 50170 / DIN 19245-T3		
Cabling	Shielded twisted-pair with 24 AWG = 0,22 mm ² , impedance: 100 – 130 Ω; Shielded twisted-pair with 22 AWG = 0,34 mm ² , impedance: 135 – 165 Ω;		
Interface	RS485		
Data transfer rate	distance		
	1200 m	kbit/s	9.6 / 19.2 / 93.75
	1000 m	kbit/s	187.5
	400 m	kbit/s	500
Max total distance	200 m	kbit/s	1500
	m		12000 / 6000 / 3000 (100 m) 1500 (200 m)
Slave units per master	60		
Stations per segment	32		
Repeaters per network	3		
Accessories	ProfiCon: PROFIBUS 9-pin D-SUB plug connector for up to 12 Mbaud, art. no. 64127 or art. 87035 (see page 73); ProfiMap: configurations software for MELSEC master modules and third party devices, art. no. 102996 (see page 71)		

■ Profibus DP Slave Module FX0N-32NT-DP

FX0N FX2N

The FX0N-32NT-DP Profibus module enables you to integrate a MELSEC FX0N/FX2N system in an existing Profibus DP network. This interface module provides your FX0N or FX2N CPU with an intelligent Profibus DP link for the implementation of decentralised control tasks.

It links the system to the master PLC in the Profibus DP network for efficient and trouble-free data exchange.

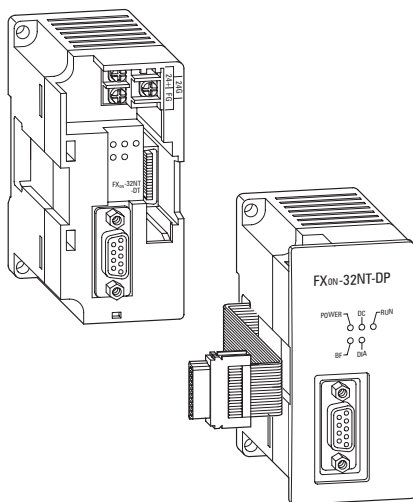

Specifications		FX0N-32NT-DP	
General specifications		Conforms to FX0N base units	
Power supply		5 V DC / max. 170 mA (from base unit), 24 V DC / 60 mA	
Interface		Profibus DP	
Communication speed	distance		
	1200 m	kbit/s	9.6 / 19.2 / 93.75
	1000 m	kbit/s	187.5
	200 m	kbit/s	1500
Communication distance	100 m	kbit/s	3000 / 6000 / 12000
		m	Max. 1200 (depends on communication speed)
Communication cable		PROFIBUS cable with 9-pin D-SUB plug	
Related I/O points		8	
Weight		kg	0.3
Dimensions (W x H x D)		mm	43 x 90 x 87
Order information		Art. no.	62125



■ Communications Adapter FX2N-CNV-IF

FX0N FX2N

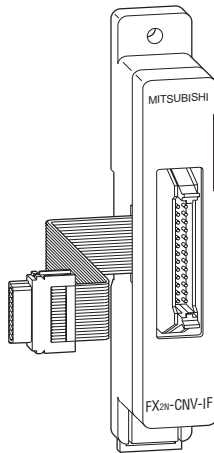

The FX2N-CNV-IF communications adapter (IF = interface) enables you to connect your FX series special function modules to FX0N/FX2N systems.

The adapter provides compatibility between the FX0N/FX2N CPU and the digi-

tal FX modules and special function modules.

Specifications	FX2N-CNV-IF	
General specifications	Conforms to FX2N base units	
Power supply	Not necessary	
Related I/O points	0	
Weight	kg	0.15
Dimensions (W x H x D)	mm	23 x 140 x 45
Order information	Art. no.	65599

■ Communications Adapter FX2N-CNV-BD

FX0N FX2N

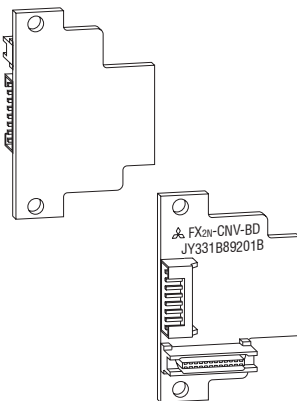

The FX2N-CNV-BD communications adapter (BD = function board) enables connection of the FX0N-232ADP and FX0N-

485ADP special function modules to the left-hand side of the FX2N base units.

Specifications	FX2N-CNV-BD	
General specifications	Conforms to FX2N base units	
Power supply	Not necessary	
Related I/O points	0	
Weight	kg	0.08
Dimensions (W x H)	mm	54 x 35
Order information	Art. no.	65598



Memory/Real-Time Clock Cassettes

FX0N FX2N

All FX0N/FX2N base units are equipped with a slot for the optional, robust FX memory cassettes. By connection of these cassettes, the internal memory of the controller is switched off and only the

program specified in the respective memory cassette is run. The program contained in the internal memory is retained due to battery buffering.

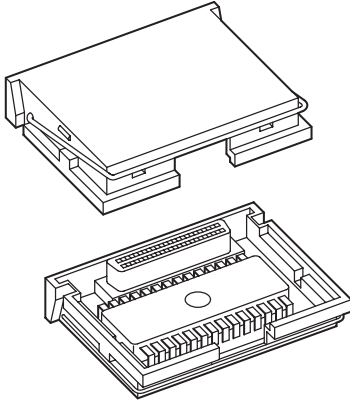

Data	FX-RAM-8	FX-EPROM-8	FX-EEPROM-4
Memory type	RAM	EPROM	EEPROM
Size	16000 steps (FX2N)	8000 steps	4000 steps
Accessory	—	—	—
Order information	Art. no. 23823	23824	23825

Data	FX-EEPROM-4C	FX-EEPROM-8	FX-EEPROM-16	FX-RTC
Memory type	EEPROM	EEPROM	EEPROM	Real-time clock
Size	4000 steps	8000 steps	16000 steps	—
Accessory	Real-time clock	—	—	Battery (optional)
Order information	Art. no. 23833	23826	65600	23831

Interface Converter CR01-R2/R4 SET and CR01-R4/R4

FX0N FX2N

This module is a signal amplifier with photocoupler isolation for RS422 signals. It is used to connect a PLC with external devices like operation panels or a personal

computer, especially when a potential isolation is required and when the wiring length takes more than 15 meters.

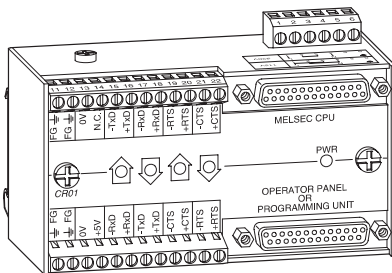

Specifications	CR01-R4/R4	CR01-R2/R4 SET
Interface conversion	RS422 ↔ RS422	RS422 ↔ RS232 (with SC09)
Order information	Art. no. 56173	56172

■ PROM Adapter FX-ROM SOC1

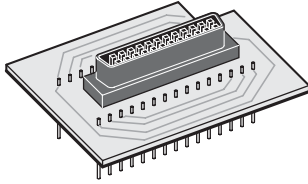

The PROM adapter is used for adapting memory cassettes to a Textool base. This socket is required if the memory cassette EPROM-8 is to be written with a

commercial EPROM loader in order, for example, to load a MEDOC program.

Data	FX-ROM SOC1	
Order information	Art. no.	27163

■ Simulation Strip: Input-SIM

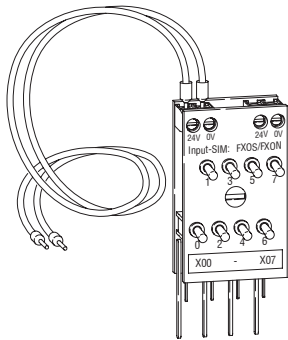

The simulation strip has 8 switches for simulating digital inputs. The strip is directly mounted to the terminals of the unit and fixed with screws to the terminal block. A cable is provided for connecting the strip to the power supply.

Two different simulation strips are available due to the differences within the terminal block between the MELSEC FX0N and FX2N series PLC. The simulation strip can be expanded with another strip for further inputs.

Data	Input-SIM: FX0S/FX0N	Input-SIM: FX2N
Switches	8	8
Application	FX0S and FX0N series	FX2N series
Dimensions (W x H x D) mm	30 x 50 x 15	30 x 50 x 15
Order information	Art. no.	65081
		66513

■ Switch Box

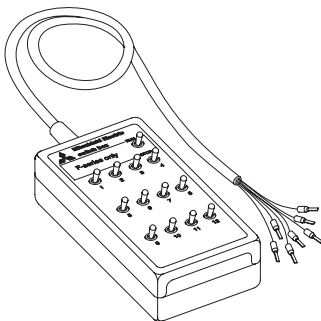

The simulation box has 12 switches for simulating digital inputs. It can be used on all controllers of the MELSEC FX family.

Data	Switch-Box	
Switches	12	
Order information	Art. no.	3386



■ Battery F2-40BL2N

FX0N FX2N

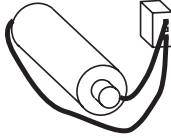

The battery F2-40BL can be used for all units of the MELSEC FX2N series. The battery buffers the internal RAM of the MELSEC FX2N PLC in the event of a voltage failure.

Data	F2-40BL
Order information	Art. no. 5142

■ Battery FX0N-40B

FX0N FX2N

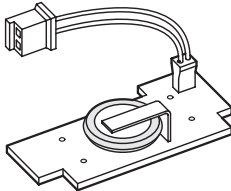

The battery FX0N-40B can be used for all units of the MELSEC FX0N series if these units are provided with a real-time clock cassette.

The battery buffers the internal real-time clock.

Data	FX0N-40B
Order information	Art. no. 44331

■ Connection Cable for Base and Compact Extension Units

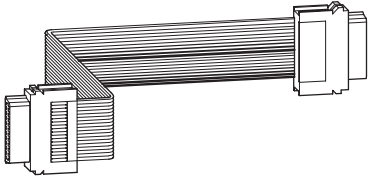

The cable is used for connection between a base unit or and a compact extension unit. This permits a multi-row arrangement of a MELSEC FX0N-/FX2N-System.

The cable must be connected to the left side of the compact extension unit.

Data		FX0N-65EC
Type		Flat cable
Length	m	0.65
Order information		Art. no. 45348



■ Base Units MELSEC FX0N

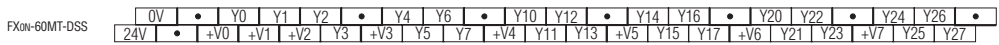
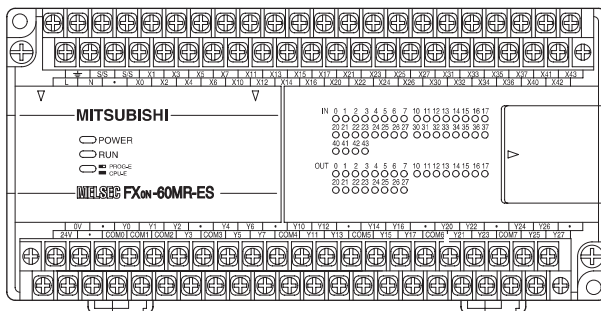
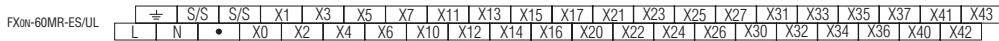
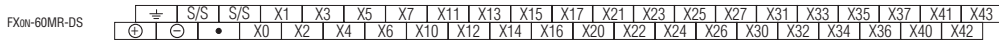
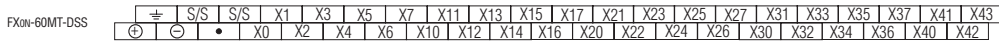
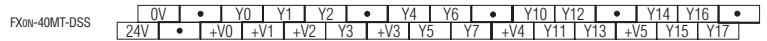
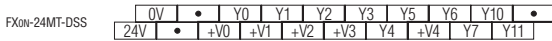
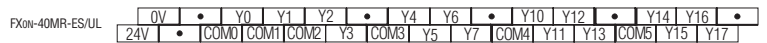
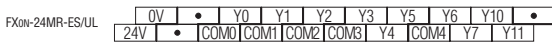
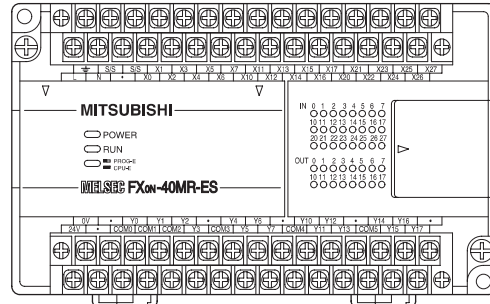
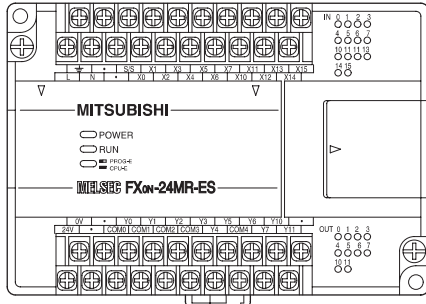
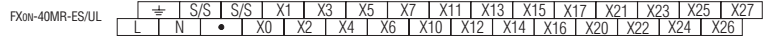
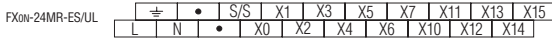
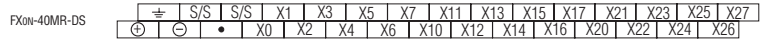
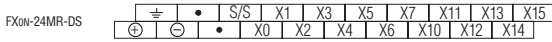
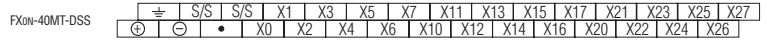
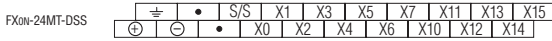

Base Units MELSEC FX2N

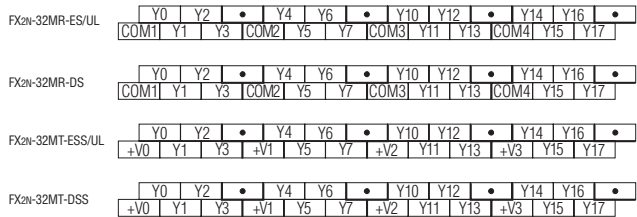
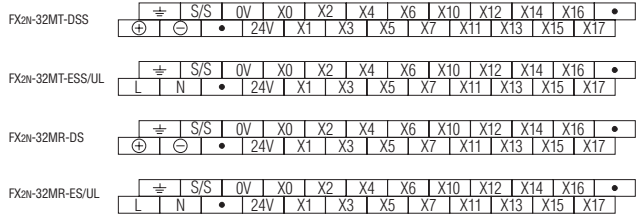
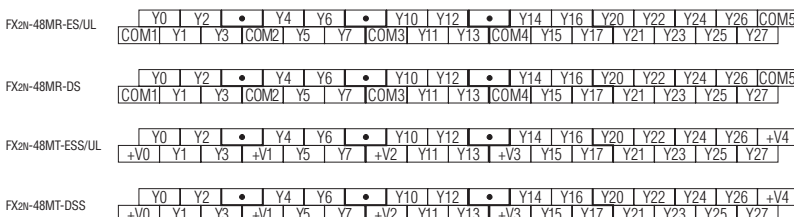
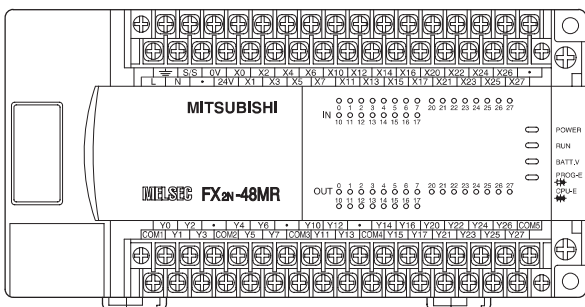
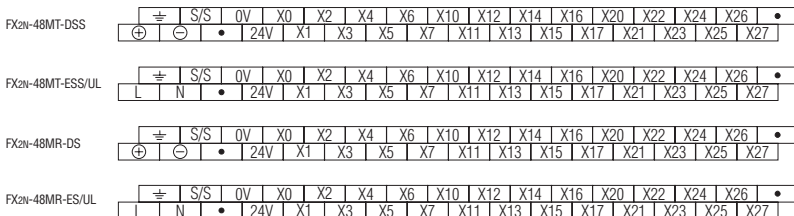
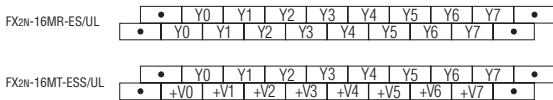
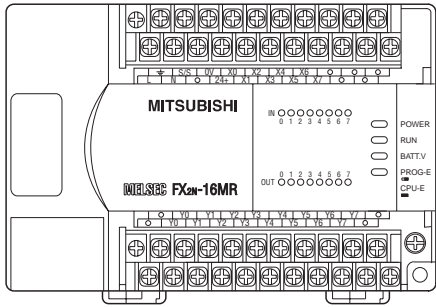
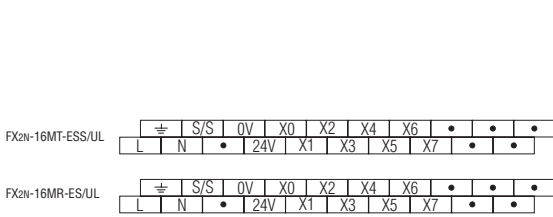



FX2n-64MT-DSS	⊕ S/S 0V 0V X0 X2 X4 X6 X10 X12 X14 X16 X20 X22 X24 X26 X30 X32 X34 X36 •
	⊖ 24V 24V X1 X3 X5 X7 X11 X13 X15 X17 X21 X23 X25 X27 X31 X33 X35 X37
FX2n-64MT-ESS/UL	⊕ S/S 0V 0V X0 X2 X4 X6 X10 X12 X14 X16 X20 X22 X24 X26 X30 X32 X34 X36 •
	L N 24V 24V X1 X3 X5 X7 X11 X13 X15 X17 X21 X23 X25 X27 X31 X33 X35 X37
FX2n-64MR-DS	⊕ S/S 0V 0V X0 X2 X4 X6 X10 X12 X14 X16 X20 X22 X24 X26 X30 X32 X34 X36 •
	⊖ 24V 24V X1 X3 X5 X7 X11 X13 X15 X17 X21 X23 X25 X27 X31 X33 X35 X37
FX2n-64MR-ES/UL	⊕ S/S 0V 0V X0 X2 X4 X6 X10 X12 X14 X16 X20 X22 X24 X26 X30 X32 X34 X36 •
	L N 24V 24V X1 X3 X5 X7 X11 X13 X15 X17 X21 X23 X25 X27 X31 X33 X35 X37

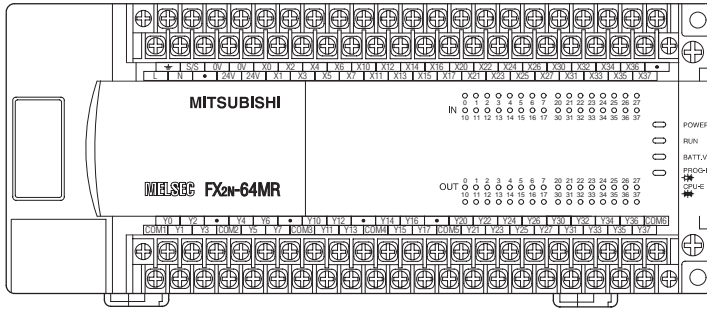

FX2n-64MR-ES/UL	Y0 Y2 • Y4 Y6 • Y10 Y12 • Y14 Y16 • Y20 Y22 Y24 Y26 Y30 Y32 Y34 Y36 COM6
	COM1 Y1 Y3 COM2 Y5 Y7 COM3 Y11 Y13 COM4 Y15 Y17 COM5 Y21 Y23 Y25 Y27 Y31 Y33 Y35 Y37
FX2n-64MR-DS	Y0 Y2 • Y4 Y6 • Y10 Y12 • Y14 Y16 • Y20 Y22 Y24 Y26 Y30 Y32 Y34 Y36 COM6
	COM1 Y1 Y3 COM2 Y5 Y7 COM3 Y11 Y13 COM4 Y15 Y17 COM5 Y21 Y23 Y25 Y27 Y31 Y33 Y35 Y37
FX2n-64MT-ESS/UL	Y0 Y2 • Y4 Y6 • Y10 Y12 • Y14 Y16 • Y20 Y22 Y24 Y26 Y30 Y32 Y34 Y36 +V5
	+V0 Y1 Y3 +V1 Y5 Y7 +V2 Y11 Y13 +V3 Y15 Y17 +V4 Y21 Y23 Y25 Y27 Y31 Y33 Y35 Y37
FX2n-64MT-DSS	Y0 Y2 • Y4 Y6 • Y10 Y12 • Y14 Y16 • Y20 Y22 Y24 Y26 Y30 Y32 Y34 Y36 +V5
	+V0 Y1 Y3 +V1 Y5 Y7 +V2 Y11 Y13 +V3 Y15 Y17 +V4 Y21 Y23 Y25 Y27 Y31 Y33 Y35 Y37

FX2n-80MT-DSS	⊕ S/S 0V 0V X0 X2 X4 X6 X10 X12 X14 X16 • X20 X22 X24 X26 • X30 X32 X34 X36 • X40 X42 X44 X46 •
	⊖ 24V 24V X1 X3 X5 X7 X11 X13 X15 X17 • X21 X23 X25 X27 • X31 X33 X35 X37 • X41 X43 X45 X47
FX2n-80MT-ESS/UL	⊕ S/S 0V 0V X0 X2 X4 X6 X10 X12 X14 X16 • X20 X22 X24 X26 • X30 X32 X34 X36 • X40 X42 X44 X46 •
	L N 24V 24V X1 X3 X5 X7 X11 X13 X15 X17 • X21 X23 X25 X27 • X31 X33 X35 X37 • X41 X43 X45 X47
FX2n-80MR-DS	⊕ S/S 0V 0V X0 X2 X4 X6 X10 X12 X14 X16 • X20 X22 X24 X26 • X30 X32 X34 X36 • X40 X42 X44 X46 •
	⊖ 24V 24V X1 X3 X5 X7 X11 X13 X15 X17 • X21 X23 X25 X27 • X31 X33 X35 X37 • X41 X43 X45 X47
FX2n-80MR-ES/UL	⊕ S/S 0V 0V X0 X2 X4 X6 X10 X12 X14 X16 • X20 X22 X24 X26 • X30 X32 X34 X36 • X40 X42 X44 X46 •
	L N 24V 24V X1 X3 X5 X7 X11 X13 X15 X17 • X21 X23 X25 X27 • X31 X33 X35 X37 • X41 X43 X45 X47

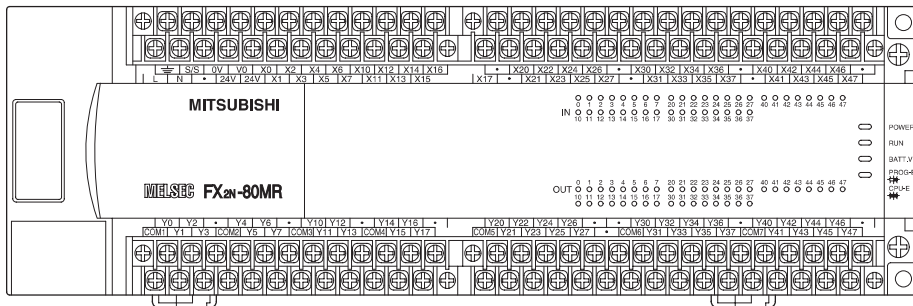

FX2n-80MR-ES/UL	Y0 Y2 • Y4 Y6 • Y10 Y12 • Y14 Y16 • Y20 Y22 Y24 Y26 • • Y30 Y32 Y34 Y36 • Y40 Y42 Y44 Y46 •
	COM1 Y1 Y3 COM2 Y5 Y7 COM3 Y11 Y13 COM4 Y15 Y17 COM5 Y21 Y23 Y25 Y27 • COM6 Y31 Y33 Y35 Y37 COM7 Y41 Y43 Y45 Y47
FX2n-80MR-DS	Y0 Y2 • Y4 Y6 • Y10 Y12 • Y14 Y16 • Y20 Y22 Y24 Y26 • • Y30 Y32 Y34 Y36 • Y40 Y42 Y44 Y46 •
	COM1 Y1 Y3 COM2 Y5 Y7 COM3 Y11 Y13 COM4 Y15 Y17 COM5 Y21 Y23 Y25 Y27 • COM6 Y31 Y33 Y35 Y37 COM7 Y41 Y43 Y45 Y47
FX2n-80MT-ESS/UL	Y0 Y2 • Y4 Y6 • Y10 Y12 • Y14 Y16 • Y20 Y22 Y24 Y26 • • Y30 Y32 Y34 Y36 • Y40 Y42 Y44 Y46 •
	+V0 Y1 Y3 +V1 Y5 Y7 +V2 Y11 Y13 +V3 Y15 Y17 +V4 Y21 Y23 Y25 Y27 • +V5 Y31 Y33 Y35 Y37 +V6 Y41 Y43 Y45 Y47
FX2n-80MT-DSS	Y0 Y2 • Y4 Y6 • Y10 Y12 • Y14 Y16 • Y20 Y22 Y24 Y26 • • Y30 Y32 Y34 Y36 • Y40 Y42 Y44 Y46 •
	+V0 Y1 Y3 +V1 Y5 Y7 +V2 Y11 Y13 +V3 Y15 Y17 +V4 Y21 Y23 Y25 Y27 • +V5 Y31 Y33 Y35 Y37 +V6 Y41 Y43 Y45 Y47

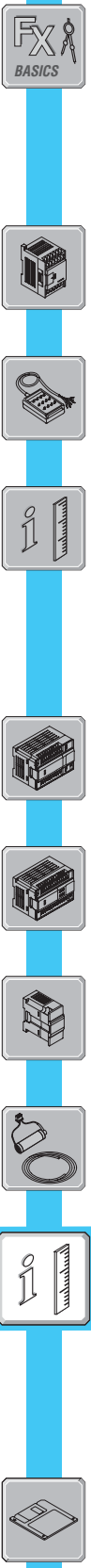
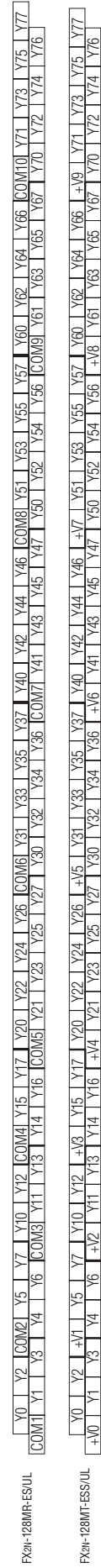
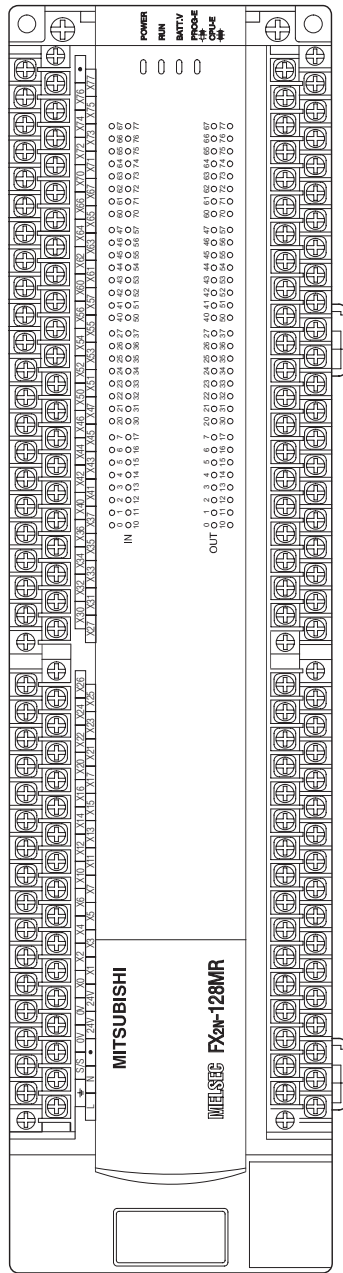

Compact Extension Units MELSEC FX0N

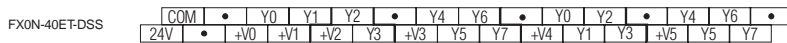
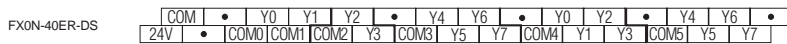
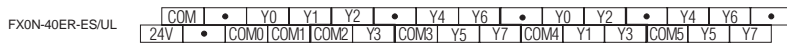
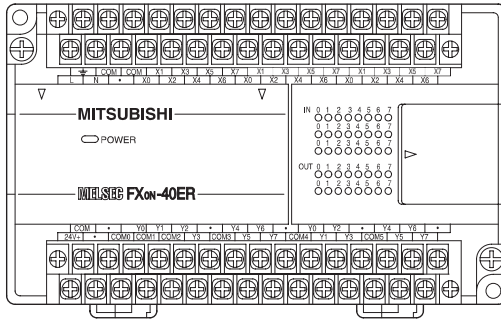
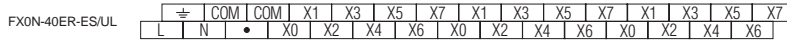
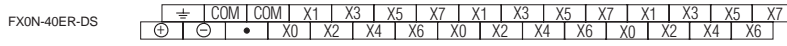
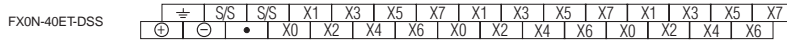

Modular Extension Units MELSEC FX0N

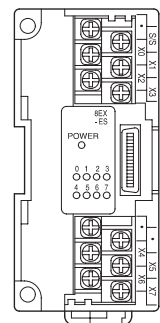
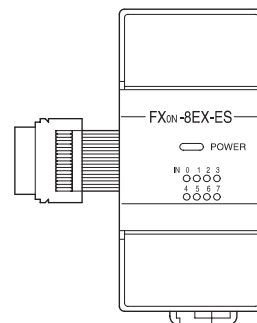
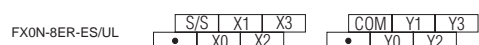
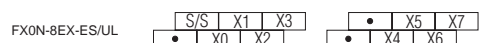
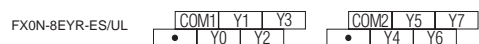
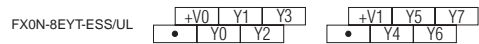
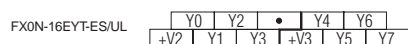
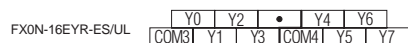
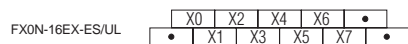
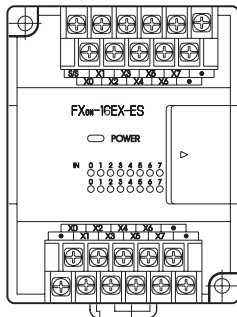
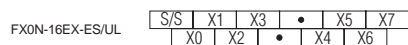
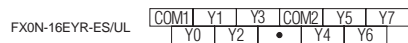
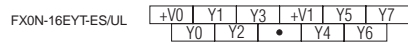

Compact Extension Units MELSEC FX2N



FX2N-32ET-ESS/UL	⊕	S/S	0V	X0	X2	X4	X6	X0	X2	X4	X6	•
	L	N	•	24V	X1	X3	X5	X7	X1	X3	X5	X7

FX2N-32ER-ES/UL	⊕	S/S	0V	X0	X2	X4	X6	X0	X2	X4	X6	•
	L	N	•	24V	X1	X3	X5	X7	X1	X3	X5	X7

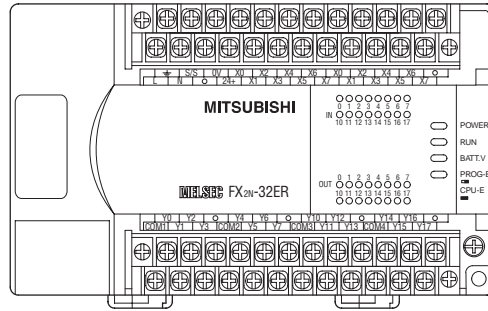

FX2N-32ER-ES/UL	Y0	Y2	•	Y4	Y6	•	Y0	Y2	•	Y4	Y6	•
	COM1	Y1	Y3	COM2	Y5	Y7	COM3	Y1	Y3	COM4	Y5	Y7

FX2N-32ET-ESS/UL	Y0	Y2	•	Y4	Y6	•	Y0	Y2	•	Y4	Y6	•
	+V0	Y1	Y3	+V1	Y5	Y7	+V2	Y1	Y3	+V3	Y5	Y7

FX2N-48ET-DS	⊕	S/S	0V	X0	X2	X4	X6	X0	X2	X4	X6	X0	X2	X4	X6	•
	⊕	⊖	•	24V	X1	X3	X5	X7	X1	X3	X5	X7	X1	X3	X5	X7

FX2N-48ET-ES/UL	⊕	S/S	0V	X0	X2	X4	X6	X0	X2	X4	X6	X0	X2	X4	X6	•
	L	N	•	24V	X1	X3	X5	X7	X1	X3	X5	X7	X1	X3	X5	X7

FX2N-48ER-DS	⊕	S/S	0V	X0	X2	X4	X6	X0	X2	X4	X6	X0	X2	X4	X6	•
	⊕	⊖	•	24V	X1	X3	X5	X7	X1	X3	X5	X7	X1	X3	X5	X7

FX2N-48ER-ES/UL	⊕	S/S	0V	X0	X2	X4	X6	X0	X2	X4	X6	X0	X2	X4	X6	•
	L	N	•	24V	X1	X3	X5	X7	X1	X3	X5	X7	X1	X3	X5	X7

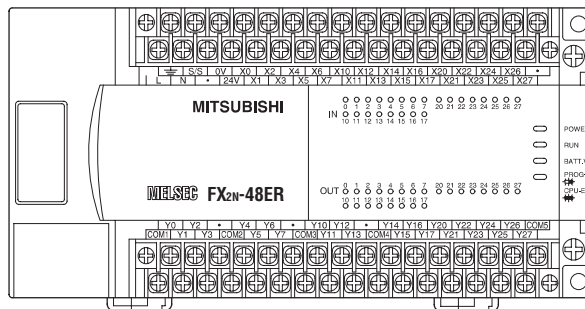

FX2N-48ER-ES/UL	Y0	Y2	•	Y4	Y6	•	Y0	Y2	•	Y4	Y6	Y0	Y2	Y4	Y6	COM5
	COM1	Y1	Y3	COM2	Y5	Y7	COM3	Y1	Y3	COM4	Y5	Y7	Y1	Y3	Y5	Y7

FX2N-48ER-DS	Y0	Y2	•	Y4	Y6	•	Y0	Y2	•	Y4	Y6	Y0	Y2	Y4	Y6	COM5
	COM1	Y1	Y3	COM2	Y5	Y7	COM3	Y1	Y3	COM4	Y5	Y7	Y1	Y3	Y5	Y7

FX2N-48ET-ES/UL	Y0	Y2	•	Y4	Y6	•	Y0	Y2	•	Y4	Y6	Y0	Y2	Y4	Y6	+V4
	+V0	Y1	Y3	+V1	Y5	Y7	+V2	Y1	Y3	+V3	Y5	Y7	Y1	Y3	Y5	Y7

FX2N-48ET-DS	Y0	Y2	•	Y4	Y6	•	Y0	Y2	•	Y4	Y6	Y0	Y2	Y4	Y6	+V4
	+V0	Y1	Y3	+V1	Y5	Y7	+V2	Y1	Y3	+V3	Y5	Y7	Y1	Y3	Y5	Y7



Modular Extension Units MELSEC FX2N



FX2N-16EX-ES/UL

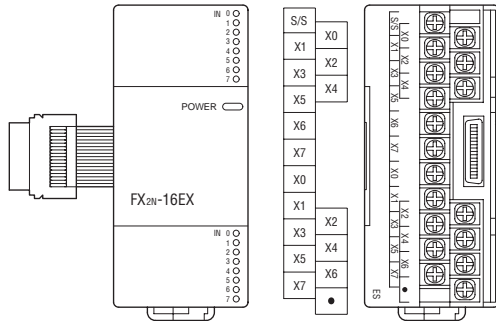

FX2N-16EYT-ESS/UL

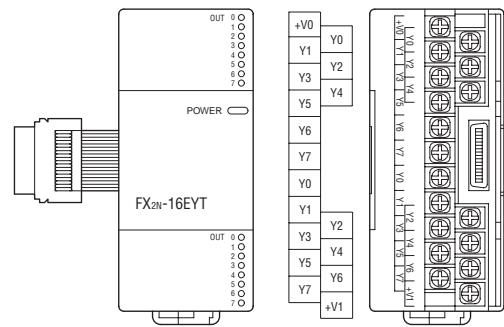

FX2N-16EYR-ES/UL

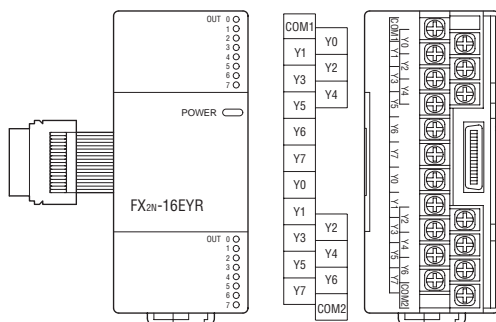

Special Function Modules MELSEC FX0N / FX2N

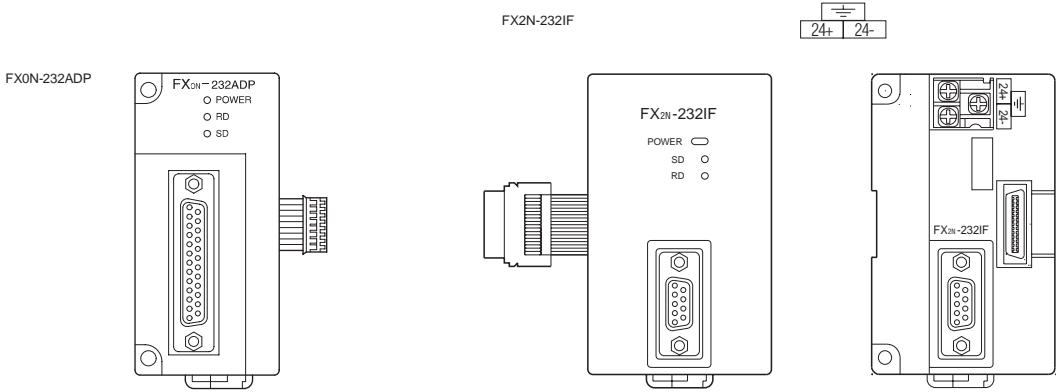
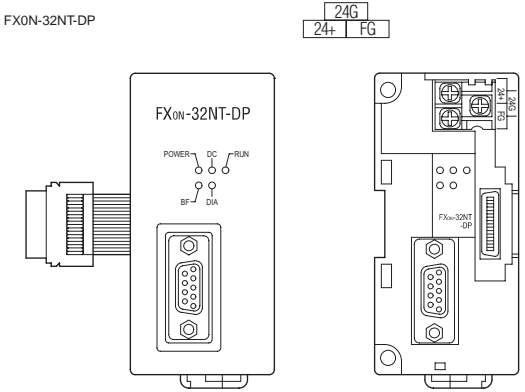
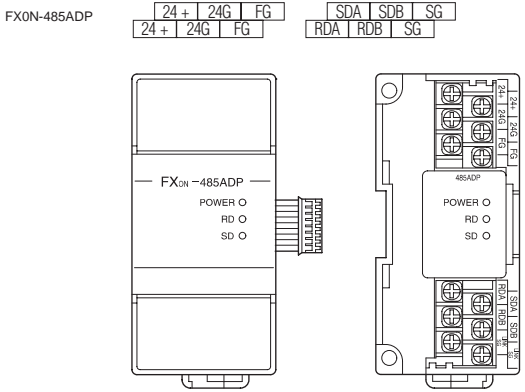
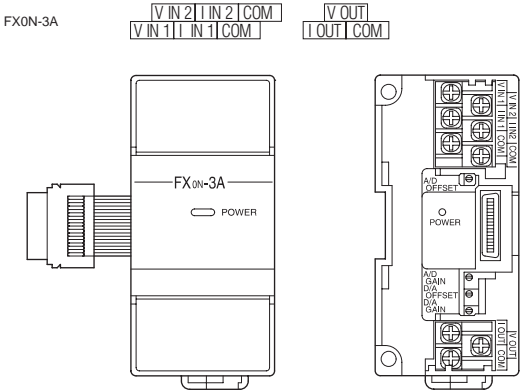
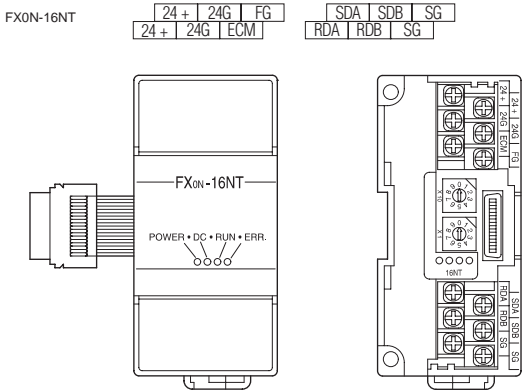



Special Function Modules MELSEC FX2N

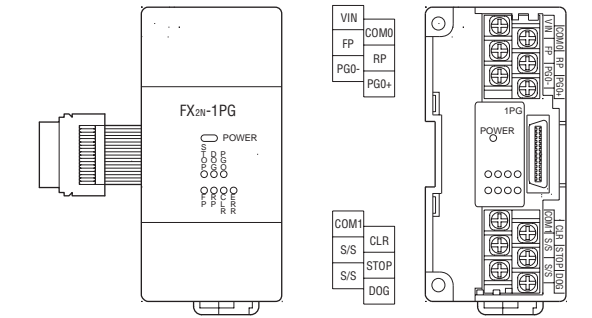
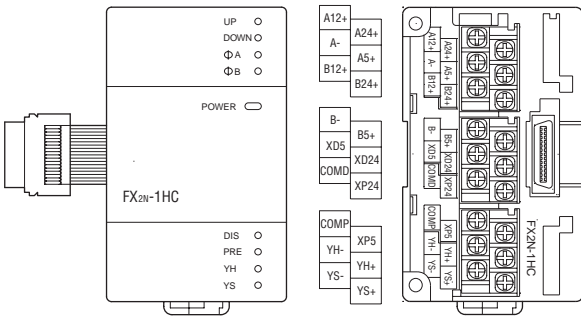
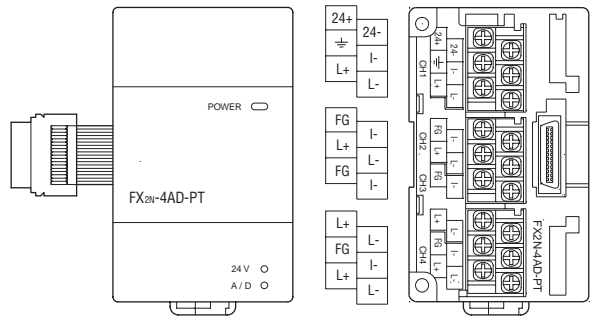
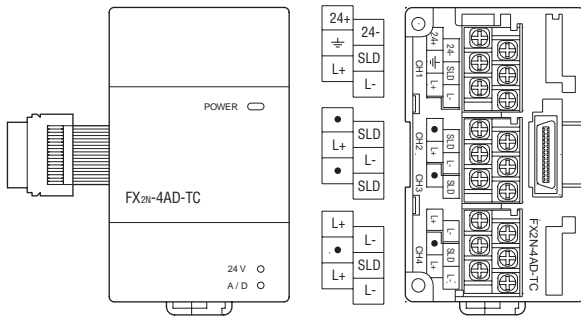
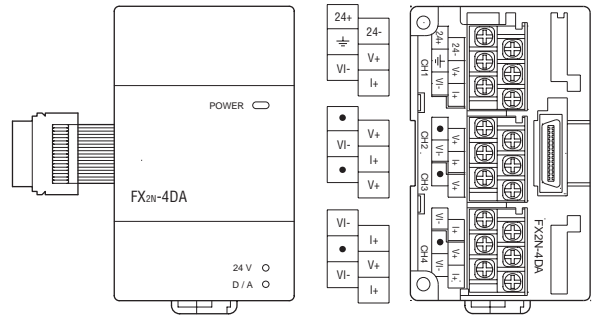
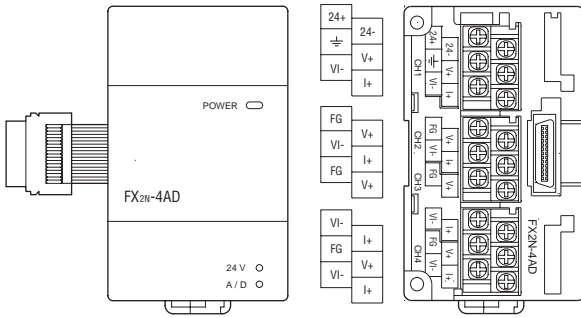

Special Function Modules MELSEC FX

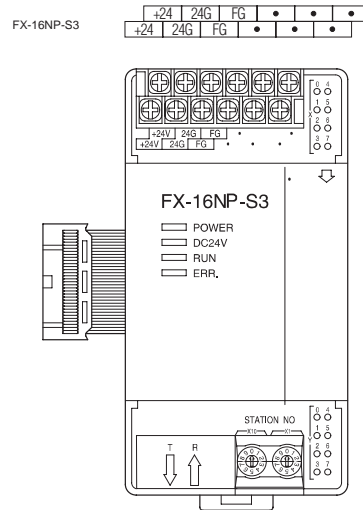
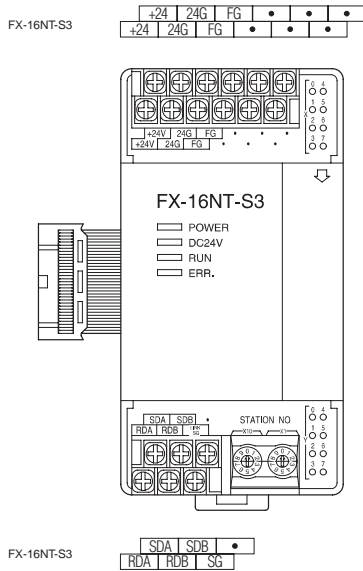
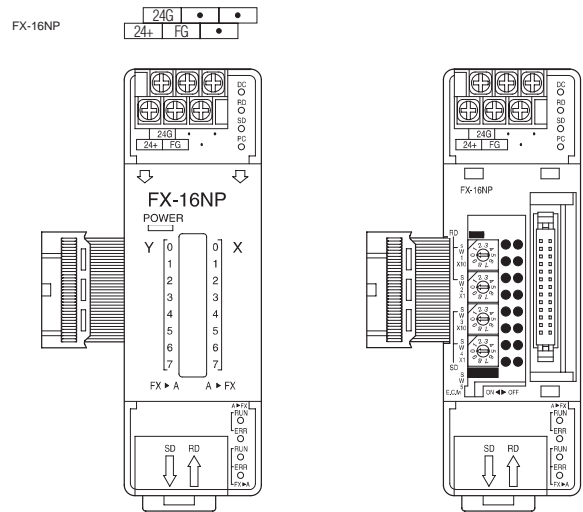
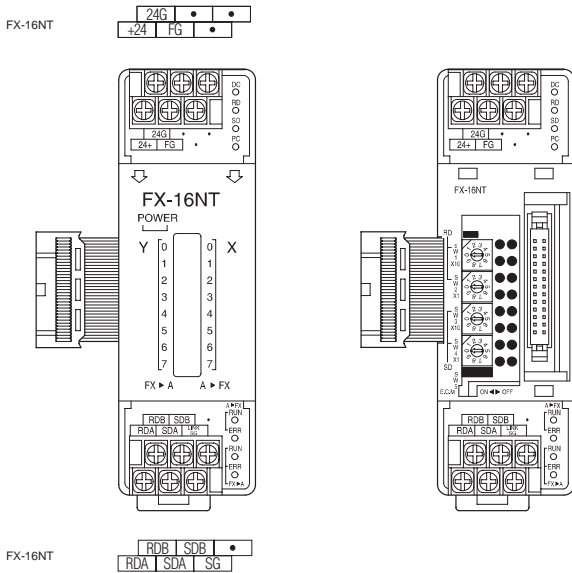

Dimensions of Base Units and Compact Extension Units MELSEC FX0N

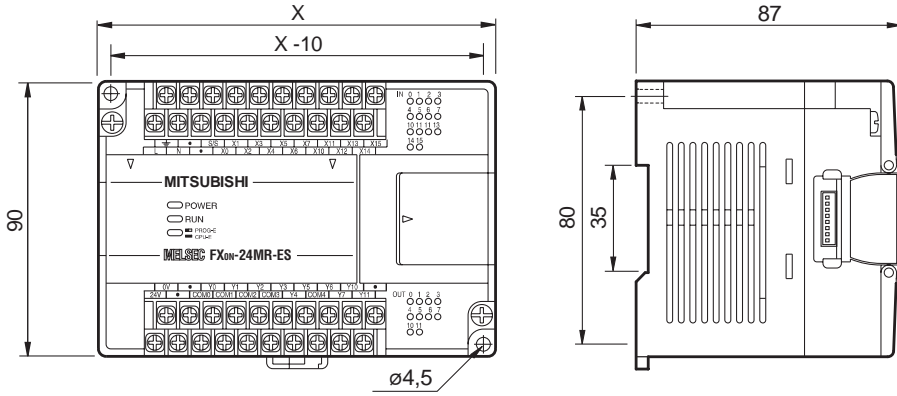

Type	X (in mm)
FX0N-24MR-DS	130
FX0N-24MR-ES/UL	130
FX0N-24MT-DSS	130
FX0N-40MR-DS	150
FX0N-40MR-ES/UL	150
FX0N-40MT-DSS	150
FX0N-60MR-DS	185
FX0N-60MR-ES/UL	185
FX0N-60MT-DSS	185
FX0N-40ER-DS	150
FX0N-40ER-ES/UL	150

Dimensions of Modular Extension Units and Special Function Modules MELSEC FX0N

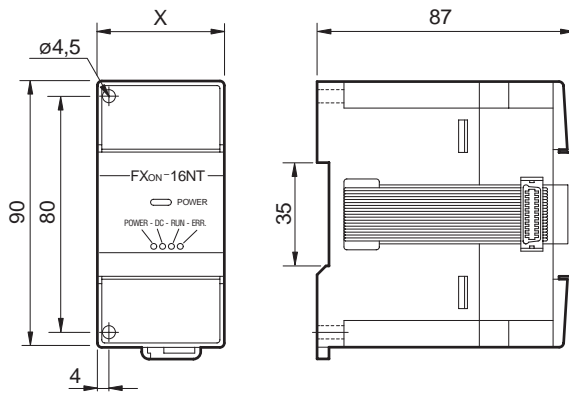

Type	X (in mm)
FX0N-8ER-ES/UL	43
FX0N-8EX-ES/UL	43
FX0N-8EYR-ES/UL	43
FX0N-8EYT-ESS/UL	43
FX0N-16EX-ES/UL	70
FX0N-16EYR-ES/UL	70
FX0N-16EYT-ES/UL	70
FX0N-232ADP	43
FX0N-3A	43
FX0N-16NT	43
FX0N-32NT-DP	43
FX0N-485ADP	43

Dimensions of Base Units MELSEC FX2N

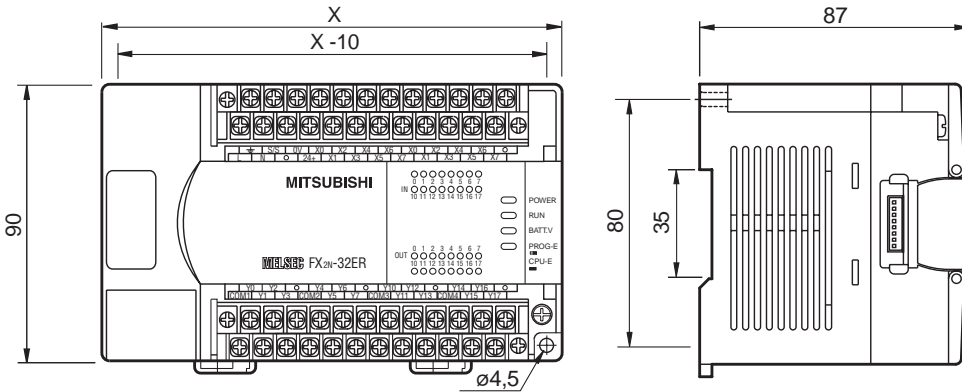

Base Units

Type	X (in mm)
FX2N-16M	130
FX2N-32M	150
FX2N-48M	182
FX2N-64M	220
FX2N-80M	285
FX2N-128M	350

Dimensions of Compact and Modular Extension Units MELSEC FX2N

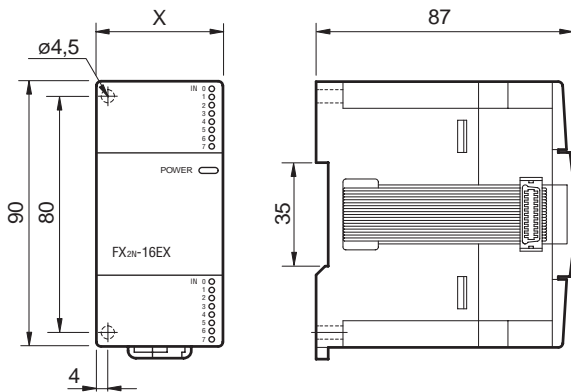

Compact Extension Units

Type	X (in mm)
FX2N-32ER-ES/UL	150
FX2N-32ET-ESS/UL	150
FX2N-48ER-DS	182
FX2N-48ER-ES/UL	182
FX2N-48ET-DSS	182

Modular Extension Units

Type	X (in mm)
FX2N-16EX-ES/UL	40
FX2N-16EYR-ES/UL	40
FX2N-16EYT-ESS/UL	40



Dimensions of Special Function Modules MELSEC FX2N

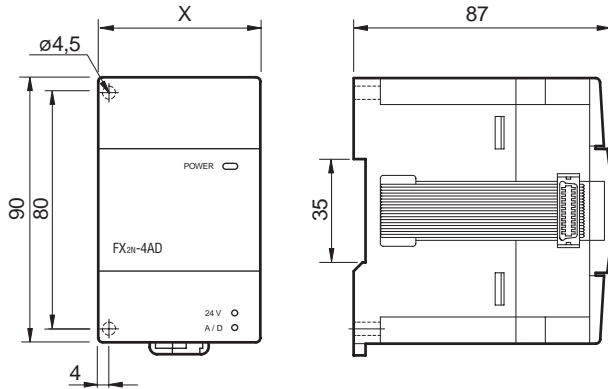

Special Function Modules FX2N

Type	X (in mm)
FX2N-4DA	55
FX2N-4AD	55
FX2N-4AD-TC	55
FX2N-4AD-PT	55
FX2N-1HC	55
FX2N-1PG-E	43
FX2N-232-IF	55

Dimensions of Special Function Modules MELSEC FX

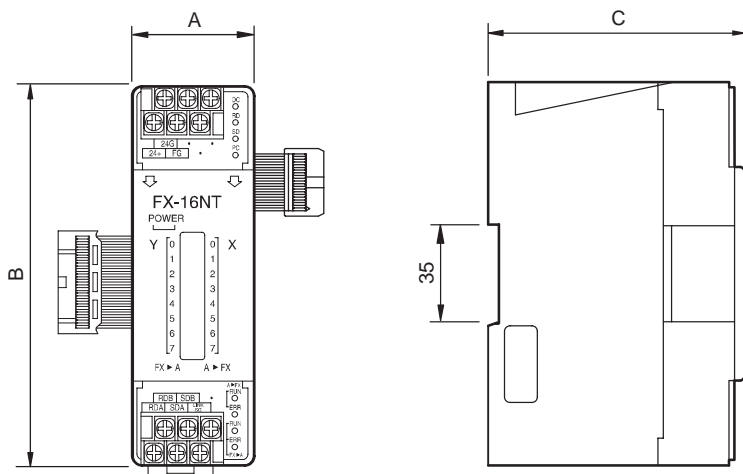

Special Function Modules FX

Type	A x B x C (in mm)
FX-16NP, FX-16NT	45 x 140 x 95
FX-16NP-S3, FX-16NT-S3	73 x 140 x 95



Programming and Documentation Software for Standard Personal Computers

With MELSEC MEDOC, MELSEC MEDOC FX/WIN and MELSEC MEDOC *plus*, MITSUBISHI ELECTRIC offers a programming and documentation system which makes your personal computer into an

efficient programming and documentation system for all controllers of the MELSEC FX series.

To take account of the importance of programming, all program packages permit efficient and time-saving programming.

MELSEC MEDOC



In MELSEC MEDOC, convenient editing functions are accessible through a clearly laid out menu.

The fast, convenient creation and processing of PLC programs are performed by means of either a contact plan or a list of instructions.

In addition to versatile monitor and test functions, MELSEC MEDOC has an extensive Help menu.

By connecting a standard printer, it is possible to produce input/output lists and cross reference lists for documentation.

The software is supplied complete with an SC-09N serial interface cable for connecting the PLC to one of the PC's serial ports.

Software	F-Set E 3,5"	F-Set G 3,5"	FX0-Set E	FX0-Set G
Series	FX, FX0, FX0S, FX0N	FX, FX0, FX0S, FX0N	FX0, FX0S	FX0, FX0S
Language	English	German	English	German
Format	3,5"	3,5"	3,5" / 5,25"	3,5" / 5,25"
Order information	Art. no. 56123	56124	32712	32787

MELSEC MEDOC FX/WIN

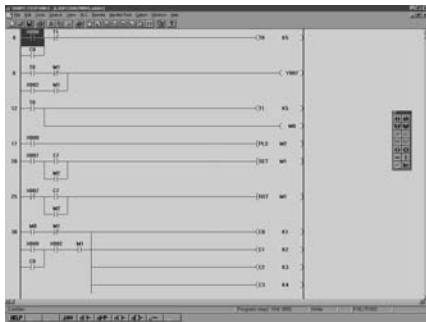

MELSEC MEDOC FX/WIN is the standard programming software for the MELSEC FX family and combines all functions of MELSEC MEDOC with the user guidance of Microsoft Windows®.

MELSEC MEDOC FX/WIN provides the user with facilities for structured programming, function modules and many different diagnostic functions.

This software possesses all Windows®-specific benefits and is especially geared to the new FX2N series.

The software is supplied complete with an SC-09N serial interface cable, which is used for the connection between the PLC and a serial interface of a personal computer.

MELSEC MEDOC *plus* can be run under Windows 3.11 and Windows 95.

Software	MM FX/WIN
Series	Whole FX family
Language	Englisch
Format	3,5" diskettes
Order information	Art. no. 70536

MELSEC MEDOC *plus*

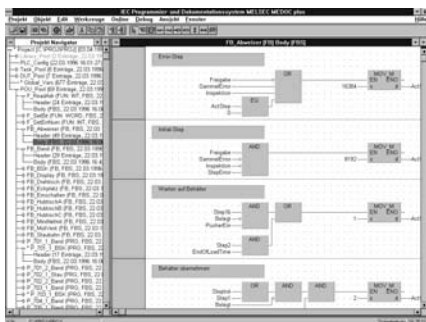

MELSEC MEDOC *plus* provides all functions of the pre-mentioned programs and meets the programming standard for the future: IEC 1131.3. This makes MELSEC MEDOC *plus* ready for the programming standard of the future and offers in addition the basis for the on-leading programming of the MELSEC A and Q series.

MELSEC MEDOC *plus* can be run under Windows 3.11 and Windows 95.

The software is supplied complete with an SC-09N serial interface cable.

Software	F-Set E	F-Set G
Series	Whole FX family	Whole FX family
Language	English	German
Format	3,5" diskettes	3,5" diskettes
Order information	Art. no. 56118	56117

Parameter Software for Profibus Networks and Process Supervision System for all Mitsubishi PLCs



MELSEC ProfiMap



MELSEC ProfiMap V2.0 is a user friendly configurations software for open networks like MAP 3.0/ETHERNET and PROFIBUS/DP or PROFIBUS/FMS.

The software package is a 32 bit application for Windows 95 and Windows NT4.0. Configuration of all PROFIBUS modules for the MELSEC series is possible.

Due to the supported extended user parameters of a GSD file, easy parameter setting of PROFIBUS/DP slave devices is possible even for third party devices.



Software	Full version V2.0	Update V1.0 to V2.0
Supported master modules for the Mitsubishi MELSEC AnS/QnAS and A/Q series	Profibus/DP: A1SJ71PB92D, AJ71PB92D Profibus/FMS: A1SJ71PB96F, AJ71PB96F MAP3.0/Ethernet: AJ71M56EF2	Profibus/DP: A1SJ71PB92D, AJ71PB92D Profibus/FMS: A1SJ71PB96F, AJ71PB96F MAP3.0/Ethernet: AJ71M56EF2
Language	English	English
Configuration cable	ProfiCab is included	ProfiCab is not included
Disk type	3,5" disks	3,5" disks
Order information	Art. no. 102996	102997



MELSEC MX SCADA



MELSEC MX SCADA is a process visualisation system that can handle everything from simple installations to complex production control systems. The software package can administer up to 100000 ob-

jects. A variety of interfaces are supported, including ETHERNET. The software runs under Windows 95 and Windows NT and is available in a variety of different

Software	Development version	Run-time version	DEMO version
Series	All MELSEC PLC	All MELSEC PLC	All MELSEC PLC
Language	Englisch	Englisch	Englisch
Disk type	CD ROM	CD ROM	CD ROM
Order information	Art. no. on request	on request	65135



■ Hand-Held Programming Unit FX-10 P-E and FX-20 P-E

These small hand-held programming units designed for industry have a user-friendly keyboard and a clearly laid out, back-lit LC display. On both programming units, the MELSEC FX family is programmed in the list of instructions. The FX-20P has an integrated CMOS-RAM with capacitor buffering.

This ensures storage of the PLC program and its duplication, for example for series machines.

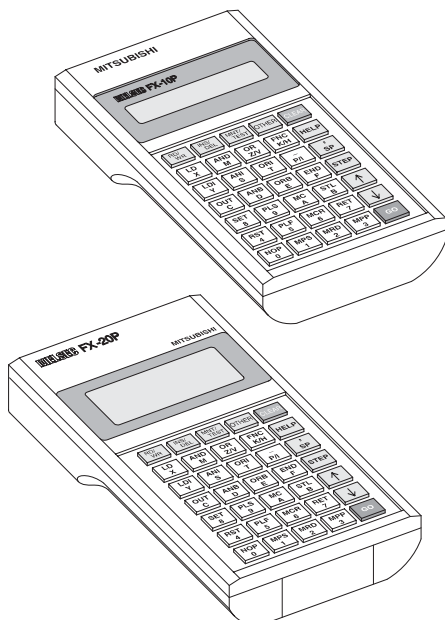

Specifications	FX-10 P-E	FX-20 P-E
General specifications	Conforms to base units FX2N, FX0N, FX0S	
Ambient temperature	0 – 40 °C	0 – 40 °C
Ambient relative humidity (non-condensing)	35 – 85 %	35 – 85 %
Power supply	V DC 5 ± 5 % by PLC	DC 5 ± 5 % by PLC
Current consumption	mA 120	150
Display	LCD	LCD (backlight)
Character display	16 x 2	16 x 4
Connectable PLC	FX0, FX0S, FX, FX0N, FX2N*	FX0, FX0S, FX, FX0N, FX2N*
Key board	keys 35	35
Memory	—	8000 steps PLC-program
Data security	—	Data is safed up to 3 days by capacitor.
Cable, is adjoint	—	FX-20P-CAB
Weight	kg 0.25	0.4
Dimensions (W x H x D)	mm 85x160x27	90 x 170 x 30
Order information	Art. no. 32538	23802

*Version 3.0 or higher

■ Connection Cable and Adapter Cable

With the adapter cable FX-20P-CADP, the peripheral units of the FX series are connected to units of the FX0, FX0S and FX0N series.

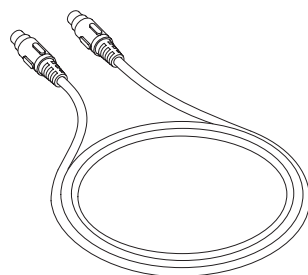

Data	FX-20P-CAB	FX-20P-CAB0	FX-20P-CABP
Cable	type Connection cable	Connection cable	Adapter cable
Length	cm 150	300	20
For connecting to controller	FX	FX0S, FX2N, FX0N	FX0S, FX2N, FX0N
Order information	Art. no. 30815	55917	31870

■ EPROM Writer FX-20 P-RWM

The EPROM writer FX-20 P-RWM is plugged directly into the hand-held programming unit FX-20 P-E. It is used for transferring the PLC programs of the MELSEC FX controller to the EPROM memory cassette FX-EPROM-8. Conversely, existing programs can be read

from the FX-EPROM-8 memory cassette into the CMOS-RAM of the controller and program comparisons carried out.

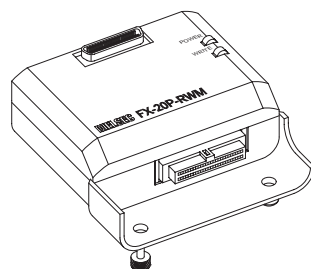

Data	FX-20 P-RWM
Order information	Art. no. 23818

■ ProfiCon Profibus Connector

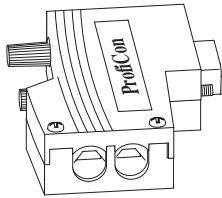

The ProfiCon bus connector plug is designed for connecting DIN 19245 standard Profibus components with data transfer rates of up to 12 Mbaud.

The connector is available with or without a selectable termination resistor.

Specifications	ProfiCon	ProfiConT
Data rate 12 Mbit/s	supported	supported
Terminator	No	Yes (selectable)
Order information	Art. no. 64127	87035



Adapter cable	72	FX0N-40B	54	General specifications	
Base units		FX0N-40ER-DS	32	FX0S series	12
FX0S series	12	FX0N-40ER-ES/UL	32	FX0N/FX2N series	25
FX0N series	26	FX0N-40ET-DSS	32	Input-SIM: FX0S/FX0N	14
FX2N series	28	FX0N-40MR-DS	26	Input-SIM: FX2N	53
Battery	54	FX0N-40MR-ES/UL	26	Interface converter	52
Combination possibilities	21	FX0N-40MT-DSS	26	MELSEC MEDOC	70
Compact extension units	32	FX0N-60MR-DS	27	MELSEC MEDOC <i>plus</i>	70
Connection cable	55, 72	FX0N-60MR-ES/UL	27	MELSEC MEDOC <i>plus</i> tutorial	70
Configuration FX0N/FX2N series	24	FX0N-60MT-DSS	27	MELSECNET/MINI	42
CR01-R2/R4 SET	52	FX0N-232ADP	40	Memory cassettes	52
CR01-R4/R4	52	FX0S-10MR-DS	12	Model designation code	11
Description of units		FX0S-10MR-ES/UL	12	Modular extension units	34
FX0S series	11	FX0S-10MT-DSS	12	MX SCADA software	71
FX0N/FX2N series	20	FX0S-14MR-DS	12	Networks (overview)	8
Dimensions		FX0S-14MR-ES/UL	12	1:n multidrop	45
FX0S series	17	FX0S-14MT-DSS	12	MELSECNET/MINI	42
FX0N series	66	FX0S-20MR-DS	13	Parallel link	45
FX2N series	67	FX0S-20MR-ES/UL	13	Peer-to-peer	45
Digital I/Os	31	FX0S-30MR-DS	13	PROFIBUS/DP	48
EPROM writer	72	FX0S-30MR-ES/UL	13	Power consumption	23
EPROM/EEPROM cassettes	52	FX0S-30MT-DSS	13	Profibus plug	73
Extension units		FX2N-1HC	39	ProfiMap software	71
compact	32	FX2N-1PG-E	39	Programming units	72
modular	34	FX2N-4AD	37	Programm loader	15
F2-40BL	54	FX2N-4AD-PT	38	PROM adapter	53
FX-10 P-E	72	FX2N-4AD-TC	38	Real-time clock cassette	52
FX-16NP	44	FX2N-4DA	37	Simulation box	14, 53
FX-16NP-S3	44	FX2N-8AV-BD	36	Simulation strip	14, 53
FX-16NT	44	FX2N-16EX-ES/UL	35	Special function modules	
FX-16NT-S3	44	FX2N-16EYR-ES/UL	35	analog modules	36
FX-20 P-CAB	72	FX2N-16EYT-ES/UL	35	common description	22
FX-20 P-CAB0	72	FX2N-16MR-ES/UL	28	communications modules	43, 46, 50
FX-20 P-CABP	72	FX2N-16MT-ESS/UL	28	PROFIBUS modules	49
FX-20 P-E	72	FX2N-32ER-ES/UL	33	interface modules	40, 46
FX-20 P-RWM	72	FX2N-32ET-ESS/UL	33	counter/positioning modules	39
FX-65EC	55	FX2N-32MR-DS	28	System description	
FX-485PC-IF	47	FX2N-32MR-ES/UL	28	general	4
FX-EPROM-8	52	FX2N-32MT-DSS	28	FX0S series	10
FX-EEPROM-4	52	FX2N-32MT-ESS/UL	28	FX0N series	18
FX-EEPROM-4C	52	FX2N-48ER-DS	33	FX2N series	19
FX-EEPROM-8	52	FX2N-48ER-ES/UL	33	System specifications	
FX-RAM-8	52	FX2N-48ET-DSS	33	FX0S series	13
FX-RAM-8C	52	FX2N-48ET-ESS/UL	33	FX0N/FX2N series	25
FX-ROM SOC1	53	FX2N-48MR-DS	29	Terminal assignment	
FX-RTC	52	FX2N-48MR-ES/UL	29	FX0S series	16
FX0-10LDR	15	FX2N-48MT-ESS/UL	29	FX0N extension units	60
FX0N-3A	36	FX2N-48MT-DSS	29	FX2N extension units	61
FX0N-8ER-ES/UL	34	FX2N-64MR-DS	29	FX0N base units	56
FX0N-8EX-ES/UL	34	FX2N-64MR-ES/UL	29	FX2N base units	57
FX0N-8EYR-ES/UL	34	FX2N-64MT-DSS	29	Special function modules	63
FX0N-8EYT-ESS/UL	34	FX2N-64MT-ESS/UL	29	FX0S series	12
FX0N-16EX-ES/UL	34	FX2N-80MR-DS	30	FX0N series	25
FX0N-16EYR-ES/UL	34	FX2N-80MR-ES/UL	30	Input-SIM: FX0S/FX0N	14
FX0N-16EYT-ESS/UL	34	FX2N-80MT-ESS/UL	30	Input-SIM: FX2N	53
FX0N-16NT	43	FX2N-80MT-DSS	30	Interface converter	52
FX0N-24MR-DS	26	FX2N-128MR-ES/UL	30	MELSEC MEDOC	70
FX0N-24MR-ES/UL	26	FX2N-128MT-ESS/UL	30	MELSEC MEDOC <i>plus</i>	70
FX0N-24MT-DSS	26	FX2N-232BD	41	MELSEC MEDOC <i>plus</i> tutorial	70
FX0N-32NT-DP	49	FX2N-232IF	40	MELSECNET/MINI	42
		FX2N-422BD	41	Memory cassettes	52
		FX2N-485ADP	46	Model designation code	11
		FX2N-485BD	46	Modular extension units	34
		FX2N-CNV-BD	50	MX SCADA software	71
		FX2N-CNV-IF	50	Networks (overview)	8
		FX2N-EEPROM-16	52	1:n multidrop	45
				MELSECNET/MINI	42
				Parallel link	45
				Peer-to-peer	45
				PROFIBUS/DP	48
				Power consumption	23
				Profibus plug	73
				ProfiMap software	71
				Programming units	72
				Programm loader	15
				PROM adapter	53
				Real-time clock cassette	52
				Simulation box	14, 53
				Simulation strip	14, 53
				Special function modules	
				analog modules	36
				common description	22
				communications modules	43, 46, 50
				PROFIBUS modules	49
				interface modules	40, 46
				counter/positioning modules	39
				System description	
				general	4
				FX0S series	10
				FX0N series	18
				FX2N series	19
				System specifications	
				FX0S series	13
				FX0N/FX2N series	25
				Terminal assignment	
				FX0S series	16
				FX0N extension units	60
				FX2N extension units	61
				FX0N base units	56
				FX2N base units	57
				Special function modules	63

FA CENTER

MITSUBISHI ELECTRIC CORPORATION JAPAN
 Mitsubishi Denki Bldg.
 Marunouchi
Tokyo 100
JAPAN
 Phone: (03) 3218-3176
 Fax: (03) 3218-2422

MITSUBISHI ELECTRIC EUROPE B.V. EUROPE
 Factory Automation
 Gothaer Straße 8
D-40880 Ratingen
Germany
 Phone: (0 21 02) 486-0
 Fax: (0 21 02) 4 86-1 12

MITSUBISHI ELECTRIC EUROPE EUROPE B.V. UK
 Industrial Division
 Travellers Lane
GB-Hatfield Herts. AL10 8 XB
Great Britain
 Phone: (0 17 07) 27 61 00
 Fax: (0 17 07) 27 86 95

MITSUBISHI ELECTRONICS AMERICA, INC. USA
 Industrial Automation Division
 800 Biermann Court
Mt. Prospect, IL 60056
United States of America
 Phone: (708) 298-9223
 Fax: (708) 298-1834

Ryoden (Holdings) Ltd. HONG KONG
 10th Fl., Manulife T.,
 169 Electric Rd., N. Point
Hong Kong
 Phone: 2887-8870
 Fax: 2578-2461

P.T. SAHABAT INDONESIA INDONESIA
 Blok A/Utara No. 1 Kav, No. 11
Jakarta 11050
Indonesia
 Phone: 6610651
 Fax: 6603700

SETSUYO ENTERPRISE Co.,Ltd. TAIWAN
 TAIWAN
 3rd Fl., No.122, Wu Kung 2nd Road
Wu-Ku Hsiang Taipei Hsien
Taiwan
 Phone: (02) 298 - 17 95
 Fax: (02) 298 - 18 25

MITSUBISHI ELECTRIC SALE SINGAPORE SINGAPORE Pte. Ltd. SINGAPORE
 Industrial Engineering Center
 No. 6, Commonwealth Lane #01 - 01
149547 Singapore
 Phone: 476 - 72 35
 Fax: 476 - 74 39

EUROPEAN REPRESENTATIVES

GEVA GmbH AUSTRIA
 Wiener Straße 89
A-2500 Baden
 Phone: (0 22 52) 8 55 52-0
 Fax: (0 22 52) 4 88 60

GETRONICS NV/SA BELGIUM
 Pontbeeklaan 43
B-1731 Zellik
 Phone: (02) 4 67 17 51
 Fax: (02) 4 67 17 45

INEA CR d.o.o. CROATIA
 Drvinje bb
HR-10000 Zagreb
 Phone: (01) 36 71 40
 Fax: (01) 36 71 40

AUTOCONT s.r.o. CZECHIA
 Nemocnici 12
CZ-70100 Ostrava 1
 Phone: (0 69) 6 15 21 11
 Fax: (0 69) 6 11 35 62

ELPEFA A/S DENMARK
 Geminivej 32
DK-2670 Greve
 Phone: (0 43) 95 95 95
 Fax: (0 43) 95 95 90

MITSUBISHI ELECTRIC EUROPE B.V. - UK Branch ENGLAND
 Travellers Lane
GB-Hatfield Herts. AL10 8 XB
 Phone: (0 17 07) 27 61 00
 Fax: (0 17 07) 27 86 95

UTU ELEKTROTEHNIKA ESTONIA
 Laki 12 E
EE-0006 Tallinn
 Phone: (06) 563 194
 Fax: (06) 563 836

Beijer Electronics OY FINLAND
 Elannontie 5
FIN-01510 Vantaa
 Phone: (09) 615 20 11
 Fax: (09) 615 20 500

IP Systèmes FRANCE
 8, Rue Colonel Chambonnet
F-69672 Lyon Bron
 Phone: (04) 72 14 18 00
 Fax: (04) 72 14 18 01

MITSUBISHI ELECTRIC EUROPE B.V. - German Branch GERMANY
 Gothaer Straße 8
D-40880 Ratingen
 Phone: (0 21 02) 486-0
 Fax: (0 21 02) 4 86-1 12

GEVA Kft HUNGARY
 Tamási Áron u. 34
H-1124 Budapest
 Phone: (01) 3 75 38 98
 Fax: (01) 3 75 06 88

EUROPEAN REPRESENTATIVES

MITSUBISHI ELECTRIC EUROPE B.V. - Irish Branch IRELAND
 Westgate Business Park
IRL-Dublin 22
 Phone: (1) 450 50 07
 Fax: (1) 456 13 37

CARPANETO & C. S.p.A. ITALY
 Via Ferrero 10
I-10090 Cascine Vica-Rivoli (TO)
 Phone: (0 11) 95 90 111
 Fax: (0 11) 95 90 250

Geveke Electronics bv NETHERLANDS
 Donauweg 10
NL-1043 AJ-Amsterdam
 Phone: (0 20) 5 86 15 92
 Fax: (0 20) 5 86 19 27

Beijer Electronics A/S NORWAY
 Teglverksveien 1
N-3002 Drammen
 Phone: (32) 24 30 00
 Fax: (32) 84 85 77

MPL Technology SP. Z.o.o POLAND
 ul. Wroclawska 53
PL-30011 Kraków
 Phone: (0 12) 632 28 85
 Fax: (0 12) 632 47 82

F. Fonseca Lda PORTUGAL
 Estrada de Taboeira 87/89, Esgueira
P-3800 Aveiro
 Phone: (0 34) 31 58 00
 Fax: (0 34) 31 58 04

TUINGDOR ROMANIA
 20, Fierarilor Street
RO-72126 Bucuresti
 Phone: (01) 211 98 01
 Fax: (01) 210 71 81

INEA d.o.o. SLOVENIA
 Ljubljanska 80
SI-61230 Domžale
 Phone: (0 61) 71 80 00
 Fax: (0 61) 72 16 72

Medición y Control, S.A. SPAIN
 Gr. Via d. l. Corts Catalanes 133, 4
E-08014 Barcelona
 Phone: (03) 4 22 77 00
 Fax: (03) 4 32 28 47

Beijer Electronics AB SWEDEN
 Box 325
S-20123 Malmö
 Phone: (0 40) 35 86 00
 Fax: (0 40) 93 23 01

ECONOTEC AG SWITZERLAND
 Postfach 282
CH-8309 Nürensdorf
 Phone: (01) 838 48 11
 Fax: (01) 838 48 12

EUROPEAN REPRESENTATIVES

GTS TURKEY
 Fahri Gizden Sokak,
 Hacaloglu Apt. No. 22/6
TR-80280 Gayrettepe/Istanbul
 Phone: (2 12) 267 40 11
 Fax: (2 12) 266 14 50

MIDDLE EAST REPRESENTATIVE

TEXEL Electronics Ltd. ISRAEL
 P.O. Box 6272
IL-Netanya 42160
 Phone: (09) 863 08 91
 Fax: (09) 885 24 30