

Top View of Assembly

SECTION A-A
End View of Assembly

Series 1590N1 (Flanged Lid)

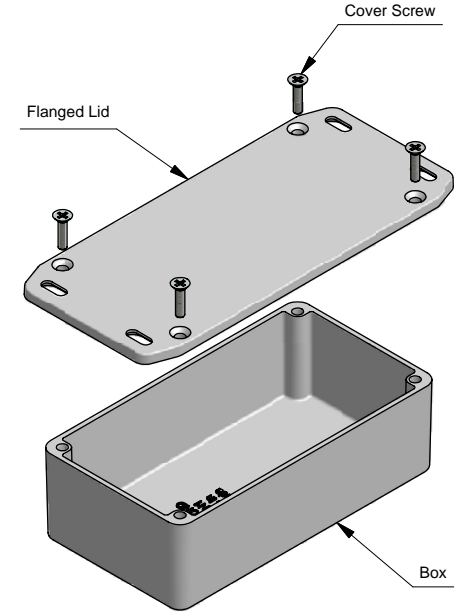
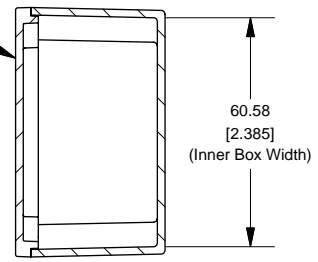
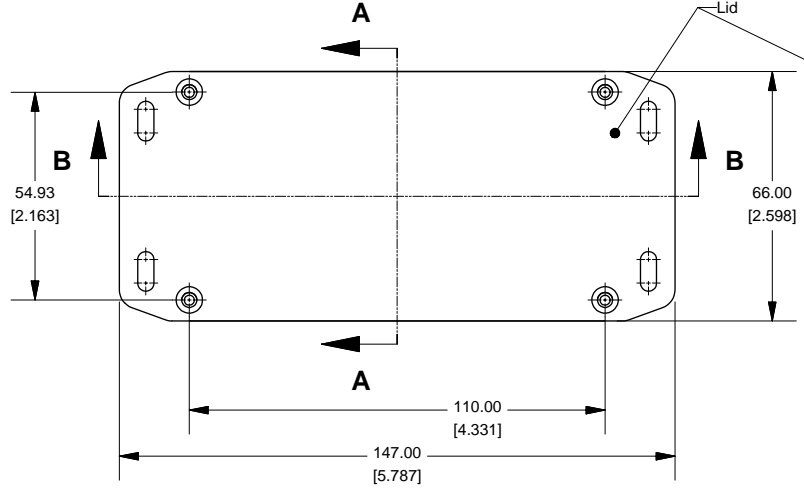

SECTION B-B
Side View of Assembly

Top View Looking Inside Box

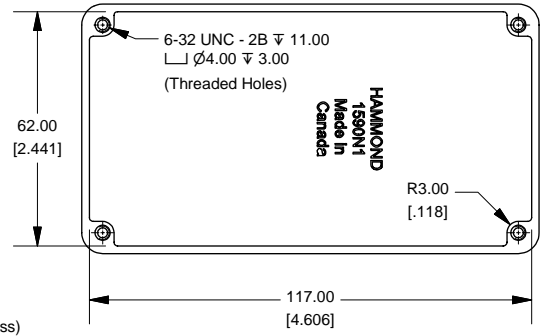
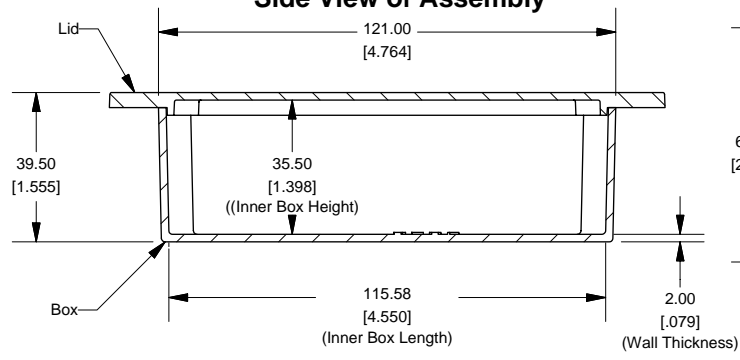

NOTE
Purchased assembly includes box, lid and 4 cover screws.
Box and lid are made from Diecast Aluminum Alloy (alloy type 360.1).

PART NUMBERS	
1590N1FL Enclosure	
Unfinished	1590N1FL
Black Textured Powder Paint	1590N1FLBK
1590N1FL Liquid Resistant Powder Enclosure (Silicon Factory Installed Gasket)	
Unfinished	1590WN1FL
Black Textured Powder Paint	1590WN1FLBK
ACCESSORIES	
Unfinished	
Cover Screws (Pkg 100)	
[6-32 x 1/2" Nickel Plated Screws]	1590MS100
Black Textured Powder Paint	
Cover Screws (Pkg 50)	
[6-32 x 1/2" Stainless Steel Black Screws]	1590MS50BK

Lid

SECTION C-C
Side of Slot

