

### Top View of Assembly

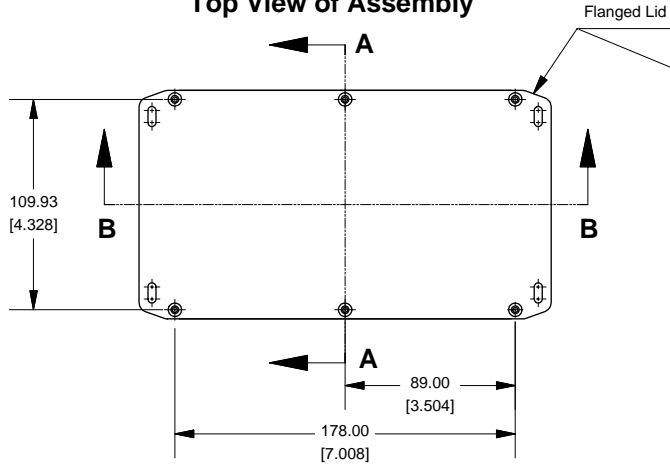

### SECTION A-A End View of Assembly

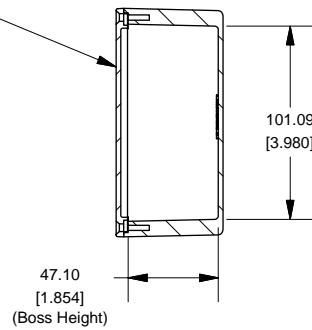

## Series 1590DFL (Flanged Lid)

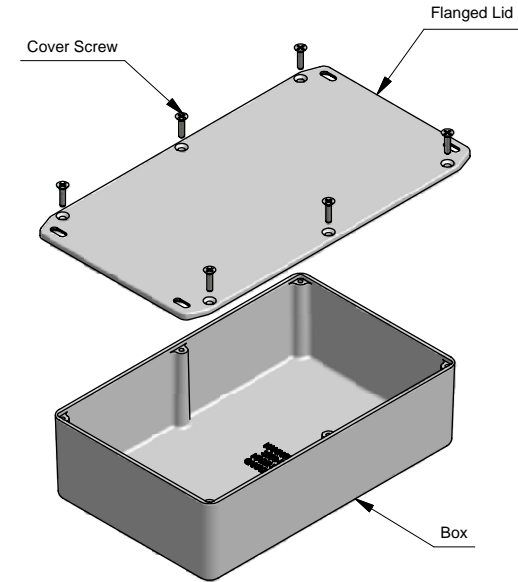

### SECTION B-B Side View of Assembly

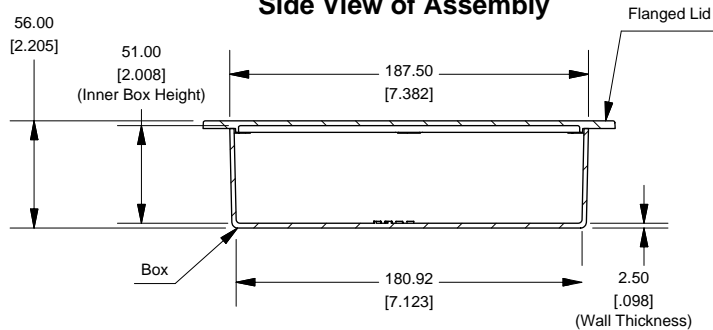

### Top View Looking Inside Box

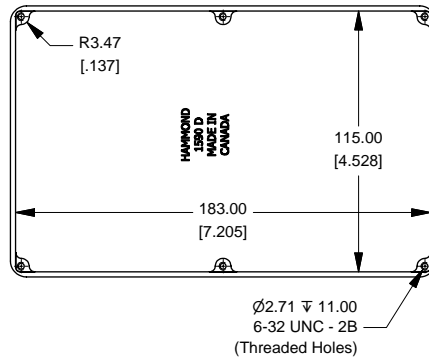

#### NOTE

Purchased assembly includes box, lid and 6 cover screws.  
Box and lid are made from Diecast Aluminum Alloy (alloy type 360.1).

#### PART NUMBERS

1590DFL Enclosure	
Unfinished	1590DFL
Black Textured Powder Paint	1590DFLBK
1590DFL Liquid Resistant Enclosure (Silicon Factory Installed Gasket)	
Unfinished	1590WDFL
Black Textured Powder Paint	1590WDFLBK
ACCESSORIES	
Unfinished	
Cover Screws (Pkg 100)	
[6-32 x 1/2" Nickel Plated Screws]	1590MS100
Black Textured Powder Paint	
Cover Screws (Pkg 50)	
[6-32 x 1/2" Stainless Steel Black Screws]	1590MS50BK

### Lid

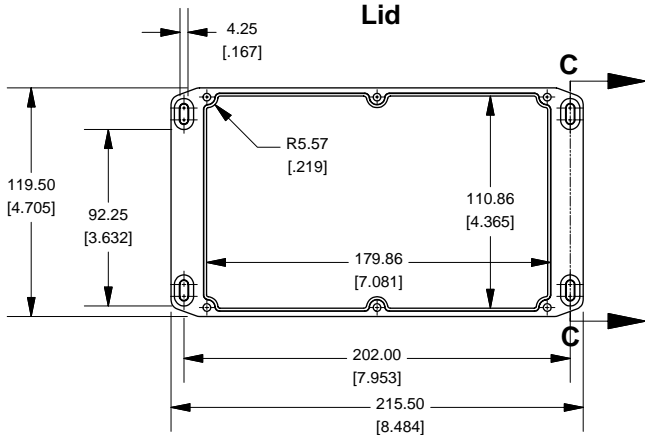

### SECTION C-C Side View of Slot

